

BRENT

**82-SERIES
GRAIN CARTS**



1282·1082·882·782

When you're ready **for the best**

YOUR HARVEST DATA COLLECTION SOLUTIONS



Complete touch-screen operation



Harvest reports with a single click from any location



UHarvest® data management offers ISObus terminal or tablet operation while automatically storing detailed information about each load:

- Track by grower, farm, field, destination, trucks and variety for precision recordkeeping
- Accu-Save feature automatically records every load without operator involvement
- Multiple-user access for real-time viewing and control
- Slingshot account for comprehensive and simple harvest reporting (no annual fee)
- Go to uharvest.net for complete information

SCALE SYSTEMS

MODEL 410

The 410 is specifically designed to accumulate weights within a field and its patent-pending START/STOP button makes it easy for anyone to use.

MODEL 520

The 520 features automatic accumulation of weights per field entry for ease of use. The alpha-numeric keyboard for easily editing field information also features a large 26-character display. This option also includes the ability to download field information via USB from your computer to the scale monitor and then back to the computer.

Visit brentequip.com for detailed information on all scale offerings.



410 scale



520 scale

BRENT

82-SERIES
GRAIN CARTS



1282•1082•882•782

When you're ready **for the best**

When you're ready
for the best, you're
ready for a Brent.



Harvest goes smoother with every Brent grain cart. The corner-auger positioning provides the industry's greatest unloading height and reach. Add in the 82 series twisting, turret-style downspout with 60° rotation for precisely controlling grain flow, and you'll push harvest efficiency to the max, with unloading speeds up to 625 bushels per minute.

With capacities ranging from 1,200 bushels to 750 bushels, there is a size available for every operation.



60° rotating downspout for precise unloading control



BRENT

AUGERS

Brent 82 series grain carts feature corner-auger positioning for the greatest unloading height and reach. It's easy to reach across ditches and fences to fill the corners and top off each load, even over the tallest trucks and wagons.



BRENT

- The patented self-aligning, rubber-cushioned Soft-Start auger mechanism ensures smooth and complete engagement of the upper and lower augers at start-up for reduced stress and longer driveline life.
- The auger's corner positioning means 100% visibility from the tractor seat.
- The model 1282's turbo-charged unloading auger features a fully recessed 22"-diameter lower auger that feeds a 20"-diameter upper auger for unloading speeds up to 625 bushels per minute.
- Electronic balancing of the upper and lower augers, along with the lower hanger bearing and upper auger bushing, virtually eliminates vibration for extended auger life.
- Upper and lower high-volume 20"-diameter augers on models 1082 and 882 deliver unloading speeds up to 500 bushels per minute.
- The 18"-diameter auger on the model 782 moves grain at up to 450 bushels per minute.
- Utilization of the newest hydraulic-system technology allows the auger to fold and unfold at industry-leading speed.
- When extended, a lock-valve secures the auger in position with a positive seal for a leak-free joint.
- The auger tucks compactly under the side of the cart for ease of transport and storage.
- Exclusive extended-wear flighting provides .375" thickness at the outer edge of the entire flighting for longer life.
- The lower auger is housed in a deep sump and constructed with "leaned" double flighting for greater grain-carrying capacity and complete cleanout.



Soft-start auger mechanism



22-20 turbo-charged unloading auger



Standard 60° turret-style downspout for maximum unloading control.



CHASSIS

In addition to having the widest variety of undercarriage options, the Brent chassis design ensures smooth performance and stable towing whether traveling down the road or over the roughest field terrain.



Available with cleated rubber tracks with hydraulic tensioning



Width-adjustable tubular steel axle (optional)



Adjustable tongue weight (Models 1082-782)



- The graphite-coated interior and fully recessed auger sump intake ensures fast and complete unloading.
- Two-position axle on models 1082-782 to match load weight to your needs. The rearward setting enhances in-field control; the forward setting lightens the tongue load.
- An optional width-adjustable axle is available to match tire-width patterns to your cropping practices.
- The axle's two-position height adjustability means the cart stays level and tongue weight is optimized while accommodating a variety of tractor and cart wheel and tire sizes.
- A wide variety of undercarriage options are available — high-flotation singles, duals and tracks.
- Track size for the 1282 is 36" x 148"; and 36" x 128" for model 1082.
 - Optional automatic greasing system applies a smaller amount of grease more frequently for ideal undercarriage lubrication.
- The durable primer undercoat, oven-baked enamel topcoat of tractor red or green and silicone-sealed seams resist corrosion for a long-lasting like-new look.
- The exclusive Brent manufacturing process features sleek, waveless sides for added strength.
- Field-proven 4½" bolt-on spindles with 50-ton ratings are manufactured with special-alloy, high-tensile strength steel.
- 10-bolt hubs feature gusseted reinforcement for longer life and maximum carrying capacity.
- The heavy-wall tubular steel main frame and axle, 12-gauge-steel shell and 8-gauge-steel underframe carry the heaviest loads with ease.
- Cast 2" single-tang hitch with smooth chamfer opening allows the cart to follow the terrain for smooth trailing. Bushings to match other appropriate hitch pin sizes are included.



Cast single-tang hitch

Grain Cart — Loaded Ground Pressure P.S.I. (bar)

Undercarriage	1282	1082	882	782
Tracks	11.25	10.94	—	—
480/80x46 Duals	—	17.62	—	—
420/80x46 Duals	—	—	18.32	15.89
380/90x46 Duals	—	24.73	—	—
520/85x42 Duals	18.00	15.31	13.09	11.35
480/80x42 Duals	—	—	15.70	13.62
520/85x38 Duals	18.78	—	—	—
20.8x38	—	—	—	24.44
76/50.00x32	17.00	15.24	—	—
1050/50.00x32	—	16.80	—	—
35.5x32	—	18.27	15.70	13.61
900/60x32	—	24.89	21.28	18.44
30.5x32	—	—	23.41	20.30
24.5x32	—	—	28.19	24.44
1250/50x32	—	15.24	—	—

POWER TRAIN

Brent grain carts outlast and outperform any other grain cart you can own. Durable steel construction, truss frame design and oversized, heavy duty power-train components mean years of dependable and low-maintenance service.



Shearbolt or friction clutch-protected PTO



Exclusive 45° gearbox



Optional multi-port hydraulic drives





- The 45° gearbox with 1¼"-diameter full-length output shaft deliver industry-leading unloading speeds, even with heavy, high-moisture corn.
- Gear tooth length of 1½" in an oil bath for smoothest gear operation and enhanced durability.
- Industry-best load ratings of 3,000 lbs. and 4,000 lbs. for the input shaft bearings, and 4,000 lbs. and 6,000 lbs. for the output shaft bearings.
- The reinforced cast-aluminum gearbox housing and forged steel gears are static rated at 330 h.p. and dynamic rated at 153 h.p. for dependable performance and durability.
- Choice of low-maintenance, quick-couple 1,000 rpm PTO with either shearbolt or friction clutch protection. A PTO with cut-out clutch is standard on the model 1282.
- Optional tongue-mounted, multi-port hydraulic drive with high visibility pressure gauge for ensuring peak performance.
- Hydraulic drive options available to match your tractor's hydraulic output — 105 gpm or 55 gpm for unloading up to 300 bushels per minute and a 30 gpm unit for up to 150 bushels per minute unloading.

BRENT

CONVENIENCE

By any measure, Brent grain carts deliver optimum value. Our 35-year plus history is rich with design innovations that make your harvest — from start to finish — as smooth and stress-free as possible.



High-visibility auger position indicator



Lockable, wheel-operated cleanout door



Color-coded hydraulic hoses





- A high-visibility auger-position indicator shows the exact location of the auger as it folds and unfolds.
- Hydraulically-operated 36" flow gate with easy to see position indicator for controlling grain flow.
- A full 360° sump provides efficient unloading of the entire contents.
- The wheel-operated cleanout door can be locked open for easy and complete cleanout.
- Nighttime unloading visibility is enhanced with two high-intensity halogen lights on the auger and one inside the cart that turn on automatically with the tractor's lights.
- The hydraulic hose storage holder and color-coded, labeled hydraulic hoses mean more convenient hookup and extended hose life.
- The electrical socket storage holder keeps connectors clean and free from corrosion.
- The easy-to-operate side-wind jack makes for convenient hitching and unhitching.
- D.O.T.-approved LED red and flashing amber taillights and reflective striping are highly visible to oncoming traffic.
- Available weatherproof camera package with 7" color monitor allows easy monitoring of loading and unloading. Add a second camera to the rear for a better view of traffic during transport.
- Weatherguard rollover tarps with arched end-caps provide added protection for your harvested crop. Standard on model 1282 and optional on other models.



Cab-mounted color monitor



Weatherguard self-locking tarp

BRENT



82-Series Grain Cart Specifications

Model	1282 w/tracks 36" x 148"	1282	1082 w/tracks 36" x 128"	1082	882	782
Capacity (bushels*)	1,200		1,000+		850	750
Auger Size	22"-20" Turbo		20"		20"	18"
Unloading Speed (bu/min)	625		500		500	450
Hitch Type	Single		Single (clevis avail.)		Single (clevis avail.)	Single (clevis avail.)
Approx. Empty Weight (lbs.)	22,850	20,500	18,820	12,280	11,480	8,740
Approx. Tongue Weight, Loaded (lbs.)	5,000		6,550/4,710		5,750/ 4,160	4,990/ 3,510
Minimum Tractor H.P. Requirements	200+		200+		180+	150+
A	18'		17'1"/16'7"		17'1"/16'7"	14'7"/14'1"
B	6'4"		2'2"		2'2"	3'4"
C	24'11"		21'6"		21'6"	16'5"
D	31'2"		29'5"		29'5"	26'1"
E	13'4"		14'9"		14'8"	14'1"
F	8'8"		10'		10'	10'
G	12'5"		12'7"		11'8"	12'1"
H	11'9"		11'7"		10'10"	10'5"
I	1'1"		1'6"		1'5"	1'5"
J	9'9"	5'9"11" singles	10'6"	11'4"	10'	10'
K	12'9"	-/14'1" singles	13'6"	14'4"	12'6"	12'6"
with 76/50x32 tires	—	14'2"	—	16'6"	—	—
L	11'10"		13'5"		13'5"	12'
M	11'10"		11'10"		11'10"	11'10"
N	—	10'	—	15'	15'	15'
O	—	11'10"	—	16'6"	16'6"	16'6"

*Bushel capacities were measured with #2 corn at 15% moisture (56 lb. test weight)

**When you're ready for the best,
see your nearest Brent products
dealer today, check our website
at brentequip.com or call
1-800-322-6301.**

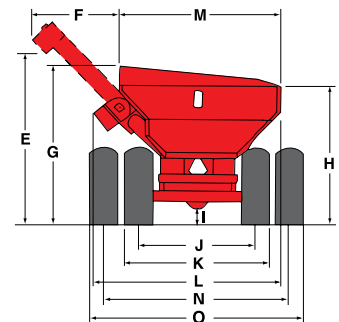
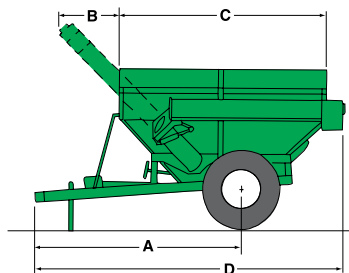

Due to continuing improvements in the design and manufacture of Unverferth products, all specifications contained herein are subject to change without notice.

Unverferth
Manufacturing Company, Inc.

P.O. Box 357 • Kalida, Ohio 45853 • (419) 532-3121

1.800.322.6301



Please remind all family members to use caution and follow recommended safety practices when around all farm equipment. Unverferth Mfg. Co., Inc. supports the efforts of Farm Safety 4 Just Kids.

