

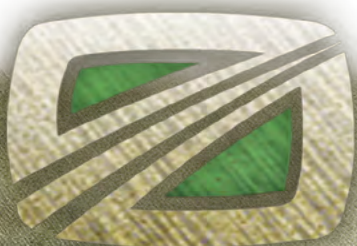

**8385**

**Parallel Linkage Bedder  
Operators Manual**

**Part #125-025-01**



The Orthman 8385 *Parallel Linkage Bedder* is the solution for smooth and consistent bedding. Designed around the already proven Orthman 8375 *Row Crop Cultivator* row unit, the 8385 *Parallel Linkage Bedder* provides superb and consistent crop beds by the independent vertical action of each row unit.



**8385 ROW UNIT - LONG-TAIL OPTION**



**8385 ROW UNIT - STANDARD OPTION**

Featured on the 8385 is a depth band coulter that swiftly cuts through any residue, while maintaining accurate row unit depth to build the perfect crop beds in your field. A quick hand crank adjustment easily achieves the desired depth.

Also featured is a shear bolt protected 1" x 3" shank, furrowing shovel, stainless steel trash shield, and two rearward discs mounted on double bearing hubs. The two rearward discs may be adjusted to increase or decrease aggressiveness to achieve the desired crop bed.

The Orthman 8385 *Parallel Linkage Bedder* may be utilized on either a rigid, folding, or stacking Orthman toolbar. For information regarding the Orthman toolbar being used in conjunction with the 8385 *Parallel Linkage Bedder*, refer to that toolbar's respective operator's manual.

This manual is considered to be an integral component of the 8385 *Parallel Linkage Bedder* and is designed to educate the owner and/or operator(s) regarding safety, operation, maintenance, troubleshooting, and component identification. All personnel involved in the operation of this implement are responsible for reading and understanding entire manual content. This manual is designed to keep the operator safe and knowledgeable as well as prolong the life of the implement and maximize field efficiency. This manual should accompany the implement if it were ever to be sold.

We would like to thank you for placing your confidence in Orthman Mfg., Inc. Your 8385 *Parallel Linkage Bedder* is manufactured to meet the highest standards and is built with precision and strength to increase your agricultural operation's dependability and profitability.

***Thank you for choosing Orthman.***

To The Dealer:

Inspect the implement thoroughly after assembly to be certain it is functioning properly before delivering it to the customer. The following checklist is a reminder of points to cover. Check off each item as it is found satisfactory or after proper adjustment is made.

### ***Pre-Delivery Checklist***

- 1. All Hardware properly tightened.
- 2. Lubrication of grease fittings.
- 3. All decals properly located and readable.
- 4. All implement tools and options are installed and set.
- 5. Check overall condition of implement.
- 6. Make sure Operator's manual is included.

Date Set Up. \_\_\_\_\_ Signature. \_\_\_\_\_

### ***Delivery***

Review the operator's manual with the customer. Explain the following:

1. Introduce the machine to the customer. Give the customer this manual and encourage them to read it.
2. Make the customer aware of all the safety precautions that must be exercised when using and transporting this machine.
3. Make customer aware of the different tooling options available.
4. This machine does not come set to run in the field from the factory. The Field settings section in this manual is meant to help set the machine for optimal performance. Explain all operating adjustments.
5. Explain to the customer that the life expectancy of this machine depends on regular maintenance as directed in this manual.
6. Tell the customer to use the proper tools for service and make them aware of Orthman parts availability.
7. Write machine model number and serial number in the spaces provided below.

Date delivered. \_\_\_\_\_ Signature. \_\_\_\_\_

Model Number. \_\_\_\_\_

Serial Number. \_\_\_\_\_

## **INTRODUCTION**

### WARRANTY

Orthman warrants each new wholegood product to be free from defects in manufactured components and workmanship. This warranty is applicable only for the normal service life expectancy of the product or components, not to exceed twenty-four (24) consecutive months from date of purchase of the new Orthman product to the original purchaser.

Purchased components installed by Orthman (blades, bearings, controls, hoses, wheels, coulters, cylinders, fittings, etc.) shall be warranted by the respective manufacturer for a period of twelve (12) consecutive months from date of delivery of the new Orthman product to the original purchaser.

A completed online Warranty Registration for the original purchaser must be received by Orthman to activate warranty coverage. Non-receipt of warranty registration may void warranty coverage. The Orthman warranty is non-transferable.

Genuine Orthman replacement parts and components will be warranted for ninety (90) days from date of purchase, or the remainder of the original equipment warranty period, whichever is greater.

All warranty work is to be performed by an authorized Orthman dealer at the repairing dealer's location, unless otherwise approved by Orthman.

Under no circumstances, will this warranty cover any merchandise or component thereof, which, in the opinion of Orthman, has been subjected to misuse, unauthorized modifications or alteration, accident, collision with obstruction/ground, or if repairs have been made with parts other than those obtainable through Orthman.

Orthman warranty policies do not cover travel expenses, after-hours field/service time, overnight expenses, or expenses not related to regular shop labor rates or parts replaced during actual warranty repair. Orthman reserves the right to adjust warranty labor credits to believed normal repair times as directed by state law(s).

This warranty shall be limited to repairing or replacing, free of charge to the purchaser, any part, which Orthman's judgment shows evidence of such defect. Additionally, the defective part(s) shall be returned within thirty (30) days from the date of failure to Orthman through the dealer or distributor from whom the product was purchased or repaired; transportation charges prepaid.

This warranty shall not be interpreted to render Orthman liable for injury or damages of any kind or nature to person or property. This warranty does not extend to the loss of crops, loss of delay in harvesting/planting, or any expense or loss incurred for labor, substitute machinery, rental, or any subsequent reasons thereof.

Except as set forth above, Orthman shall have no obligation or liability of any kind on account of its equipment and shall not be liable for special or consequential damages. **Orthman makes no other warranty, expressed or implied, and, specifically disclaims any implied warranty or merchantability or fitness for a particular purpose.** Some states or provinces do not permit limitations or exclusions of implied warranties or incidental or consequential damages, so the limitations or exclusion in this warranty may not apply. This warranty is subject to any existing conditions of supply, which may directly affect ability to obtain materials or manufacture replacement parts.

Orthman reserves the right to make improvements in design or changes in specifications at any time, without incurring any obligation to owners of units previously sold; to include, but not limit to engineering prototype machines. No one is authorized to alter, modify, or enlarge this warranty nor the exclusions, limitations, and reservations.

---

© Copyright 2014  
Orthman Manufacturing Inc.  
Lexington, Nebraska  
All rights reserved.

Orthman provides this manual without warranty of any kind, expressed or implied. This manual reflects the product at the time of publication. All information within is based upon current information on the publication date. Orthman assumes no responsibility for damages incurred due to the use of the illustrations, information, and specifications within this publication.

**TABLE OF CONTENTS****INTRODUCTION**

General Information - 8385 Parallel Linkage Bedder.....	1 - 1
Delivery Checklist .....	1 - 2
Warranty Information .....	1 - 3
Table of Contents .....	1 - 4

**IMPORTANT SAFETY INFORMATION**

Farm Safety.....	2 - 1
Your Protection - Equipment Safety - Safety Alert Symbol .....	2 - 3
Signal Words - Shutdown and Storage .....	2 - 4
Safe Transport - Warning and Safety Lights .....	2 - 5
Safe Operation - No Riders.....	2 - 6
Practice Safe Maintenance.....	2 - 7
Practice Safe Maintenance - Prepare for Emergencies .....	2 - 8
Anhydrous Ammonia - Liquid Fertilizer Precautions - Safety Never Hurts .....	2 - 9
Safety Decals .....	2 - 10
Orthman Decals .....	2 - 11
Orthman Serial Tag.....	2 - 12

**PREPARATION AND SETUP**

Standard Row Unit Component Identification.....	3 - 1
Preparing the Implement - Implement-to-Tractor Connection .....	3 - 2

**TOOLING OPTIONS AND INSTALLATION**

Row Unit Mount - Mounting of Row Units.....	4 - 1
Long Tail and Secondary Tooling Shank - Installation .....	4 - 2

**TABLE OF CONTENTS****FIELD SETTINGS**

Toolbar Orientation .....	5 - 1
Toolbar Height .....	5 - 2
Row Unit Down Pressure .....	5 - 3
Row Unit Depth Adjustment .....	5 - 4
Listing Disc Adjustment .....	5 - 5

**TROUBLESHOOTING**

Row unit tooling does not penetrate soil. Wing row units float upward .....	6 - 1
---	-------

**MAINTENANCE**

Practice Safe Maintenance .....	7 - 1
Torque Specifications .....	7 - 2
Lubrication .....	7 - 3
Lubrication - Implement Inspection .....	7 - 4
Implement Storage .....	7 - 5

**PARTS IDENTIFICATION**

Mount and Parallel Linkage Assembly .....	8 - 1
Coulter Fork Assembly .....	8 - 2
Bedding Attachment Assembly .....	8 - 4
Depth Band Coulter Assembly .....	8 - 5

### Farm Safety

Contrary to the popular image of fresh air and peaceful surroundings, a farm is not a hazard-free work setting. Every year, thousands of farm workers are injured and hundreds more die in farming accidents. According to the National Safety Council, agriculture is the most hazardous industry in the nation.

### How You Can Improve Farm Safety

You can start by increasing your awareness of farming hazards and making a conscious effort to prepare for emergency situations including fires, vehicle accidents, electrical shocks from equipment and wires, and chemical exposures. Be especially alert to hazards that may affect children and the elderly. Minimize hazards by carefully selecting the products you buy to ensure that you provide good tools and equipment. Always use seat belts when operating tractors, and establish and maintain good housekeeping practices. Here are some other steps you can take to reduce illnesses and injuries on the farm:

- Read and follow instructions in equipment operator’s manuals and on product labels.
- Inspect equipment routinely for problems that may cause accidents.
- Discuss safety hazards and emergency procedures with your workers.
- Install approved rollover protective structures, protective enclosures, or protective frames on tractors.
- Make sure that guards on farm equipment are replaced after maintenance.
- Review and follow instructions in material safety data sheets (MSDSs) and on labels that come with chemical products and communicate information on these hazards to your workers.

### Health and Safety Hazards on Farms

Farm workers including farm families and migrant workers are exposed to hazards such as the following:

Danger	Potential Effect or Injury	Prevention
Chemicals/Pesticides	Skin and respiratory injury or death	MSDS and proper Personal Protective Equipment. Review Manufacturers data sheets
Cold	Illness, Frostbite or death	Dress properly for the day.
Dust	Respiratory injury or explosive combinations	Be aware of your surroundings and activity
Electricity	Shock, burns, fire, death	Use a qualified professional for wiring dangerous electrical devices. Never overload a circuit. Replace damaged electrical devices or cords. Electrical tape will not insulate you from injury.
Grain bins, Silos	Entrapment, Suffocation, Explosion from formation of dangerous gases and poisoning.	Make sure the bin is properly ventilated and maintained. Never walk the grain.
Hand tools	Injury including cuts abrasions, electrocution, strains, sprains and death	Make sure you hand tools are in good condition. Never leave a damaged tooling accessible for someone else to use.
Highway traffic	Collisions resulting in injury or death	Follow regulations, stay alert. Avoid alcohol and use of communication devices while driving
Lifting & lifting devices	Back injury, sprains, strains. Falling material resulting in being struck or crushed by heavy material	Use proper lifting technique. Get help when the load is too heavy. Inspect chains, straps or cables routinely to make sure they are in good condition.
Livestock handling	Serious injury or death resulting from being pinned struck or trampled.	Always make sure you have adequate room and an escape route
Machinery/Equipment	Cuts, abrasions, amputations, death.	Thoroughly read and understand your Owners Equipment Manual. Never operate the equipment without guards in place. Make sure the equipment can not be energized or otherwise put into operation while you are working on it.
Manure pits	Explosion from formation of dangerous gases. Suffocation. Poisoning	Proper maintenance.
Mud	Sprains, strains, entrapment and suffocation. Eye injury and skin irritation.	Proper Personal Protective Equipment. In some conditions a "Spotter" may be needed.
Noise	Hearing damage	Personal Protective Equipment.
Ponds	Drowning	Wear a life preserver and make sure help is readily available.
Slips/Trips/Falls	Sprains, strains, back and neck injury, bone breaks or death	Keep work area free from clutter and organized. If working on anything elevated make sure you have appropriate guarding and/or fall protection such as a harness and lanyard.
Sun/Heat	Sunburn, Heat Stroke, shock, death	Use common sense on excessively hot days, use sun screen, wear a hat and stay hydrated.
Toxic gases	Skin and respiratory injury or death. Explosion.	MSDS and proper Personal Protective Equipment. Review Manufacturers data sheets
Tractors	Cuts, abrasions, amputations, death.	Thoroughly read and understand your Owners Equipment Manual. Never operate the equipment without guards in place. Anti-roll over devices.
Wells	Electrocution, amputation, death	Avoid contact with water while working on an electrical device. Always be sure the equipment can/will not be energized during repair or maintenance. Make sure all guarding is in place.
Severe Weather	Electrocution, "struck by" injuries, death	Move to a safe place. Lightening, hail and tornadoes are unpredictable.

Orthman Manufacturing, Inc. does not limit the potential effects or injuries nor prevention measures to those listed above. They are provided solely as a guideline to making your farm life safer. Always consult your Owner/Operators Manual for specific tool and equipment safety requirements.

## ***SAFETY INFORMATION***

### High Risk Factors on Farms

The following factors may increase risk of injury or illness for farm workers:

- **Age**—Injury rates are highest among children age 15 and under and adults over 65.
- **Equipment and Machinery**—Most farm accidents and fatalities involve machinery. Proper machine guarding and doing equipment maintenance according to manufacturers' recommendations can help prevent accidents.
- **Protective Equipment**—Using protective equipment, such as seat belts on tractors, and personal protective equipment (such as safety gloves, coveralls, boots, hats, aprons, goggles, face shields) could significantly reduce farming injuries.
- Take precautions to prevent entrapment and suffocation caused by unstable surfaces of grain storage bins, silos, or hoppers. Never "walk the grain."
- Be aware that methane gas, carbon dioxide, ammonia, and hydrogen sulfide can form in unventilated grain silos and manure pits and can suffocate or poison workers or explode.
- Take advantage of safety equipment, such as bypass starter covers, power take-off master shields, and slow-moving vehicle emblems.
- **Medical Care**—Hospitals and emergency medical care are typically not readily accessible in rural areas near farms.

### The Benefits of Improved Safety and Health Practices

Orthman Manufacturing Provides this document in the hope that everyone that has a job to do, does it SAFELY. Our goal and yours should be to end each day in the best possible health. Better safety and health practices reduce fatalities, injuries, and illnesses as well as associated costs such as workers' compensation insurance premiums, lost production, and medical expenses. A safer and more healthful workplace improves morale and productivity.



**⚠ FOR YOUR PROTECTION**

**READ AND UNDERSTAND THE ENTIRE CONTENT OF THIS MANUAL BEFORE OPERATING OR SERVICING IMPLEMENT.** Read and understand all operator manuals for the machinery used in conjunction with your Orthman equipment.

- Carefully **READ ALL SAFETY DECALS** in this manual as well as on the implement. Keep implement clean so decals are easily visible. Keep all safety decals in good, clean, and legible condition. Immediately replace damaged and/or missing decals. Replacement decals are available from your Orthman dealer.
- Learn to operate the implement and all components properly. Do not let others operate implement without proper instruction. Unauthorized implement modifications may impair function and safety. If you do not understand any content in this manual or need assistance, contact your Orthman dealer.

**⚠ EQUIPMENT SAFETY GUIDELINES**

Operator safety is the primary concern when designing an Orthman implement. Orthman integrates as many safety features into the implement as possible. You can avoid many hazards and possible accidents by observing precautions in this safety section.

- Insist that yourself and personnel working with and around you follow all safety precautions. Be cautious when working with or around implement to avoid injury.

**SAFETY ALERT SYMBOL**

The **SAFETY ALERT SYMBOL** warns of potential hazards to personal safety and that extra precautions must be taken. When you see this symbol, carefully read the message(s) that follow. Follow all recommended precautions and safe operating practices in this manual.

NOTE: Hazard control and accident prevention are dependent upon the safety awareness and proper training of personnel involved in the operation of this implement.

## SAFETY INFORMATION

### **BE AWARE OF SIGNAL WORDS**

**SIGNAL WORDS** designate a degree or level of **HAZARD** seriousness. These signal words include:



**DANGER** indicates a hazardous situation that, if not avoided, will result in death or serious injury. **DANGER** is limited to extreme situations, typically for machine components which for functional purposes, cannot be guarded.



**WARNING** indicates a potentially hazardous situation that, if not avoided, could result in death or serious injury. **WARNING** includes hazards that are exposed when safety guards are removed. Warning may also be used to alert against unsafe practices.



**CAUTION** indicates a potentially hazardous situation that, if not avoided, may result in minor or moderate injury. **CAUTION** may also be used to alert against unsafe practices.

### **SHUTDOWN AND STORAGE**

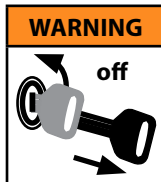

**AVOID CRUSHING.** Make sure all personnel are clear of the implement. Lower implement to the ground, place tractor in park, turn off engine, and remove key.



#### **USE BAR STANDS AND CYLINDER STOPS TO SUPPORT THE IMPLEMENT.**

Store implement on a clean, dry, and level surface. An uneven surface could cause implement to shift or fall, resulting in injury or death, as well as implement damage. Securely support all implement components that must be raised. Store implement away from human activity.

### **SAFE TRANSPORT**

- Engage transport locking devices prior to transport.
- Plan your route to avoid traffic. Yield to traffic in all situations.
- Maximum transport speed is 20 mph (32 kph). Various conditions will require reduced speed. Travel at speeds that allow for adequate control of stopping and steering.

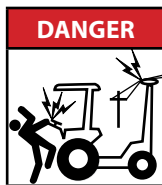

**AVOID ELECTROCUTION.** Be aware of overhead power lines. Contact or close proximity to power lines can result in injury or death. Use extreme care when operating implement near power lines.



- Know implement transport height and gross weight. Avoid overhead obstructions not allowing your transport height. Do not use bridges rated below combined implement and tractor weight.
- Make sure a slow moving vehicle (SMV) placard is mounted to the implement and is easily visible to other motorists.
- Make allowances for implement size when transporting. Sudden braking can cause a towed load to swerve and/or rollover. Never use independent braking with implement in tow as loss of control and/or rollover can result. Reduce speed if towed implement is not equipped with brakes.
- Do not coast. Always keep tractor or towing device in gear to provide engine braking when traveling downhill.
- Comply with state and local laws governing implement transport.



### **WARNING AND SAFETY LIGHTS**

**CAUTION**

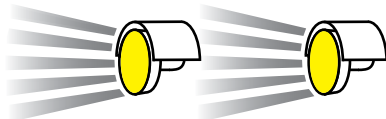

- Oversized implements and slow moving vehicles create a hazard when transported on public roads.
- Make sure all warning, safety lights, and turning signals are working and clean. Use safety lighting when using public roads day and night. Replace missing or damaged lights immediately. Comply with state and local laws governing implement safety lighting.
- A safety lighting package, conforming to implement lighting standard ANSI/SAE S279.12, if not supplied with, is available for addition to your equipment. Contact your Orthman dealer for safety lighting package information. Refer to toolbar operator's manual for safety lighting package installation and adjustment.

## SAFETY INFORMATION

### **SAFE OPERATION**

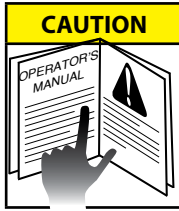

#### **READ AND UNDERSTAND THE ENTIRE CONTENT OF THIS MANUAL BEFORE OPERATING OR SERVICING IMPLEMENT.**

Implement is to be operated by qualified personnel only. Never let children operate implement. A complete understanding of safety precautions, operation, and maintenance is mandatory before implement use.

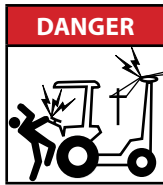

**AVOID ELECTROCUTION.** Be aware of overhead power lines. Contact or close proximity to power lines can result in injury or death. Use extreme care when operating implement near power lines.

- Know implement transport height and gross weight. Avoid overhead obstructions not allowing your transport height. Do not use bridges rated below combined implement and tractor weight.



**AVOID ROLLOVER.** Do not fold or unfold implement and avoid sharp turns when on a hillside, as shift of weight could cause rollover. Operate implement at a safe distance from terrain irregularities and other obstructions that could cause rollover.



**AVOID CRUSHING.** Make sure all personnel are clear of implement at all times implement is in motion. Be aware of obstructions above, below, and around implement when in operation or transport. Injury or death can result from being struck by the implement.



### **NO RIDERS**

**NEVER ALLOW RIDERS ON TRACTOR OR IMPLEMENT.** Riders hinder operator visibility and can be thrown from the implement and/or be struck by foreign objects resulting in injury or death.

### **PRACTICE SAFE MAINTENANCE**

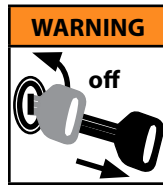

Proper maintenance is your responsibility. Maintenance neglect and/or poor maintenance practices can result in injury or death. Always use the proper tools to maintain implement.

**AVOID CRUSHING.** Make sure all personnel are clear of the implement. Lower implement to the ground, place tractor in park, turn off engine, and remove key.



#### **USE BAR STANDS AND CYLINDER STOPS TO SUPPORT THE IMPLEMENT.**

Store implement on a clean, dry, and level surface. An uneven surface could cause implement to shift or fall, resulting in injury or death, as well as implement damage. Securely support all implement components that must be raised. Store implement away from human activity.



#### **AVOID ENTANGLEMENT.** Never lubricate or service implement in motion.

Keep away from power driven parts when in motion. Disengage power sources prior to maintaining implement. Injury or death can result from contact with power driven parts when in motion.



**AVOID CRUSHING.** Do not stand between the tractor and implement when connecting or disconnecting implement. Injury or death can result from being trapped between the tractor and implement.



Escaping pressurized hydraulic fluid can penetrate skin, resulting in injury or death. Relieve hydraulic system pressure before connecting or disconnecting tractor. Use cardboard or wood, **NOT BODY PARTS**, to check for suspected hydraulic leaks. Wear protective gloves and safety glasses or goggles when working with hydraulic systems. If an accident occurs, see a doctor immediately for proper treatment.

## SAFETY INFORMATION

### **⚠ PRACTICE SAFE MAINTENANCE**



- Never operate a combustion engine in an enclosed area. Make sure there is adequate ventilation. Exhaust fumes can cause asphyxiation.



- Service tires safely. Tire and rim separation can result in serious injury or death. Do not over inflate tires. Only mount or dismount tires if you possess the proper equipment, otherwise contact a trained professional. Always maintain correct tire pressure. Inspect tires and wheels daily. Do not operate tires with inadequate pressure, cuts, visible damage, or missing hardware.



- Be extremely careful working around unshielded sharp edges. Injury may result from contact with sharp edges.
- Keep all parts in good condition and properly installed. Replace damaged or missing parts immediately.
- Remove tools and unused parts prior to implement operation.

### **⚠ PREPARE FOR EMERGENCIES**



- Be prepared for a fire. Keep a readily accessible fire extinguisher at all times.
- Keep a readily accessible stocked first aid kit and emergency phone numbers for your doctor, hospital, ambulance, and fire department.
- Wear protective clothing and equipment. Wear clothing appropriate for the situation. Protect your eyes, ears, hands, and feet with the use of protective goggles, ear plugs, gloves, boots, etc.

**⚠ ANHYDROUS AMMONIA - NH<sub>3</sub>  
LIQUID FERTILIZER**



**ANHYDROUS AMMONIA (NH<sub>3</sub>) AND LIQUID FERTILIZER APPEARS HARMLESS. DIRECT EXPOSURE TO NH<sub>3</sub> OR LIQUID FERTILIZER IS EXTREMELY DANGEROUS AND CAN RESULT IN INJURY AND/OR DEATH.**

- Keep a clean supply of water readily accessible in case of exposure to NH<sub>3</sub> or liquid fertilizer.
- Wear protective goggles and gloves when working with NH<sub>3</sub> or liquid fertilizer. Be sure all persons involved in the operation are properly trained concerning the dangers and precautions involved in the application of NH<sub>3</sub> or liquid fertilizer.
- If you choose to apply NH<sub>3</sub> or liquid fertilizer, it is advisable to consult documented information regarding safe handling and application of NH<sub>3</sub> or liquid fertilizer. Information is available from the following recognized sources:

1. American National Standards Institute - [www.ansi.org](http://www.ansi.org) - (212) 642-4900
2. Material Safety Data Sheets - MSDS - [www.msdsonline.com](http://www.msdsonline.com)
3. National Safety Council - [www.nsc.org/necas](http://www.nsc.org/necas)
4. The Fertilizer Institute - [www.tfi.org](http://www.tfi.org)
5. United States Department of Transportation - D.O.T. - [www.dot.gov](http://www.dot.gov)
6. Compressed Gas Association - [www.cganet.com](http://www.cganet.com)

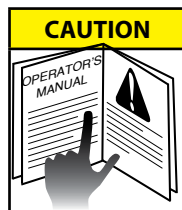

**⚠ SAFETY NEVER HURTS**

**READ AND UNDERSTAND THE ENTIRE CONTENT OF THIS MANUAL BEFORE OPERATING OR SERVICING IMPLEMENT.**

- Understand all implement functions.
- Never stand between tractor and implement when connecting or disconnecting implement.
- Be aware of all surroundings before moving implement.
- Operate implement from operator's seat only.
- Never mount or dismount a moving tractor.
- Never leave engine running when implement is unattended.
- Keep away from power driven parts when in motion.
- Make sure all personnel are clear before lowering implement to the ground.

## SAFETY INFORMATION

**DANGER**

RED

**WARNING**

ORANGE

**CAUTION**

YELLOW

### SAFETY DECALS

Safety decals promote awareness and knowledge concerning safe operation and maintenance of the implement.

Carefully **READ ALL SAFETY DECALS** in this manual as well as on the implement. Keep implement clean so decals are easily visible. Keep all decals in good and legible condition. Immediately replace damaged and/or missing decals. Replacement decals are available from your Orthman dealer.

To install decals: Thoroughly clean area where decal is to be placed and attach decal void of bubbles. Refer to this safety information section for proper decal placement.



**IMPORTANT**

Equipment operators should understand the enclosed manual before operating this equipment. Replacement manual, call 308-324-4654

Orthman Mfg., Inc. - 75765 Rd. 435 - Lexington, NE 68850 153-103

(manual enclosure)

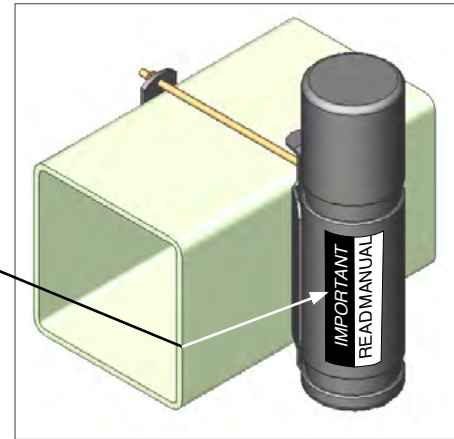

**CAUTION**

1. Read and understand all operator manuals before implement use.
2. Follow all tractor or towing device operating procedures and safety guidelines.
3. Do not allow riders on implement.
4. Lower implement to the ground, place tractor in park, turn off engine, and remove key. Wait for all moving parts to come to a complete stop before working on implement.
5. Be extremely careful working around unshielded sharp edges.
6. Make sure all safety lighting and decals are clean. Use hazard lights when in transport.
7. Engage all safety devices before transporting or working beneath implement.
8. Contact or close proximity to power lines can result in electrocution.
9. Review all safety instructions with all operators on a frequent basis.

153-044

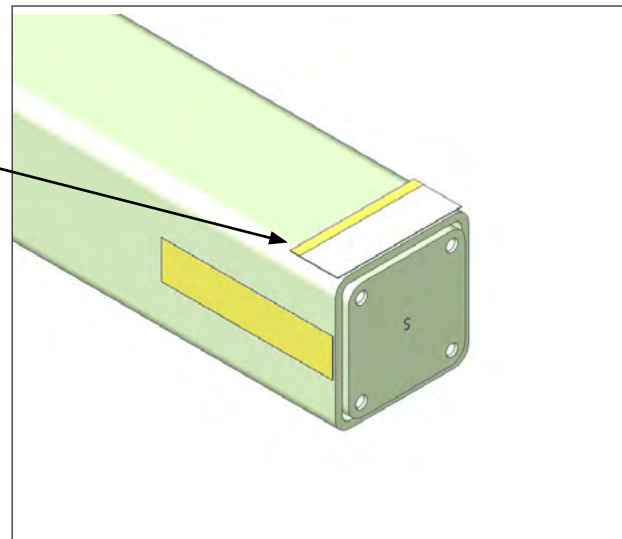

END OF WING



**ORTHMAN DECALS**



(front left and rear left of toolbar)

153-430

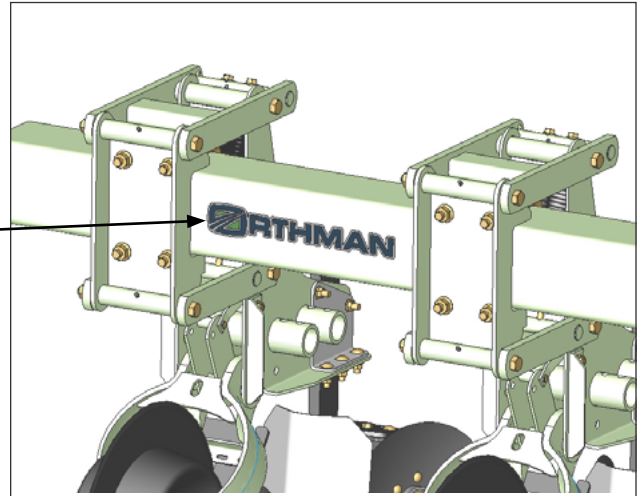

(front right and rear right of toolbar)

153-433



### ORTHMAN SERIAL TAG

The Orthman serial tag contains valuable information. The model and serial numbers provide Orthman dealers and the Orthman Service Department with the exact specifications of your implement if any warranty or service issues need to be addressed.



153-011

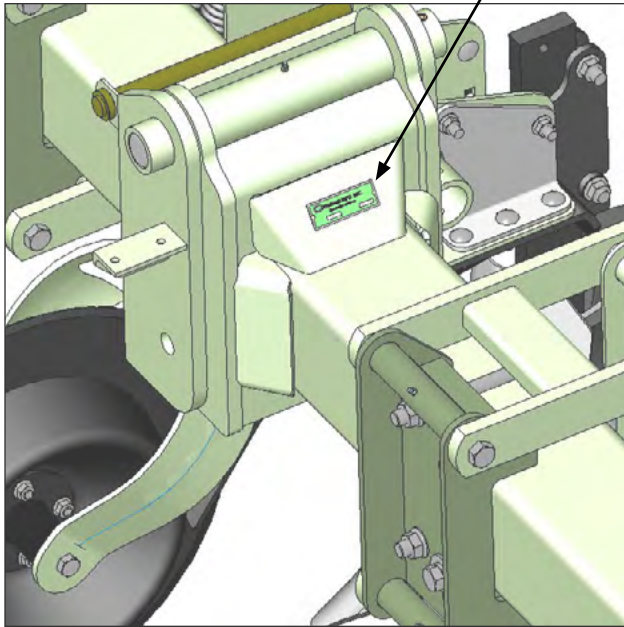

(serial tag location on vertical folding toolbar)

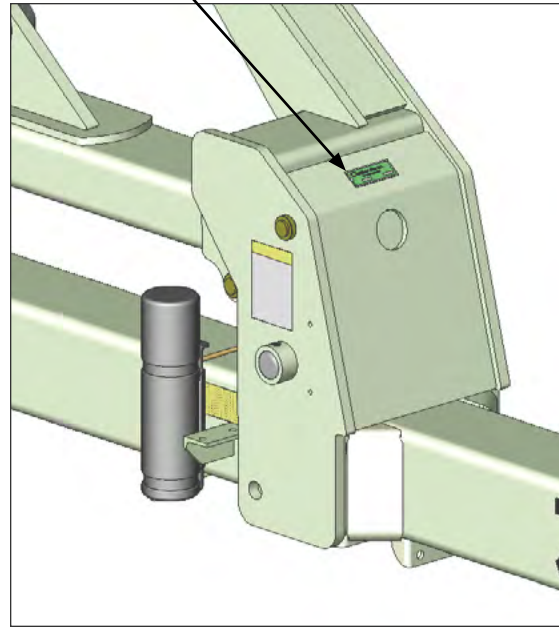

(serial tag location on stacking toolbar)

**STANDARD ROW UNIT  
COMPONENT IDENTIFICATION**

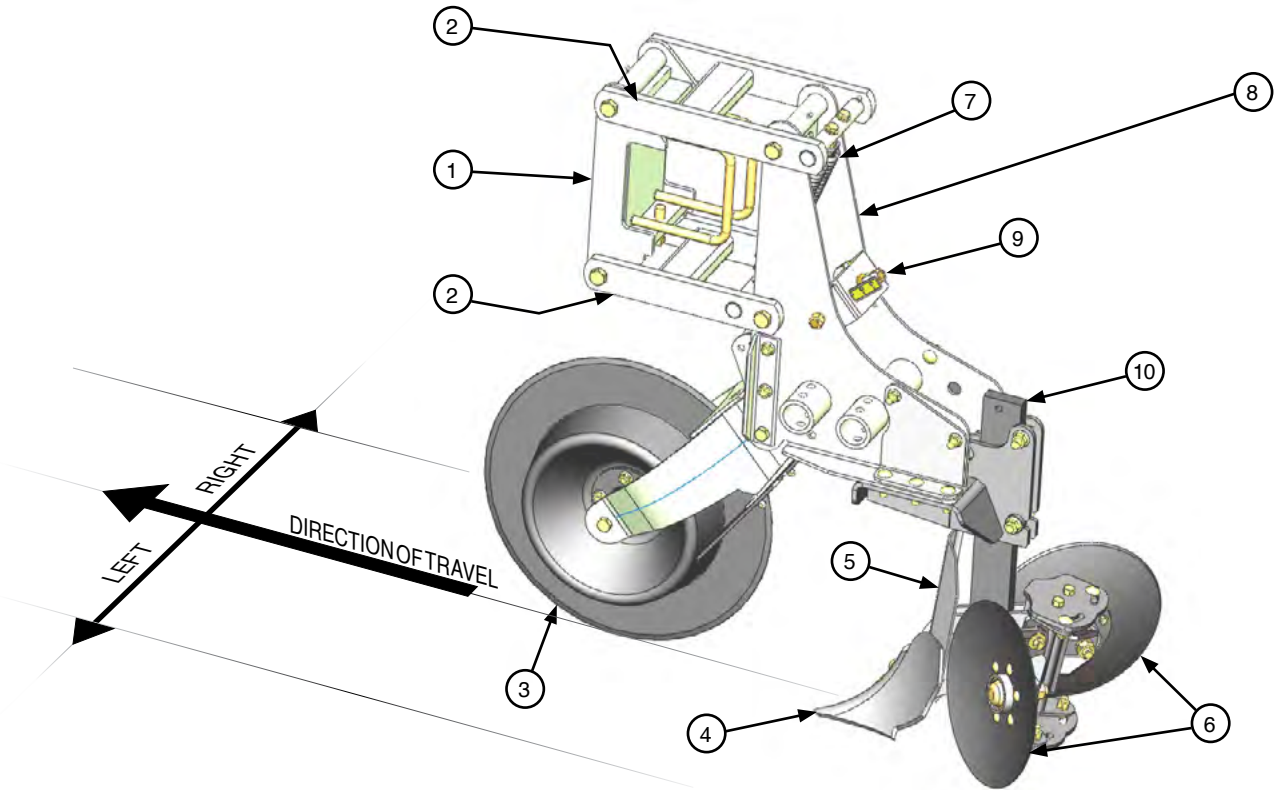

**NOTE:** Right and left as illustrated above and referenced from this point on, is determined by facing the same direction the implement will travel while in use.

- 1. MOUNT.** A wrap-around mount provides a robust row unit foundation.
- 2. PARALLEL LINKAGES.** Parallel linkages allow the row unit to operate independently of the toolbar for constant depth control in uneven field conditions.
- 3. DEPTH BAND COULTTER ASSEMBLY.** The depth band cuts through surface and sub-surface residue to eliminate interference with the while it simultaneously maintains a precise control of seed-bed depth.
- 4. FURROWING SHOVEL.** Designed to dig, lift, and guide the soil towards the listing discs.
- 5. RESIDUE SHIELD.** Built of non-corrosive stainless steel to keep residue out of row unit tooling.
- 6. LISTING DISCS.** Adjustable discs for moving soil from the furrow to the seed bed.
- 7. DOWN PRESSURE SPRINGS.** Two adjustable down pressure springs per row unit supply down pressure to assist with row unit tooling soil penetration.
- 8. MAINFRAME.** The row unit mainframe serves as the primary mount for row unit tooling.
- 9. ROW UNIT DEPTH ADJUSTMENT ASSEMBLY.** Using a crank and rotating the adjustment rod clockwise or counter-clockwise, this assembly moves the depth band coultter up (for deeper tillage) or down (for shallower tillage).
- 10. TOOLING SHANK.** 1" x 3" shank acts as the "backbone" for the row unit tooling.

## PREPARATION AND SETUP

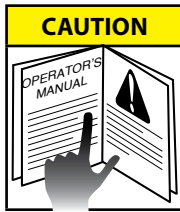

### PREPARING THE IMPLEMENT

Field adjustments are illustrated and explained in the field settings section of this manual. Refer to the Orthman toolbar operator's manual used in conjunction with the 8385 PL Bedder for toolbar preparation. Read and understand operator manuals for machinery used in conjunction with the 8385 PL Bedder.



Before each use, check hardware for wear and proper torque. Replace damaged or missing hardware with hardware of an identical grade to restore implement to original specifications.



Be sure implement is properly lubricated before use. Only use high quality multi-purpose grease.

### IMPLEMENT TO TRACTOR CONNECTION



**AVOID CRUSHING.** Do not stand between tractor and implement when connecting or disconnecting implement. Injury or death can result from being trapped between the tractor and implement.

**AVOID CRUSHING.** Make sure all personnel are clear of the implement. Lower implement to the ground, place tractor in park, turn off engine, and remove key.



**USE BAR STANDS TO SUPPORT THE IMPLEMENT.** Park implement on a clean, dry, and level surface. An uneven surface could cause implement to shift or fall, resulting in injury or death, as well as implement damage. Securely support all implement components that must be raised.

Refer to your tractor operator's manual for proper use of the 3-point hitch to make the connection between the implement and tractor.

Refer to the toolbar operator's manual for proper connection of the toolbar hydraulic hoses.

## TOOLING OPTIONS AND INSTALLATION

### INDIVIDUAL ROW UNITS

In most cases, the 8385 PL Bedder is purchased as a machine and row units will be factory installed to the toolbar. Individual 8385 PL Bedder row units can be purchased separate of a toolbar. Use the instructions below to properly mount the 8385 PL Bedder row unit to a 7 sq. toolbar.

### MOUNTING OF ROW UNITS



**AVOID CRUSHING.** Make sure all personnel are clear of the implement. Lower implement to the ground, place tractor in park, turn off engine, and remove key.

**USE BAR STANDS TO SUPPORT THE IMPLEMENT.** Park implement on a clean, dry, and level surface. An uneven surface could cause implement to shift or fall, resulting in personal injury or death, as well as implement damage. Securely support all implement components that must be raised. Remove buildup of grease, oil, or debris prior to installing row unit mounts.

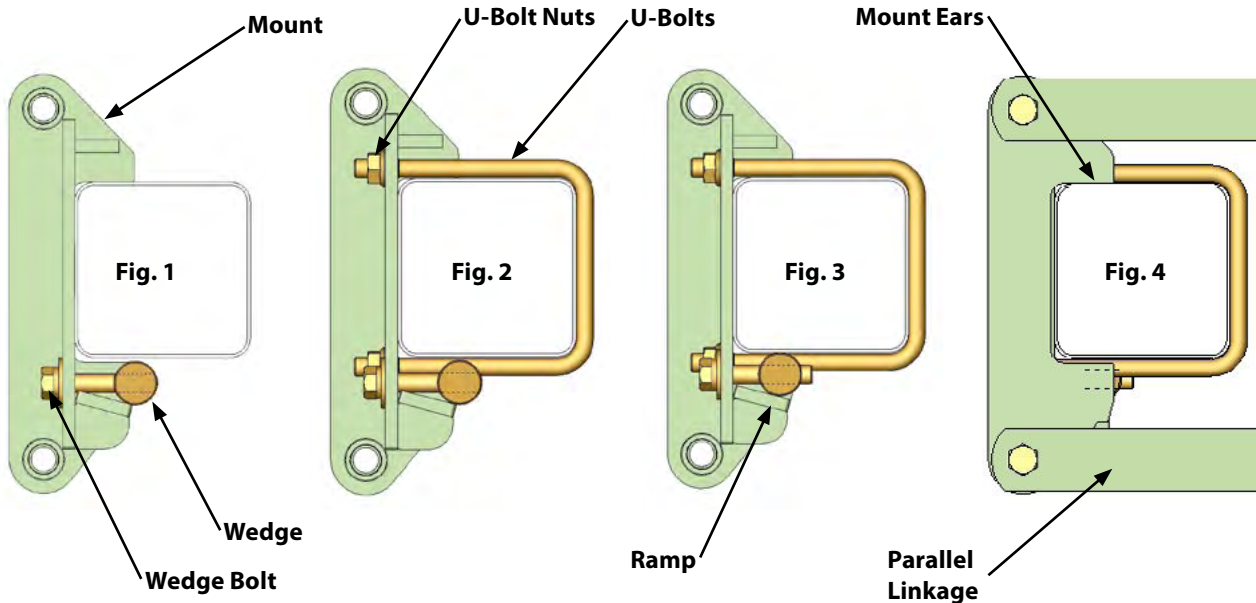

1. Remove mount from front of parallel linkage of row unit.
2. Leave wedge bolt installed, slightly start threads into wedge and position on toolbar. (fig. 1)
3. Install U-bolts and snug up evenly top and bottom on each nut until mount is snug on toolbar. (fig. 2)
4. Tighten wedge bolt until wedge moves up the ramp and becomes tight against the bottom of the toolbar. (fig. 3) Mount ears should come tight against top of toolbar at this time. (fig. 4) If mount ears do not come tight against top of bar, loosen U-bolts slightly and retry.
5. Finish tightening U-bolt nuts evenly. U-bolt nuts are locking nuts and may tighten slowly.
6. Install row unit parallel linkage to mount. (fig. 4)
7. When properly installed, mount should be square and top ears of mount should both contact top side of toolbar. (fig. 4)
8. After initial break in period of field operation, check all hardware for tightness.

**NOTE:** IT IS IMPORTANT THAT THE TONGUE TAB MOUNT PLATES CLAMP TIGHT ON THE TONGUE TAB. RECOMMENDED TOOLS: IMPACT WRENCH, 1 1/2" IMPACT SOCKET, 1 1/2" END WRENCH.

### LONG TAIL AND SECONDARY TOOLING SHANK

A long tail frame attachment is compatible with the 8385 PL Bedder standard row unit to add more versatility to the machine and allows for the use of a secondary tooling shank to convert the 8385 PL Bedder into an 8375 cultivator row unit. Use the instructions below to properly install the long tail frame and secondary tooling shank.



### INSTALLATION

**AVOID CRUSHING.** Make sure all personnel are clear of the implement. Lower implement to the ground, place tractor in park, turn off engine, and remove key.

**USE BAR STANDS TO SUPPORT THE IMPLEMENT.** Park implement on a clean, dry, and level surface. An uneven surface could cause implement to shift or fall, resulting in personal injury or death, as well as implement damage. Securely support all implement components that must be raised.

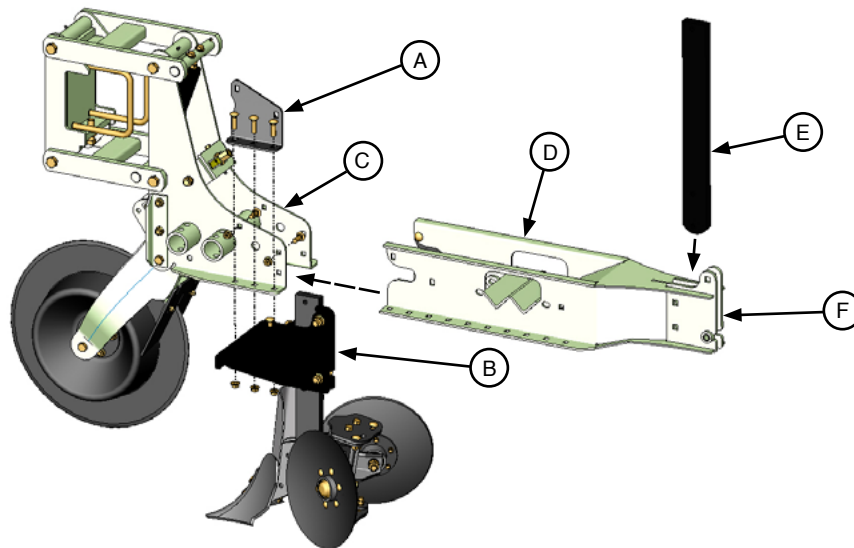

1. Remove the two upper accessory clamp saddles (A) and the accessory clamp (B) from the row unit mainframe (C).
2. Situate the long tail section (D) onto the row unit mainframe (C) where the accessory clamp saddles (A) were previously mounted.
3. Replace the accessory clamp (B) below the row unit mainframe (C) and the accessory clamp saddles (A) on top of the long tail section (D).
4. Replace carriage bolts and re-tighten.
5. Place the secondary tooling shank (E) into the the long tail section accessory clamp (F).
6. Clamp in place with provided hardware.



### TOOLBAR ORIENTATION



**PLACE TRACTOR IN PARK AND REMOVE KEY BEFORE DISMOUNTING TRACTOR TO ADJUST IMPLEMENT.**

**NEVER ALLOW RIDERS ON TRACTOR OR IMPLEMENT.** Riders hinder operator visibility and can be thrown from the implement and/or be struck by foreign objects resulting in injury or death.

**NOTE:** WHEN SETTING TOOLBAR HEIGHT AND ORIENTATION, DISREGARD ROW UNIT PERFORMANCE. TOOLBAR HEIGHT AND ORIENTATION MUST BE ESTABLISHED PRIOR TO TOOLING ADJUSTMENT.

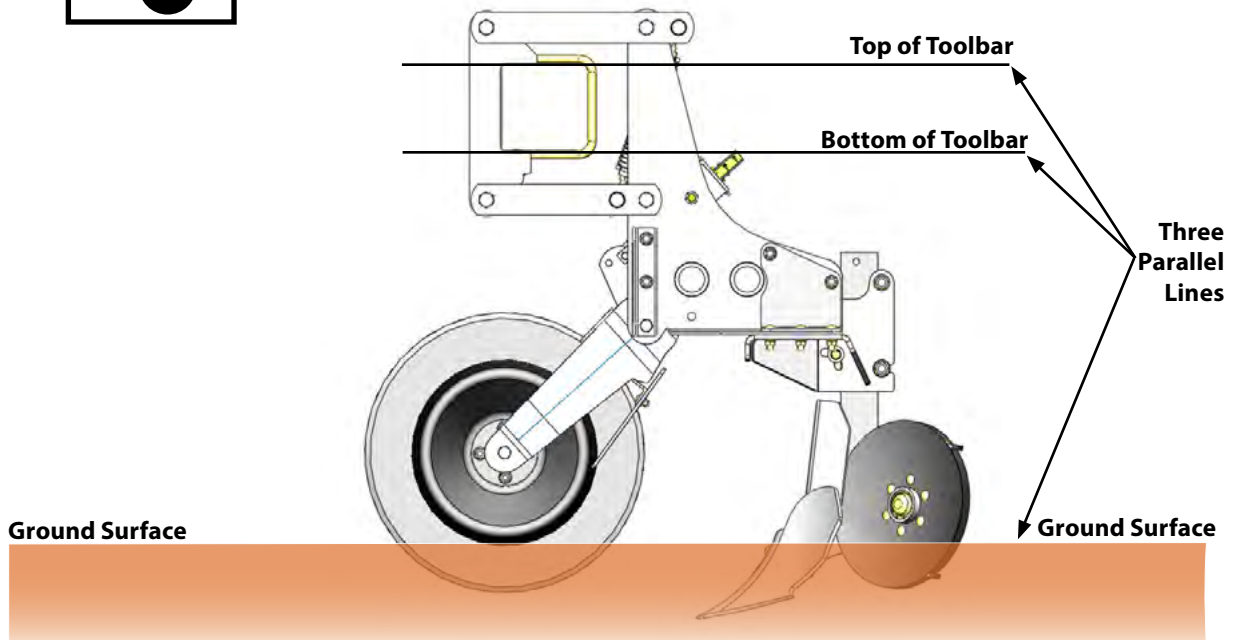

The top and bottom of the toolbar must operate parallel with the ground surface. Adjustment of tractor three point third link, lift assist wheels, and/or toolbar gauge wheels, if equipped, will allow the toolbar to operate parallel with the ground surface.

The bottom of the toolbar should operate approximately 30 - 32 inches above the ground surface. Use tractor lower hitch stop, lift assist wheels, and/or toolbar gauge wheels, if equipped, to set desired toolbar height.

Have an assistant pull the tractor and implement slowly forward in the field position as you view the end of the toolbar from a safe distance. Observe toolbar height and orientation while in operation. Make adjustments accordingly until the top and bottom of the toolbar operate parallel with the ground surface and the bottom of the toolbar operates approximately 30 - 32 inches above the ground surface. (as pictured above)

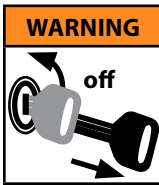

### **⚠ TOOLBAR HEIGHT**

**PLACE TRACTOR IN PARK AND REMOVE KEY BEFORE DISMOUNTING TRACTOR TO ADJUST IMPLEMENT.**

**NEVER ALLOW RIDERS ON TRACTOR OR IMPLEMENT.** Riders hinder operator visibility and can be thrown from the implement and/or be struck by foreign objects resulting in injury or death.

After desired toolbar height and orientation is established, set tractor lower hitch stop, lift assist wheels, and/or toolbar gauge wheels, if equipped.

**NOTE:** LARGER IMPLEMENTS MAY REQUIRE LIFT ASSIST WHEELS AND/OR TOOLBAR GAUGE WHEELS TO SUPPORT TOOLBAR WEIGHT. LIFT ASSIST WHEELS AND/OR TOOLBAR GAUGE WHEELS DISPLACE A PORTION OF TOOLBAR WEIGHT TO ALLOW MAXIMUM PARALLEL LINKAGE TRAVEL.

**NOTE:** SMALLER IMPLEMENTS MAY OPERATE WITHOUT LIFT ASSIST WHEELS AND/OR TOOLBAR GAUGE WHEELS. THE TRACTOR HITCH WILL BEAR A PORTION OF THE TOOLBAR WEIGHT BY SETTING A LOWER HITCH STOP ON THE TRACTOR THREE POINT HITCH CONTROL.

### **ROW UNIT DEPTH**

Effectively, the depth band coulter assembly provides consistent row unit tooling depth by governing soil penetration. Adjustable down pressure springs supply row unit down pressure to assist with row unit soil penetration. Parallel linkages, with the ability to travel vertically, allow row units to operate independent of the toolbar. The depth band, down pressure springs, and parallel linkages should allow the toolbar to serve as a towing device, allowing uniform tillage despite terrain variations.

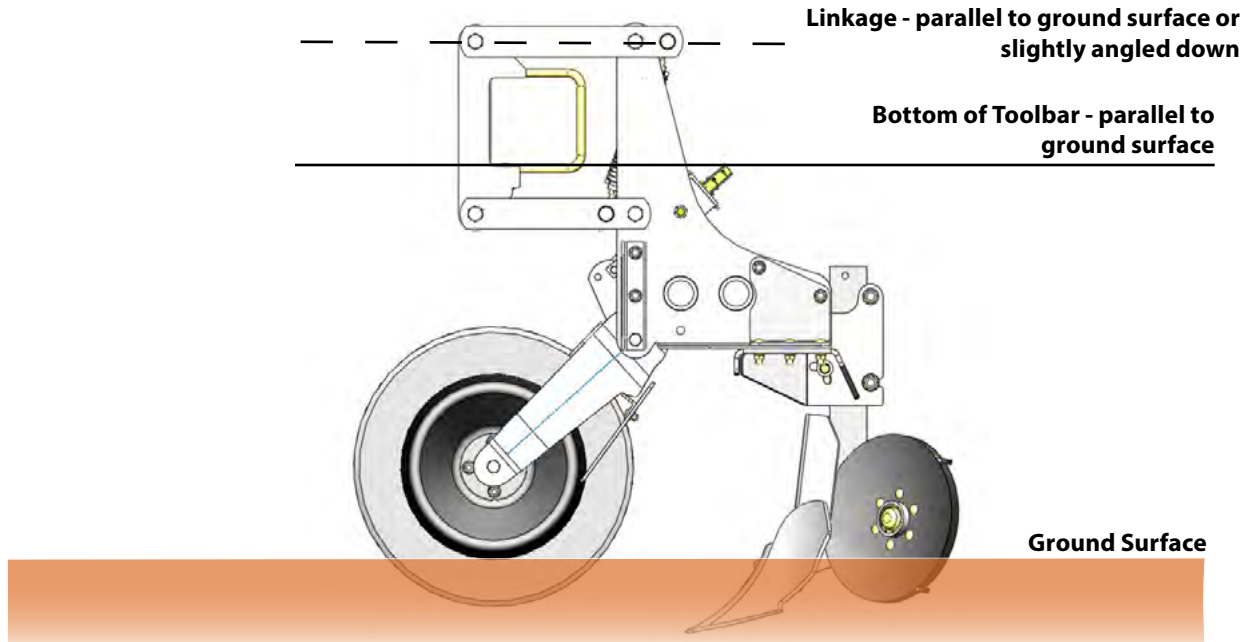

For the toolbar to serve as a towing device, the ground surface, the toolbar and linkage must generally operate parallel to one another when in the field position. (In most field conditions the linkage will operate at a slight downward angle.) The depth band coulter assembly should allow the toolbar to operate at the desired height and provide consistent row unit tooling depth by governing soil penetration. It is important to arrive at the setting illustrated above so further tooling adjustments will be uniform.



### **⚠️ ROW UNIT DOWN PRESSURE**



**AVOID CRUSHING.** Make sure all personnel are clear of the implement. Lower implement to the ground, place tractor in park, turn off engine, and remove key.

**USE BAR STANDS TO SUPPORT THE IMPLEMENT.** Park implement on a clean, dry, and level surface. An uneven surface could cause implement to shift or fall, resulting in personal injury or death, as well as implement damage. Securely support all implement components that must be raised. Remove buildup of grease, oil, or debris prior to adjusting.

Two adjustable down pressure springs supply row unit down pressure to assist with row unit tooling soil penetration. After toolbar height and orientation is set, row unit down pressure can be adjusted.

Down pressure springs should be adjusted so that parallel linkages operate independent of the toolbar and the toolbar serves as a towing device. Compacted soil conditions may require an increase in down pressure and softer soil conditions may require a decrease in down pressure to provide adequate soil penetration across the implement.

If a rigid toolbar is used with 8385 PL Bedder row units, down pressure adjustment between row units typically varies slightly. If a folding toolbar is used, wing sections tend to float upward, unless mechanically restrained. (refer to toolbar operator's manual) Wing row units, not mechanically restrained, may require a decreased amount of down pressure to allow row units to perform consistently across the implement.

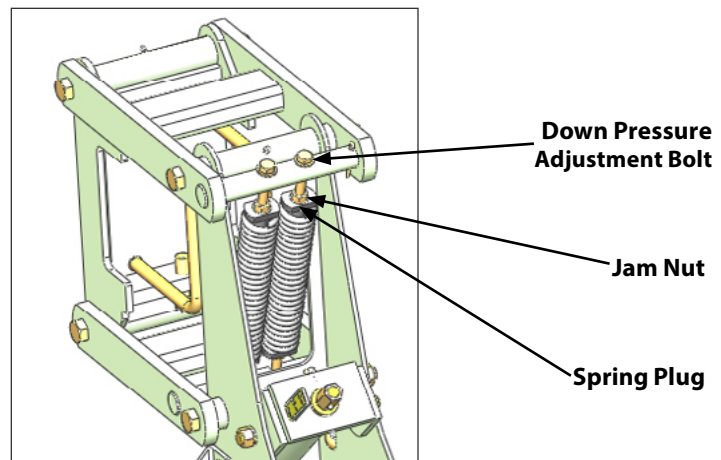

**NOTE:** RECOMMENDED TOOLS: DOWN PRESSURE ADJUSTMENT BOLT AND JAM NUT - 3/4 END WRENCH, SPRING PLUG - 1 1/4 END WRENCH.

**NOTE:** ADJUST ALL FOUR DOWN PRESSURE SPRINGS PER ROW UNIT EVENLY.



1. Loosen jam nut from spring plug.
2. Adjust down pressure adjustment bolt.  
(clockwise - increase pressure, counterclockwise - decrease pressure)
3. Tighten jam nut against spring plug to torque specifications.

**NOTE:** TOO MUCH DOWN PRESSURE APPLIED TO THE INDIVIDUAL ROW UNITS CAN ESSENTIALLY LIFT THE TOOLBAR TO AN UNDESIREABLE OPERATING HEIGHT. LIFTING THE TOOLBAR WILL CAUSE THE PARALLEL LINKAGES TO "BOTTOM OUT" AND THE ROW UNITS WILL NOT OPERATE INDEPENDENT OF THE TOOLBAR RESULTING IN NON-UNIFORM TILLAGE ACROSS THE IMPLEMENT.

### ROW UNIT DEPTH ADJUSTMENT



Row unit depth is governed by the vertical position of the depth band coulter. When the depth band coulter is adjusted upward, this allows for deeper row unit tillage, and vice versa when the depth band coulter is adjusted downward. Adjust the depth band coulter by rotating the adjustment rod illustrated below, using the provided adjustment crank located on the front of the outer row unit on the machine.

**AVOID CRUSHING.** Make sure all personnel are clear of the implement. Lower implement to the ground, place tractor in park, turn off engine, and remove key.

**USE BAR STANDS TO SUPPORT THE IMPLEMENT.** Park implement on a clean, dry, and level surface. An uneven surface could cause implement to shift or fall, resulting in injury or death, as well as implement damage. Securely support all implement components that must be raised. Remove buildup of grease, oil, or debris prior to adjusting the trash opener assembly.

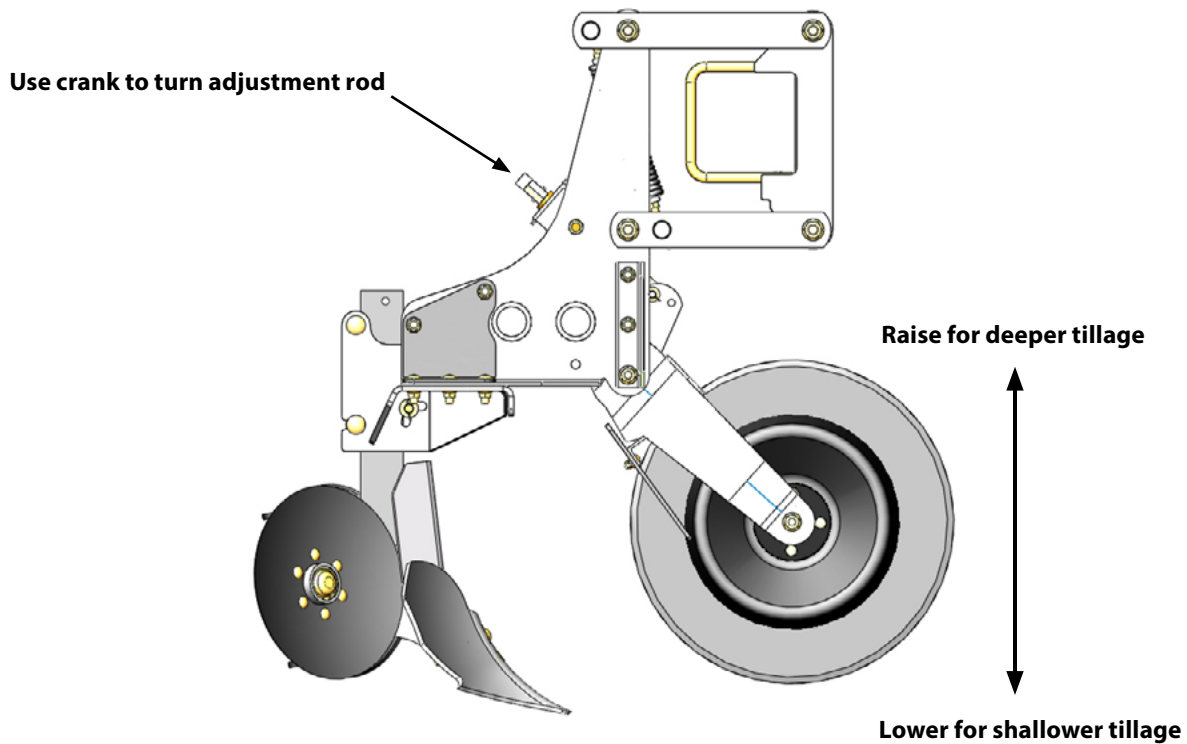

### LISTING DISC ADJUSTMENT



The listing discs of the 8385 PL Bedder are adjustable in two ways; disc width and disc aggression. The listing discs may be adjusted outward to create narrower beds, and vice versa to create wider beds. The disc aggression may be adjusted to create taller beds, and vice versa to create shorter beds. A more aggressive adjustment (discs rotated outward) creates a taller bed. Refer to the illustrations below for instructions on adjusting the listing discs.

**AVOID CRUSHING.** Make sure all personnel are clear of the implement. Lower implement to the ground, place tractor in park, turn off engine, and remove key.

**USE BAR STANDS TO SUPPORT THE IMPLEMENT.** Park implement on a clean, dry, and level surface. An uneven surface could cause implement to shift or fall, resulting in injury or death, as well as implement damage. Securely support all implement components that must be raised. Remove buildup of grease, oil, or debris prior to adjusting the row cleaner assembly.

**DISC WIDTH ADJUSTMENT**

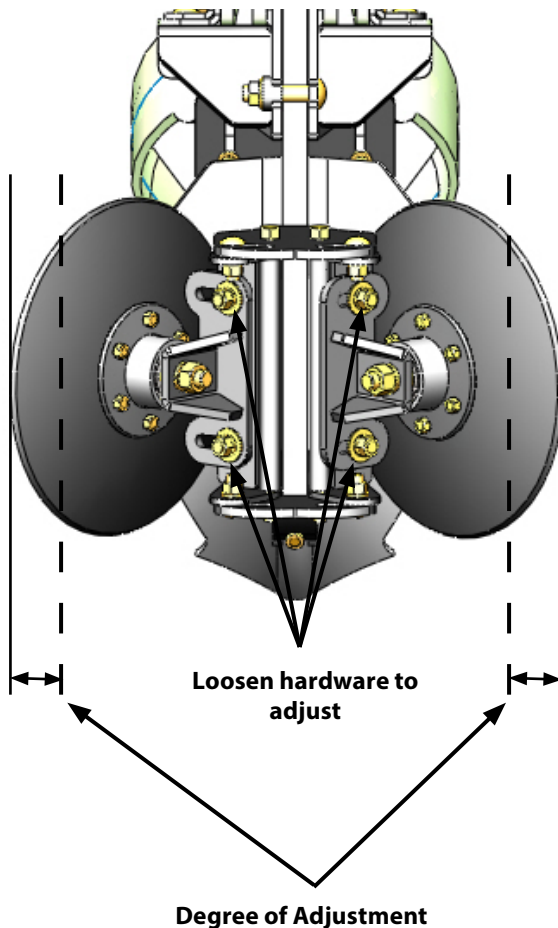

**DISC AGGRESSION ADJUSTMENT**

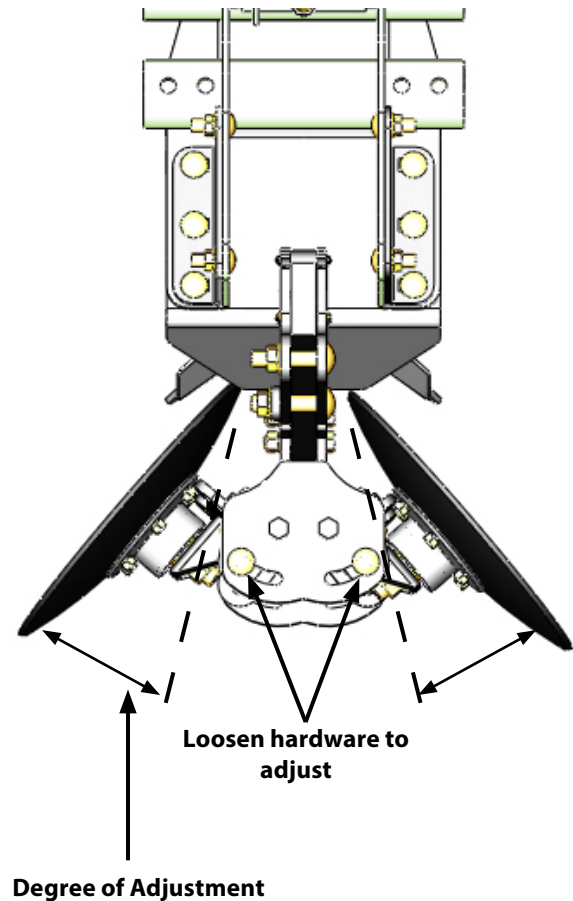





**AVOID CRUSHING.** Make sure all personnel are clear of the implement. Lower implement to the ground, place tractor in park, turn off engine, and remove key.

**USE BAR STANDS TO SUPPORT THE IMPLEMENT.** Park implement on a clean, dry, and level surface. An uneven surface could cause implement to shift or fall, resulting in injury or death, as well as implement damage. Securely support all implement components that must be raised. Remove buildup of grease, oil, or debris prior to adjusting implement.

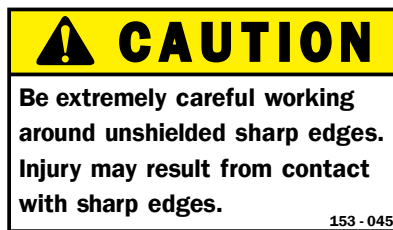

### **PROBLEM:**

Row unit tooling does not penetrate soil. Wing row units float upward.

### **SOLUTION OPTIONS:**

1. Make sure when in the field position, correct toolbar height and orientation is achieved. Use tractor lower hitch stop, lift assist wheels, and/or toolbar gauge wheels, if equipped, to set field position toolbar height and orientation.
2. Adjust row unit down pressure springs to arrive at a setting where parallel linkages operate independent of the toolbar and the toolbar serves as a towing device.

**NOTE:** TOO MUCH DOWN PRESSURE APPLIED TO THE INDIVIDUAL ROW UNITS CAN ESSENTIALLY LIFT THE TOOLBAR TO AN UNDESIREABLE OPERATING HEIGHT. LIFTING THE TOOLBAR WILL CAUSE THE PARALLEL LINKAGES TO "BOTTOM OUT" AND THE ROW UNITS WILL NOT OPERATE INDEPENDENT OF THE TOOLBAR RESULTING IN NON-UNIFORM TILLAGE ACROSS THE IMPLEMENT.

3. If a rigid toolbar is used with 8385 PL Bedder row units, down pressure adjustment between row units typically varies slightly. If a folding or stacking toolbar is used, wing sections tend to float upward, unless mechanically restrained. (refer to toolbar operator's manual) Wing row units, not mechanically restrained, may require a decreased amount of down pressure to allow row units for perform consistently across the implement.



**⚠ PRACTICE SAFE MAINTENANCE**

Proper maintenance is your responsibility. Maintenance neglect and/or poor maintenance practices can result in injury or death. Always use the proper tools to maintain implement.

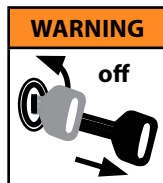

**AVOID CRUSHING.**

Make sure all personnel are clear of the implement. Lower implement to the ground, place tractor in park, turn off engine, and remove key.



**USE BAR STANDS AND CYLINDER STOPS TO SUPPORT THE IMPLEMENT.** Park implement on a clean, dry, and level surface. An uneven surface could cause implement to shift or fall, resulting in injury or death, as well as implement damage. Securely support all implement components that must be raised. Remove buildup of grease, oil, or debris prior to maintaining implement.



**AVOID ENTANGLEMENT.** Never lubricate or service implement in motion. Keep away from power driven parts when in motion. Disengage power sources prior to maintaining implement. Injury or death can result from contact with power driven parts when in motion.



**AVOID CRUSHING.** Do not stand between the tractor and implement when connecting or disconnecting implement. Injury or death can result from being trapped between the tractor and implement.



Escaping pressurized hydraulic fluid can penetrate skin, resulting in injury or death. Relieve hydraulic system pressure before connecting or disconnecting tractor. Use cardboard or wood, NOT BODY PARTS, to check for suspected hydraulic leaks. Wear protective gloves and safety glasses or goggles when working with hydraulic systems. If an accident occurs, see a doctor immediately for proper treatment.

## TORQUE SPECIFICATIONS

Unified Inch Bolt and Screw Torque Values

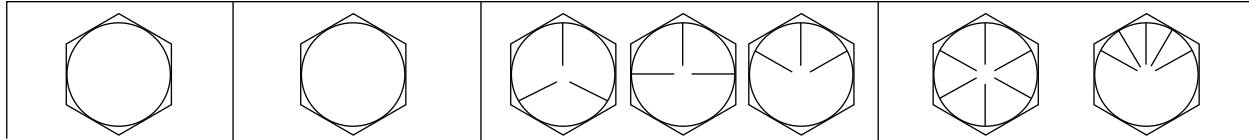

Bolt or Screw Size	SAE Grade 1				SAE Grade 2 <sup>a</sup>				SAE Grade 5, 5.1 or 5.2				SAE Grade 8 or 8.2			
	Lubricated <sup>b</sup>		Dry <sup>c</sup>		Lubricated <sup>b</sup>		Dry <sup>c</sup>		Lubricated <sup>b</sup>		Dry <sup>c</sup>		Lubricated <sup>b</sup>		Dry <sup>c</sup>	
	N•m	lb-in	N•m	lb-in	N•m	lb-in	N•m	lb-in	N•m	lb-in	N•m	lb-in	N•m	lb-in	N•m	lb-in
1/4	3.7	33	4.7	42	6	53	7.5	66	9.5	84	12	106	13.5	120	17	150
													N•m	lb-ft	N•m	lb-ft
5/16	7.7	68	9.8	86	12	106	15.5	137	19.5	172	25	221	28	20.5	35	26
									N•m	lb-ft	N•m	lb-ft				
3/8	13.5	120	17.5	155	22	194	27	240	35	26	44	32.5	49	36	63	46
			N•m	lb-ft	N•m	lb-ft	N•m	lb-ft								
7/16	22	194	28	20.5	35	26	44	32.5	56	41	70	52	80	59	100	74
	N•m	lb-ft														
1/2	34	25	42	31	53	39	67	49	85	63	110	80	120	88	155	115
9/16	48	35.5	60	45	76	56	95	70	125	92	155	115	175	130	220	165
5/8	67	49	85	63	105	77	135	100	170	125	215	160	240	175	308	225
3/4	120	88	150	110	190	140	240	175	300	220	380	280	425	315	540	400
7/8	190	140	240	175	190	140	240	175	490	360	615	455	690	510	870	640
1	285	210	360	265	285	210	360	265	730	540	920	680	1030	760	1300	960
1-1/8	400	300	510	375	400	300	510	375	910	670	1150	850	1450	1075	1850	1350
1-1/4	570	420	725	535	570	420	725	535	1280	945	1630	1200	2050	1500	2600	1920
1-3/8	750	550	950	700	750	550	950	700	1700	1250	2140	1580	2700	2000	3400	2500
1-1/2	990	730	1250	930	990	730	1250	930	2250	1650	2850	2100	3600	2650	4550	3350

Torque values listed are for general use only, based on the strength of the bolt or screw. DO NOT use these values if a different torque value or tightening procedure is given for a specific application. For plastic insert or crimped steel type lock nuts, for stainless steel fasteners, or for nuts on U-bolts, see the tightening instructions for the specific application. Shear bolts are designed to fail under predetermined loads. Always replace shear bolts with identical grade.

Replace fasteners with the same or higher grade. If higher grade fasteners are used, tighten these to the strength of the original. Make sure fastener threads are clean and that you properly start thread engagement. When possible, lubricate plain or zinc plated fasteners other than lock nuts, wheel bolts or wheel nuts, unless different instructions are given for the specific application.

<sup>a</sup> Grade 2 applies for hex cap screws (not hex bolts) up to 6 in. (152 mm) long. Grade 1 applies for hex cap screws over 6 in. (152 mm) long, and for all other types of bolts and screws of any length.

<sup>b</sup> "Lubricated" means coated with a lubricant such as engine oil, fasteners with phosphate and oil coatings, or 7/8 in. and larger fasteners with JDM F13C zinc flake coating.

<sup>c</sup> "Dry" means plain or zinc plated without any lubrication, or 1/4 to 3/4 in. fasteners with JDM F13B zinc flake coating.





### LUBRICATION

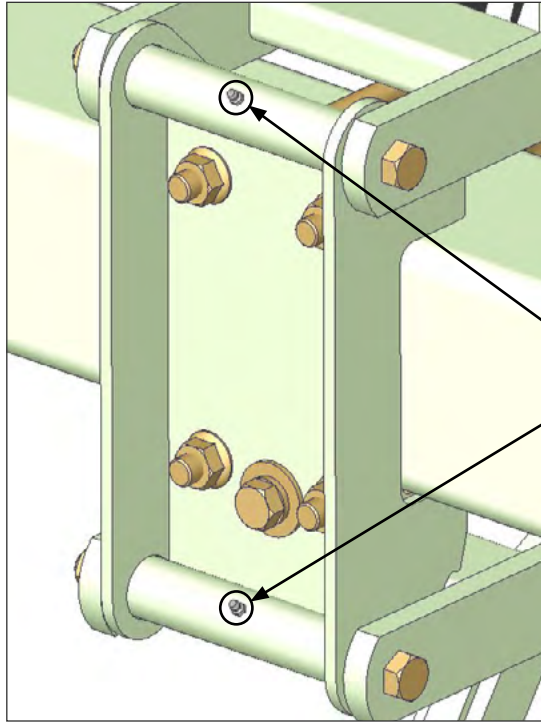

GREASE  
10 

- Grease - use high quality multi-purpose grease.
- Follow recommended service interval illustrated below.

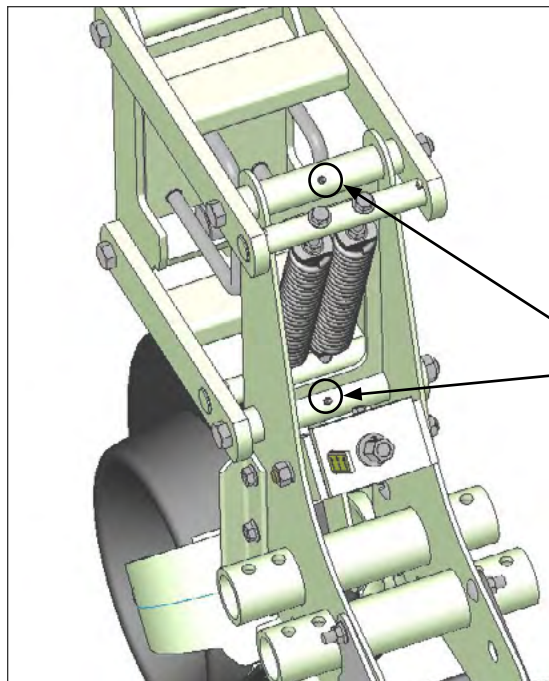

  
10   
Front parallel linkage  
bushings



  
10   
Rear parallel linkage  
bushings

### LUBRICATION



- Grease - use high quality multi-purpose grease.
- Follow recommended service interval illustrated below.

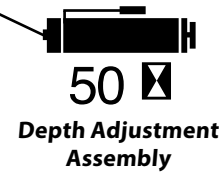
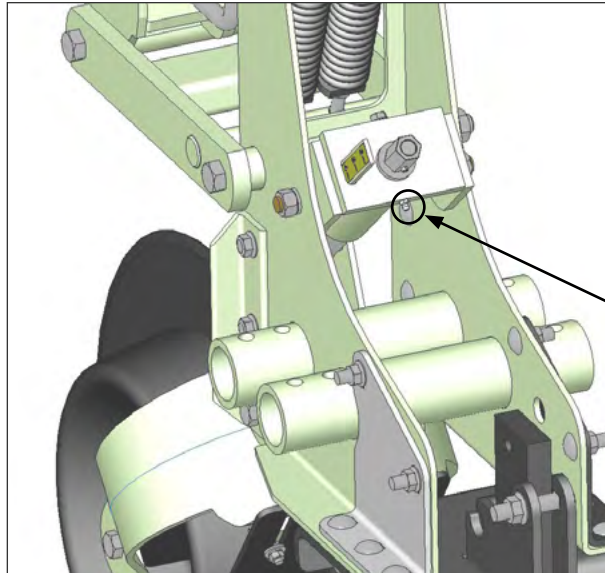

### IMPLEMENT INSPECTION



- When replacement parts are necessary for periodic maintenance and servicing, genuine factory replacement parts must be used to restore implement to original specifications. Replace broken or worn parts immediately. Contact your Orthman dealer for replacement parts.

- During break-in (40 hours), check hardware for proper torque every 10 to 20 hours.



- Before each use, check hardware for wear and proper torque. Replace damaged or missing hardware with hardware of an identical grade to restore implement to original specifications.

- Do not allow debris to buildup on any surface of the implement.

- Replace all shields and guards. Be sure all tools, parts, and service equipment are removed prior to transporting equipment.

## **IMPLEMENT STORAGE**

- Clean and touch up paint seasonally to avoid corrosion and rust. Contact your Orthman dealer for touch up paint.
- Inspect all safety and Orthman decals and replace if missing or damaged. Contact your Orthman dealer for replacement decals.
- Grease all zerks regardless of hourly interval prior to storage.
- Check all hardware according to torque specifications prior to storage.
- Replace all worn or damaged parts prior to storage.
- Store inside if possible. Storing implement inside will prolong the life of the components.



- AVOID CRUSHING.** Make sure all personnel are clear of the implement. Lower implement to the ground, place tractor in park, turn off engine, and remove key.

Storing implement on the ground will relieve the tractor three point hitch of hydraulic pressure.

Hydraulic systems tend to settle, endangering anything underneath the implement.



**USE BAR STANDS TO SUPPORT THE IMPLEMENT.** Store implement on a clean, dry, and level surface. An uneven surface could cause implement to shift or fall, resulting in injury or death, as well as implement damage. Securely support all implement components that must be raised. Store implement away from human activity.



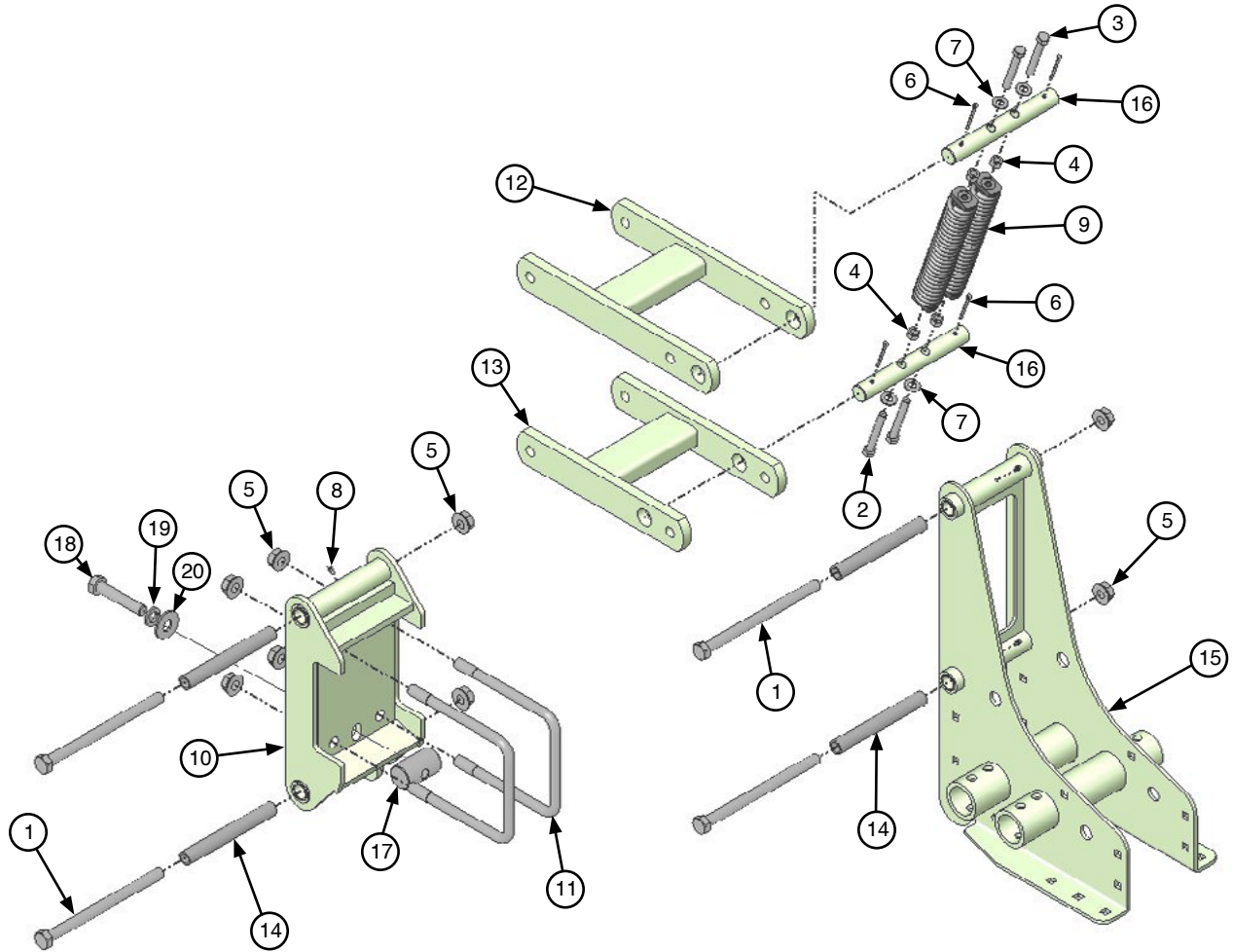

### MOUNT AND PARALLEL LINKAGE ASSEMBLY

Key	Part #	Description	Qty	Notes
1	100-176	Bolt	4	3/4" x 10 1/2" GR. 8
2	100-220	Bolt	2	1/2" x 3 3/4"
3	100-288	Bolt	2	1/2" x 3 1/2"
4	102-007	Nut	2	1/2"
5	102-121	Lock Nut	4	3/4"; Flanged
6	104-030	Cotter pin	4	----
7	108-001	Flat washer	4	1/2"
8	110-001	Grease fitting	4	1/4"
9	311-401	Spring assembly	2	----
10	387-525	Mounting bracket	1	Includes items 14 & 8

Key	Part #	Description	Qty	Notes
11	315-031	U-bolt	2	3/4" - 7"x7" bars
12	385-093	Linkage	1	Top
13	385-095	Linkage	1	Bottom
14	385-140	Bushing	4	----
15	385-358	Main Frame	1	Includes items 14 and 8
16	385-360	Trunion shaft	2	----
17	387-521	Wedge	1	----
18	100-490	Bolt	1	3/4" x 4"
19	108-022	Lock washer	1	3/4"
20	108-011	Flat washer	1	3/4"

## PARTS IDENTIFICATION

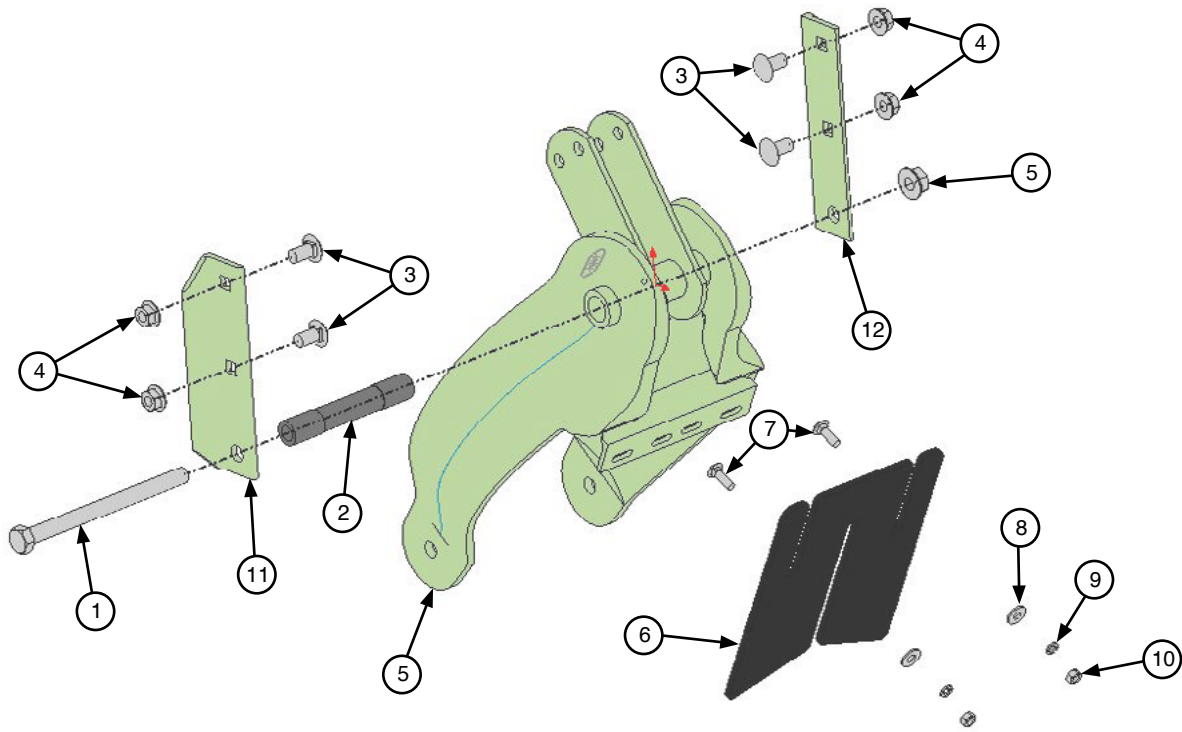

### COULTERS FORK ASSEMBLY

Key	Part #	Description	Qty	Notes
1	100-147	Bolt	1	5/8" x 7 1/2"; GR. 5
2	385-132	Bushing	1	----
3	100-054	Carriage Bolt	4	1/2" x 1"; GR. 5
4	102-112	Nut	4	1/2"; Flanged
5	102-104	Nut	1	5/8"; Flanged
6	385-168	Scraper	1	----
7	100-003	Carriage Bolt	2	5/16" x 1"; GR. 5
8	108-006	Flat washer	2	5/16"
9	108-017	Lock washer	2	5/16"
10	102-004	Nut	2	5/16"
11	385-327	Fork Brace	1	LH
12	385-326	Fork Brace	1	RH

# 8385

**BEDDING ATTACHMENT ASSEMBLY**

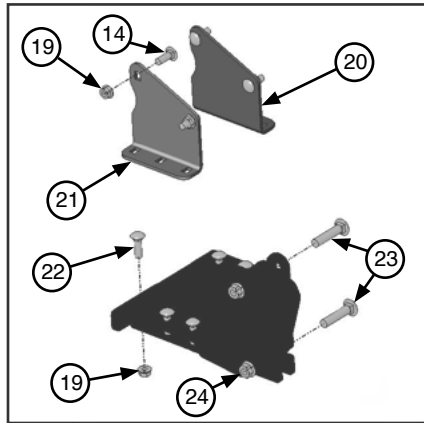

**ACCESSORY CLAMP**

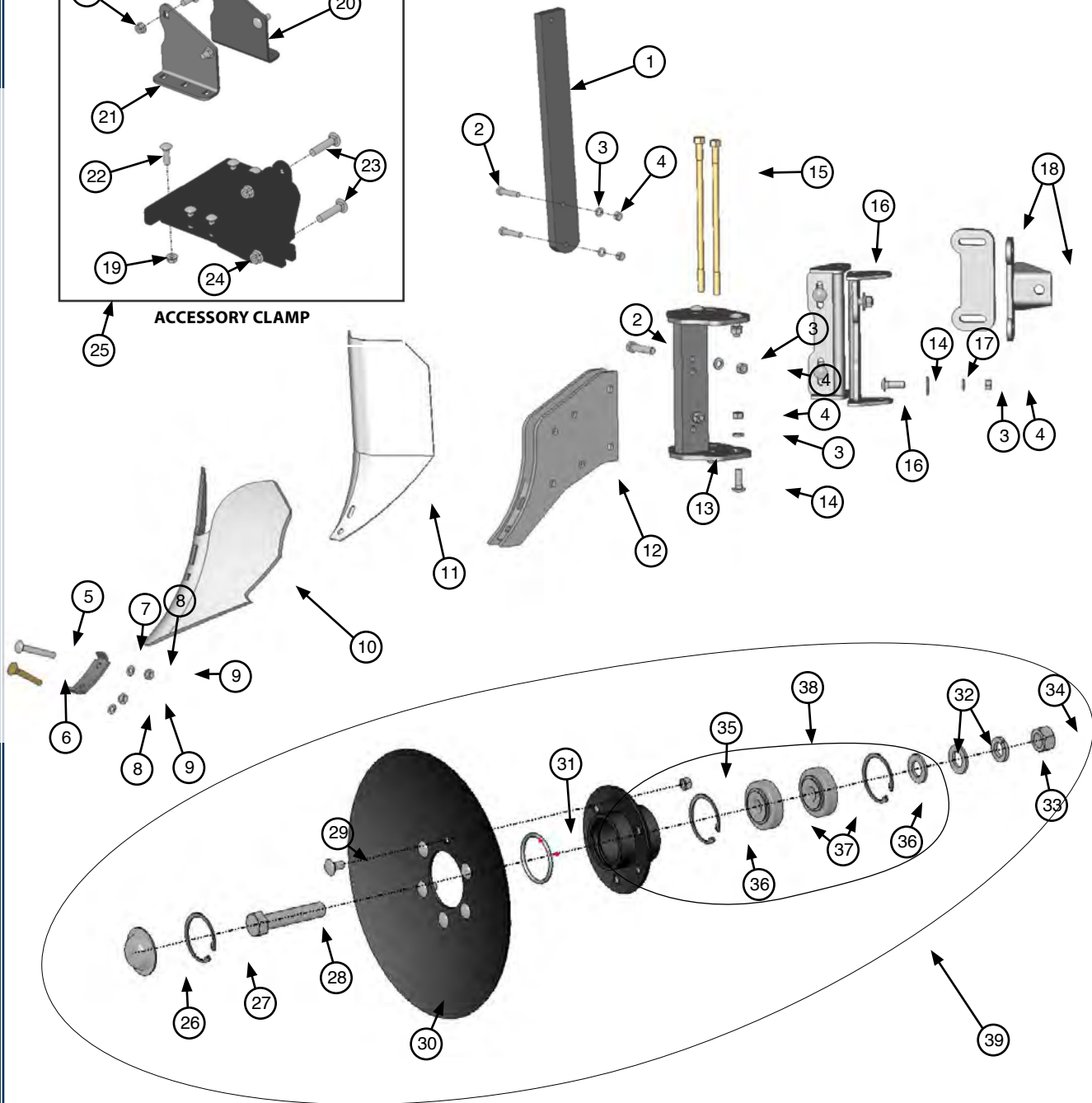

*Parts list located on the following page.*

**PARTS IDENTIFICATION**
**BEDDING ATTACHMENT ASSEMBLY**

Key	Part #	Description	Qty	Notes	Key	Part #	Description	Qty	Notes
1	311-024	Shank	1	1" x 3" x 24"	21	385-203	LH Saddle	1	----
2	100-120	Bolt	4	1/2" x 2 1/2"; GR. 5	22	100-014	Carriage bolt	6	1/2" x 1 3/4"; GR. 5
3	108-020	Lock washer	12	1/2"	23	100-026	Carriage bolt	2	5/8" x 3"; GR. 5
4	102-007	Nut	12	1/2"	24	102-108	Nut	2	5/8"; Flanged
5	100-011	Carriage bolt	1	7/16" x 1 1/2"; GR. 5	25	602-654	Shank clamp asmbly.	1	Includes items 14, & 19-24
6	100-402	Plow bolt	1	7/16" x 3"; GR. 5	26	319-126	Dust cap	1	----
7	311-008	Heel plate	1	----	27	104-105	Snap ring	1	2 3/8"
8	108-019	Lock washer	2	7/16"	28	100-202	Bolt	1	3/4" x 3 3/4"; GR. 5
9	102-006	Nut	2	7/16"	29	100-008	Carriage bolt	6	3/8" x 3/4"; GR. 5
10	162-008	Shovel	1	8"	30	166-005	Listing Disc	1	14"
	162-009	Shovel	1	10"	31	150-018	O-ring	1	----
11	308-308	Residue shield	1	----	32	108-003	Flat washer	2	3/4"
12	308-300	Foot piece asmbly	1	Includes item 7 & HW	33	108-022	Lock washer	1	3/4"
13	308-284	Mount	1	----	34	102-009	Nut	1	3/4"
14	100-013	Carriage bolt	8	1/2" x 1 1/2"; GR. 5	35	102-027	Lock nut	6	3/8"
15	308-291	Shaft bolt	2	1/2" x 12"	36	104-105	Snap ring	2	2 3/8"
16	308-295	Mounting bracket	2	----	37	120-070	Bearing	2	----
17	108-009	Flat washer	4	1/2"	38	312-320	Hub assembly	1	Includes items 36 & 37
18	308-280	Mounting bracket	2	----	39	601-192	Disc assembly	1	Includes items 26-39
19	102-109	Nut	10	1/2"; Flanged	-	-	-	-	-
20	385-202	RH Saddle	1	----	-	-	-	-	-



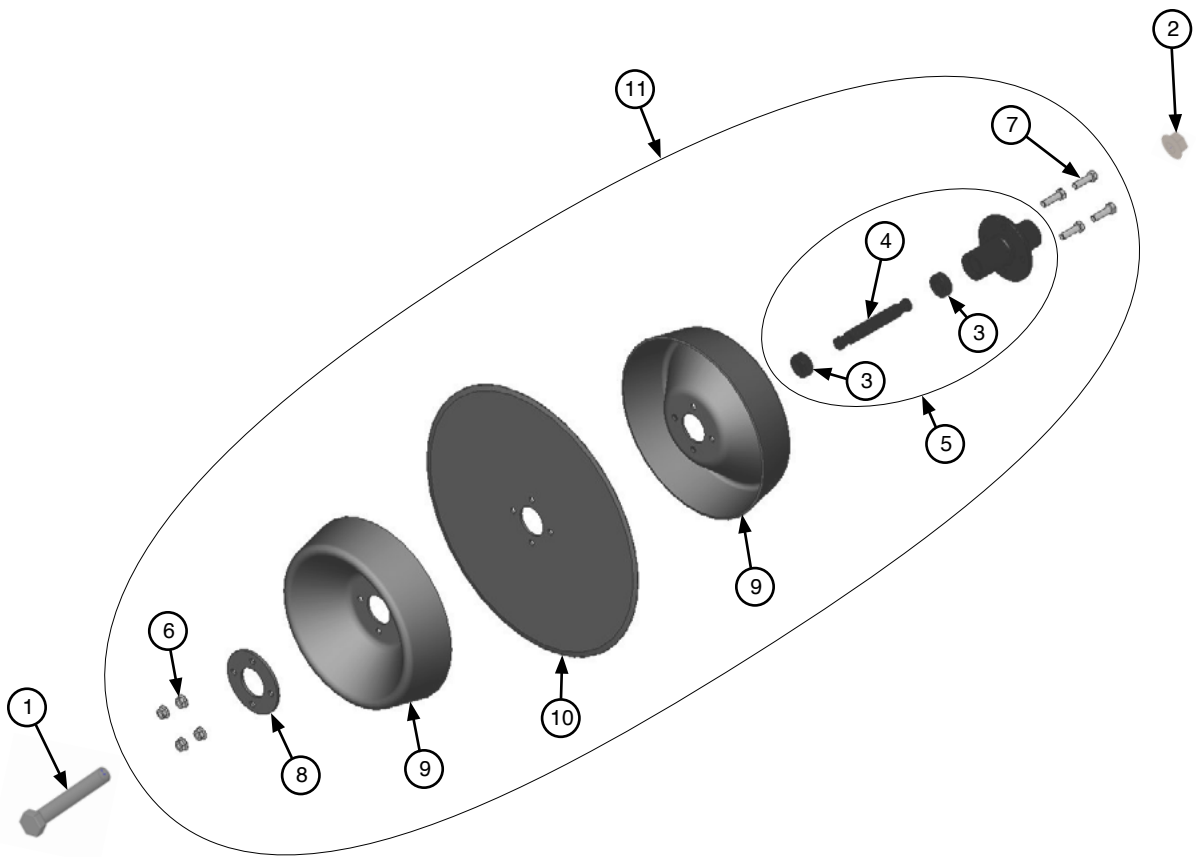

**DEPTH BAND COULTER ASSEMBLY**

Key	Part #	Description	Qty	Notes
1	100-150	Bolt	1	5/8" x 9"; GR. 5
2	102-121	Lock nut	1	5/8"
3	315-261	Bearing	2	----
4	315-123	Bearing spacer	1	----
5	312-132M	Hub assembly	1	Includes items 3, 4, and hub
6	102-119	Lock Nut	4	1/2"; Flanged
7	100-117	Bolt	4	1/2" x 1 3/4"; GR. 5
8	312-131	Depth band washer	1	----
9	385-167	Depth Band	2	----
10	166-033	Smooth Disc	1	22"
11	635-027	Depth band coultter assembly	1	Includes items 3-10

