



905 SERIES TOOLBAR

Operator's Manual

**ORTHMAN
MANUFACTURING
INCORPORATED**

STILL THE STRONGEST

**ORTHMAN MFG. INC.
75765 RD. 435
LEXINGTON, NE 68850**

OM08-03-01

905 SERIES TOOLBAR

The new Orthman 905 Series Stacking Toolbars are an engineering update to the classic 900 Stacker Bar. Orthman Stacking Toolbars will continue to outshine the competition. The redesign engineering of the 905 Stacker includes many features such as a universal gull wing kit.

Toolbars are constructed of solid 7" x 7" x 3/8" wall tube and 5" x 24" wing fold cylinders to provide producers with years of hassle free use. The 905 Series Toolbars are available in size configurations up to 16 row 30".

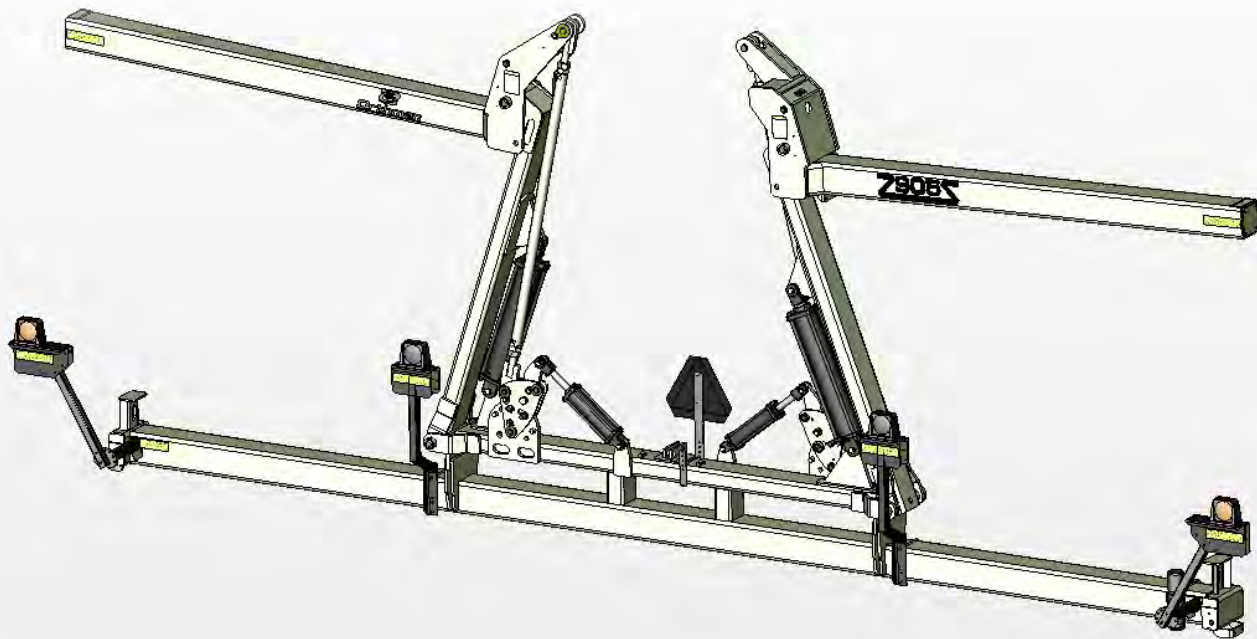

This manual is considered to be an integral component of the 905 Series Toolbar and is designed to educate the owner and operators regarding safety, operation, maintenance, troubleshooting, and component identification.

All personnel involved in the operation of the 905 Series Toolbar are responsible for reading and understanding the entire contents of this manual. This manual is designed to keep the operator safe and knowledgeable as well as prolong the life of the implement, minimize downtime, and maximize field efficiency. This manual should accompany the implement if it is ever to be sold.

We would like to thank you for placing your confidence in Orthman Mfg., Inc. Your 905 Series Toolbar is manufactured to meet the highest standards and is built with Orthman precision and strength to increase your agricultural operation's dependability and profitability.

Thank you for choosing Orthman.

STILL THE STRONGEST

WARRANTY

Orthman Mfg., Inc. warrants the whole goods products it manufactures to be free from defects in material or workmanship for a period of one (1) year from the date of sale of the product(s) to the original user. Products not manufactured, but supplied by Orthman Mfg., Inc. on Orthman products, are subject to, conform with, and are limited to the warranty of our suppliers.

Orthman Mfg., Inc. warrants the parts it manufactures to be free from defects in material or workmanship for a period of ninety (90) days from the date of delivery of the product(s) to the original user. Products not manufactured, but supplied by Orthman Mfg., Inc. on Orthman products, are subject to, conform with, and are limited to the warranty of our suppliers.

Warranty of Orthman whole goods and/or parts applies only to material and workmanship. Misuse, misapplication, neglect, alteration, accident, normal wear, or acts of God affecting Orthman products are not eligible for warranty.

Warranty of serial numbered goods will only be considered if the product has a completed Warranty Registration on file at Orthman. This Warranty Registration must be completed and returned to Orthman within thirty (30) days of the sale of the product(s) to the original user. *No serial numbered goods or related parts and/or labor will be warranted without a Warranty Registration on file.* Warranty issues falling within the first thirty days of a product's use will be handled at the discretion of Orthman. Warranty of parts will not require a Warranty Registration, but proof of date of delivery of the product to the original customer must be provided.

WARRANTY CLAIMS: A warranty claim and request to return defective product(s) must be presented to the Orthman Service Department by the selling dealer describing the defect in material or workmanship of an Orthman product(s) within ten (10) days of its discovery. This claim may be made via phone, e-mail, fax, or written request. Claims for warranty of serial numbered goods must include the Orthman product serial number and model number. Claims for warranty of parts will not require a product serial number or model number, but must be identified by an Orthman part number. Claims for warranty of whole goods or parts must also include proof of date of sale of the product to the original customer by an Orthman dealer.

The Orthman Service Department will proceed in making a preliminary decision as to the eligibility of the claim for warranty consideration. After the Orthman Service Department deems it necessary to proceed with warranty consideration, a Return Goods Authorization (RGA) will be completed by the Orthman Service Department in conjunction with the selling dealer. Upon completion of the RGA, the defective product(s) must be returned to Orthman to ensure warranty consideration. Defective product(s) must be returned to Orthman by either the selling dealer or the customer. Customer delivery of defective product(s) must be approved by Orthman and the selling dealer prior to delivery. The defective product(s) in question must be sent, freight prepaid, within sixty (60) days of the discovery of the product(s) failure and initial warranty claim. Replacement product(s) may be sent to the selling dealer, directly to the customer, or picked up at the Orthman facility. Replacement product(s), sent directly to the customer or picked up must be approved by Orthman and the selling dealer. At the discretion of the Orthman Service Department, replacement product(s) may be sent prior to, or after, the Orthman Service Department receives the defective product(s).

Any variation in the above procedure is at the sole discretion of the Orthman Service Department.

No products will be accepted at Orthman without all proper paperwork completed including Warranty Registration and RGA(s).

Parts returned to Orthman without proper authorization will be returned to the sender at the sender's expense.

Orthman agrees to handle all warranty claims in a timely manner and will inform dealers of any revisions or modifications to the Orthman Warranty Policy. Eligible warranty claims will be processed by Orthman within sixty (60) days of receiving failed product(s) or a valid service or repair labor claim. Eligible warranty claims regarding returned product(s) or service and/or repair labor will be paid through a credit memo issued to the appropriate dealer's account as determined by the Orthman Service Department.

If a warranty claim is found to be ineligible for warranty coverage, the Orthman Service Department will be responsible to inform the dealer in order to determine the course of action to be taken. Orthman reserves the right to make changes in specification and design without notice and without incurring any obligations to owners of products previously sold.

© Copyright 2008
Orthman Manufacturing Inc.
Lexington, Nebraska
All rights reserved.

Orthman provides this manual without warranty of any kind, expressed or implied. This manual reflects the product at the time of publication. All information within is based upon current information on the publication date. Orthman assumes no responsibility for damages incurred due to the use of the illustrations, information, and specifications within this publication.

TABLE OF CONTENTS

INTRODUCTION

General Information-905 Series Toolbar.....	1-1
Warranty Information.....	1-2
Table of Contents.....	1-3

IMPORTANT SAFETY INFORMATION

Safety Alert Symbol-Signal Words-Shutdown and Storage.....	2-1
Your Protection - Equipment Safety - No Riders.....	2-2
Safe Transport - Warning and Safety Lights.....	2-3
Safe Operation.....	2-4
Practice Safe Maintenance.....	2-5
Practice Safe Maintenance-Prepare for Emergencies - Safety Never Hurts.....	2-6
Safety Decals-Orthman Decals.....	2-7
Safety Decals-Orthman Decals.....	2-8
Safety Lighting-Safety Decals.....	2-9

MAJOR COMPONENT IDENTIFICATION

Component Identification.....	3-1
-------------------------------	-----

PREPARATION AND SETUP

Preparing the Toolbar-Implement to Tractor Connection.....	4-1
Stacking Process.....	4-2
Safety Lighting.....	4-3
Gull Wing Kit.....	4-4
Gull Wing Hydraulic Setup.....	4-5
Semi Mounted Operation with Lift Assist Wheels.....	4-6
Hydraulic Hose Tee Package.....	4-7
Wing Coupler Kit.....	4-8

FIELD SETTINGS

Float Operation and Gull Wing Hydraulic Kit.....	5-1
Wing Float Operation-Operating Modes.....	5-2
Gull Wing Operation.....	5-5

TROUBLESHOOTING

Toolbar Height and Orientation.....	6-1
Wings Do Not Fold.....	6-2

PARTS IDENTIFICATION

Outer Hinge Assembly.....	7-1
Center Assembly.....	7-2
Stack Fold Hydraulic Assembly.....	7-3
Safety Lights Assembly.....	7-4
Safety Light Cables.....	7-5

MAINTENANCE

Practice Safe Maintenance.....	8-1
Lubrication.....	8-2
Implement Inspection - Implement Storage.....	8-3
Torque Specifications.....	8-4

SAFETY ALERT SYMBOL

The **SAFETY ALERT SYMBOL** warns of potential hazards to personal safety and that extra precautions must be taken. When you see this symbol, carefully read the message(s) that follow. Follow all recommended precautions and safe operating practices in this manual.

Hazard control and accident prevention are dependent upon the safety awareness and proper training of personnel involved in the operation of this implement.

BE AWARE OF SIGNAL WORDS

SIGNAL WORDS designate a degree or level of **HAZARD** seriousness. These signal words include:



RED

DANGER indicates a hazardous situation that, if not avoided, will result in death or serious injury. Danger is limited to extreme situations, typically for machine components which for functional purposes, cannot be guarded.



ORANGE

WARNING indicates a potentially hazardous situation that, if not avoided, could result in death or serious injury. Warning includes hazards that are exposed when safety guards are removed. Warning may also be used to alert against unsafe practices.



YELLOW

CAUTION indicates a potentially hazardous situation that, if not avoided, may result in minor or moderate injury. Caution may also be used to alert against unsafe practices.



SHUTDOWN AND STORAGE

AVOID CRUSHING. Make sure all personnel are clear of the implement. Lower implement to the ground, place tractor in park, turn off engine, and remove key.



USE BAR STANDS TO SUPPORT THE IMPLEMENT. Store implement on a clean, dry, and level surface. An uneven surface could cause implement to shift or fall, resulting in injury or death, as well as implement damage. Securely support all implement components that must be raised. Store implement away from human activity.

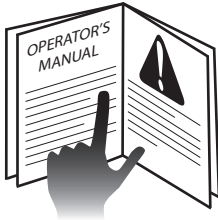

IMPORTANT SAFETY INFORMATION**FOR YOUR PROTECTION****CAUTION**

READ AND UNDERSTAND THE ENTIRE CONTENT OF THIS MANUAL BEFORE OPERATING OR SERVICING IMPLEMENT. Read and understand all operator manuals for machinery used in conjunction with the 905 Toolbar.

Carefully **READ ALL SAFETY DECALS** in this manual as well as on the implement. Keep implement clean so decals are easily visible. Keep all safety decals in good, clean, and legible condition. Immediately replace damaged and/or missing decals. Replacement decals are available from your Orthman dealer.

Learn to operate the implement and all components properly. Do not let others operate implement without proper instruction. Unauthorized implement modifications may impair function and safety. If you do not understand any content in this manual or need assistance, contact your Orthman dealer.

(Orthman Manufacturing Inc. - 75765 Rd. 435 - Lexington, NE 68850 - (308) 324-4654)

EQUIPMENT SAFETY GUIDELINES

Operator safety is the primary concern when designing an Orthman implement. Orthman integrates as many safety features into the implement as possible. The operator can avoid many hazards and possible accidents by observing precautions in this safety section.

Insist that yourself and personnel working with and around you follow all safety precautions. Be cautious when working with or around implement to avoid injury.

WARNING**NO RIDERS**

NEVER ALLOW RIDERS ON TRACTOR OR IMPLEMENT. Riders hinder operator visibility and can be thrown from the implement and/or be struck by foreign objects resulting in injury or death.

IMPORTANT SAFETY INFORMATION

SAFE TRANSPORT

 Engage transport locking devices prior to implement transport.

Plan your route to avoid traffic. Yield to traffic in all situations.

Maximum transport speed is 20 mph (32 kph). Various conditions will require reduced speeds. Travel at speeds that allow for adequate control of stopping and steering.

AVOID ELECTROCUTION. Be aware of overhead power lines. Contact or close proximity to power lines can result in injury or death. Use extreme care when operating implement near power lines.

Know implement transport height and gross weight. Avoid overhead obstructions not allowing your transport height. Do not use bridges rated below implement gross weight.

Make sure a slow moving vehicle (SMV) placard is mounted to the implement and is easily visible to all other motorists. Refer to (pg 2-8) for SMV installation instructions.

Make allowances for implement size when transporting. Sudden braking can cause a towed load to swerve and/or rollover. Never use independent braking with implement in tow as loss of control and/or rollover can result. Reduce speed if towed implement is not equipped with brakes.

Do not coast. Always keep tractor or towing device in gear to provide engine braking when traveling downhill.



SMV



 **WARNING AND SAFETY LIGHTS**

Oversized implements and slow moving vehicles create a hazard when transported on public roads.

Make sure all warning, safety lights, and turning signals are working and clean. Use safety lighting when using public roads day and night. Replace missing or damaged lights immediately. Comply with state and local laws governing implement safety lighting.

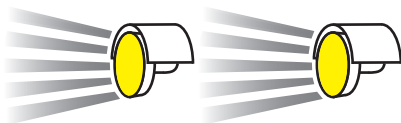

A safety lighting package, conforming to implement lighting standard ANSI/ASAE S279.12, is available for addition to the 905 Series Toolbar. Contact your Orthman dealer for safety lighting package information. Refer to toolbar operator's manual for safety lighting package installation and adjustment.

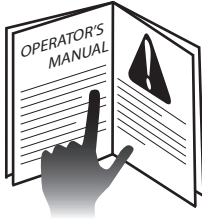
IMPORTANT SAFETY INFORMATION**SAFE OPERATION****CAUTION**

- ⚠ READ AND UNDERSTAND THE ENTIRE CONTENT OF THIS MANUAL BEFORE OPERATING OR SERVICING IMPLEMENT.** Implement is to be operated by qualified personnel only. Never let children operate implement. A complete understanding of safety precautions, operation, and maintenance is mandatory before implement use.

DANGER

AVOID ELECTROCUTION. Be aware of overhead power lines. Contact or close proximity to power lines can result in injury or death. Use extreme care when operating implement near power lines.

Know implement transport height and gross weight. Avoid overhead obstructions not allowing your transport height. Do not use bridges rated below your gross weight.

DANGER

AVOID ROLLOVER. Do not fold or unfold implement and avoid sharp turns when on a hillside, as shift of weight could cause rollover. Operate implement at a safe distance from terrain irregularities and other obstructions that could cause rollover.

WARNING

AVOID CRUSHING. Make sure all personnel are clear of implement at all times implement is in motion. Be aware of obstructions above, below, and around implement when in operation or transport. Injury or death can result from being struck by the implement.

IMPORTANT SAFETY INFORMATION

⚠ PRACTICE SAFE MAINTENANCE

Proper maintenance is your responsibility. Maintenance neglect and/or poor maintenance practices can result in injury or death. Always use the proper tools to maintain implement.

AVOID CRUSHING. Make sure all personnel are clear of the implement. Lower implement to the ground, place tractor in park, turn off engine, and remove key.



USE BAR STANDS TO SUPPORT THE IMPLEMENT. Store implement on a clean, dry, and level surface. An uneven surface could cause implement to shift or fall, resulting in injury or death, as well as implement damage. Securely support all implement components that must be raised. Store implement away from human activity.



AVOID ENTANGLEMENT. Never lubricate or service implement in motion. Keep away from power driven parts when in motion. Disengage power sources prior to maintaining implement. Injury or death can result from contact with power driven parts when in motion.



AVOID CRUSHING. Do not stand between the tractor and implement when connecting or disconnecting implement. Injury or death can result from being trapped between the tractor and implement.

	<p>⚠ DANGER HIGH-PRESSURE FLUID HAZARD To prevent serious injury or death:</p> <ul style="list-style-type: none"> • Relieve pressure on hydraulic system before servicing or disconnecting hoses. • Wear proper hand and eye protection when searching for leaks. Use wood or cardboard instead of hands. • Keep all components in good repair. <p style="text-align: right; font-size: small;">153-628</p>

Escaping pressurized hydraulic fluid can penetrate skin, resulting in injury or death. Relieve hydraulic system pressure before connecting or disconnecting tractor. Use cardboard or wood, **NOT BODY PARTS**, to check for suspected hydraulic leaks. Wear protective gloves and safety glasses or goggles when working with hydraulic systems. If an accident occurs, see a doctor immediately for proper treatment.

IMPORTANT SAFETY INFORMATION



⚠ PRACTICE SAFE MAINTENANCE

Never operate a combustion engine in an enclosed area. Make sure there is adequate ventilation. Exhaust fumes can cause asphyxiation.



Be extremely careful working around unshielded sharp edges. Injury may result from contact with sharp edges.

Keep all parts in good condition and properly installed. Replace damaged or missing parts immediately.

Remove tools and unused parts prior to implement operation.



⚠ PREPARE FOR EMERGENCIES

Be prepared for a fire. Keep a readily accessible fire extinguisher at all times.

Keep a readily accessible stocked first aid kit and emergency phone numbers for your doctor, hospital, ambulance, and fire department.

Wear protective clothing and equipment. Wear clothing appropriate for the situation. Protect your eyes, ears, hands, and feet with the use of protective goggles, ear plugs, gloves, boots, etc.

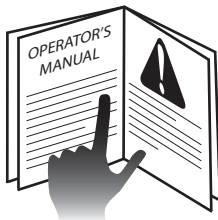

⚠ SAFETY NEVER HURTS

READ AND UNDERSTAND THE ENTIRE CONTENT OF THIS MANUAL BEFORE OPERATING OR SERVICING IMPLEMENT.

Understand all implement functions.

Never stand between tractor and implement when connecting or disconnecting implement.

Be aware of all surroundings before moving implement.

Operate implement from operator's seat only.

Never mount or dismount a moving tractor.

Never leave engine running when implement is unattended.

Keep away from power driven parts when in motion.

Make sure all personnel are clear before lowering implement to the ground.

IMPORTANT SAFETY INFORMATION

SAFETY DECALS

 Safety decals promote awareness and knowledge concerning safe operation and maintenance of the implement.

DANGER

WARNING

CAUTION

Carefully **READ ALL DECALS** in this manual as well as on the implement. Keep implement clean so safety decals are easily visible. Keep all decals in good and legible condition.

Immediately replace damaged or missing decals. Replacement decals are available from your Orthman dealer.

To install decals: Thoroughly clean area where decal is to be placed and attach decal void of bubbles. Refer to this safety information section for proper decal placement.

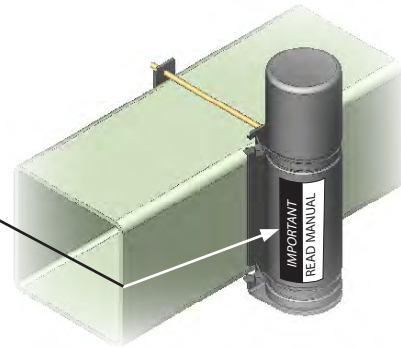

ORTHMAN DECALS

The Orthman serial tag contains valuable information. The model and serial numbers provide Orthman dealers and the Orthman Service Department with exact specifications of your implement if any warranty or service issues need to be addressed.



153-000

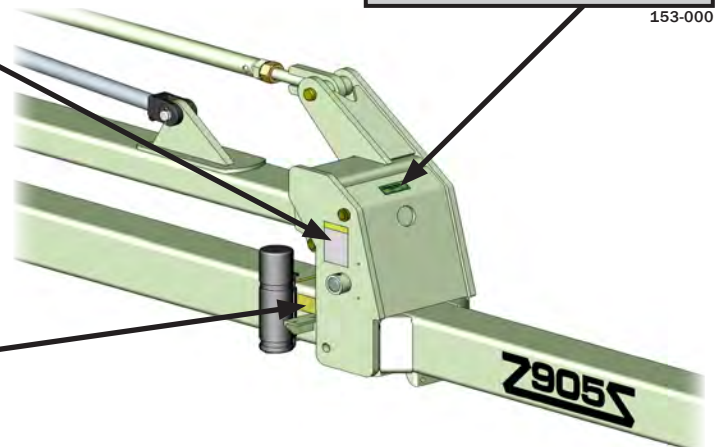

153-172 AMBER RETROREFLECTIVE

 SAFETY DECALS

 **IMPORTANT**

1. Equipment is to be operated by qualified personnel only. A full understanding of the operation, maintenance and safety requirements is mandatory before use.
2. Follow all tractor operating procedures and safety information.
3. Absolutely no riders on implement during operation. Severe bodily injury can result.
4. Before servicing or making adjustments to implement, disengage powertrain and/or shut off tractor, lower implement to the ground and/or provide safety support.

153-044

153-172 AMBER
RETROREFLECTIVE

ORTHMAN DECAL
153-000

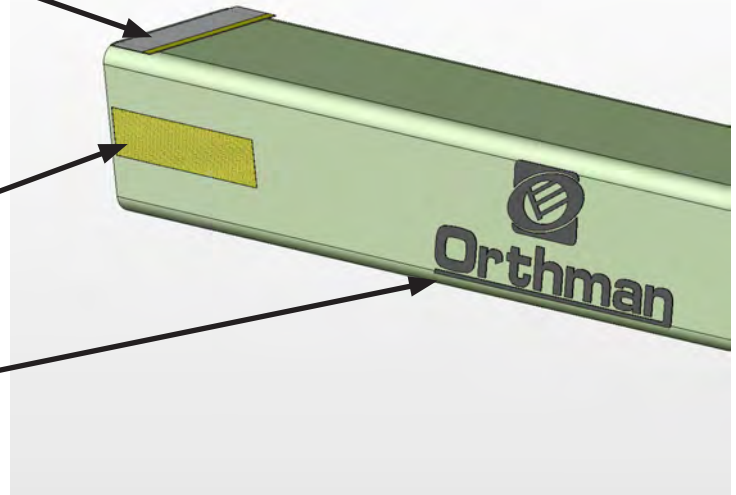

To ensure transport safety and efficiency, the slow moving vehicle (SMV) placard is not assembled or installed at Orthman Mfg., Inc. Refer to instructions below for installation of the SMV placard.

Recommended tools: 7/16" wrenches, screwdriver

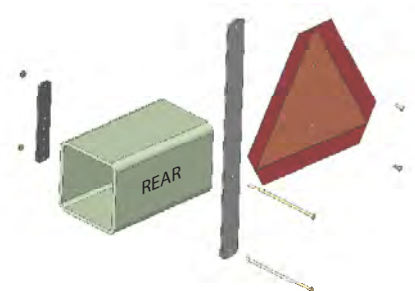
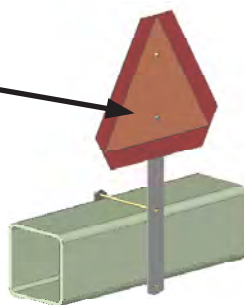
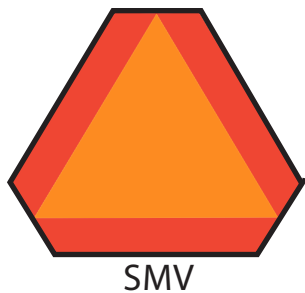

1. Locate a section of bare toolbar as close to the center of the implement as possible.
2. Use (2) 8" bolts and (2) flange nuts to secure SMV mount to toolbar.
3. Use (2) screws to attach SMV placard (facing rearward) to SMV mount.

SAFETY LIGHTING AND SAFETY DECALS

153-172 AMBER
RETROREFLECTIVE

FRONT OF TOOLBAR

153-171 ORANGE FLOURESCENT
NON-REFLECTIVE

153-173 RED
RETROREFLECTIVE

BACK OF TOOLBAR

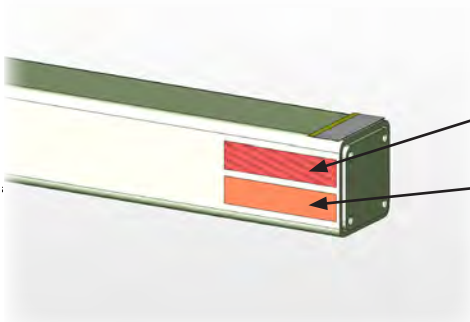

153-173 RED
RETROREFLECTIVE

153-171 ORANGE FLOURESCENT
NON-REFLECTIVE

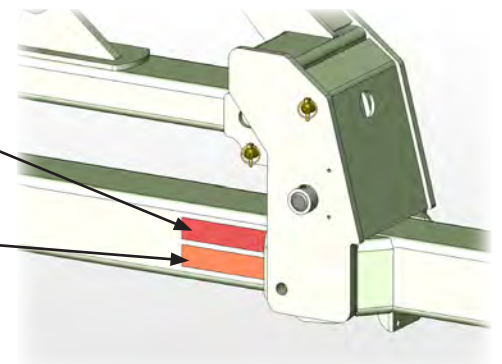

MAJOR COMPONENT IDENTIFICATION

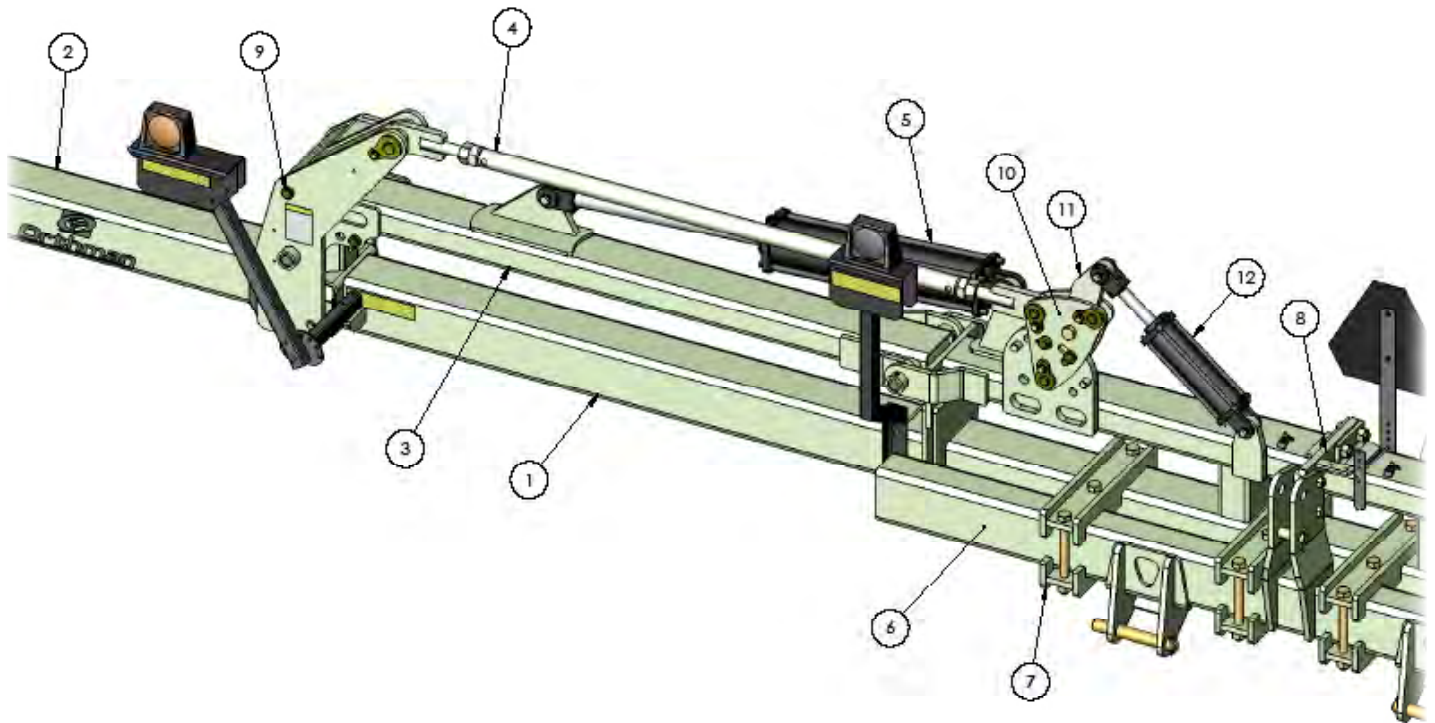

1. Center Section
2. Wing
3. Swing Truss
4. Leveling Link
5. Stacking Cylinder
6. 5x7 Orthman Hitch
7. 5x7 Orthman Hitch Clamp
8. Tie-Back Strap
9. Rigid Locking Pin (storage position)
10. Leveling Link Plate
11. Gull Wing Link-optional
12. Gull Wing Cylinder-optional

WARNING

1. Stay clear of stacking sections during raising and lowering.
2. Before transporting, insert pins in safety transport braces when wings are in upright position.
3. During transport, use extreme caution. Watch for low overhead objects and electrical wires. Drive carefully and slowly. Implement weight will make tractor less maneuverable.



CAUTION



DO NOT ATTEMPT TO STACK WINGS UNTIL YOU HAVE READ THE FOLLOWING PAGES.

PREPARING THE TOOLBAR

- Ensure all decals are in good, clean, and legible condition. Make sure each decal is correctly placed according to the safety section of this operator's manual. (pg. 2-7)
- Make sure tractor hydraulic system is in working order. Orthman 905 Series toolbar hydraulic systems are designed for a 3000 psi system.
- Make sure that hydraulic tips and outlets are free of foreign material. Foreign material can ruin hydraulic components resulting in adverse toolbar operation.
- 905 toolbar hydraulic assemblies are available from the factory in the standard (4 hose-2SCV) assembly, and an optional (2 hose - 1 SCV) assembly. The optional two hose assembly allows the wings to simultaneously be raised and lowered. The standard four hoses assembly allows for one wing to be manipulated at a time.

CAUTION! STACKING ONE WING AT A TIME CAUSES CENTER OF GRAVITY SHIFT RESULTING IN ROCKING AND UNBALANCED EQUIPMENT. USE EXTREME CAUTION WHEN MOVING UNBALANCED EQUIPMENT, THE TRACTOR AND IMPLEMENT ARE MORE LIKELY TO TIP.

- Attach hydraulic hoses to tractor according to cab preferences. **DO NOT STACK WINGS BEFORE REMOVING LOCKING PINS.** Recommended flow rate for hydraulic system is approximately 5 gallons per minute.

Be sure to consult the toolbar operator's manual prior to attempting to connect the implement to the tractor or operating the implement. Read and understand all operator's manuals for machinery used in conjunction with the 905 Series Toolbar.

Before each use, check all hardware for wear and proper torque (pg. 8 - 4). Replace damaged or missing hardware with hardware of an identical grade to restore implement to original specifications.

IMPLEMENT TO TRACTOR CONNECTION

AVOID CRUSHING. Do not stand between tractor and implement when connecting or disconnecting implement. Injury or death can result from being trapped between the tractor and implement.

AVOID CRUSHING. Make sure all personnel are clear of the implement. Lower implement to the ground, place tractor in park, turn off engine, and remove key.

USE BAR STANDS TO SUPPORT THE IMPLEMENT. Store implement on a clean, dry, and level surface. An uneven surface could cause implement to shift or fall, resulting in injury or death, as well as implement damage. Securely support all implement components that must be raised. Store implement away from human activity.

STACKING PROCESS

The 905 Series Toolbar will be delivered locked in a rigid position as shown with locking pins.

Each locking pin must be removed and placed in its storage position before wings stack.

⚠ WARNING

1. Stay clear of stacking sections during raising and lowering.
2. Before transporting, insert pins in safety transport braces when wings are in upright position.
3. During transport, use extreme caution. Watch for low overhead objects and electrical wires. Drive carefully and slowly. Implement weight will make tractor less maneuverable.

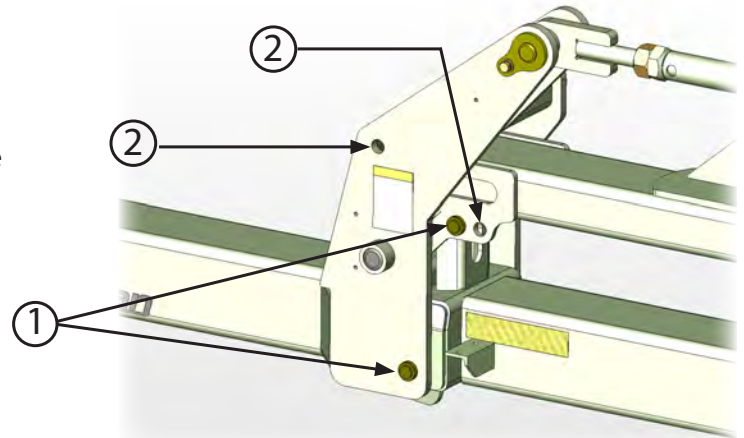

1. Locking Pins
2. Storage Position

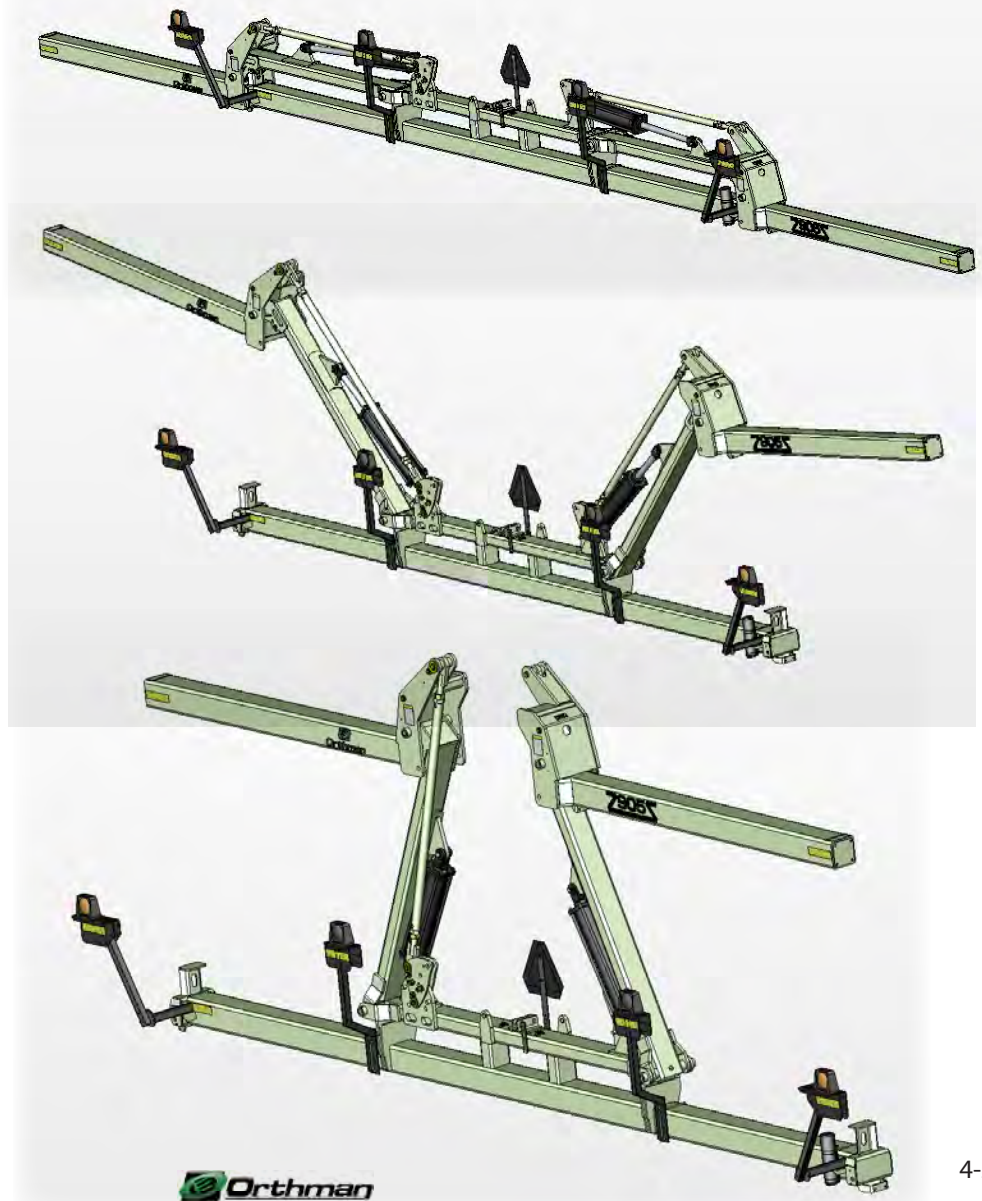

Wings are able to stack by applying hydraulic pressure with the tractor.

SAFETY LIGHTING

Inner Red Safety Light Assembly

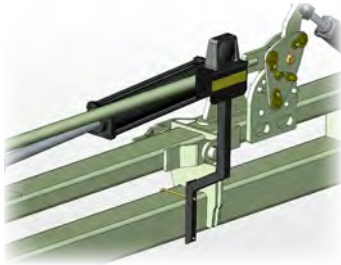

A safety lighting package, conforming to lighting standard ASAE S279-12, comes standard with all 905 Series Toolbars. Slow moving tractors and towed implements can create a hazard when driven on public roads. They are difficult to see, especially at night. The safety lighting greatly enhances safety while transporting the implement by increasing the visibility of the implement for all other motorists.

The safety lighting includes four lights, (two red and two amber) and all necessary decals. Keep all lights clean and in working order. Use safety lights on all public roads day and night. Comply with state and local laws governing warning and safety lighting.

Outer Light Assembly

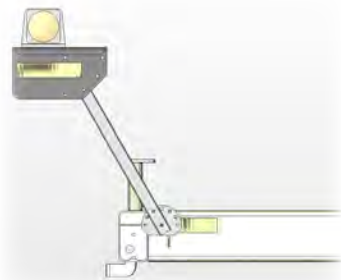

The red center section safety lights should be mounted equidistant from the center of the toolbar at a total distance not exceeding ten feet and no less than four feet. The center lights are mounted with the red lens facing away from the tractor. The amber outer safety lights are mounted to the toolbar hinges so during transport, the outermost portion of the implement is adequately lit. The amber outer lights must be mounted no more than 16 inches from the outermost extremity while in transport. The orange decal and the red reflective decal face away from the tractor. The amber reflective decals face toward the tractor. The outer amber safety lights are adjustable, and must be set up as shown in the figure to the left.

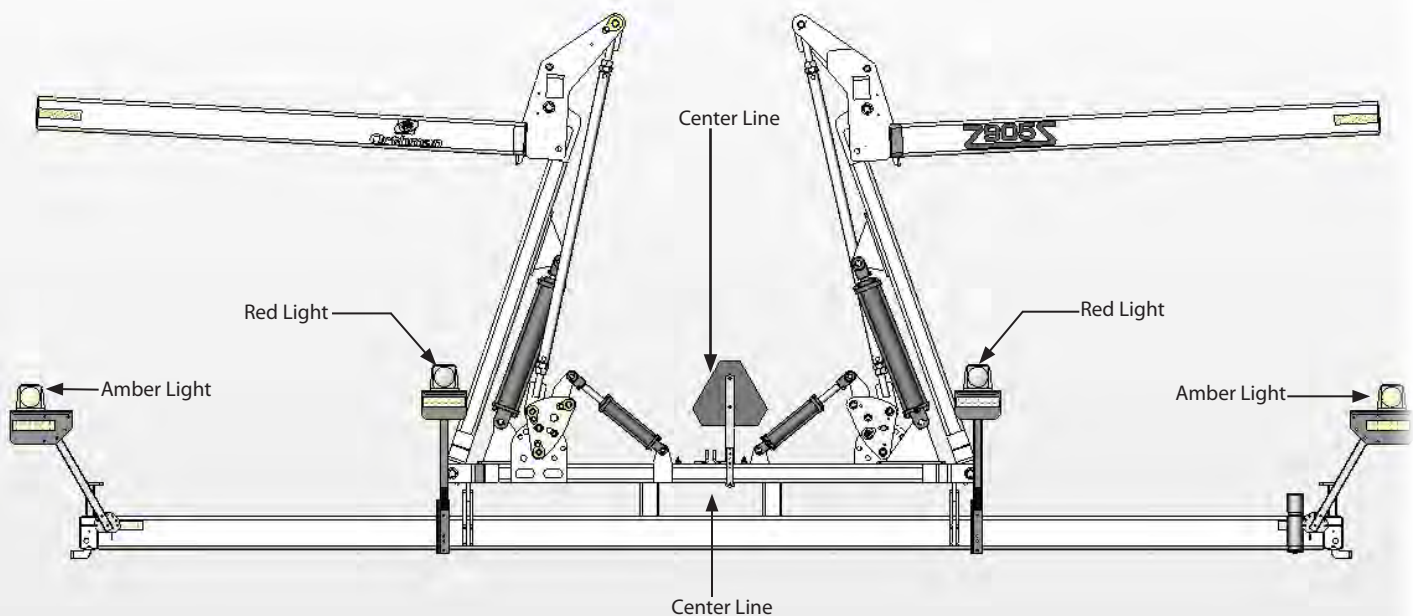

PREPARATION AND SETUP

GULL WING KIT

A gull wing kit is available for the 905 Stacker Bar. This kit allows the wings to float while going through the field, and can be engaged when turning around to tip the ends of the wings up 7 degrees to prevent the wings from sagging and catching on an obstacle when turning around.

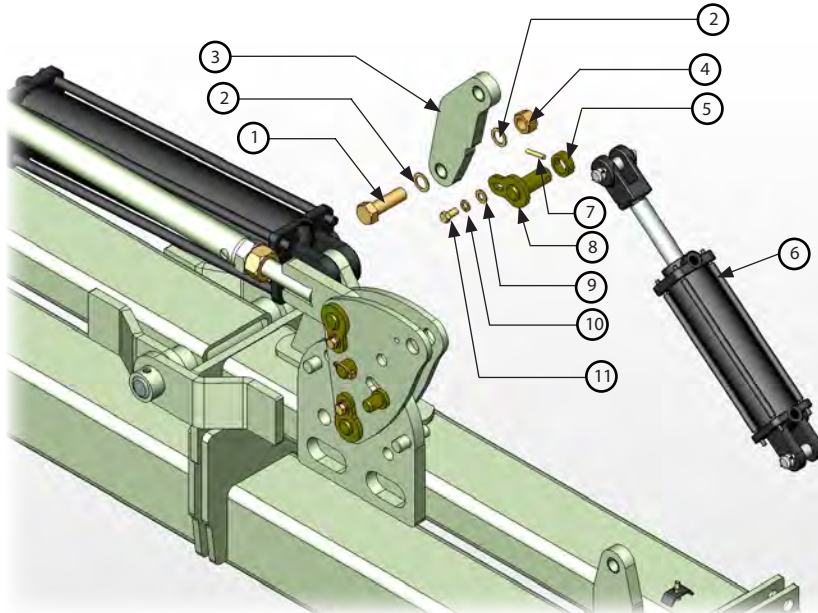

1. 100-195 1" x 3 1/4 Grade 8 Hex Bolt
2. 134-013 Wear Washer
3. 321-664 Banana Link (with 2 134-034 Bushings installed)
4. 102-162 1" Lock Nut
5. 301-793 Collar
6. 194-000 3" x 10" Cylinder
7. 104-008 5/16 x 1 3/4 Spiral Roll Pin
8. 321-665 Float Link Pin
9. 108-001 1/2 SAE Flat Washer
10. 108-020 1/2" Lock Washer
11. 100-114 1/2 x 1" Grade 5 Hex Bolt

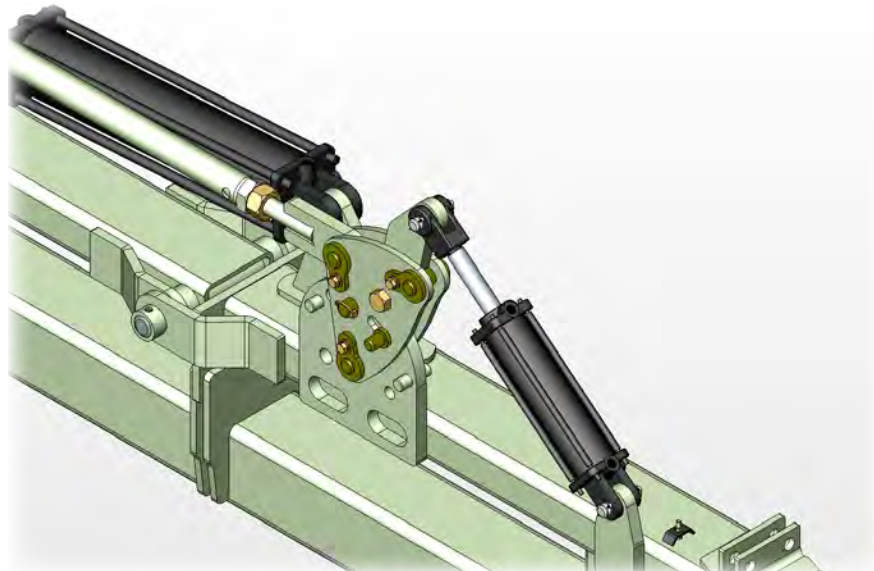

GULL WING HYDRAULIC SETUP

It is recommended that the gull wing kit be plumbed into a separate tractor hydraulic remote outlet. When plumbed this way the kit can be engaged with the hydraulic remote lever when turning around. When operating in field conditions where flex up and down is desired, the remote lever should be placed in the float position. When operating in field conditions where only flex up is desired, the remote lever can be placed in the neutral position.

Another option is connecting the gull wing kit with the lift assist wheels if LAW are plumbed into a hydraulic remote. (If the LAW are plumbed into the tractor three point hitch (rock shaft tap) then see third option below.) This will allow the gull wing kit to raise at the same time that the LAW are raised. However, with this setup, you do not have the ability to carry the LAW off of the ground while allowing the wings flex down.

A third option is connecting the gull wing kit with the tractor three point hitch (rock shaft tap). Please follow all tractor manufacturers instructions for installing and working with the rock shaft tap. Also note that some tractor manufacturers may NOT recommend using a rock shaft tap. Please note that Orthman Manufacturing will NOT be responsible for any damages or problems that may occur if using a rock shaft tap.

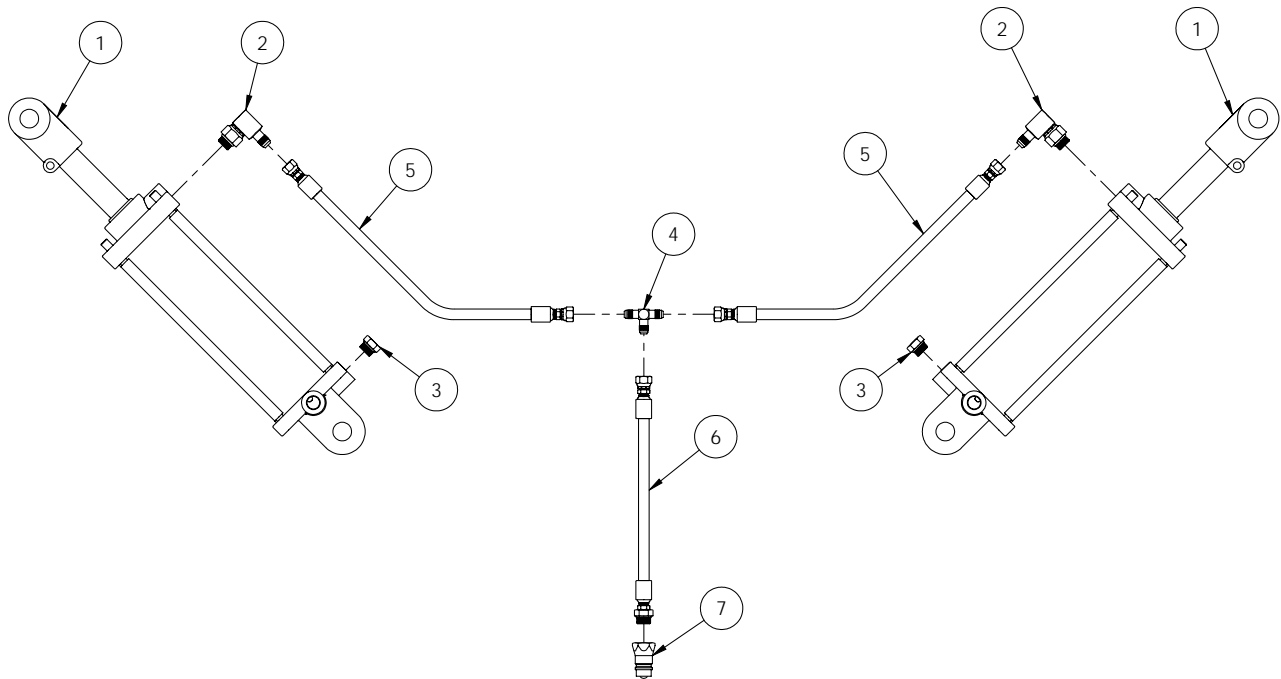

- | | | |
|----|---------|---------------------------------------|
| 1. | 194-000 | Cylinder (3 x 10 Tie Rod 3000) |
| 2. | 198-064 | Elbow (3/4 MB x 9/16 MJ 90 deg) |
| 3. | 194-233 | Breather (3/4 O-Ring) |
| 4. | 198-203 | Tee (9/16 MJ x 9/16 MJ x 9/16 MJ) |
| 5. | 301-464 | Hose 1/4" (9/16 FJX x 9/16 FJX x 48") |
| 6. | 196-254 | Hose 3/8" (9/16 FJX x 3/4 MORB x 60") |
| 7. | 140-092 | Tip (ISO Tractor) |
| 8. | 152-712 | Dustcap for tip (green) (not shown) |

PREPARATION AND SETUP**SEMI-MOUNTED OPERATION WITH LIFT ASSIST WHEELS**

When using a Lift Assist Wheel the Stacker Bar must run in a semi-mounted setup (top link disconnected) unless an accumulator or other means of protection for the tractor top link has been included. The reason for this is if the rear tractor tires go through a ditch or hole, the tractor top link or hitch mast can be crushed as the rear of the tractor tips backwards while the implement stays stationary. Refer to Lift Assist Wheel manufacturers instructions for more information.

When running in a semi-mounted configuration a quick hitch **MUST** be used to prevent Stacker Bar from tipping forward in the event of a sudden stop. See warning below. It is also recommended that the operator shorten the third link on the tractor to tip the top of the quick hitch towards the tractor. This is to allow the Stacker Bar to have the greatest range of motion possible for crossing ditches or other uneven terrain. Do **NOT** shorten top link enough to allow the Stacker Bar to come into contact with the tractor cab should the Stacker Bar tip forward. See warning below.



If running the Stacker Bar in a semi-mounted configuration a quick hitch **MUST** be used even though the top link is not pinned. This is to prevent the Stacker Bar from tipping forward into the tractor when in transport mode in the event of a sudden stop!

HYDRAULIC HOSE TEE PACKAGE

Standard 4 Hose-2 SCV

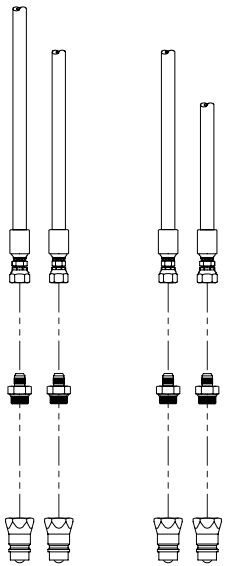

Optional Tee Package

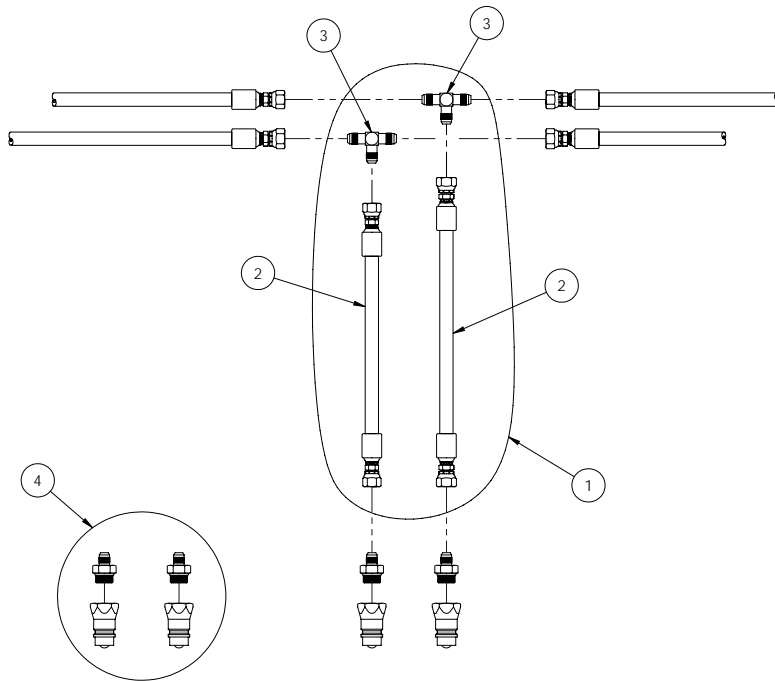

	<p>⚠ DANGER</p> <p>HIGH-PRESSURE FLUID HAZARD</p> <p>To prevent serious injury or death:</p> <ul style="list-style-type: none"> • Relieve pressure on hydraulic system before servicing or disconnecting hoses. • Wear proper hand and eye protection when searching for leaks. Use wood or cardboard instead of hands. • Keep all components in good repair. <p style="text-align: right; font-size: small;">153-928</p>

Parts shown above:

1. 612-640 Orthman Hydraulic Hose Tee Package
2. 301-464 4' hydraulic hose (1/4 hose 9/16 FJX x 9/16 FJX)
3. 198-203 Tee (9/16 MJIC x 9/16 MJIC x 9/16 MJIC)
4. ISO tractor tips and adaptors (left over from conversion)

Escaping pressurized hydraulic fluid can penetrate skin, resulting in injury or death. Relieve hydraulic system pressure before connecting or disconnecting tractor. Use cardboard or wood, **NOT BODY PARTS**, to check for suspected leaks. Wear protective gloves and safety glasses or goggles when working with hydraulic systems. If an accident occurs, see a doctor immediately for proper treatment.

USE BAR STANDS TO SUPPORT THE IMPLEMENT. Park implement on a clean, dry, and level surface. An uneven surface could cause implement to shift or fall, resulting in injury or death, as well as implement damage. Securely support all implement components that must be raised. Remove buildup of grease, oil, or debris prior to installing the hydraulic flow divider.

An Orthman hydraulic hose tee package connects left and right stacking sections in order to use one SCV to stack and unstack wing sections simultaneously.

To install the hydraulic hose tee package remove ISO tractor tips from all 4 hoses. The adaptors may be left on the tips. Hydraulic hose tee package consists of 2 hoses and 2 tee fittings.

Install tee fitting between the hose that comes from the base end of the stacking cylinder on the right side to the hose that comes from the base end of the stacking cylinder on the left side. This will tie the two pressure hoses together. Next install tee fitting between the hose that comes from the rod end of the stacking cylinder on the right side to the hose that comes from the rod end of the stacking cylinder on the left side. This will tie the two return hoses together. Next take the two hoses supplied in the tee package kit and install them into the tee fittings shown above. Next install 2 adaptors and ISO tractor tips to these hoses. You will have 2 adaptors and 2 ISO tractor tips left over.

The stacker bar should now stack both wings at the same time.

WING COUPLER KIT

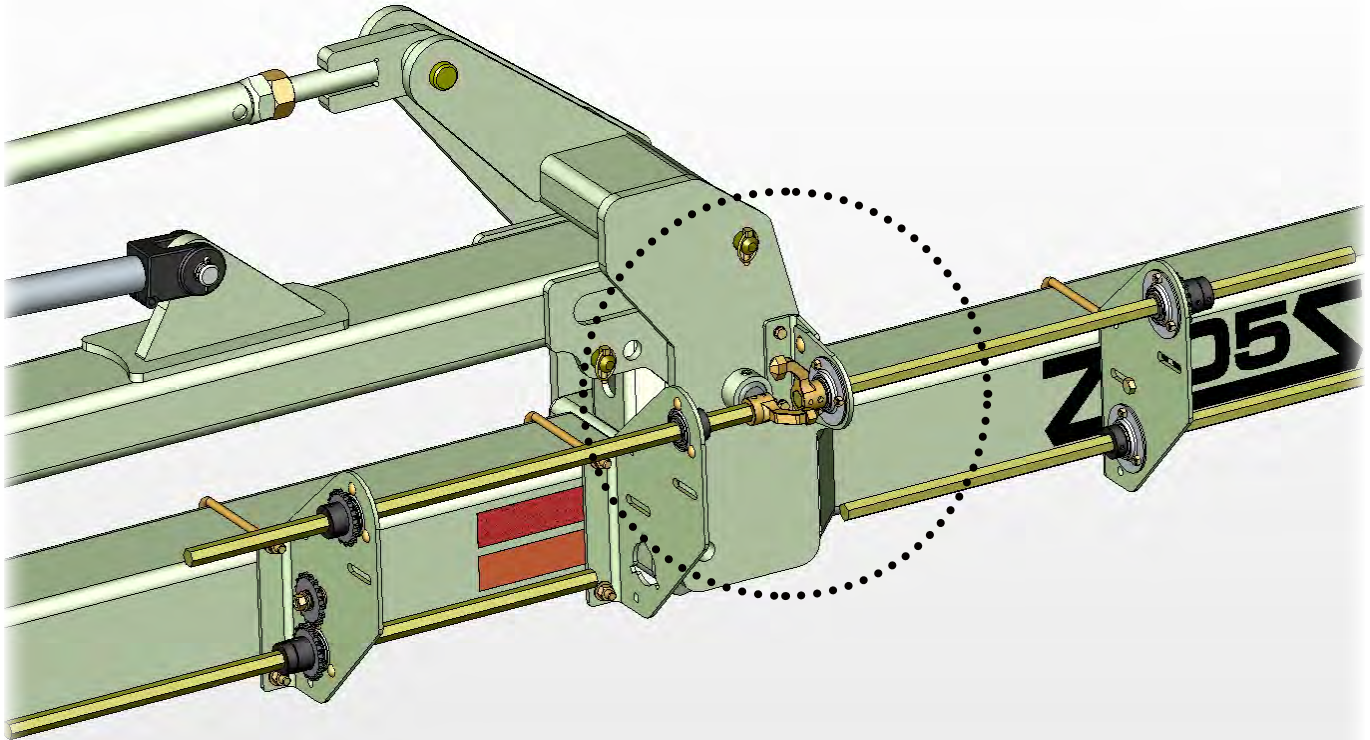
**WARNING****MOVING PART HAZARD.**

TO PREVENT SERIOUS INJURY OR DEATH FROM MOVING PARTS, KEEP HANDS, FEET, HAIR, AND CLOTHING AWAY FROM MOVING PARTS.

DISCONNECT POWER SOURCE BEFORE SERVICING.

Wing coupler kits are available for those who choose to utilize the 905 Series Toolbar for planting purposes.

Coupler kits alleviate the need for additional drive devices for wing units. The universal joint allows for the wings to stack keeping the planter drive shaft intact for transport and flex for uneven terrain during planting.

Sold separately, the wing coupler kit is a cost effective method of eliminating the need for additional planter drives for wing units.

FLOAT OPERATION AND GULL WING HYDRAULIC KIT

- Make sure all bar stands are in the raised position.
- Make sure three point pins are not excessively worn.
Make sure implement is attached securely to three point tractor hitch.

DO NOT STAND BETWEEN TRACTOR AND IMPLEMENT WHEN HOOKING OR UNHOOKING TO AVOID CRUSHING.



	DANGER
	<p>HIGH-PRESSURE FLUID HAZARD</p> <p>To prevent serious injury or death:</p> <ul style="list-style-type: none"> • Relieve pressure on hydraulic system before servicing or disconnecting hoses. • Wear proper hand and eye protection when searching for leaks. Use wood or cardboard instead of hands. • Keep all components in good repair. <p style="text-align: right; font-size: small;">153-528</p>

- Make sure cab hydraulic control configuration is easily accessible and to the preference of the primary operator.
- Make sure hydraulic hookups between tractor and implement are securely fastened.
- Make sure tractor is adequately ballasted for safe operation.
Refer to tractor owner’s manual for proper ballasting instructions.

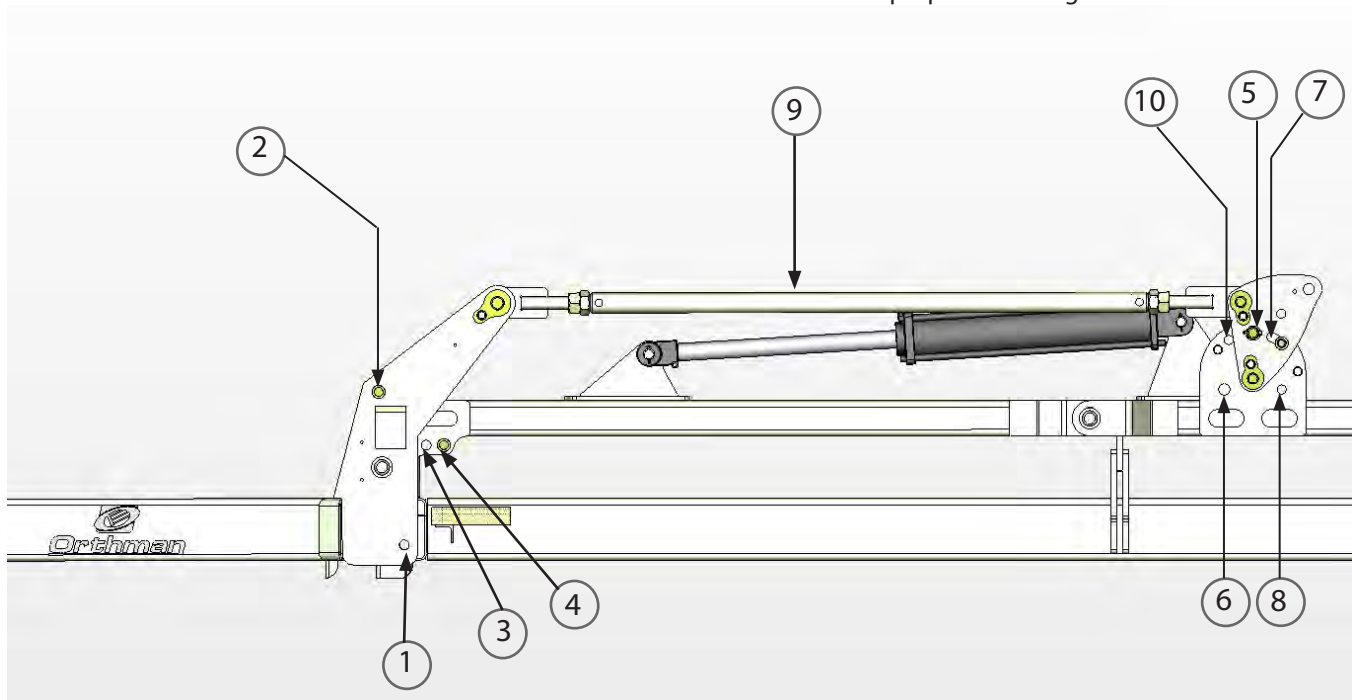

(Refer to this picture for pin positions)

1. Wing Lock Position
2. Wing Lock Storage Position
3. Swing Truss Lock Pin Position
4. Swing Truss Lock Pin Storage Position
5. Float Link Center Pin Position
6. Float Link Center Pin Storage Position
7. Float Link Stop Pin Position
8. Float Link Stop Pin Storage Position
9. Leveling Link
10. Float Link Stop Alternate Pin Position

WING FLOAT OPERATION

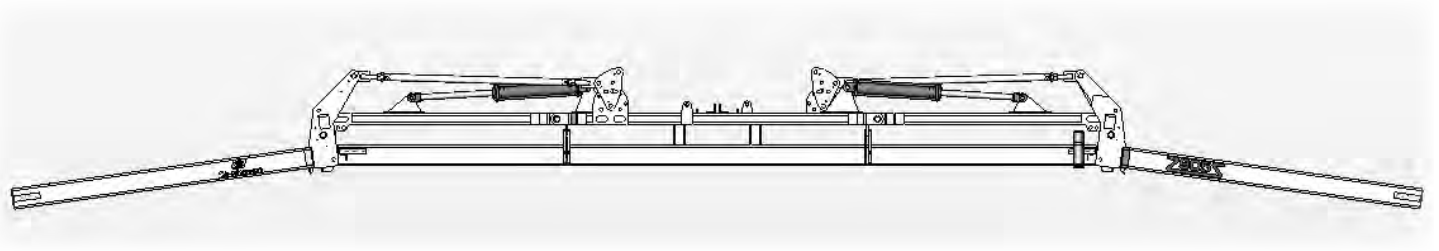

OPERATING MODES

The 905 Series Stacker Bar can be set for one of three different operating modes:

- Rigid
- Full float-can be used in combination with the Gull Wing Kit
- Float up-can be used in combination with the Gull Wing Kit

Refer to the display on pg 5-1 for adjustments and pin positions notated in this section.

Rigid Operation: Rigid mode should be used when operation requires a completely rigid bar. For example, if the 905 bar is being used as a planter and the drive wheels are located on the wing, the rigid position would be necessary.

Wing Lock Pin should be inserted into Wing Lock Position. (1)

Note: 905 Stacker Bar will not stack with Wing Lock Pin inserted into Wing Lock Pin position.

Swing Truss Lock Pin should be inserted into Swing Truss Lock Pin Storage position. (3)

Note: 905 Stacker Bar will not stack with Swing Truss Lock Pin inserted into Swing Truss Lock Pin Position.

Float Link Center Pin should be inserted into Float Link Center Pin position. (5)

Float Link Stop Pin should be inserted into Float Link Stop Pin position. (7)

For transporting, move Wing Lock Pin to Pin Storage Position (2) and move Swing Truss Lock Pin to Swing Truss Lock Pin Storage Position (4) before stacking toolbar.

Float Link Center Pin should be inserted into Float Link Center Pin position. (5)

Float Link Stop Pin should be inserted into Float Link Stop Pin position. (7)

For transporting, move Wing Lock Pin to Pin Storage Position (2) and move Swing Truss Lock Pin to Swing Truss Lock Pin Storage Position (4) before stacking toolbar.

Orthman Gull Wing Kit will not operate in Rigid Operation mode.

OPERATING MODES CONT.



(refer to the display on page 5-1 for float operation and gull wing adjustments)

Float Up Operation: Float Up mode will allow wing to rotate about the wing hinge approximately 7 degrees up and can be useful in rolling, uneven terrain. Without a Gull Wing Kit, having the 905 set in the Float Up position will result in the wings gravitating down to level during raised field position (field turn around). Due to this, Full Float mode is more effective with the addition of a Gull Wing Kit. (pg. 4-6)

Wing Lock Pin should be inserted into Wing Lock Storage position. (2)

Swing Truss Lock Pin should be inserted into Swing Truss Lock Pin position. (3)

Note: 905 Stacker Bar will not stack with Swing Truss Lock Pin inserted into Swing Truss Lock Pin position.

Float Link Center Pin should be inserted into Float Link Center Pin Storage position. (6)

Float Link Stop Pin should be inserted into Float Link Stop Pin position. * (7)

For transporting, move Swing Truss Lock Pin to Pin Storage Position (4) before stacking toolbar.

Place Gull Wing Kit SCV lever in neutral position to allow toolbar wings to float up.

(refer to the display on page 5-1 for float operation and gull wing adjustments)

Full Float Operation: Full Float mode will allow wing to rotate about the wing hinge pin approximately 7 degrees up and 7 degrees down and can be useful in rolling, uneven terrain. Without a Gull Wing Kit, having the 905 set in the Full Float position will result in the wings gravitating down the full 7 degrees during raised field position (field turn around). Due to this, Full Float mode is more effective with the addition of a Gull Wing Kit. (pg 4-6)

Wing Lock Pin should be inserted into Wing Lock Storage Position. (2)

Swing Truss Lock Pin should be inserted into Swing Truss Lock Pin Position. (3)

Note: 905 Stacker Bar will not stack with Swing Truss Lock Pin inserted into Swing Truss Lock Pin Position.

Float Link Center Pin should be inserted into Float Link Center Pin Storage Postion. (6)

Float Link Stop Pin should be inserted into Float Link Stop Pin Storage Postion.* (8)

For transporting, move Swing Truss Lock Pin to Pin Storage Position (4) before stacking toolbar.

Place Gull Wing Kit SCV lever in float position to allow toolbar wings to float up and down.

OPERATING MODES CONT.

(refer to the display on page 5-1 for float operation and gull wing adjustments)

*Note - For removing Float Link Stop Pin the Leveling Link may need to be adjusted. If this is done, be sure to return the Leveling Link (9) to it's original setting to make the wings level. To re-install the Float Link Stop Pin, lower toolbar until wings begin to float up and Float Link Stop Pin can be inserted into Float Link Stop Pin position. (7)

Next, raise toolbar until Float Link comes up tight against Float Link Stop Pin. Float Link Center Pin holes should be aligned. Insert Float Link Center Pin into Float Link Center Pin position. (5)

An alternate way would be to utilize any 1" pin in the Float Link Stop Alternate Pin Position (10) to stop against.

GULL WING OPERATION

	⚠ DANGER
	<p>HIGH-PRESSURE FLUID HAZARD</p> <p>To prevent serious injury or death:</p> <ul style="list-style-type: none"> • Relieve pressure on hydraulic system before servicing or disconnecting hoses. • Wear proper hand and eye protection when searching for leaks. Use wood or cardboard instead of hands. • Keep all components in good repair. <p style="text-align: right; font-size: small;">453-628</p>

The 905 Series Stacker Bar Gull Wing feature can be used in combination with the float up and full float operations (pg. 5-3).

Place hydraulic SCV lever connected to the Gull Wing Kit in the neutral position when the 905 is set for float up operation to allow wings to float up.

Place hydraulic SCV lever connected to the Gull Wing Kit in the float position when the 905 is set for full float operation to allow wings to float up and down.

Gull Wing Kit will not operate when the 905 is set for rigid operation.

The gull wing kit can be engaged with the hydraulic remote lever when turning around to tip the wings up 7 degrees to prevent wings from sagging and catching objects.

Refer to page 4-6 for hydraulic options.

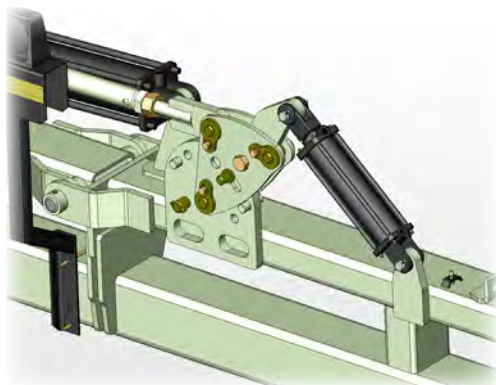

Gull wing in Float up operation (shown engaged)



Gull Wing up

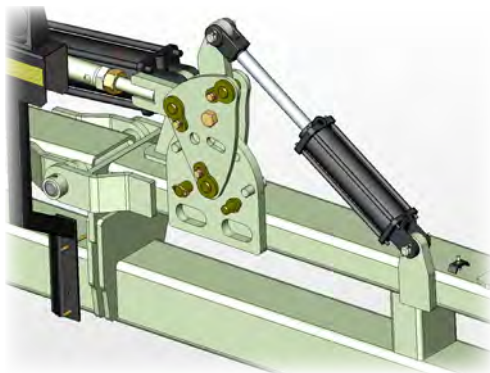

In full float operation gull wing kit will extend to allow full float down when SCV for gull wing kit is placed in float.

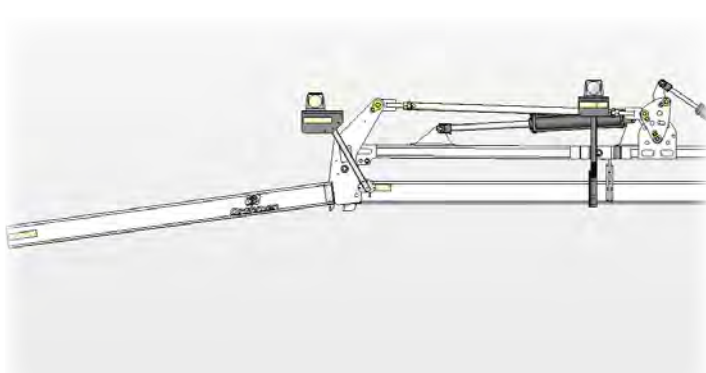

Full Float down

TROUBLESHOOTING



AVOID CRUSHING. *Make sure all personnel are clear of the implement. Lower implement to the ground, place tractor in park, turn off engine, and remove key.*

USE BAR STANDS TO SUPPORT THE IMPLEMENT. *Park implement on a clean, dry, and level surface. An uneven surface could cause implement to shift or fall, resulting in injury or death, as well as implement damage. Securely support all implement components that must be raised. Remove buildup of grease, oil, or debris prior to working on the implement.*

**PROBLEM: TOOLBAR DOES NOT OPERATE AT PROPER HEIGHT.**

Completely raise toolbar gauge wheels. Have an assistant pull the tractor and implement slowly forward in the field position. As the implement travels forward, manipulate tractor hitch height from the cab of the tractor until recommended operating height is achieved. Stop tractor and physically measure toolbar height. If toolbar is not to correct operation height. Repeat procedure.

Once correct toolbar height is established, lower toolbar gauge wheels to ground surface, if equipped, or set lower hitch stop on the tractor. These settings will provide a consistent toolbar height when in operation.

PROBLEM: TOOLBAR DOES NOT OPERATE PARALLEL WITH GROUND SURFACE.

Presuming correct toolbar height has been achieved, lengthen (tip back) or shorten (tip forward) the tractor third link until toolbar is parallel with ground surface. Tractor hitch height may have to be manipulated in order to lengthen or shorten third link. Make sure the implement is in the field position when adjusting the toolbar to operate parallel with ground surface.

Make adjustments to the tractor lower hitch stop, third link, and toolbar gauge wheels, if equipped, until the toolbar operates at the correct height and orientation.

TROUBLESHOOTING



AVOID CRUSHING. Make sure all personnel are clear of the implement. Lower implement to the ground, place tractor in park, turn off engine, and remove key.



USE BAR STANDS TO SUPPORT THE IMPLEMENT. Park implement on a clean, dry, and level surface. An uneven surface could cause implement to shift or fall, resulting in injury or death, as well as implement damage. Securely support all implement components that must be raised. Remove buildup of grease, oil, or debris prior to working on the implement.



PROBLEM: WING DO NOT STACK

SOLUTION:

1. Tractor hydraulic pressure is insufficient.

*Refer to tractor operator's manual or dealer for tractor hydraulic specifications.

2. Hydraulic tips installed incorrectly in tractor SCV.

*Refer to tractor operator's manual for tractor SCV information.

3. Cylinder seal kit is bad.
4. Lock pins are installed.
5. Wings are overloaded.

NOTE: To avoid foreign objects in hydraulic oil, always clean hydraulic tips and outlets. Foreign material can ruin cylinders and plug restrictors.

OUTER HINGE ASSEMBLY

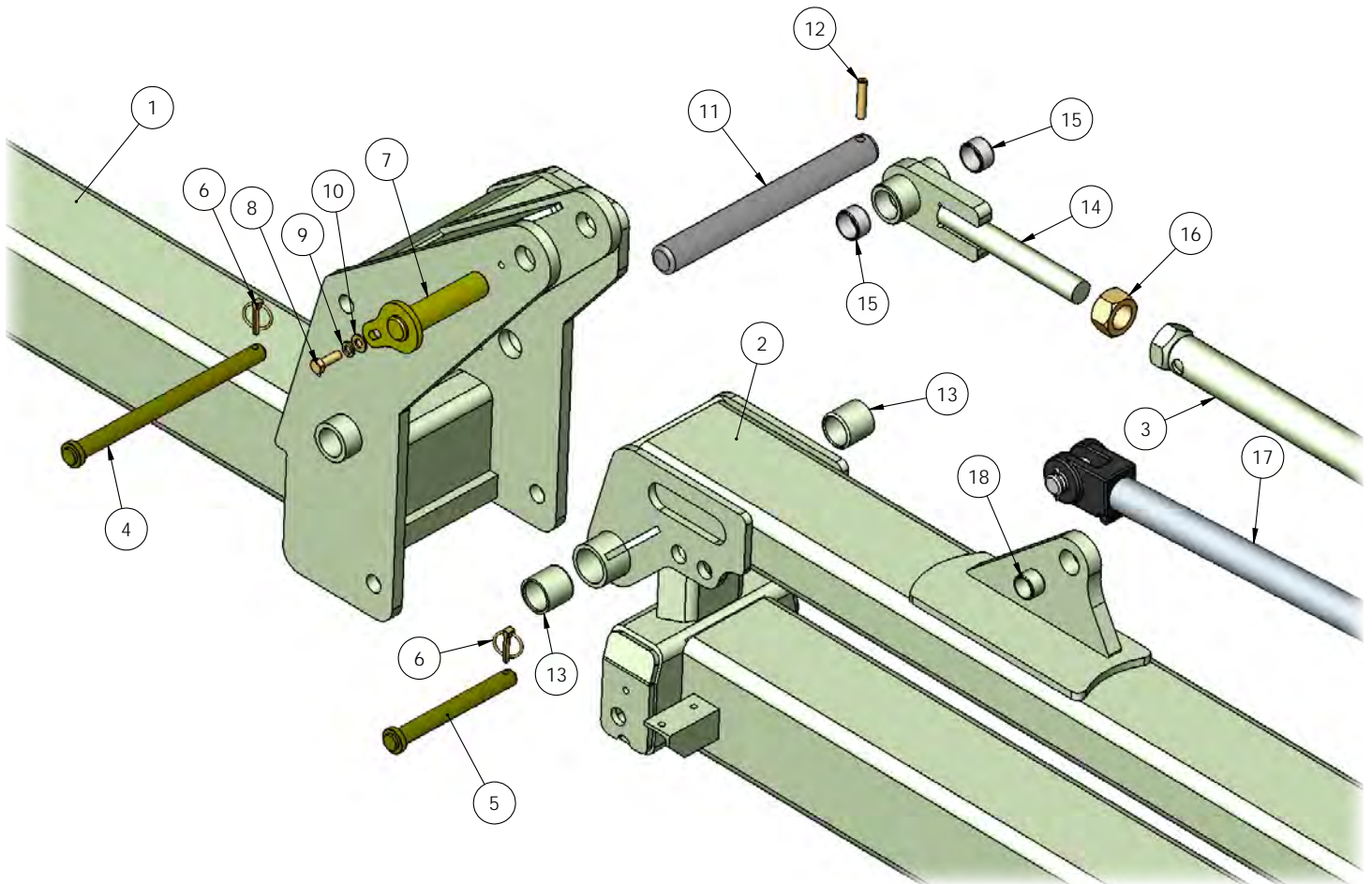

All hardware is coarse threaded unless otherwise noted.

- | | |
|-------------|--|
| 1. Call | Wing |
| 2. 321-600 | Swing Truss |
| 3. 301-871 | Turnbuckle Tube |
| 4. 301-156 | Wing Lock Pin |
| 5. 321-672 | Swing Truss Lock Pin |
| 6. 104-065 | Linch Pin |
| 7. 321-670 | Strut Pin |
| 8. 100-116 | Hex bolt 1/2 x 1 1/2 grade 5 |
| 9. 108-020 | Lock washer 1/2 |
| 10. 108-001 | Flat washer 1/2 SAE |
| 11. 301-146 | Hinge pin |
| 12. 104-005 | Roll pin 1/2 x 2 1/2 HD spiral |
| 13. 134-005 | Bushing |
| 14. 321-641 | Turnbuckle end Right (includes bushings) |
| 15. 134-017 | Bushing |
| 16. 102-117 | Hex nut 1 1/2 grade 2 |
| 17. 194-194 | Cylinder 5 x 24 |
| 18. 134-044 | Bushing |

CENTER ASSEMBLY

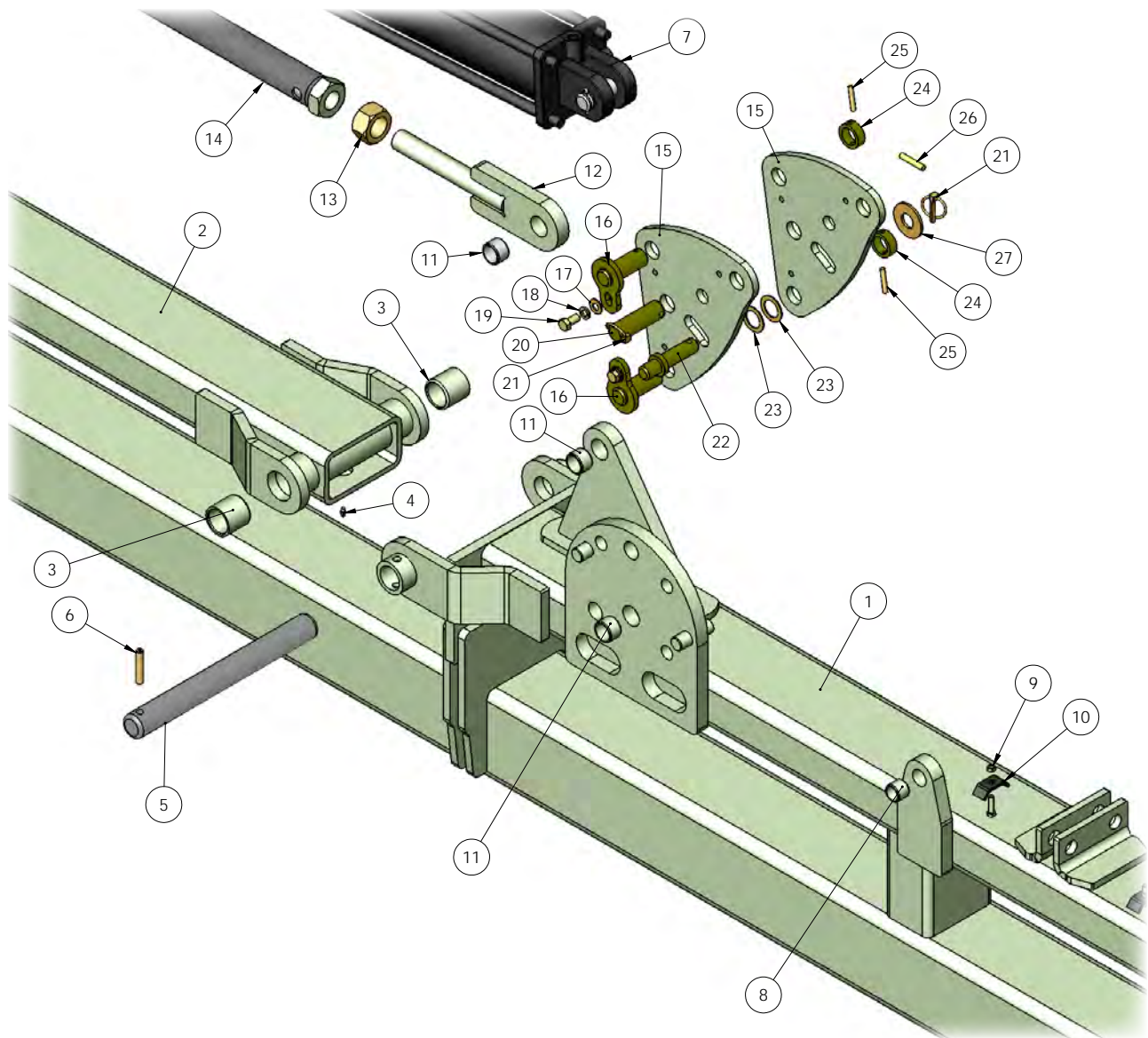

- | | | | |
|-------------|-------------------------------------|-------------|------------------------------|
| 1. Call | Center Section | 15. 321-662 | Float Link Plate |
| 2. 321-600 | Swing Truss (includes all bushings) | 16. 321-665 | Float Link Pin |
| 3. 134-005 | Bushing | 17. 108-001 | Flat washer 1/2 SAE |
| 4. 110-001 | Grease Fitting | 18. 108-020 | Lock Washer 1/2 |
| 5. 301-146 | Hinge Pin | 19. 100-114 | Hex Bolt 1/2 x 1" grade 5 |
| 6. 104-005 | Roll Pin 1/2 x 2 1/2 HD spiral | 20. 321-667 | Float Link Center Pin |
| 7. 194-194 | Cylinder 5" x 24 | 21. 104-065 | Linch Pin 5/16 x 1 11/16 |
| 8. 134-034 | Bushing | 22. 321-668 | Float Link Stop Pin |
| 9. 102-025 | Lock Nut 5/16 | 23. 134-103 | Wear Washer |
| 10. 318-460 | Hose strap | 24. 301-793 | Collar |
| 11. 134-044 | Bushing | 25. 104-008 | Roll Pin 5/16 x 1 3/4 spiral |
| 12. 301-875 | Turnbuckle Screw Left | 26. 104-103 | Roll Pin 3/8 x 2" |
| 13. 102-118 | Hex nut 1 1/2 left hand threads | 27. 108-014 | Flat Washer 1" |
| 14. 301-871 | Turnbuckle linkage tube | | |

STACK FOLD HYDRAULIC ASSEMBLY

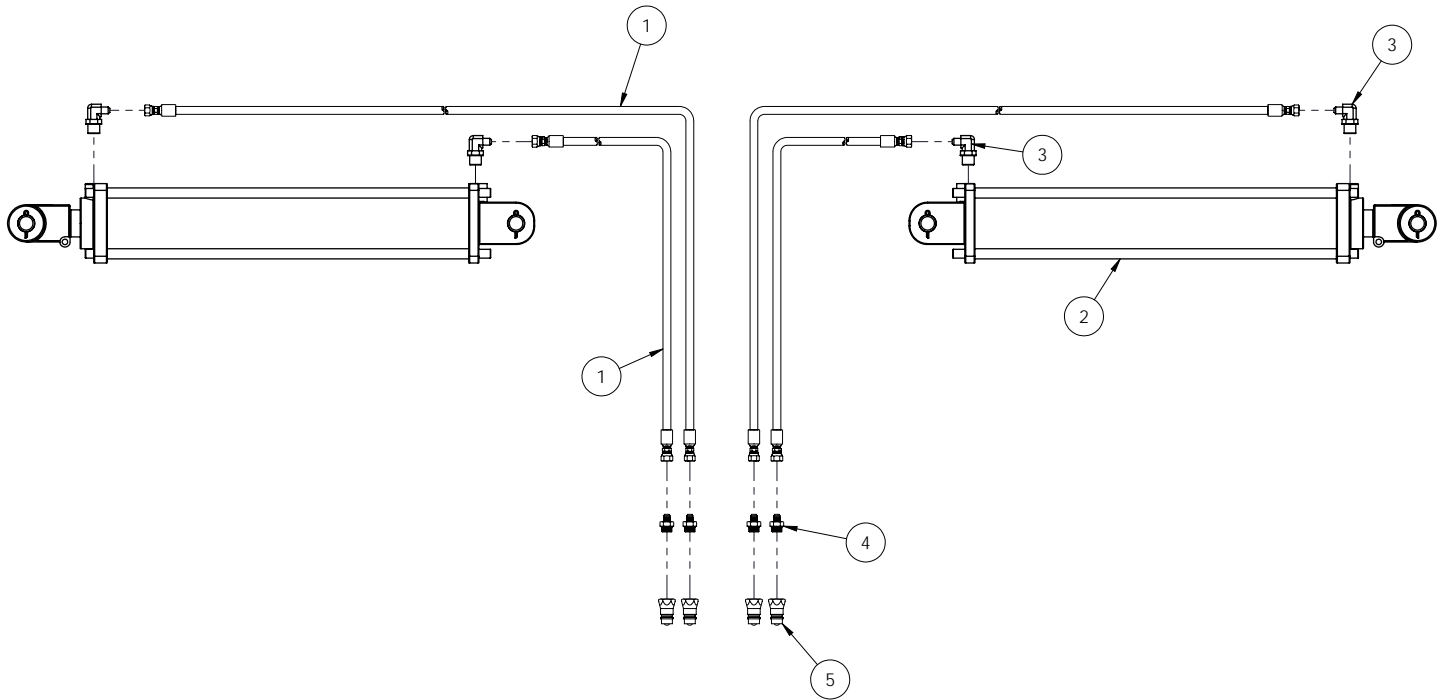

905 Hydraulic Assembly

1. 1/4" Hydraulic Hose 9/16 FJX x 9/16 FJX ends

- 196-141 9 ft.
- 196-114 10 ft.
- 196-118 11 ft.
- 196-119 12 ft.
- 196-454 13 ft.
- 196-165 14 ft.

2. 194-194 cylinders 5 x 24

3. 198-080 elbows 7/8 MB x 9/16 MJ

4. 198-078 adaptors 3/4 MB x 9/16 MJ

5. 140-092 ISO tractor tips 3/4 O-ring

Parts listing for Gull Wing Kit shown on pgs. 4-5 and 4-6.

Parts for Hydraulic Hose Tee package shown on pg 4-8.

SAFETY LIGHTS ASSEMBLY

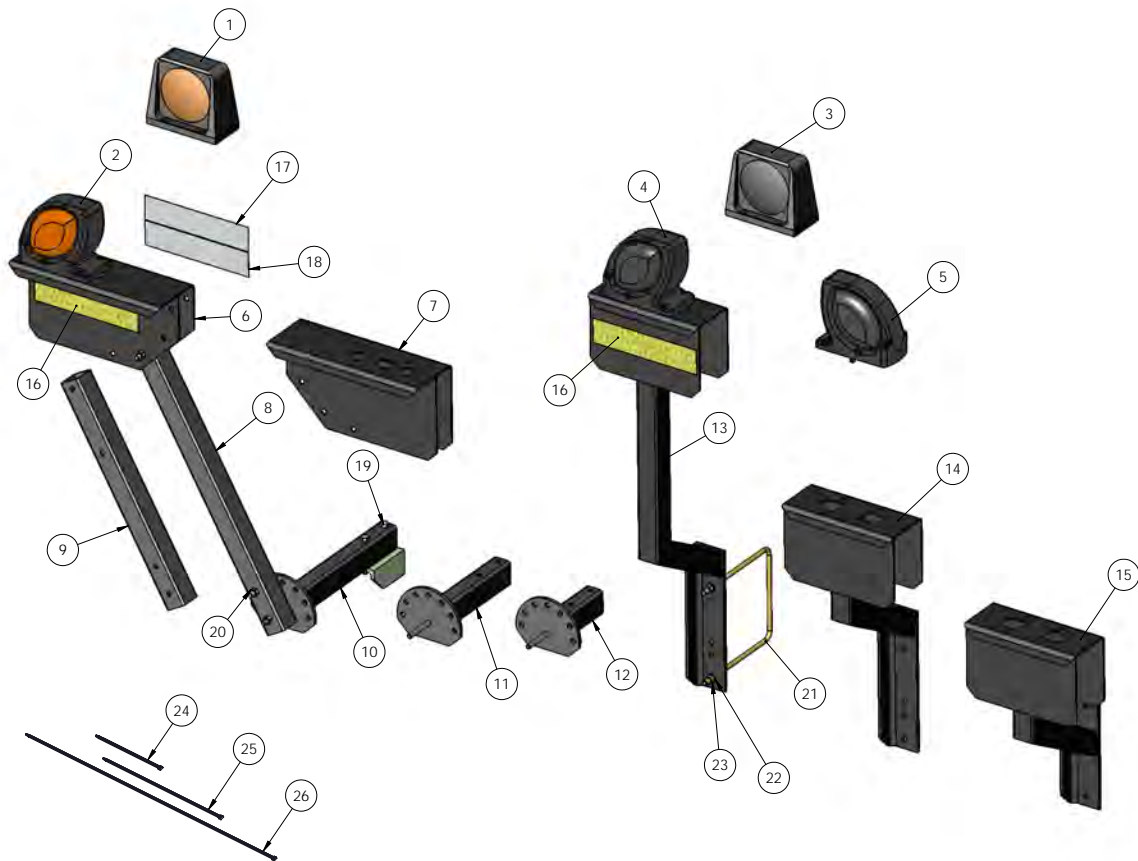

1. 152-875 Amber Flashing Light (Wesbar Brand)
2. 152-950 Amber Flashing Light (Cobo Brand)
3. 152-874 Red Tail Light (Wesbar Brand)
4. 152-951 Red Tail Light Right (Cobo Brand) (image shown with red lens to rear)
5. 152-952 Red Tail Light Left (Cobo Brand) (image show with red lens to rear)
6. 301-567 Adjustable Light Bracket Right (sometimes used on left for some products)
7. 301-568 Adjustable Light Bracket Left (sometimes used on right for some products)
8. 301-563 Adjustable Light Arm (28 1/4" long)
9. 301-035 Adjustable Light Arm (18 1/4" long)
10. 321-713 Adjustable Light Mount (13 1/4" long)
11. 301-562 Adjustable Light Mount (9 1/8" long)
12. 301-037 Adjustable Light Mount (5 3/4" long)
13. 301-574 Center Light Bracket (26 1/2" tall from bar to light mounts) (decals not included)
14. 301-573 Center Light Bracket (14 1/4" tall)
15. 355-065 Light Bracket (9 1/4" tall)
16. 153-172 Amber Retroreflective (yellow decal)
17. 153-173 Red Retroreflective (red decal)
18. 153-171 Orange Florescent decal
19. 100-113 3/8 x 2 3/4 Grade 5 Hex Bolt (used on all bolted connections)
20. 102-056 3/8 Nylon Lock Nut (used on all connections except for u-bolts)
21. 315-026 U-Bolt 3/8 (7" x 7" toolbar)
- 315-025 U-Bolt 3/8 (5" x 7" toolbar)
22. 108-018 3/8 Lock Washer
23. 102-005 3/8 Grade 2 Hex Nut
24. 152-021 7" Cable Tie
25. 152-024 13" Cable Tie
26. 152-023 28" Cable Tie
- 152-055 12" Cable Tie (not shown)

LIGHTS AND CABLES ASSEMBLY

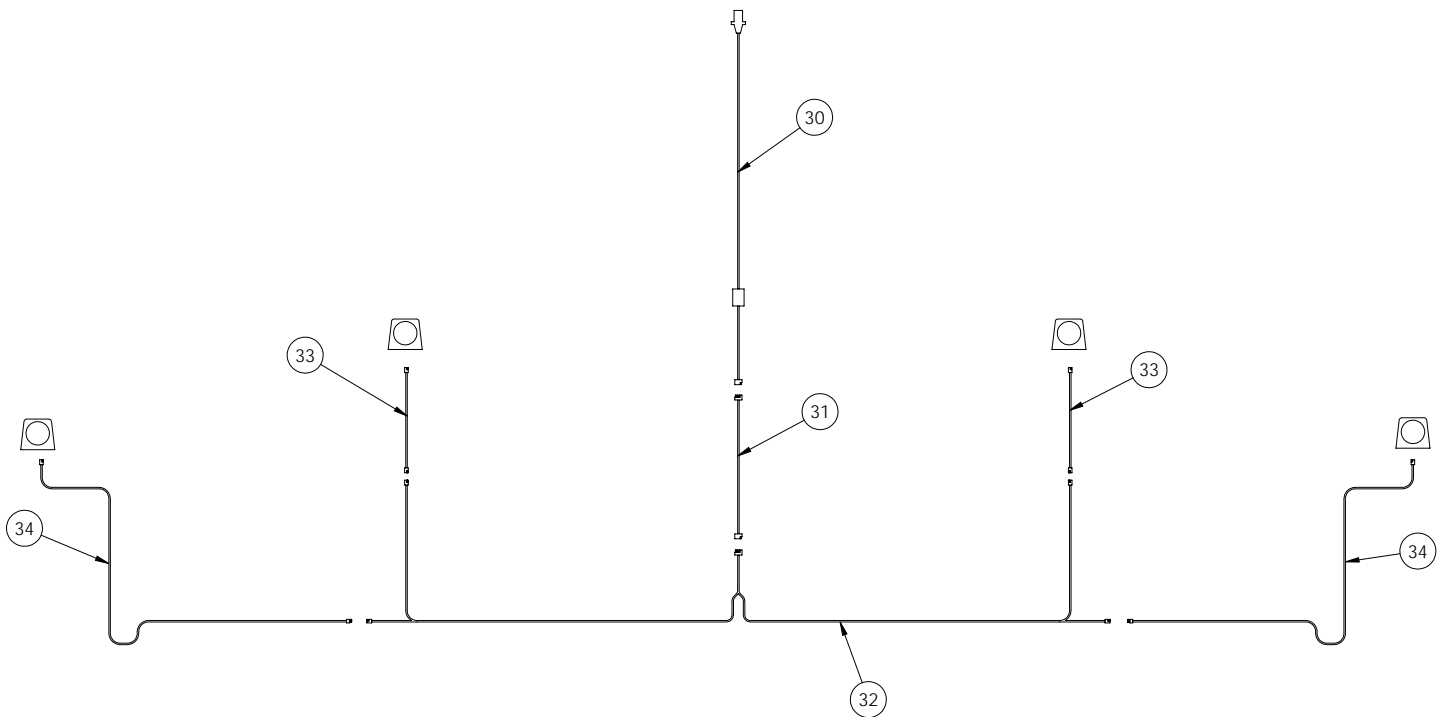

- 30. 154-629 Module Cable 84" (Wesbar Brand)
154-682 Module Cable 192" (Wesbar Brand)
154-829 Front Module Harness 84" (Cobo Brand)
154-832 7 Pin Protective Boot (Cobo Brand) (not shown)
154-834 Replacement Module (Cobo Brand) (not shown)
- 31. 154-833 Front Harness Extension 10 foot
- 32. 154-630 Wishbone Light Cable 74" (Wesbar Brand)
154-830 Rear Wishbone Harness 74" (Cobo Brand)
- 33. 154-655 Red Light Extension Cable 13 foot (Wesbar Brand)
154-855 Red Light Extension Cable 13 foot (Cobo Brand)
- 34. 154-631 Amber Light Extension Cable 13 foot (Wesbar Brand)
154-831 Amber Light Extension Cable 13 foot (Cobo Brand)

601-999 Ag Light Package for 905 Stacker Bars (lights, cables, brackets, decals, etc.)

 **PRACTICE SAFE MAINTENANCE**

Proper maintenance is your responsibility. Maintenance neglect and/or poor maintenance practices can result in injury or death. Always use the proper tools to maintain implement.



AVOID CRUSHING. Make sure all personnel are clear of the implement. Lower implement to the ground, place tractor in park, turn off engine, and remove key.

USE BAR STANDS AND TO SUPPORT THE IMPLEMENT. Store implement on a clean, dry, and level surface. An uneven surface could cause implement to shift or fall, resulting in injury or death, as well as implement damage. Securely support all implement components that must be raised. Store implement away from human activity.



AVOID ENTANGLEMENT. Never lubricate or service implement in motion. Keep away from power driven parts when in motion. Disengage power sources prior to maintaining implement. Injury or death can result from contact with power driven parts when in motion.



AVOID CRUSHING. Do not stand between the tractor and implement when connecting or disconnecting implement. Injury or death can result from being trapped between the tractor and implement.



Escaping pressurized hydraulic fluid can penetrate skin, resulting in injury or death. Relieve hydraulic system pressure before connecting or disconnecting tractor. Use cardboard or wood, **NOT BODY PARTS**, to check for suspected hydraulic leaks. Wear protective gloves and safety glasses or goggles when working with hydraulic systems. If an accident occurs, see a doctor immediately for proper treatment.

⚠ PRACTICE SAFE MAINTENANCE



Never operate a combustion engine in an enclosed area. Make sure there is adequate ventilation. Exhaust fumes can cause asphyxiation.



Be extremely careful working around unshielded sharp edges. Injury may result from contact with sharp edges.

Keep all parts in good condition and properly installed. Replace damaged or missing parts immediately.

Remove tools and unused parts prior to implement operation.

LUBRICATION



Grease-eight zerks total per 905 toolbar.

Grease - use a high quality multi-purpose grease.

Follow recommended hourly service interval illustrated below.

Grease more frequently dependent upon frequency of wing stacking.

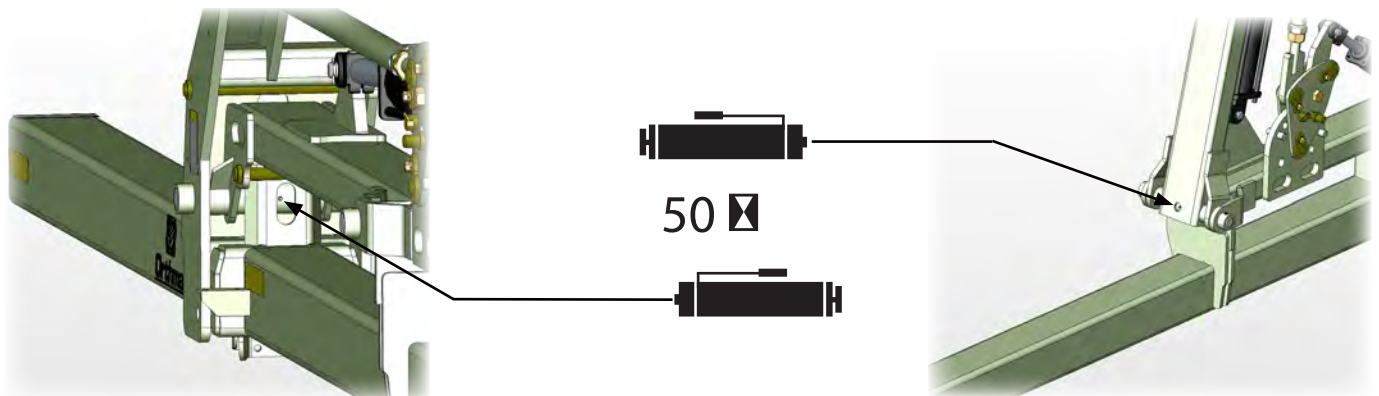

 **IMPLEMENT INSPECTION**



When replacement parts are necessary for periodic maintenance and servicing, genuine factory replacement parts must be used to restore implement to original specifications. Replace broken or worn parts immediately. Contact your Orthman dealer for replacement parts.

During break-in (40 hours) frequently (10 hours) check hardware for proper torque. (pg. 8 - 4)



Before each use, check hardware for wear and proper torque. (pg. 8 - 4) Replace damaged or missing hardware with hardware of an identical grade to restore implement to original specifications.

Do not allow debris to build up on any surface of the implement.

Replace all shields and guards. Be sure all tools, parts, and service equipment are removed prior to operating implement.

 **IMPLEMENT STORAGE**

Clean and touch up paint seasonally to avoid corrosion and rust. Contact your Orthman dealer for touch up paint.

Inspect all safety and Orthman decals and replace if missing or damaged. Contact your Orthman dealer for replacement decals. (pg. 2-7, 2-8)

Grease all zerks regardless of hourly interval prior to storage. (pg. 8-2)



Check all hardware according to torque specifications prior to storage. (pg. 8-4)

Replace all worn or damaged parts prior to storage.

Store inside if possible. Storing implement inside will prolong the life of the 905 Stacker Bar components.

AVOID CRUSHING Make sure all personnel are clear of the implement. Lower implement to the ground, place tractor in park, turn off engine, and remove key.



USE BAR STANDS TO SUPPORT THE IMPLEMENT. Store implement on a clean, dry, and level surface. An uneven surface could cause implement to shift or fall, resulting in injury or death, as well as implement damage. Securely support all implement components that must be raised. Store implement away from human activity.

TORQUE SPECIFICATIONS

RECOMMENDED DRY BOLT TORQUE

SAE GRADE 5

Bolt Size	ft. - lb.
3/8	32
7/16	52
1/2	80
9/16	115
5/8	160
3/4	280
7/8	455
1	680
1 1/8	850
1 1/4	1200

SAE GRADE 8

Bolt Size	ft. - lb.
3/8	36
7/16	59
1/2	88
9/16	130
5/8	175
3/4	315
7/8	510
1	760
1 1/8	1075
1 1/4	1500

NOTES:

NOTES:

NOTES: