



**Row Crop Tillage Toolbar
Operators Manual**

Part #125-020-01



The Orthman *Row Crop Tillage Toolbar* is the leading folding toolbar in the row crop tillage industry, designed and built to simply withstand the roughest of field conditions. The *Row Crop Tillage Toolbar* is designed to have the strength necessary to handle today's higher horsepower tractors. Dual tubing frame design leading to a double, line-bored hinge, prepares this toolbar for virtually any field condition.

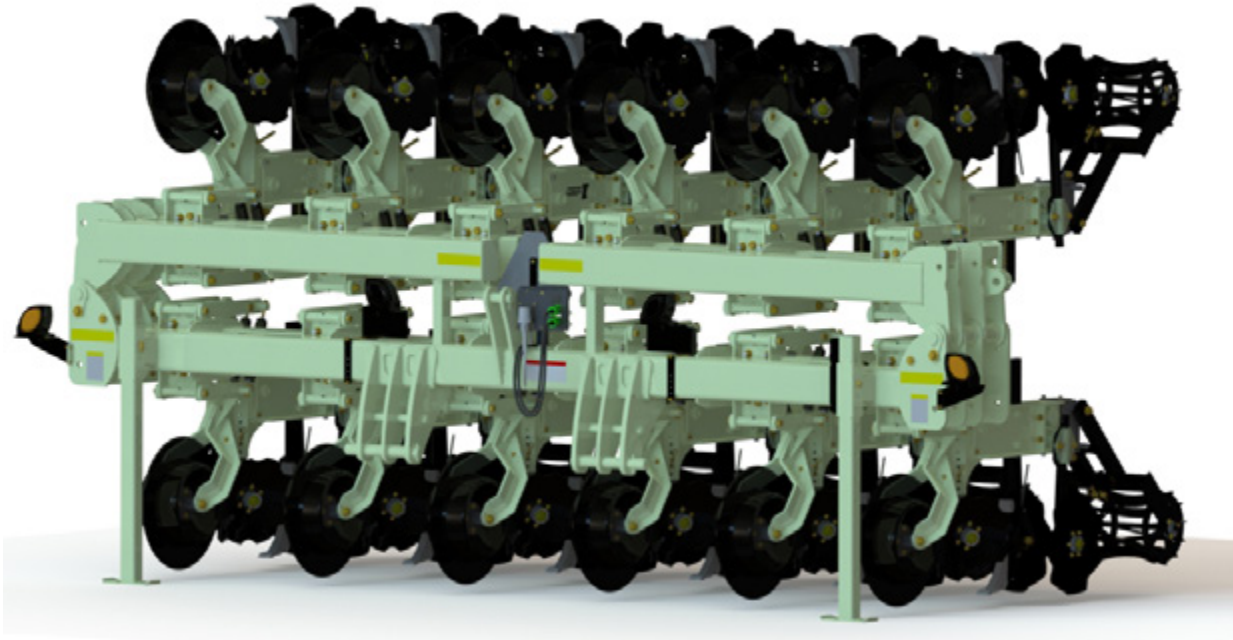

1tRIPr® on a Row Crop Tillage Toolbar

Smaller toolbar configurations will feature 5" x 7" x 1/2" wall front bar and 7" x 7" x 3/8" wall rear bar, 180 degree fold, Category 3 or Category 4 high lift three point hitch and two 4" x 24" internal fold cylinders. Larger toolbars feature 7" x 7" x 1/2" wall front and rear bar, 170 or 180 degree fold, Category 4 high lift three point hitch and four 4" x 24" internal fold cylinders with hydraulic manifold. The largest of toolbars will introduce a top truss feature. All bars feature integrated bar stands, wing rests, hydraulic hose and light connector storage, safety lighting & decals.

This manual is considered to be an integral component of the *Row Crop Tillage Toolbar* and is designed to educate the owner and/or operator(s) regarding safety, operation, maintenance, troubleshooting, and component identification. All personnel involved in the operation of this implement are responsible for reading and understanding entire manual content.

This manual is designed to keep the operator safe and knowledgeable as well as prolong the life of the implement and maximize field efficiency. This manual should accompany the implement if it were ever to be sold.

We would like to thank you for placing your confidence in Orthman Mfg., Inc. Your *1tRIPr*® is manufactured to meet the highest standards and is built with precision and strength to increase your agricultural operation's dependability and profitability.

Thank you for choosing Orthman.

INTRODUCTION

To The Dealer:

Inspect the implement thoroughly after assembly to be certain it is functioning properly before delivering it to the customer. The following checklist is a reminder of points to cover. Check off each item as it is found satisfactory or after proper adjustment is made.

Pre-Delivery Checklist

- 1. All Hardware properly tightened.
- 2. Lubrication of grease fittings.
- 3. All decals properly located and readable.
- 4. All implement tools and options are installed and set.
- 5. Check overall condition of implement.
- 6. Make sure Operator's manual is included.

Date Set Up. _____ Signature. _____

Delivery

Review the operator's manual with the customer. Explain the following:

1. Introduce the machine to the customer. Give the customer this manual and encourage them to read it.
2. Make the customer aware of all the safety precautions that must be exercised when using and transporting this machine.
3. Make customer aware of the different tooling options available.
4. This machine does not come set to run in the field from the factory. The Field settings section in this manual is meant to help set the machine for optimal performance. Explain all operating adjustments.
5. Explain to the customer that the life expectancy of this machine depends on regular maintenance as directed in this manual.
6. Tell the customer to use the proper tools for service and make them aware of Orthman parts availability.
7. Write machine model number and serial number in the spaces provided below.

Date delivered. _____ Signature. _____

Model Number. _____

Serial Number. _____

INTRODUCTION

WARRANTY

Orthman Mfg., Inc. warrants the whole goods products it manufactures to be free from defects in material or workmanship for a period of one (1) year from the date of sale of the product(s) to the original user. Products not manufactured, but supplied by Orthman Mfg., Inc. on Orthman products, are subject to, conform with, and are limited to the warranty of our suppliers.

Orthman Mfg., Inc. warrants the parts it manufactures to be free from defects in material or workmanship for a period of ninety (90) days from the date of delivery of the product(s) to the original user. Products not manufactured, but supplied by Orthman Mfg., Inc. on Orthman products, are subject to, conform with, and are limited to the warranty of our suppliers.

Warranty of Orthman whole goods and/or parts applies only to material and workmanship. Misuse, misapplication, neglect, alteration, accident, normal wear, or acts of God affecting Orthman products are not eligible for warranty.

Warranty of serial numbered goods will only be considered if the product has a completed Warranty Registration on file at Orthman. This Warranty Registration must be completed and returned to Orthman within thirty (30) days of the sale of the product(s) to the original user. *No serial numbered goods or related parts and/or labor will be warranted without a Warranty Registration on file.* Warranty issues falling within the first thirty days of a product's use will be handled at the discretion of Orthman. Warranty of parts will not require a Warranty Registration, but proof of date of delivery of the product to the original customer must be provided.

WARRANTY CLAIMS: A warranty claim and request to return defective product(s) must be presented to the Orthman Service Department by the selling dealer describing the defect in material or workmanship of an Orthman product(s) within ten (10) days of its discovery. This claim may be made via phone, e-mail, fax, or written request. Claims for warranty of serial numbered goods must include the Orthman product serial number and model number. Claims for warranty of parts will not require a product serial number or model number, but must be identified by an Orthman part number. Claims for warranty of whole goods or parts must also include proof of date of sale of the product to the original customer by an Orthman dealer.

The Orthman Service Department will proceed in making a preliminary decision as to the eligibility of the claim for warranty consideration. After the Orthman Service Department deems it necessary to proceed with warranty consideration, a Return Goods Authorization (RGA) will be completed by the Orthman Service Department in conjunction with the selling dealer. Upon completion of the RGA, the defective product(s) must be returned to Orthman to ensure warranty consideration. Defective product(s) must be returned to Orthman by either the selling dealer or the customer. Customer delivery of defective product(s) must be approved by Orthman and the selling dealer prior to delivery. The defective product(s) in question must be sent, freight prepaid, within sixty (60) days of the discovery of the product(s) failure and initial warranty claim. Replacement product(s) may be sent to the selling dealer, directly to the customer, or picked up at the Orthman facility. Replacement product(s), sent directly to the customer or picked up must be approved by Orthman and the selling dealer. At the discretion of the Orthman Service Department, replacement product(s) may be sent prior to, or after, the Orthman Service Department receives the defective product(s).

*Any variation in the above procedure is at the sole discretion of the Orthman Service Department.
No products will be accepted at Orthman without all proper paperwork completed including Warranty Registration and RGA(s).
Parts returned to Orthman without proper authorization will be returned to the sender at the sender's expense.*

Orthman agrees to handle all warranty claims in a timely manner and will inform dealers of any revisions or modifications to the Orthman Warranty Policy. Eligible warranty claims will be processed by Orthman within sixty (60) days of receiving failed product(s) or a valid service or repair labor claim. Eligible warranty claims regarding returned product(s) or service and/or repair labor will be paid through a credit memo issued to the appropriate dealer's account as determined by the Orthman Service Department.

If a warranty claim is found to be ineligible for warranty coverage, the Orthman Service Department will be responsible to inform the dealer in order to determine the course of action to be taken. Orthman reserves the right to make changes in specification and design without notice and without incurring any obligations to owners of products previously sold.

© Copyright 2010
Orthman Manufacturing Inc.
Lexington, Nebraska
All rights reserved.

Orthman provides this manual without warranty of any kind, expressed or implied. This manual reflects the product at the time of publication. All information within is based upon current information on the publication date. Orthman assumes no responsibility for damages incurred due to the use of the illustrations, information, and specifications within this publication.

TABLE OF CONTENTS

INTRODUCTION

General Information - Row Crop Tillage Toolbar.....1-1
 Delivery Checklist.....1-2
 Warranty Information.....1-3
 Table of Contents.....1-4

IMPORTANT SAFETY INFORMATION

Farm Safety.....2-1
 Your Protection - Equipment Safety - Safety Alert Symbol.....2-3
 Signal Words - Shutdown and Storage.....2-4
 Safe Transport - Warning and Safety Lights.....2-5
 Safe Operation - No Riders.....2-6
 Practice Safe Maintenance.....2-7
 Practice Safe Maintenance - Prepare for Emergencies.....2-8
 Anhydrous Ammonia - Liquid Fertilizer Precautions - Safety Never Hurts.....2-9
 Safety Decals.....2-10
 Orthman Decals and Orthman Serial Tag.....2-14

PREPARATION AND SETUP

Shipping Configuration.....3-1
 Preparing the Row Crop Tillage Toolbar - Implement-to-Tractor Connection.....3-2
 Toolbar Component Identification.....3-3
 Light Kit Component Identification.....3-4
 Light and Light Bracket Assembly.....3-5
 Light Cable Assembly.....3-6
 Courtesy Pallette Assembly.....3-7
 SMV & Bracket Assembly.....3-8

TABLE OF CONTENTS

FIELD SETTINGS

Bar Stands & Folding Wings.....4-1
 Rigid Lock Pin & Wing Leveling Bolts.....4-2

TROUBLESHOOTING

Tractor will not hook-up to toolbar.....5-1
 Toolbar will not fold or unfold.....5-2
 Toolbar will not fold or unfold.....5-3
 Removal of internal cylinder assembly.....5-4
 Removal of internal cylinder assembly.....5-5
 Notes.....5-6

MAINTENANCE

Practice Safe Maintenance.....6-1
 Torque Specifications.....6-2
 Lubrication.....6-3
 Lubrication - Implement Inspection.....6-4
 Implement Storage.....6-5
 Notes.....6-6

PARTS IDENTIFICATION

Hitch Assembly (Category 3).....7-1
 Hitch Assembly (Category 4).....7-2
 Toolbar Hinge Assembly (5"x7" front bar).....7-3
 Toolbar Hinge Assembly (7"x7" front bar).....7-4
 Internal Cylinder Assembly (180 degree fold).....7-5
 Internal Cylinder Assembly (170 degree fold).....7-6
 Hydraulic Cylinder Internal Components.....7-7
 Hydraulic Manifold Assembly.....7-8
 Hydraulic Hoses and Fittings Assembly.....7-9
 Light Bracket, SMV Bracket & Courtesy Pallette Assembly.....7-10
 Light Kit Assembly - Wesbar.....7-11
 Light Kit Assembly - Cobo.....7-12

Farm Safety

Contrary to the popular image of fresh air and peaceful surroundings, a farm is not a hazard-free work setting. Every year, thousands of farm workers are injured and hundreds more die in farming accidents. According to the National Safety Council, agriculture is the most hazardous industry in the nation.

How You Can Improve Farm Safety

You can start by increasing your awareness of farming hazards and making a conscious effort to prepare for emergency situations including fires, vehicle accidents, electrical shocks from equipment and wires, and chemical exposures. Be especially alert to hazards that may affect children and the elderly. Minimize hazards by carefully selecting the products you buy to ensure that you provide good tools and equipment. Always use seat belts when operating tractors, and establish and maintain good housekeeping practices. Here are some other steps you can take to reduce illnesses and injuries on the farm:

- Read and follow instructions in equipment operator’s manuals and on product labels.
- Inspect equipment routinely for problems that may cause accidents.
- Discuss safety hazards and emergency procedures with your workers.
- Install approved rollover protective structures, protective enclosures, or protective frames on tractors.
- Make sure that guards on farm equipment are replaced after maintenance.
- Review and follow instructions in material safety data sheets (MSDSs) and on labels that come with chemical products and communicate information on these hazards to your workers.

Health and Safety Hazards on Farms

Farm workers including farm families and migrant workers are exposed to hazards such as the following:

Danger	Potential Effect or Injury	Prevention
Chemicals/Pesticides	Skin and respiratory injury or death	MSDS and proper Personal Protective Equipment. Review Manufacturers data sheets
Cold	Illness, Frostbite or death	Dress properly for the day.
Dust	Respiratory injury or explosive combinations	Be aware of your surroundings and activity
Electricity	Shock, burns, fire, death	Use a qualified professional for wiring dangerous electrical devices. Never overload a circuit. Replace damaged electrical devices or cords. Electrical tape will not insulate you from injury.
Grain bins, Silos	Entrapment, Suffocation, Explosion from formation of dangerous gases and poisoning.	Make sure the bin is properly ventilated and maintained. Never walk the grain.
Hand tools	Injury including cuts abrasions, electrocution, strains, sprains and death	Make sure you hand tools are in good condition. Never leave a damaged tooling accessible for someone else to use.
Highway traffic	Collisions resulting in injury or death	Follow regulations, stay alert. Avoid alcohol and use of communication devices while driving
Lifting & lifting devices	Back injury, sprains, strains. Falling material resulting in being struck or crushed by heavy material	Use proper lifting technique. Get help when the load is too heavy. Inspect chains, straps or cables routinely to make sure they are in good condition.
Livestock handling	Serious injury or death resulting from being pinned struck or trampled.	Always make sure you have adequate room and an escape route
Machinery/Equipment	Cuts, abrasions, amputations, death.	Thoroughly read and understand your Owners Equipment Manual. Never operate the equipment without guards in place. Make sure the equipment can not be energized or otherwise put into operation while you are working on it.
Manure pits	Explosion from formation of dangerous gases. Suffocation. Poisoning	Proper maintenance.
Mud	Sprains, strains, entrapment and suffocation. Eye injury and skin irritation.	Proper Personal Protective Equipment. In some conditions a “Spotter” may be needed.
Noise	Hearing damage	Personal Protective Equipment.
Ponds	Drowning	Wear a life preserver and make sure help is readily available.
Slips/Trips/Falls	Sprains, strains, back and neck injury, bone breaks or death	Keep work area free from clutter and organized. If working on anything elevated make sure you have appropriate guarding and/or fall protection such as a harness and lanyard.
Sun/Heat	Sun burn, Heat Stroke, shock, death	Use common sense on excessively hot days, use sun screen, wear a hat and stay hydrated.
Toxic gases	Skin and respiratory injury or death. Explosion.	MSDS and proper Personal Protective Equipment. Review Manufacturers data sheets
Tractors	Cuts, abrasions, amputations, death.	Thoroughly read and understand your Owners Equipment Manual. Never operate the equipment without guards in place. Anti-roll over devices.
Wells	Electrocution, amputation, death	Avoid contact with water while working on an electrical device. Always be sure the equipment can/will not be energized during repair or maintenance. Make sure all guarding is in place.
Severe Weather	Electrocution, “struck by” injuries, death	Move to a safe place. Lightning, hail and tornadoes are unpredictable.

Orthman Manufacturing, Inc. does not limit the potential effects or injuries nor prevention measures to those listed above. They are provided solely as a guideline to making your farm life safer. Always consult your Owner/Operators Manual for specific tool and equipment safety requirements.

High Risk Factors on Farms

The following factors may increase risk of injury or illness for farm workers:

- Age – Injury rates are highest among children age 15 and under and adults over 65.
- Equipment and Machinery – Most farm accidents and fatalities involve machinery. Proper machine guarding and doing equipment maintenance according to manufacturers’ recommendations can help prevent accidents.
- Protective Equipment – Using protective equipment, such as seat belts on tractors, and personal protective equipment (such as safety gloves, coveralls, boots, hats, aprons, goggles, face shields) could significantly reduce farming injuries.
- Take precautions to prevent entrapment and suffocation caused by unstable surfaces of grain storage bins, silos, or hoppers. Never “walk the grain.”
- Be aware that methane gas, carbon dioxide, ammonia, and hydrogen sulfide can form in unventilated grain silos and manure pits and can suffocate or poison workers or explode.
- Take advantage of safety equipment, such as bypass starter covers, power take-off master shields, and slow-moving vehicle emblems.
- Medical Care – Hospitals and emergency medical care are typically not readily accessible in rural areas near farms.

The Benefits of Improved Safety and Health Practices

Orthman Manufacturing Provides this document in the hope that everyone that has a job to do, does it SAFELY. Our goal and yours should be to end each day in the best possible health. Better safety and health practices reduce fatalities, injuries, and illnesses as well as associated costs such as workers’ compensation insurance premiums, lost production, and medical expenses. A safer and more healthful workplace improves morale and productivity.

⚠ FOR YOUR PROTECTION



READ AND UNDERSTAND THE ENTIRE CONTENT OF THIS MANUAL BEFORE OPERATING OR SERVICING IMPLEMENT. Read and understand all operator manuals for the machinery used in conjunction with your Orthman equipment.

- Carefully **READ ALL SAFETY DECALS** in this manual as well as on the implement. Keep implement clean so decals are easily visible. Keep all safety decals in good, clean, and legible condition. Immediately replace damaged and/or missing decals. Replacement decals are available from your Orthman dealer.
- Learn to operate the implement and all components properly. Do not let others operate implement without proper instruction. Unauthorized implement modifications may impair function and safety. If you do not understand any content in this manual or need assistance, contact your Orthman dealer.

⚠ EQUIPMENT SAFETY GUIDELINES

Operator safety is the primary concern when designing an Orthman implement. Orthman integrates as many safety features into the implement as possible. You can avoid many hazards and possible accidents by observing precautions in this safety section.

- Insist that yourself and personnel working with and around you follow all safety precautions. Be cautious when working with or around implement to avoid injury.

SAFETY ALERT SYMBOL



The **SAFETY ALERT SYMBOL** warns of potential hazards to personal safety and that extra precautions must be taken. When you see this symbol, carefully read the message(s) that follow. Follow all recommended precautions and safe operating practices in this manual.

NOTE: Hazard control and accident prevention are dependent upon the safety awareness and proper training of personnel involved in the operation of this implement.

⚠ BE AWARE OF SIGNAL WORDS

SIGNAL WORDS designate a degree or level of **HAZARD** seriousness. These signal words include:



RED

DANGER indicates a hazardous situation that, if not avoided, will result in death or serious injury. **DANGER** is limited to extreme situations, typically for machine components which for functional purposes, cannot be guarded.



ORANGE

WARNING indicates a potentially hazardous situation that, if not avoided, could result in death or serious injury. **WARNING** includes hazards that are exposed when safety guards are removed. Warning may also be used to alert against unsafe practices.



YELLOW

CAUTION indicates a potentially hazardous situation that, if not avoided, may result in minor or moderate injury. **CAUTION** may also be used to alert against unsafe practices.

⚠ SHUTDOWN AND STORAGE

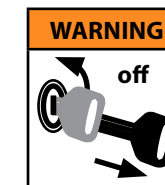

AVOID CRUSHING. Make sure all personnel are clear of the implement. Lower implement to the ground, place tractor in park, turn off engine, and remove key.



USE BAR STANDS AND CYLINDER STOPS TO SUPPORT THE IMPLEMENT.

Store implement on a clean, dry, and level surface. An uneven surface could cause implement to shift or fall, resulting in injury or death, as well as implement damage. Securely support all implement components that must be raised. Store implement away from human activity.

⚠️ SAFE TRANSPORT

- Engage transport locking devices prior to transport.
- Plan your route to avoid traffic. Yield to traffic in all situations.
- Maximum transport speed is 20 mph (32 kph). Various conditions will require reduced speed. Travel at speeds that allow for adequate control of stopping and steering.

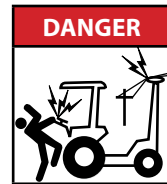

AVOID ELECTROCUTION. Be aware of overhead power lines. Contact or close proximity to power lines can result in injury or death. Use extreme care when operating implement near power lines.

- Know implement transport height and gross weight. Avoid overhead obstructions not allowing your transport height. Do not use bridges rated below combined implement and tractor weight.
- Make sure a slow moving vehicle (SMV) placard is mounted to the implement and is easily visible to other motorists.
- Make allowances for implement size when transporting. Sudden braking can cause a towed load to swerve and/or rollover. Never use independent braking with implement in tow as loss of control and/or rollover can result. Reduce speed if towed implement is not equipped with brakes.
- Do not coast. Always keep tractor or towing device in gear to provide engine braking when traveling downhill.
- Comply with state and local laws governing implement transport.

⚠️ WARNING AND SAFETY LIGHTS

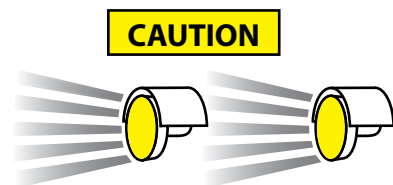

- Oversized implements and slow moving vehicles create a hazard when transported on public roads.
- Make sure all warning, safety lights, and turning signals are working and clean. Use safety lighting when using public roads day and night. Replace missing or damaged lights immediately. Comply with state and local laws governing implement safety lighting.
- A safety lighting package, conforming to implement lighting standard ANSI/SAE S279.12, if not supplied with, is available for addition to your equipment. Contact your Orthman dealer for safety lighting package information. Refer to toolbar operator's manual for safety lighting package installation and adjustment.

⚠️ SAFE OPERATION

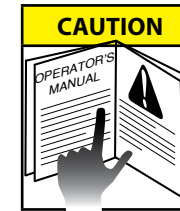

READ AND UNDERSTAND THE ENTIRE CONTENT OF THIS MANUAL BEFORE OPERATING OR SERVICING IMPLEMENT. Implement is to be operated by qualified personnel only. Never let children operate implement. A complete understanding of safety precautions, operation, and maintenance is mandatory before implement use.

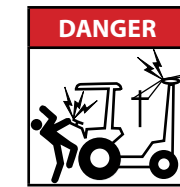

AVOID ELECTROCUTION. Be aware of overhead power lines. Contact or close proximity to power lines can result in injury or death. Use extreme care when operating implement near power lines.

- Know implement transport height and gross weight. Avoid overhead obstructions not allowing your transport height. Do not use bridges rated below combined implement and tractor weight.



AVOID ROLLOVER. Do not fold or unfold implement and avoid sharp turns when on a hillside, as shift of weight could cause rollover. Operate implement at a safe distance from terrain irregularities and other obstructions that could cause rollover.



AVOID CRUSHING. Make sure all personnel are clear of implement at all times implement is in motion. Be aware of obstructions above, below, and around implement when in operation or transport. Injury or death can result from being struck by the implement.



⚠️ NO RIDERS

NEVER ALLOW RIDERS ON TRACTOR OR IMPLEMENT. Riders hinder operator visibility and can be thrown from the implement and/or be struck by foreign objects resulting in injury or death.

⚠ PRACTICE SAFE MAINTENANCE

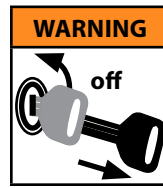

Proper maintenance is your responsibility. Maintenance neglect and/or poor maintenance practices can result in injury or death. Always use the proper tools to maintain implement.

AVOID CRUSHING. Make sure all personnel are clear of the implement. Lower implement to the ground, place tractor in park, turn off engine, and remove key.



USE BAR STANDS AND CYLINDER STOPS TO SUPPORT THE IMPLEMENT.

Store implement on a clean, dry, and level surface. An uneven surface could cause implement to shift or fall, resulting in injury or death, as well as implement damage. Securely support all implement components that must be raised. Store implement away from human activity.



AVOID ENTANGLEMENT. Never lubricate or service implement in motion. Keep away from power driven parts when in motion. Disengage power sources prior to maintaining implement. Injury or death can result from contact with power driven parts when in motion.



AVOID CRUSHING. Do not stand between the tractor and implement when connecting or disconnecting implement. Injury or death can result from being trapped between the tractor and implement.



Escaping pressurized hydraulic fluid can penetrate skin, resulting in injury or death. Relieve hydraulic system pressure before connecting or disconnecting tractor. Use cardboard or wood, **NOT BODY PARTS**, to check for suspected hydraulic leaks. Wear protective gloves and safety glasses or goggles when working with hydraulic systems. If an accident occurs, see a doctor immediately for proper treatment.

⚠ PRACTICE SAFE MAINTENANCE



- Never operate a combustion engine in an enclosed area. Make sure there is adequate ventilation. Exhaust fumes can cause asphyxiation.



- Service tires safely. Tire and rim separation can result in serious injury or death. Do not over inflate tires. Only mount or dismount tires if you possess the proper equipment, otherwise contact a trained professional. Always maintain correct tire pressure. Inspect tires and wheels daily. Do not operate tires with inadequate pressure, cuts, visible damage, or missing hardware.



- Be extremely careful working around unshielded sharp edges. Injury may result from contact with sharp edges.

- Keep all parts in good condition and properly installed. Replace damaged or missing parts immediately.

- Remove tools and unused parts prior to implement operation.

⚠ PREPARE FOR EMERGENCIES

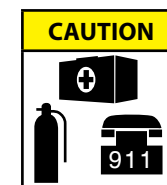

- Be prepared for a fire. Keep a readily accessible fire extinguisher at all times.

- Keep a readily accessible stocked first aid kit and emergency phone numbers for your doctor, hospital, ambulance, and fire department.

- Wear protective clothing and equipment. Wear clothing appropriate for the situation. Protect your eyes, ears, hands, and feet with the use of protective goggles, ear plugs, gloves, boots, etc.

⚠ ANHYDROUS AMMONIA - NH₃ LIQUID FERTILIZER



ANHYDROUS AMMONIA (NH₃) AND LIQUID FERTILIZER APPEARS HARMLESS. DIRECT EXPOSURE TO NH₃ OR LIQUID FERTILIZER IS EXTREMELY DANGEROUS AND CAN RESULT IN INJURY AND/OR DEATH.

- Keep a clean supply of water readily accessible in case of exposure to NH₃ or liquid fertilizer.
- Wear protective goggles and gloves when working with NH₃ or liquid fertilizer. Be sure all persons involved in the operation are properly trained concerning the dangers and precautions involved in the application of NH₃ or liquid fertilizer.
- If you choose to apply NH₃ or liquid fertilizer, it is advisable to consult documented information regarding safe handling and application of NH₃ or liquid fertilizer. Information is available from the following recognized sources:

1. American National Standards Institute - www.ansi.org - (212) 642-4900
2. Material Safety Data Sheets - MSDS - www.msdsonline.com
3. National Safety Council - www.nsc.org/necas
4. The Fertilizer Institute - www.tfi.org
5. United States Department of Transportation - D.O.T. - www.dot.gov
6. Compressed Gas Association - www.cganet.com

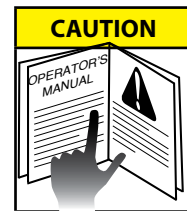

⚠ SAFETY NEVER HURTS

READ AND UNDERSTAND THE ENTIRE CONTENT OF THIS MANUAL BEFORE OPERATING OR SERVICING IMPLEMENT.

- Understand all implement functions.
- Never stand between tractor and implement when connecting or disconnecting implement.
- Be aware of all surroundings before moving implement.
- Operate implement from operator's seat only.
- Never mount or dismount a moving tractor.
- Never leave engine running when implement is unattended.
- Keep away from power driven parts when in motion.
- Make sure all personnel are clear before lowering implement to the ground.

SAFETY DECALS

Safety decals promote awareness and knowledge concerning safe operation and maintenance of the implement.

Carefully **READ ALL SAFETY DECALS** in this manual as well as on the implement. Keep implement clean so decals are easily visible. Keep all decals in good and legible condition. Immediately replace damaged and/or missing decals. Replacement decals are available from your Orthman dealer.

To install decals: Thoroughly clean area where decal is to be placed and attach decal void of bubbles. Refer to this safety information section for proper decal placement.



RED



ORANGE



YELLOW



(manual enclosure)

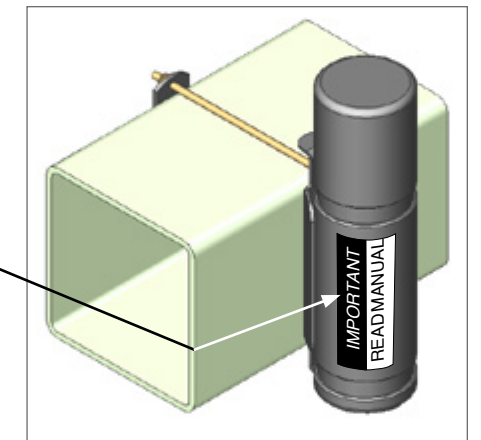

(end of wing)

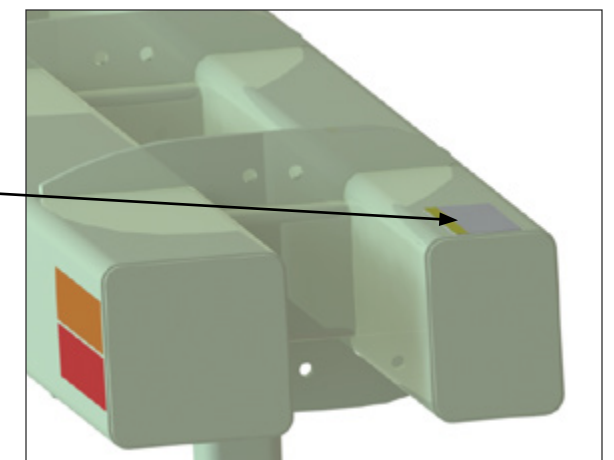

SAFETY DECALS

WARNING

1. Stay clear of wing sections when raising and lowering.
2. Engage all transport locking devices prior to transport. (see operator's manual)
3. Use extreme caution when in transport. Be aware of overhead power lines and any other obstructions.
4. Reduce speed as raised implement reduces tractor maneuverability.

153-013

(front of hinge)

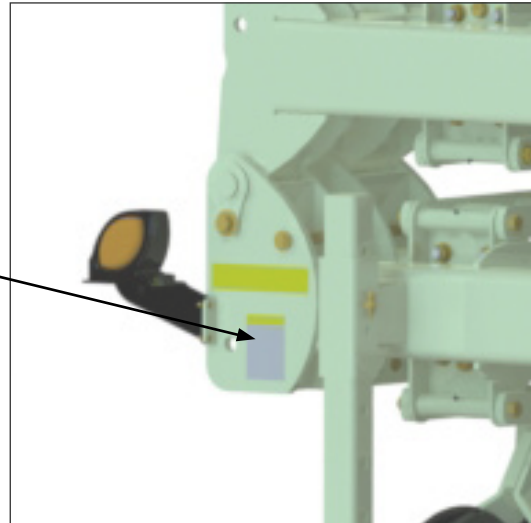

	<p>! DANGER</p>
	<p>HIGH-PRESSURE FLUID HAZARD</p> <p>To prevent serious injury or death:</p> <ul style="list-style-type: none"> • Relieve pressure on hydraulic system before servicing or disconnecting hoses. • Wear proper hand and eye protection when searching for leaks. Use wood or cardboard instead of hands. • Keep all components in good repair. <p style="text-align: right; font-size: small;">153-528</p>

(front center of bar)

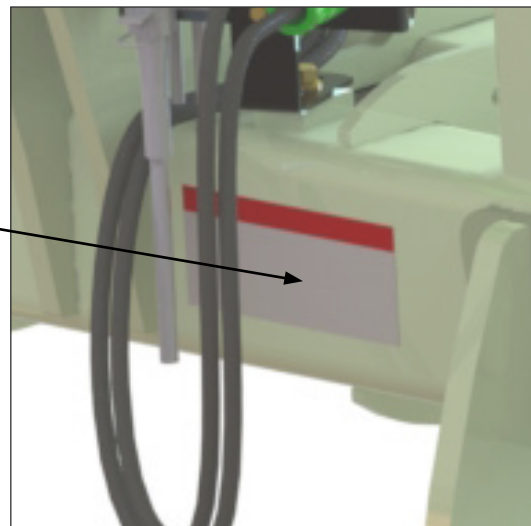

SAFETY DECALS

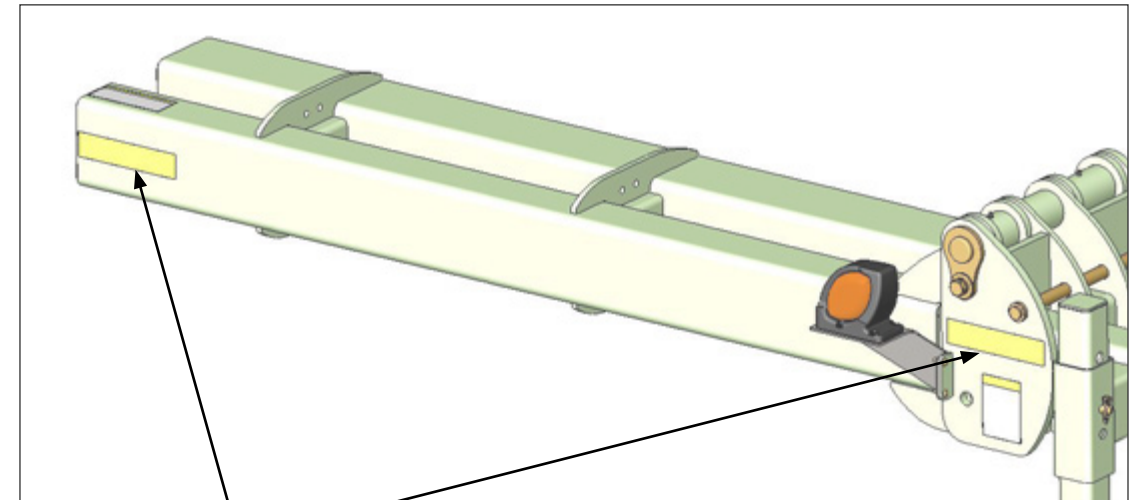

153-172
Amber Retro-reflective

(front of toolbar on end of wing, and on end of center section)

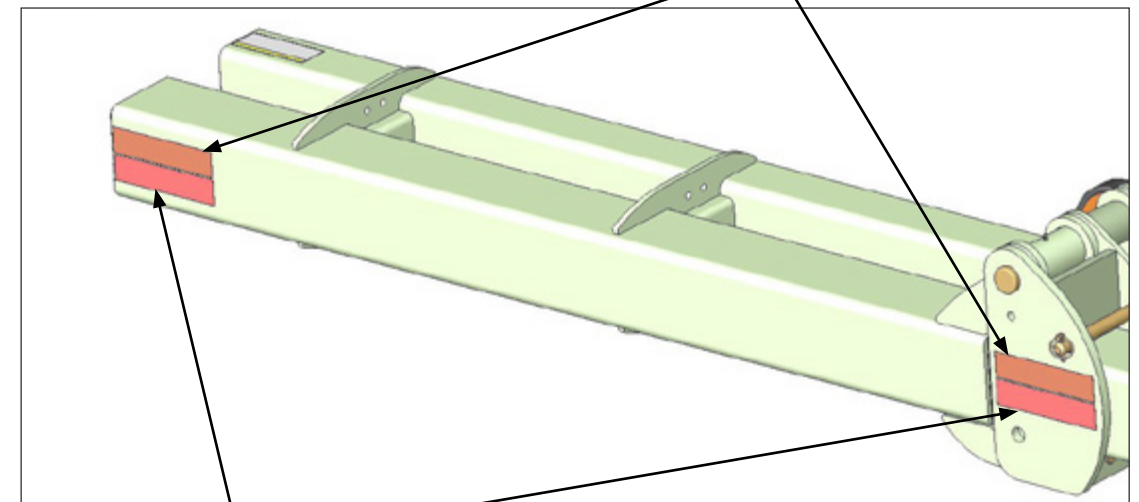

153-173
Red Retro-reflective

(rear of toolbar on end of wing, and on end of center section)

153-171
Orange Florescent

SAFETY DECALS

153-171
Orange Florescent

153-173
Red Retro-reflective

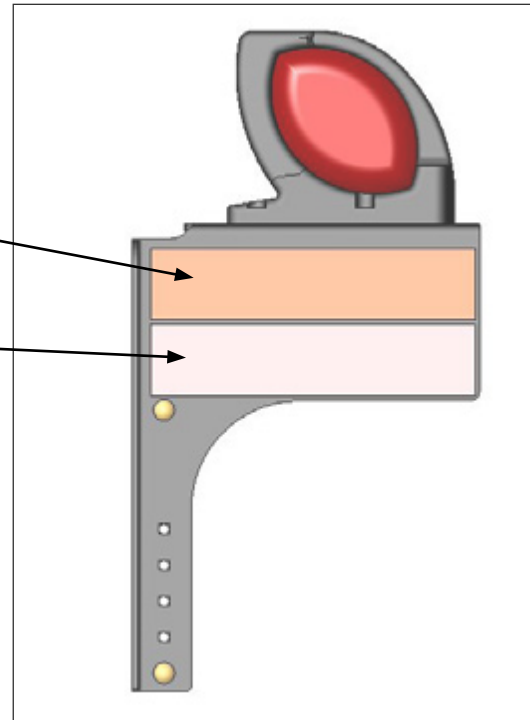

(inside red light brackets)

153-173
Red Retro-reflective

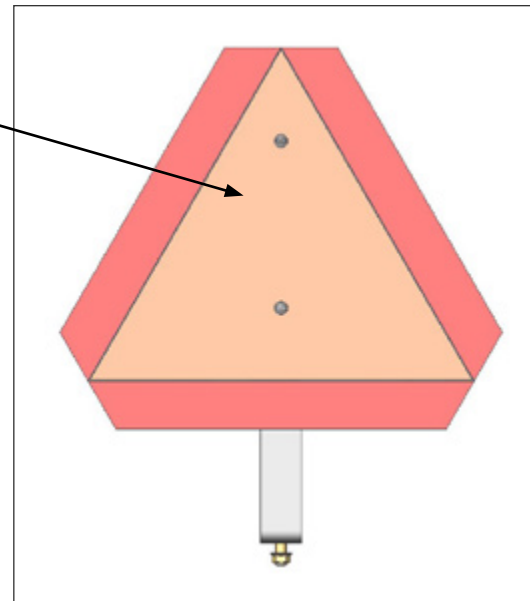

(SMV sign and bracket)

ORTHMAN DECALS

ORTHMAN
(front right and rear left of toolbar) 153-430

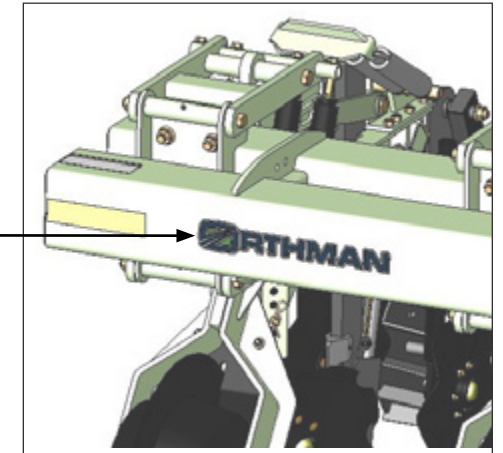

ORTHMAN SERIAL TAG

The Orthman serial tag contains valuable information. The model and serial numbers provide Orthman dealers and the Orthman Service Department with the exact specifications of your implement if any warranty or service issues need to be addressed.



153-011

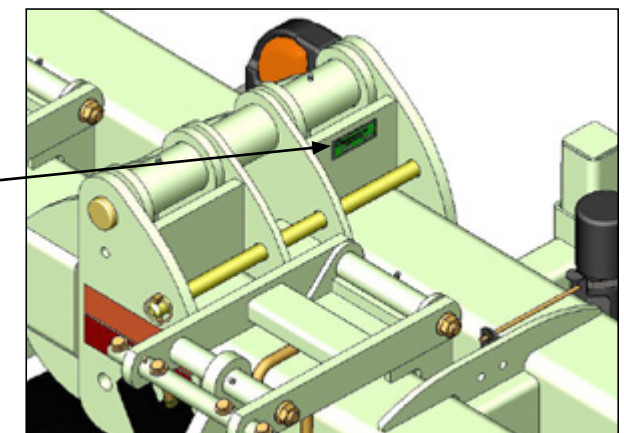

SHIPPING CONFIGURATION

The majority of the *Row Crop Tillage Toolbar* is assembled at Orthman Mfg., Inc. The *Row Crop Tillage Toolbar* is assembled in an appropriate shipping configuration to ensure transport safety and efficiency from the manufacturer.

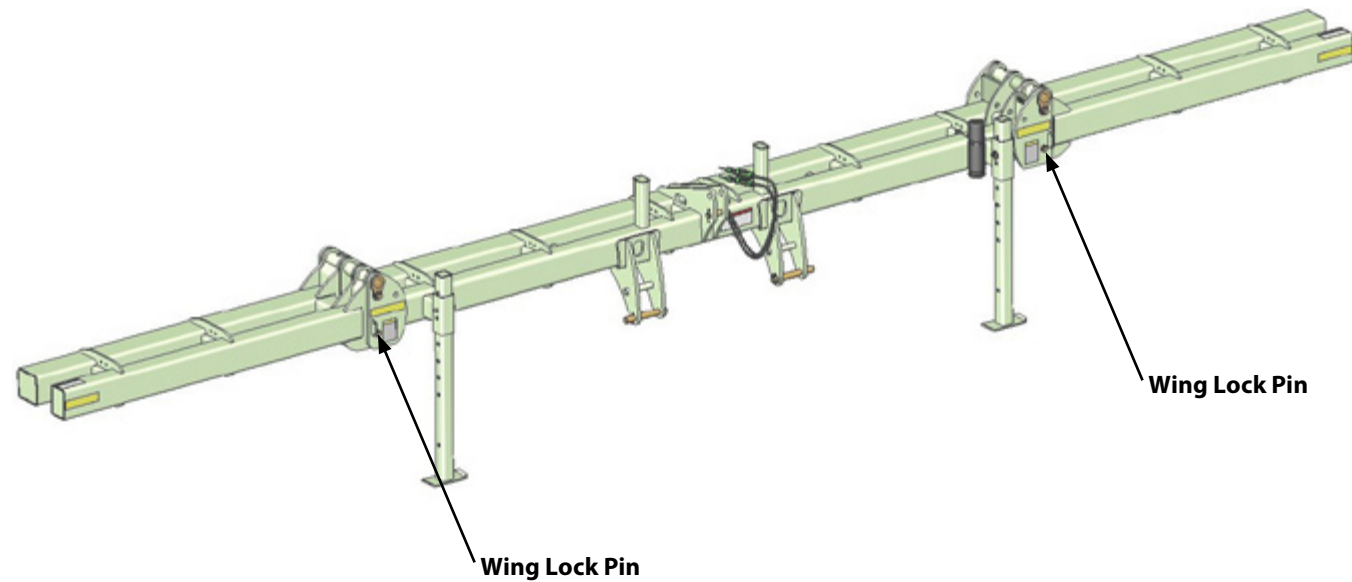

CAUTION
 Be extremely careful working around unshielded sharp edges. Injury may result from contact with sharp edges.
 153 - 045

The *Row Crop Tillage Toolbar* may ship folded or unfolded, depending on configurations. If the toolbar ships unfolded (shown picture above) it will most likely have the rigid wing lock pins installed. These pins will need to be removed prior to folding the toolbar. (see pg. 4 - 1)

The *Row Crop Tillage Toolbar* will also come from the factory without the safety lights, hydraulic storage plate, or the SMV installed, due to the potential for damage to those items during shipment. These items will also need to be installed prior to use or transport of the *Row Crop Tillage Toolbar*.



PREPARING THE TOOLBAR

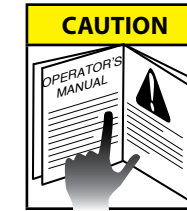

Tooling options available for added *Row Crop Tillage Toolbar* versatility are illustrated and explained in the tooling options section of this manual. Field adjustments are illustrated and explained in the field settings section of this manual.

If an Orthman row unit is used in conjunction with the *Row Crop Tillage Toolbar*, be sure to consult the row unit operator's manual before attempting to operate the implement. Read and understand operator manuals for machinery used in conjunction with the *Row Crop Tillage Toolbar*.



Before each use, check hardware for wear and proper torque. Replace damaged or missing hardware with hardware of an identical grade to restore implement to original specifications.

IMPLEMENT TO TRACTOR CONNECTION



AVOID CRUSHING. Do not stand between tractor and implement when connecting or disconnecting implement. Injury or death can result from being trapped between the tractor and implement.

AVOID CRUSHING. Make sure all personnel are clear of the implement. Lower implement to the ground, place tractor in park, turn off engine, and remove key.



USE BAR STANDS TO SUPPORT THE IMPLEMENT. Park implement on a clean, dry, and level surface. An uneven surface could cause implement to shift or fall, resulting in injury or death, as well as implement damage. Securely support all implement components that must be raised.

**TOOLBAR
COMPONENT IDENTIFICATION**

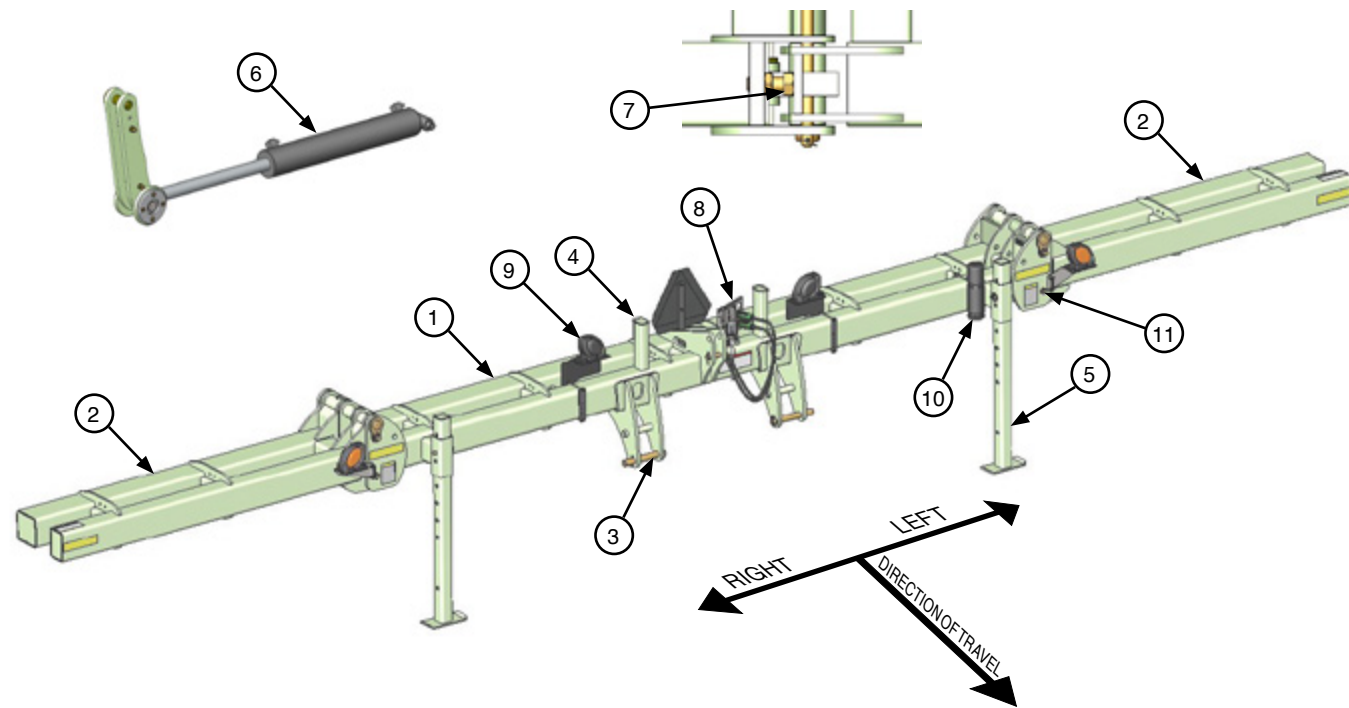

NOTE: Right and left as illustrated above and referenced from this point on, is determined by facing the same direction the toolbar will travel while in use.

- 1. CENTER SECTION.** A solid, heavy-duty center section provides a robust toolbar foundation.
- 2. WINGS.** Dual tube wings provide strength to the very end of the toolbar.
- 3. THREE POINT HITCH.** Securely welded to the center section, the three point hitch comes in two options: "CAT 3" (shown above) accommodates ASAE category 3 and 3N quick couplers. The "CAT 4" option will accommodate ASAE category 4 and 4N quick couplers.
- 4. WING RESTS.** 180 degree, welded on wing rests for most toolbars. Longer 170 degree, welded on rests for toolbars used in certain larger applications.
- 5. BAR STANDS.** The row unit mainframe serves as the primary mount for row unit tooling.
- 6. INTERNAL CYLINDER ASSEMBLY.** Orthman developed the internal fold cylinder many years ago and it continues to be a trademark feature of our toolbars. Some larger toolbars will utilize two cylinder assemblies to fold each wing, tied together with a hydraulic manifold.
- 7. WING LEVEL BOLTS.** These bolts server as the down-stop for the wing and can be fine-tuned to accurately level the bar when unfolded.
- 8. COURTESY PALLETTE.** This handy storage plate is a place to safely and neatly store the bar hydraulic hoses and 7 pin connector for the lights. It also houses the logic module for the light assembly, and can have additional hose storage plates added to it.
- 9. SAFETY LIGHTS AND SMV.** The safety light and SMV package are boxed up and will need to be assembled prior to use of the toolbar.
- 10. MANUAL STORAGE TUBE.** A place to safely store this manual, and will also house the manual for any row unit that is on the toolbar if you purchased a full machine.
- 11. RIGID WING LOCK PIN.** Use this pin to lock down the toolbar to a rigid machine. When not in use, storage for this pins are at the end of the center section right near the hinge pin.

LIGHT KIT

An un-assembled light kit will come with your *Row Crop Tillage Toolbar*. The light kit will come in a box that has Orthman manufactured components in it, as well as an ag light kit from Wesbar or Cobo light companies. Orthman mounting and storage brackets will accommodate either brand, however cable and light components are not interchangeable between the two brands. Below is an example of what will typically be found in a light kit.

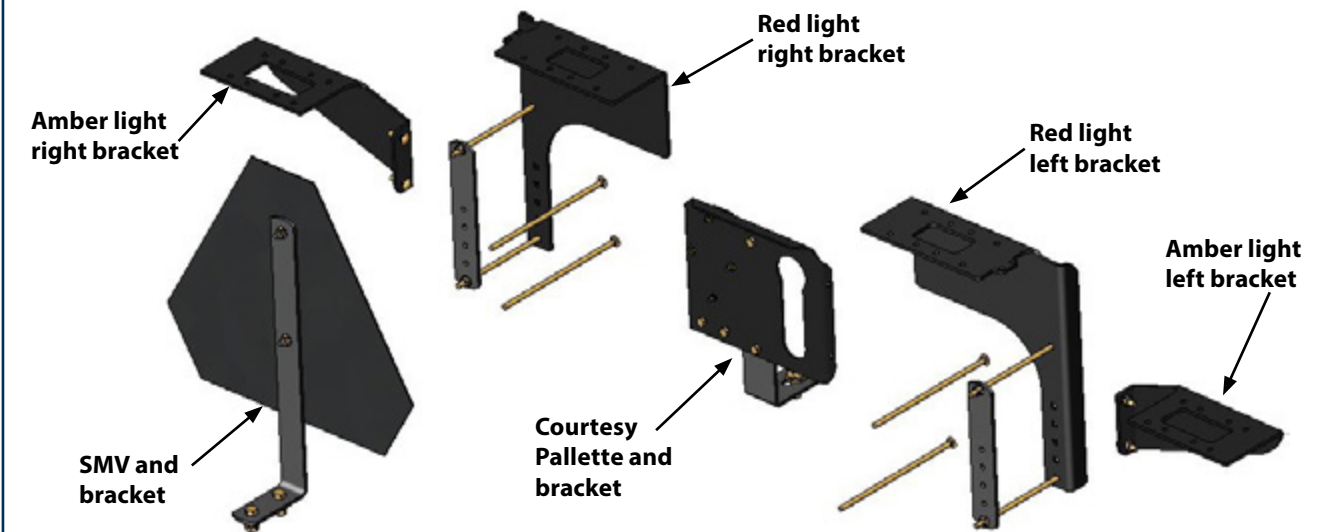

PREPARATION AND SETUP

LIGHT & LIGHT BRACKET ASSEMBLY

Mount left and right light mounting brackets to light mount tabs located at the end of the center section. (shown below) Use the provided 1/4" x 1" carriage bolts and flange nuts to mount each bracket to the toolbar. Mount Amber (orange) colored lights to the bracket with the hardware provided in the light kit. Light bracket is universal and should work with both brands of lights available. Cable lead on light should be able to be strung thru rectangle hole in light brackets. Amber lights will have lenses in front and back and should be visible from the front and back when toolbar is completely folded.

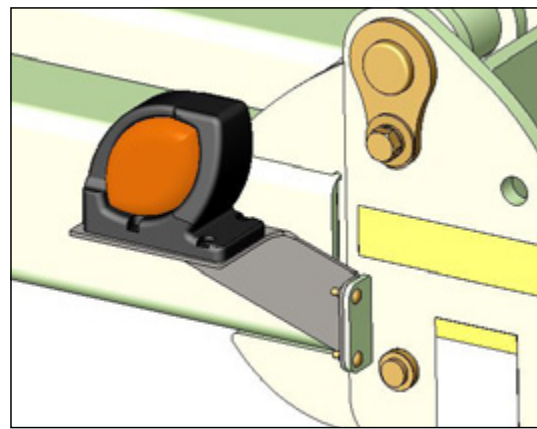

Right amber light

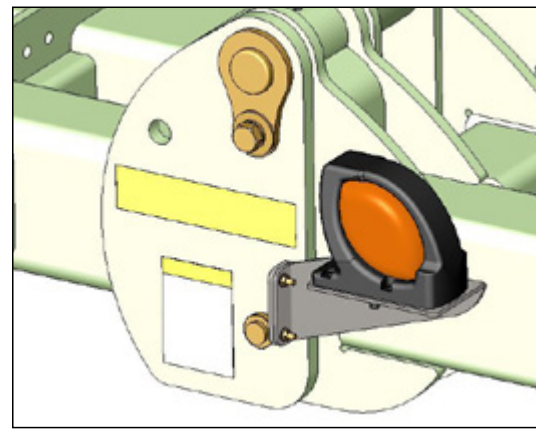

Left amber light

Mount center red light brackets as shown below. Two different lengths of carriage bolts are provided in the light kit. A 1/4" x 6" carriage bolt for toolbars with 5"x7" front bars and a 1/4" x 8" carriage bolt for 7"x7" front bar toolbars. Lights must each be mounted equally from the center of the bar and be a total distance between 4 feet and 10 feet from each other.

Mount the red lights and string light cable thru rectangle hole in bracket. If lights are Cobo brand, there will be a left and right version of the red light due to the design. Red lights will only have a lense on one side of the light, and it should be visible from the rear of the bar (like tail-lights) and not the front. Use the hardware provided in the ag light kit to mount the lights to the brackets.

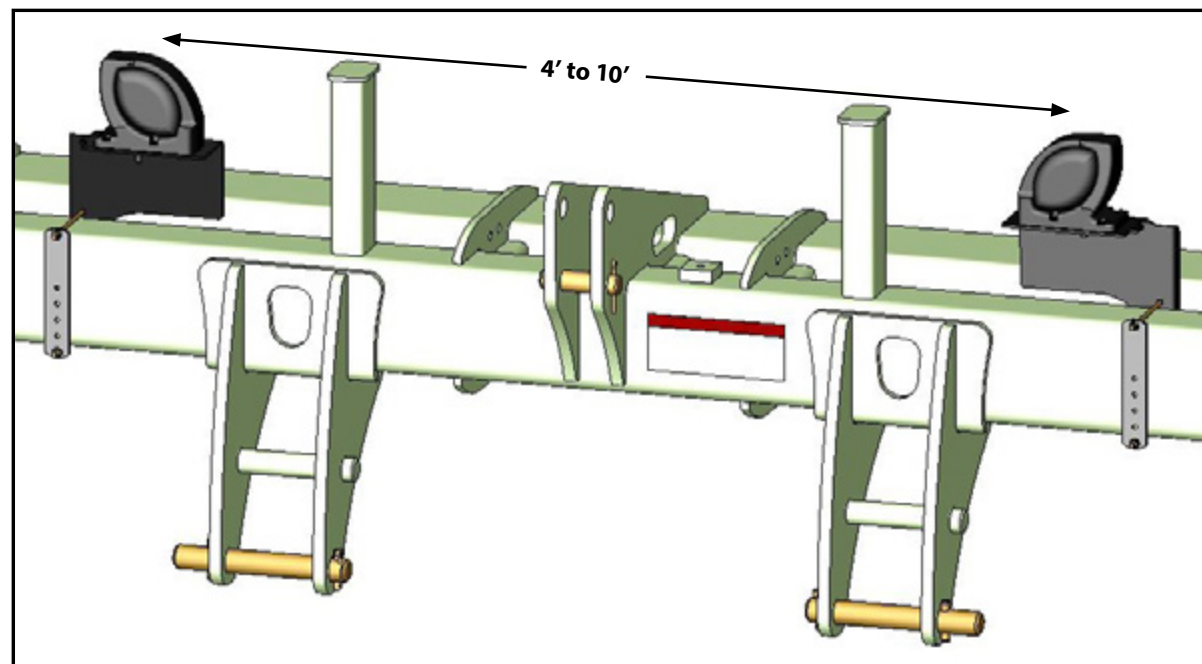

Center red lights

PREPARATION AND SETUP

LIGHT CABLE ASSEMBLY

Once lights are mounted, cables can be strung. Start in the center with the main wishbone harness. This cable will have one end that plugs into the front logic module harness, and 4 ends that will lead to the lights. On the Wesbar brand lights the ends with the heat shrink on the main wishbone harness will lead out to the amber lights. Most toolbar configurations will need to utilize the extension cable to be able to reach out to the amber lights. The extension cable will plug into the end of the main wishbone harness and then into the lead at the end of the amber lights. The other 2 leads will go to the left and right red lights. Cable ties (zip ties) are provided to help secure the cables to the toolbar. It is important to neatly organize cables and securely fasten them all down so they do not catch or become entangled with crops or crop residue and pulled from the toolbar.

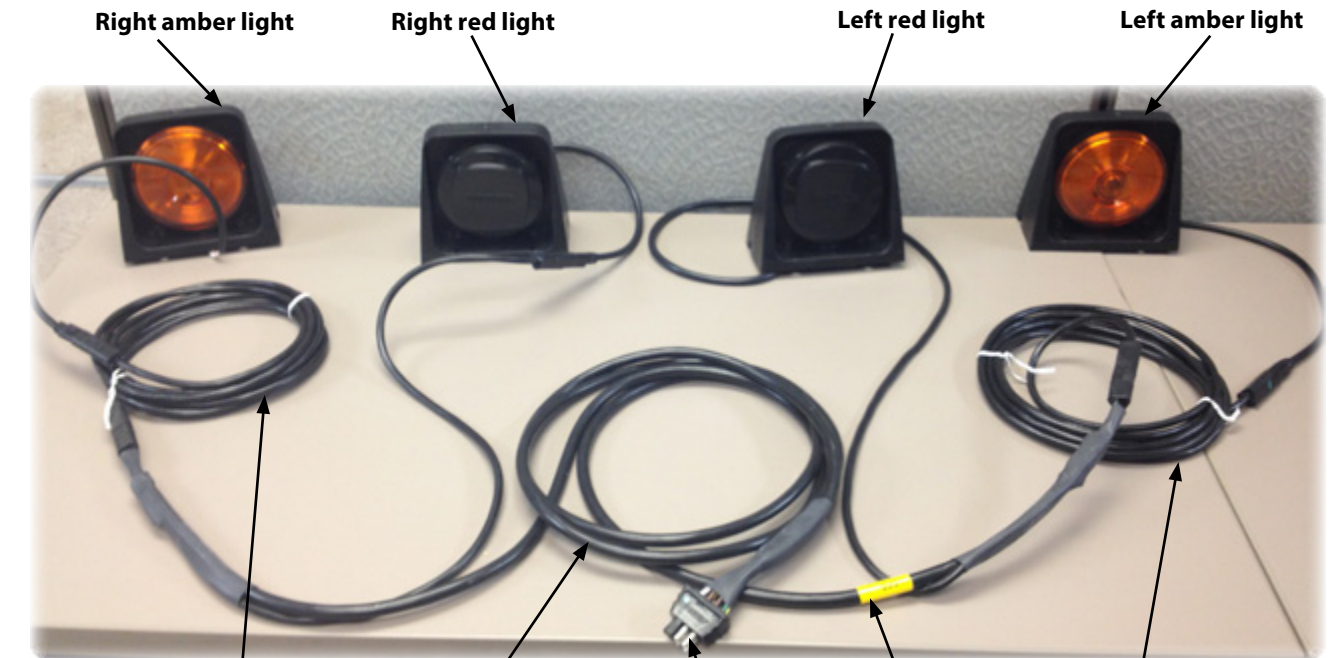

Extension cable

Main wishbone harness

Connector to Front logic module harness

Left sticker

Extension cable

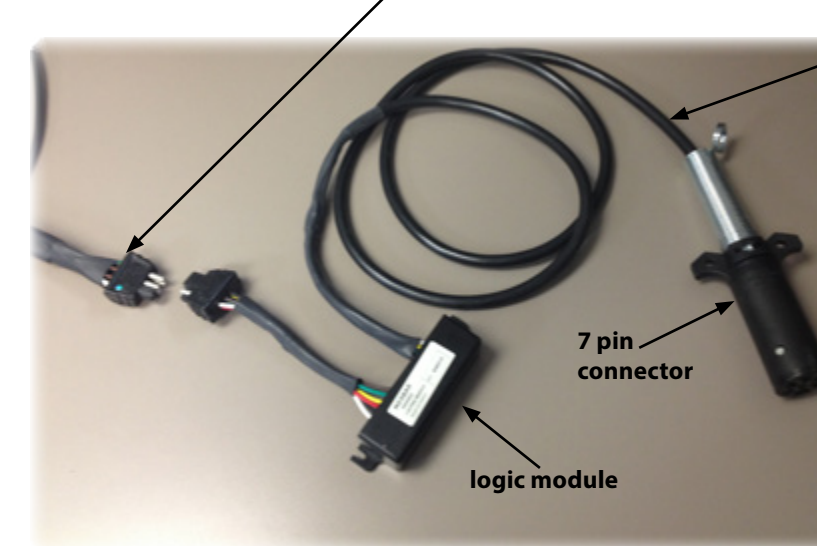

Front logic module harness

7 pin connector

logic module

The main wishbone harness will have a connector that will then plug into the front logic module harness. The front logic module harness is the cable that will go to the tractor. The 7 pin connector will plug into the tractor. The logic module will be able to be mounted to the courtesy palette. (see pg. 3-7)

COURTESY PALETTE ASSEMBLY

Orthman has developed a courtesy palette for convenient storage of hydraulic hose ends, 7 pin light/tractor connector and mounting of light cable logic module. The *Row Crop Tillage Toolbar* will have a mounting tab welded just to the left of the hitch center mast. This tab has a 1/2" tapped hole in it. Use the 1/2" x 1 1/4" bolt, flat washer and lock washer to mount the courtesy palette mount to the bar. The slotted hole should give adjustment to angle the palette for easy access. Mount the palette plate to the mounting bracket with the 1/4" x 3/4" long bolts and 1/4" nuts provided.

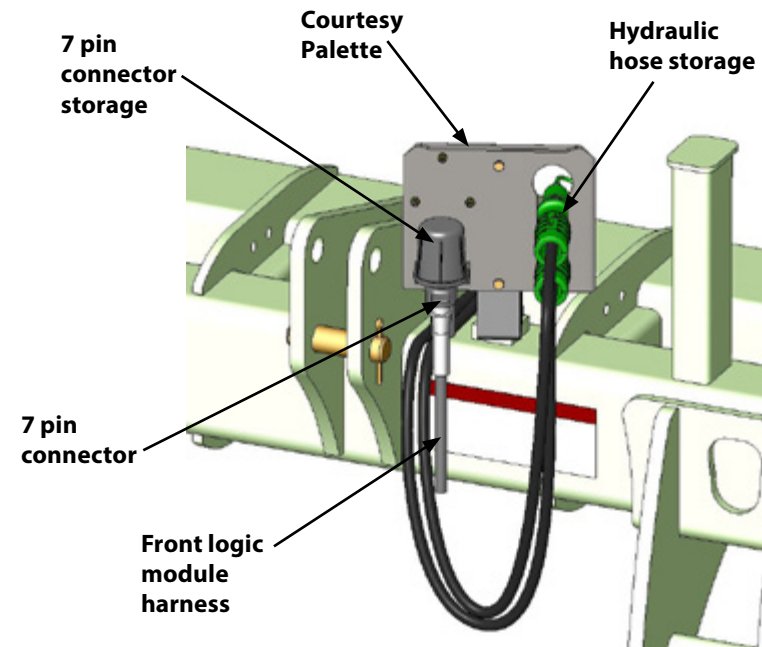

Fit hydraulic hose grips thru the larger opening at the top of the storage slot and slide them down for safe storage. The base model of courtesy palette comes with one hydraulic storage slot that can accommodate 2 hydraulic hoses. Optional additional "add a slot" storage plates can be added to the ends of the courtesy palette. With the hardware provided, mount the 7 pin connector storage plug. It should be mounted so that the 7 pin comes up from the bottom and plugs in to protect from moisture. To plug in the connector, push in the 7 pin from the bottom and it will depress a spring loaded stop, once in turn the 7 pin to secure.

On the rear of the courtesy palette (images below) there is a place to mount the logic module that is part of the Front logic module harness. Use the machine screws and nuts provided to mount either the Wesbar or Cobo logic module. It is important to protect this module as it contains valuable programming that help the lights perform flashing and turn signal functions.

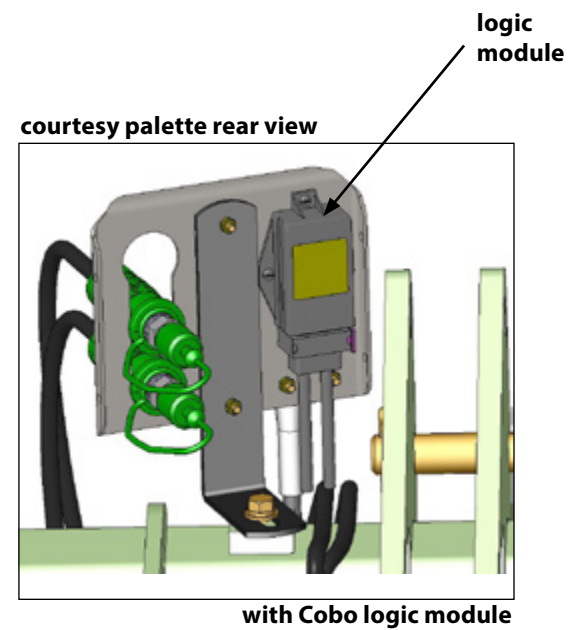
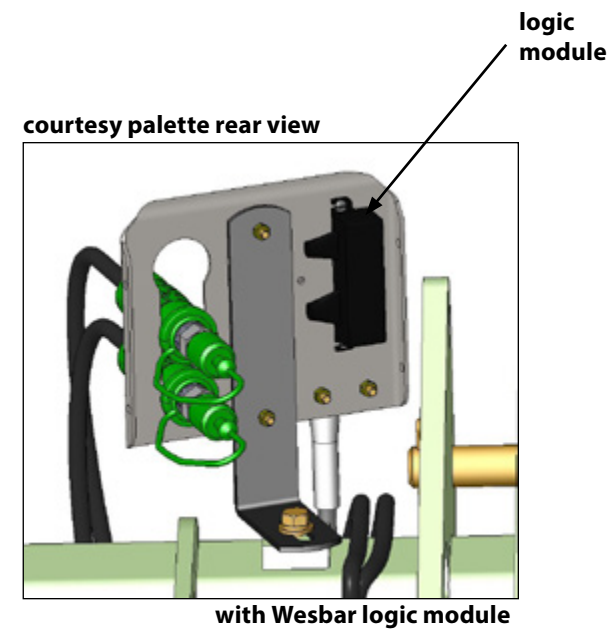

SMV SIGN ASSEMBLY

The final item that the light kit contains is the SMV (slow moving vehicle) mount and sign. The SMV is mounted at the center of the *Row Crop Tillage Toolbar* with a two bolt mounting bracket. Use the two 3/8" x 1" long bolts to mount the bracket to the two holes in the center of the channel that separates the front bar from the rear bar (top image) or the small bracket with 2 holes welded in-between the center mast plates (lower image). The bracket should face the back and stick upward in-between the third link center mast plates. Next attach the SMV sign to the bracket with the machine screws provided in the kit. The SMV should be visible from the rear and be oriented as shown below when finished.

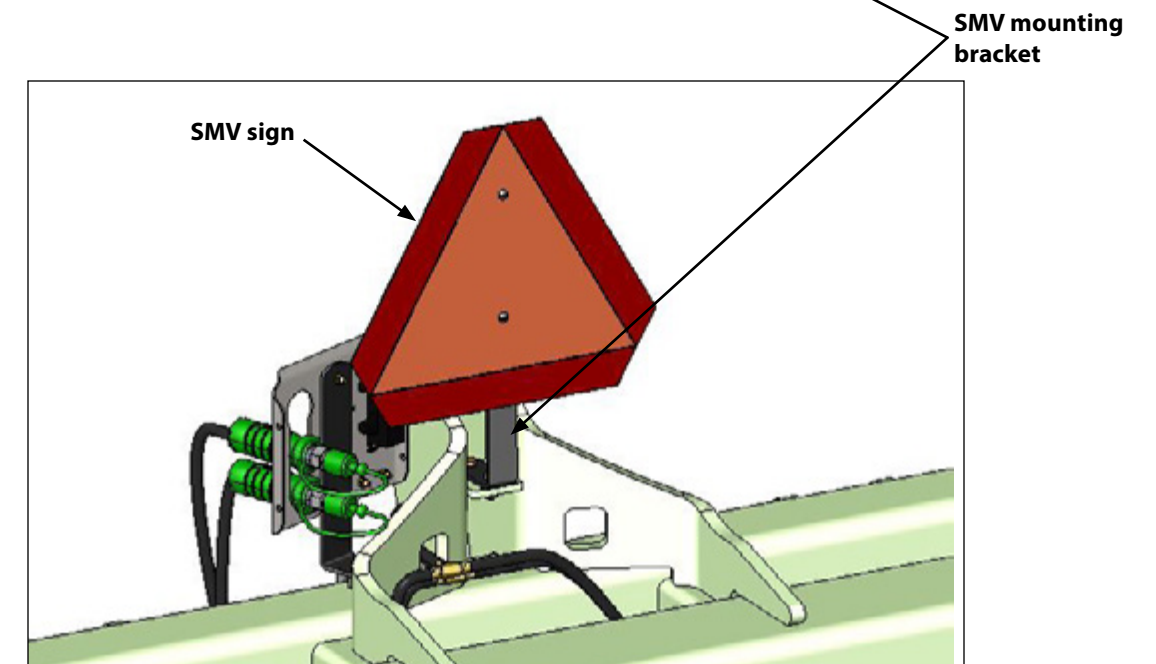
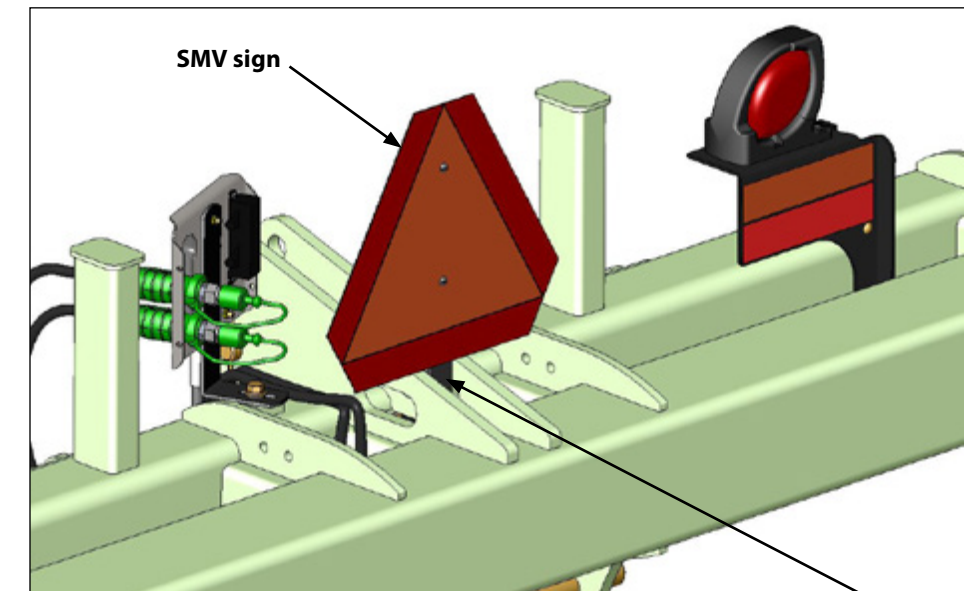

FIELD OPERATION



AVOID CRUSHING. Do not stand between tractor and implement when connecting or disconnecting implement. Injury or death can result from being trapped between the tractor and implement.



AVOID CRUSHING. Make sure all personnel are clear of the implement. Lower implement to the ground, place tractor in park, turn off engine, and remove key.

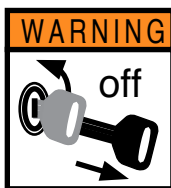

PLACE TRACTOR IN PARK AND REMOVE KEY BEFORE DISMOUNTING TRACTOR TO ADJUST IMPLEMENT.



NEVER ALLOW RIDERS ON TRACTOR OR IMPLEMENT. Riders hinder operator visibility and can be thrown from the implement and/or be struck by foreign objects resulting in injury or death.

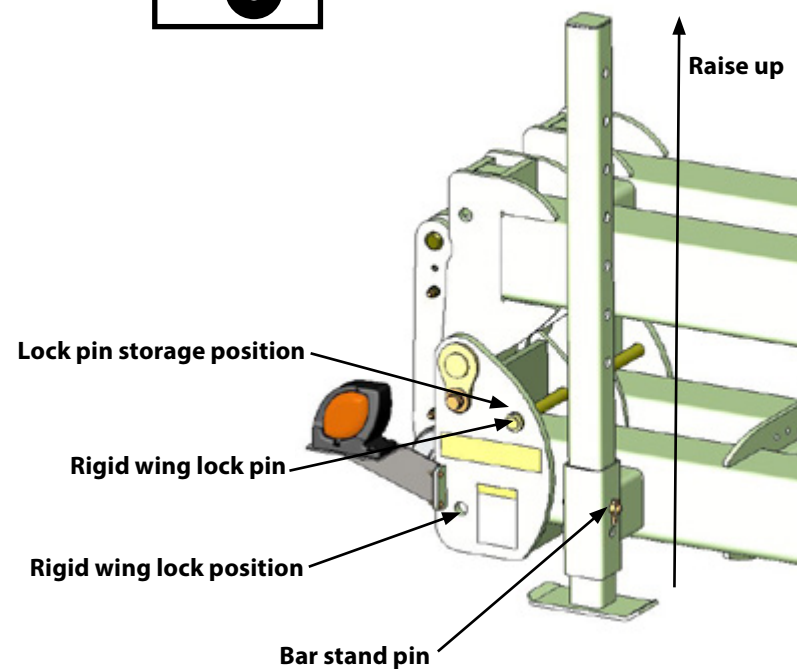

Make sure three point pins are not excessively worn.

Make sure implement/toolbar is attached securely to three point tractor hitch.

Make sure cab hydraulic control configuration is easily accessible and to the preference of the primary operator.

Make sure tractor is adequately ballasted for safe operation. Refer to owner's manual for proper ballasting instructions.

After tractor hook-up raise toolbar and remove Bar stand pin and raise bar stand to raised position, and replace bar stand pin.

Move Rigid wing lock pin from Rigid wing lock position to Lock pin storage position. The toolbar will not fold with the Rigid wing lock pins installed in the Rigid lock position.

FIELD OPERATION

RIGID OPERATION. For Rigid operation in the field: With wings completely unfolded, move Rigid wing lock pin from Lock pin storage position and install into Rigid wing lock position. This will keep wing from floating up. NOTE: Toolbar will not be able to fold with wings locked down.

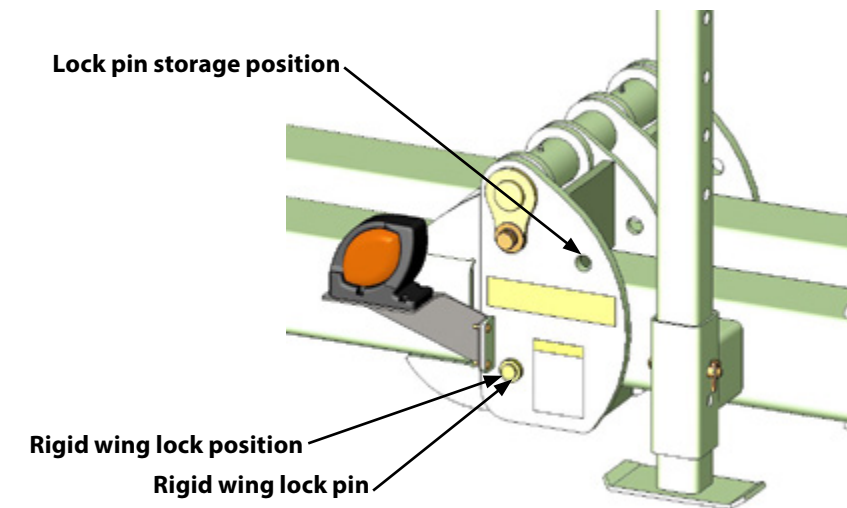

WING LEVELING. Factory setting for wing level bolts allows no downward wing position from level. If wings become out of adjustment, these bolts can be moved. Wing leveling bolts can also be adjusted so that wings will float down below factory setting. Smaller Row Crop Tillage toolbars will have 1 wing level bolt on each wing. Larger Row Crop Tillage toolbars will have 2 wing level bolts for each wing (shown below). If there are two wing level bolts per wing it is important that these bolts are adjusted so that both of them make contact with the wing so the load is distributed evenly.

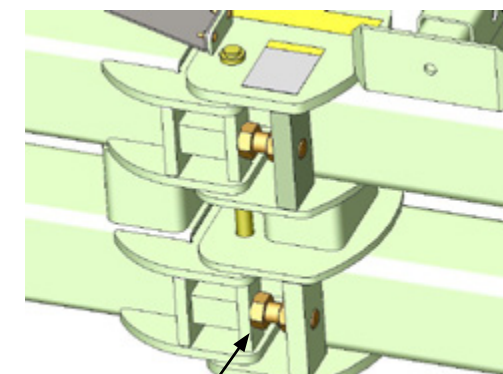

Wing leveling bolts making contact on wing plate

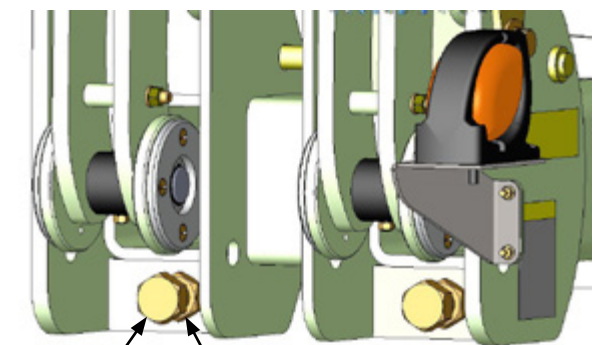

Wing leveling bolts Jam nuts

To adjust Wing leveling bolts: 1. Loosen Jam nut. 2. Adjust bolt or bolts. 3. Tighten Jam nut. Recommended Tools: 1 13/16 end wrench.

NOTE: Jam nuts are important for protecting the threads in the tapped plate and should not ever be removed from the assembly.

CAUTION

Be extremely careful working around unshielded sharp edges. Injury may result from contact with sharp edges.

153 - 045

PROBLEM:

Tractor will not hook up to three point hitch.

SOLUTION OPTIONS:

1. Tractor does not match three point hitch category on toolbar.

- Convert quick coupler on tractor to correct category. Refer to tractor operators manual.
- Switch quick coupler on tractor to correct category.



NOTE: Row crop tillage toolbars come from the factory with the proper hitch category options for the size of implement. For example: A category 3 hitch would be recommended for 12 row 30" cultivators. A category 4 hitch would be required for a 16 row 30" 1tRIPr.

NOTE: Refer to the images below to help determine the hitch category of your row crop tillage toolbar.

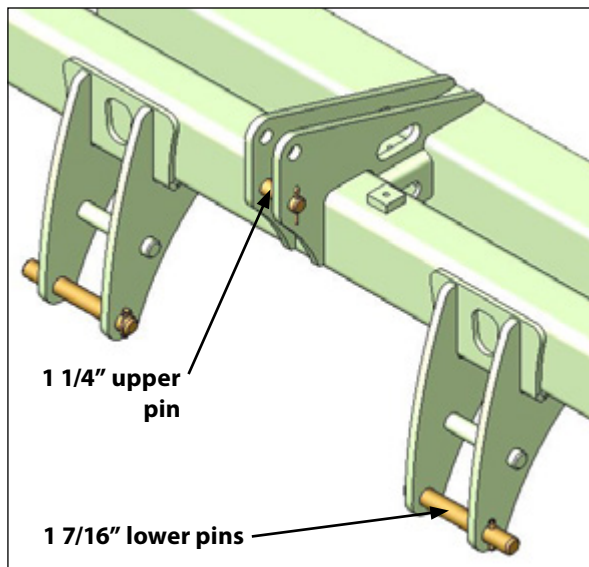

Category 3 - Fits Category 3 and 3N

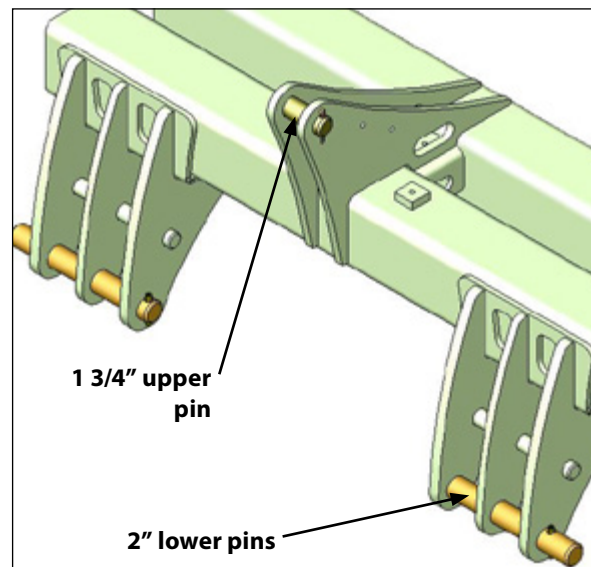

Category 4 - Fits Category 4 and 4N



AVOID CRUSHING. Make sure all personnel are clear of the implement. Lower implement to the ground, place tractor in park, turn off engine, and remove key.

USE BAR STANDS TO SUPPORT THE IMPLEMENT. Park implement on a clean, dry, and level surface. An uneven surface could cause implement to shift or fall, resulting in injury or death, as well as implement damage. Securely support all implement components that must be raised. Remove buildup of grease, oil, or debris prior to adjusting implement.

PROBLEM:

Wings do not fold or unfold.

SOLUTION OPTIONS:

1. Rigid wing lock pins installed.

- Remove wing lock pins. (see pg 4-1)

2. Hydraulic tips installed incorrectly in tractor SCV.

- Refer to tractor operator's manual or dealer for tractor hydraulic specifications.

3. Tractor hydraulic pressure is insufficient.

- Refer to tractor operator's manual or dealer for tractor hydraulic specifications.



NOTE: To avoid foreign objects in hydraulic oil, always clean hydraulic tips and outlets. Foreign material can ruin cylinders and plug restrictors.

CAUTION

Be extremely careful working around unshielded sharp edges. Injury may result from contact with sharp edges.

153 - 045

PROBLEM:

Wings do not fold or unfold. (cont.)

SOLUTION OPTIONS:

4. Hydraulic flow divider is faulty or plugged.

- (only toolbars with 4 fold cylinders have flow dividers)
- Refer to (pg. 7 - 8) for hydraulic manifold breakdown.
- Flow divider may need to be removed and cleaned or possibly replaced.

5. Hydraulic cylinder restrictors could be plugged.

- Refer to (pg. 5 - 4 & 5 - 5) for removal process of cylinder assembly.
 1. Remove hose from cylinder.
 2. Remove adaptor that goes in-between hose and cylinder port.
 3. Restrictor is located inside the adaptor and can be removed with allen wrench.
 4. Restrictor is made from a set screw with a .055 hole drilled in it.
 5. Check to see if hole is plugged.
 6. Clean and re-install.
- Refer to (pg. 7 - 5 & 7 - 6) for cylinder component identification and replacement parts.

6. Cylinder seal kit is bad.

- Refer to (pg. 5 - 4 & 5 - 5) for removal process of cylinder assembly.
- Refer to (pg. 7 - 7) for cylinder internal component identification and seal kit part number.

NOTE: To avoid foreign objects in hydraulic oil, always clean hydraulic tips and outlets. Foreign material can ruin cylinders and plug restrictors.



AVOID CRUSHING. Make sure all personnel are clear of the implement. Lower implement to the ground, place tractor in park, turn off engine, and remove key.

USE BAR STANDS TO SUPPORT THE IMPLEMENT. Park implement on a clean, dry, and level surface. An uneven surface could cause implement to shift or fall, resulting in injury or death, as well as implement damage. Securely support all implement components that must be raised. Remove buildup of grease, oil, or debris prior to adjusting implement.

REMOVAL OF INTERNAL CYLINDER

FOLD TOOLBAR:

1. Be sure rigid locking pin is in storage position (pg. 4 - 1)
2. Fold wings over until they hit wing stops so weight of wings are on stops.

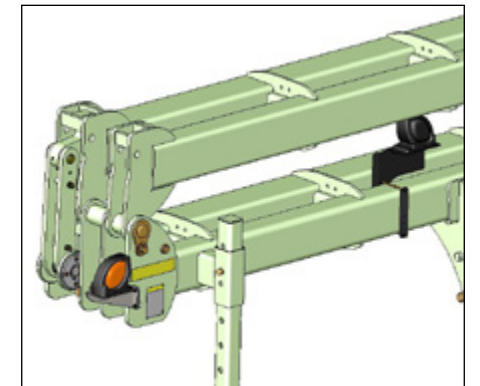

DISCONNECT HYDRAULIC HOSES:

1. Relieve hydraulic system pressure in tractor.
2. Unhook hydraulic hoses and store in courtsey palette.

3. For 1 cylinder wings: locate hydraulic tees near center of bar. Mark hoses and tees for easy re-assembly. Remove internal hoses from tee. (fig. A)
Cover open ends of hoses and tees to protect debris from entering hydraulic system.

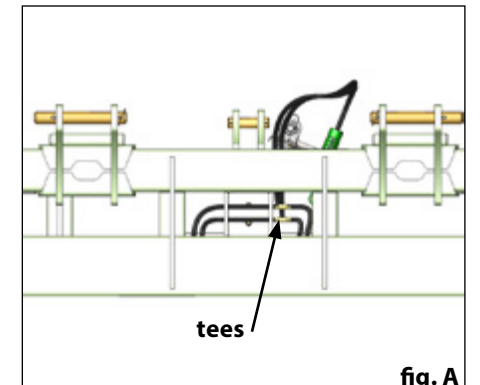

fig. A

For 2 cylinder wings: locate hydraulic manifold elbows. Mark hoses and elbows for easy re-assembly. Remove internal hoses from elbows. (fig. B)
Cover open ends of hoses and tees to protect debris from entering hydraulic system.

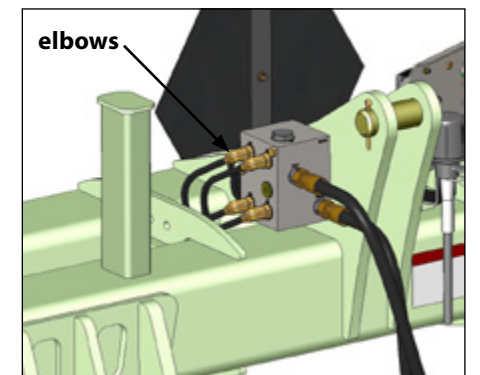

fig. B



Escaping pressurized hydraulic fluid can penetrate skin, resulting in injury or death. Relieve hydraulic system pressure before connecting or disconnecting tractor. Use cardboard or wood, **NOT BODY PARTS**, to check for suspected hydraulic leaks. Wear protective gloves and safety glasses or goggles when working with hydraulic systems. If an accident occurs, see a doctor immediately for proper treatment.

⚠ PRACTICE SAFE MAINTENANCE

Proper maintenance is your responsibility. Maintenance neglect and/or poor maintenance practices can result in injury or death. Always use the proper tools to maintain implement.

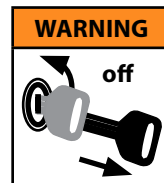

AVOID CRUSHING.

Make sure all personnel are clear of the implement. Lower implement to the ground, place tractor in park, turn off engine, and remove key.



USE BAR STANDS AND CYLINDER STOPS TO SUPPORT THE IMPLEMENT.

Park implement on a clean, dry, and level surface. An uneven surface could cause implement to shift or fall, resulting in injury or death, as well as implement damage. Securely support all implement components that must be raised. Remove buildup of grease, oil, or debris prior to maintaining implement.



AVOID ENTANGLEMENT. Never lubricate or service implement in motion. Keep away from power driven parts when in motion. Disengage power sources prior to maintaining implement. Injury or death can result from contact with power driven parts when in motion.



AVOID CRUSHING. Do not stand between the tractor and implement when connecting or disconnecting implement. Injury or death can result from being trapped between the tractor and implement.



Escaping pressurized hydraulic fluid can penetrate skin, resulting in injury or death. Relieve hydraulic system pressure before connecting or disconnecting tractor. Use cardboard or wood, NOT BODY PARTS, to check for suspected hydraulic leaks. Wear protective gloves and safety glasses or goggles when working with hydraulic systems. If an accident occurs, see a doctor immediately for proper treatment.

TORQUE SPECIFICATIONS

Unified Inch Bolt and Screw Torque Values

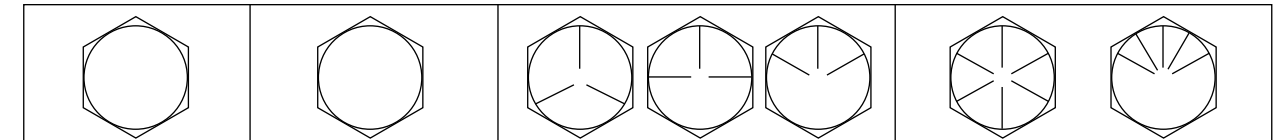

Bolt or Screw Size	SAE Grade 1		SAE Grade 2 ^a				SAE Grade 5, 5.1 or 5.2				SAE Grade 8 or 8.2					
	Lubricated ^b		Dry ^c		Lubricated ^b		Dry ^c		Lubricated ^b		Dry ^c		Lubricated ^b		Dry ^c	
	N·m	lb-in	N·m	lb-in	N·m	lb-in	N·m	lb-in	N·m	lb-in	N·m	lb-in	N·m	lb-in	N·m	lb-in
1/4	3.7	33	4.7	42	6	53	7.5	66	9.5	84	12	106	13.5	120	17	150
													N·m	lb-ft	N·m	lb-ft
5/16	7.7	68	9.8	86	12	106	15.5	137	19.5	172	25	221	28	20.5	35	26
									N·m	lb-ft	N·m	lb-ft				
3/8	13.5	120	17.5	155	22	194	27	240	35	26	44	32.5	49	36	63	46
			N·m	lb-ft	N·m	lb-ft	N·m	lb-ft								
7/16	22	194	28	20.5	35	26	44	32.5	56	41	70	52	80	59	100	74
	N·m	lb-ft														
1/2	34	25	42	31	53	39	67	49	85	63	110	80	120	88	155	115
9/16	48	35.5	60	45	76	56	95	70	125	92	155	115	175	130	220	165
5/8	67	49	85	63	105	77	135	100	170	125	215	160	240	175	308	225
3/4	120	88	150	110	190	140	240	175	300	220	380	280	425	315	540	400
7/8	190	140	240	175	190	140	240	175	490	360	615	455	690	510	870	640
1	285	210	360	265	285	210	360	265	730	540	920	680	1030	760	1300	960
1-1/8	400	300	510	375	400	300	510	375	910	670	1150	850	1450	1075	1850	1350
1-1/4	570	420	725	535	570	420	725	535	1280	945	1630	1200	2050	1500	2600	1920
1-3/8	750	550	950	700	750	550	950	700	1700	1250	2140	1580	2700	2000	3400	2500
1-1/2	990	730	1250	930	990	730	1250	930	2250	1650	2850	2100	3600	2650	4550	3350

Torque values listed are for general use only, based on the strength of the bolt or screw. DO NOT use these values if a different torque value or tightening procedure is given for a specific application. For plastic insert or crimped steel type lock nuts, for stainless steel fasteners, or for nuts on U-bolts, see the tightening instructions for the specific application. Shear bolts are designed to fail under predetermined loads. Always replace shear bolts with identical grade.

Replace fasteners with the same or higher grade. If higher grade fasteners are used, tighten these to the strength of the original. Make sure fastener threads are clean and that you properly start thread engagement. When possible, lubricate plain or zinc plated fasteners other than lock nuts, wheel bolts or wheel nuts, unless different instructions are given for the specific application.

^a Grade 2 applies for hex cap screws (not hex bolts) up to 6 in (152 mm) long. Grade 1 applies for hex cap screws over 6 in. (152 mm) long, and for all other types of bolts and screws of any length.

^b "Lubricated" means coated with a lubricant such as engine oil, fasteners with phosphate and oil coatings, or 7/8 in. and larger fasteners with JDM F13C zinc flake coating.

^c "Dry" means plain or zinc plated without any lubrication, or 1/4 to 3/4 in. fasteners with JDM F13B zinc flake coating.



LUBRICATION

- Grease - use high quality multi-purpose grease.
- Follow recommended 50 hour service interval illustrated below.

Single cylinder 180 degree fold toolbar

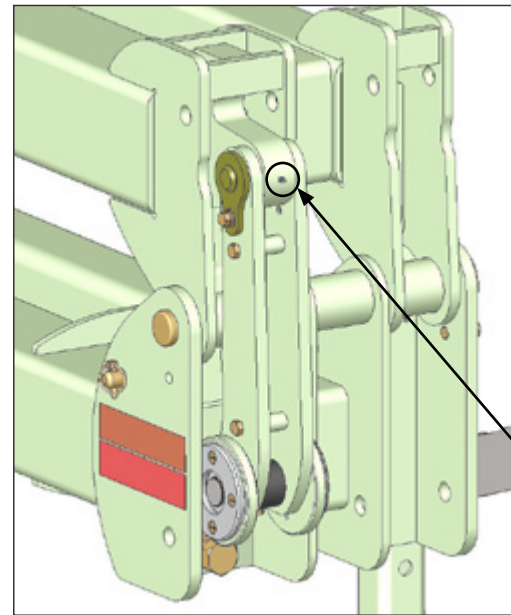

Dual cylinder 180 degree fold toolbar

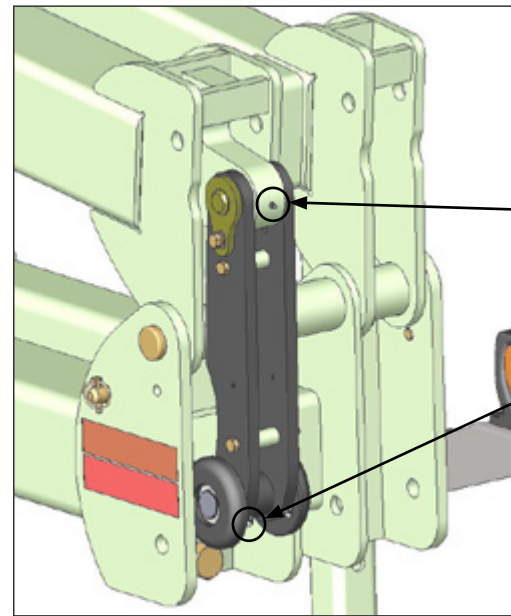
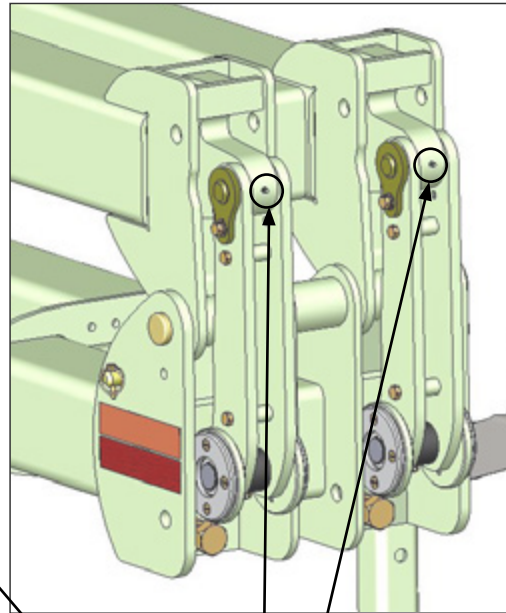

Single cylinder 170 degree fold toolbar

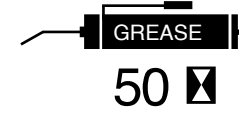
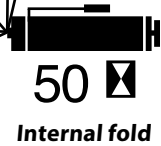

LUBRICATION

- Grease - use high quality multi-purpose grease.
- Follow recommended 50 hour service interval illustrated below.

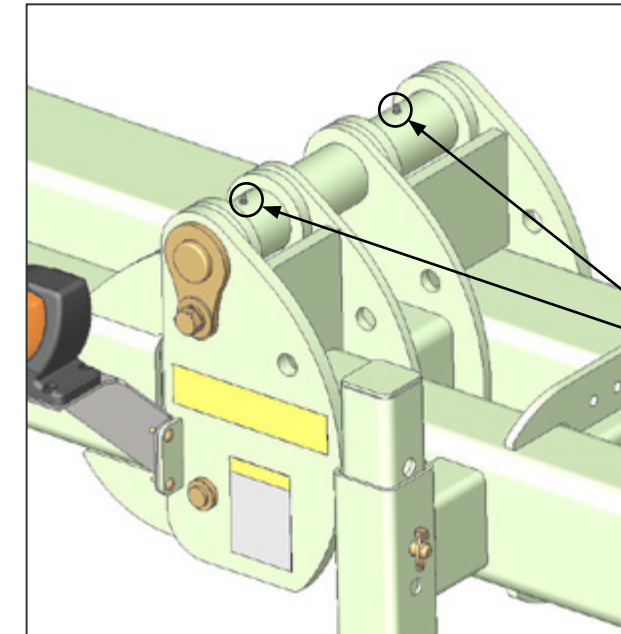

IMPLEMENT INSPECTION

- When replacement parts are necessary for periodic maintenance and servicing, genuine factory replacement parts must be used to restore implement to original specifications. Replace broken or worn parts immediately. Contact your Orthman dealer for replacement parts.
- During break-in (40 hours), check hardware for proper torque every 10 to 20 hours. (pg. 6 - 2)
- Before each use, check hardware for wear and proper torque. (pg. 6 - 2) Replace damaged or missing hardware with hardware of an identical grade to restore implement to original specifications.
- Do not allow debris to buildup on any surface of the implement.
- Replace all shields and guards. Be sure all tools, parts, and service equipment are removed prior to transporting equipment.



▲ IMPLEMENT STORAGE

- Clean and touch up paint seasonally to avoid corrosion and rust. Contact your Orthman dealer for touch up paint.
- Inspect all safety and Orthman decals and replace if missing or damaged. Contact your Orthman dealer for replacement decals. (pg. 2 - 10 thru 2 - 14)
- Grease all zerkers regardless of hourly interval prior to storage. (pg. 6 - 3, 6 - 4)
- Check all hardware according to torque specifications prior to storage. (pg. 6 - 2)
- Replace all worn or damaged parts prior to storage.
- Store inside if possible. Storing implement inside will prolong the life of the components.

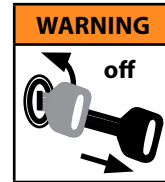

- ▲ AVOID CRUSHING.** Make sure all personnel are clear of the implement. Lower implement to the ground, place tractor in park, turn off engine, and remove key.

Storing implement on the ground will relieve the tractor three point hitch of hydraulic pressure. Hydraulic systems tend to settle, endangering anything underneath the implement.



USE BAR STANDS TO SUPPORT THE IMPLEMENT. Store implement on a clean, dry, and level surface. An uneven surface could cause implement to shift or fall, resulting in injury or death, as well as implement damage. Securely support all implement components that must be raised. Store implement away from human activity.

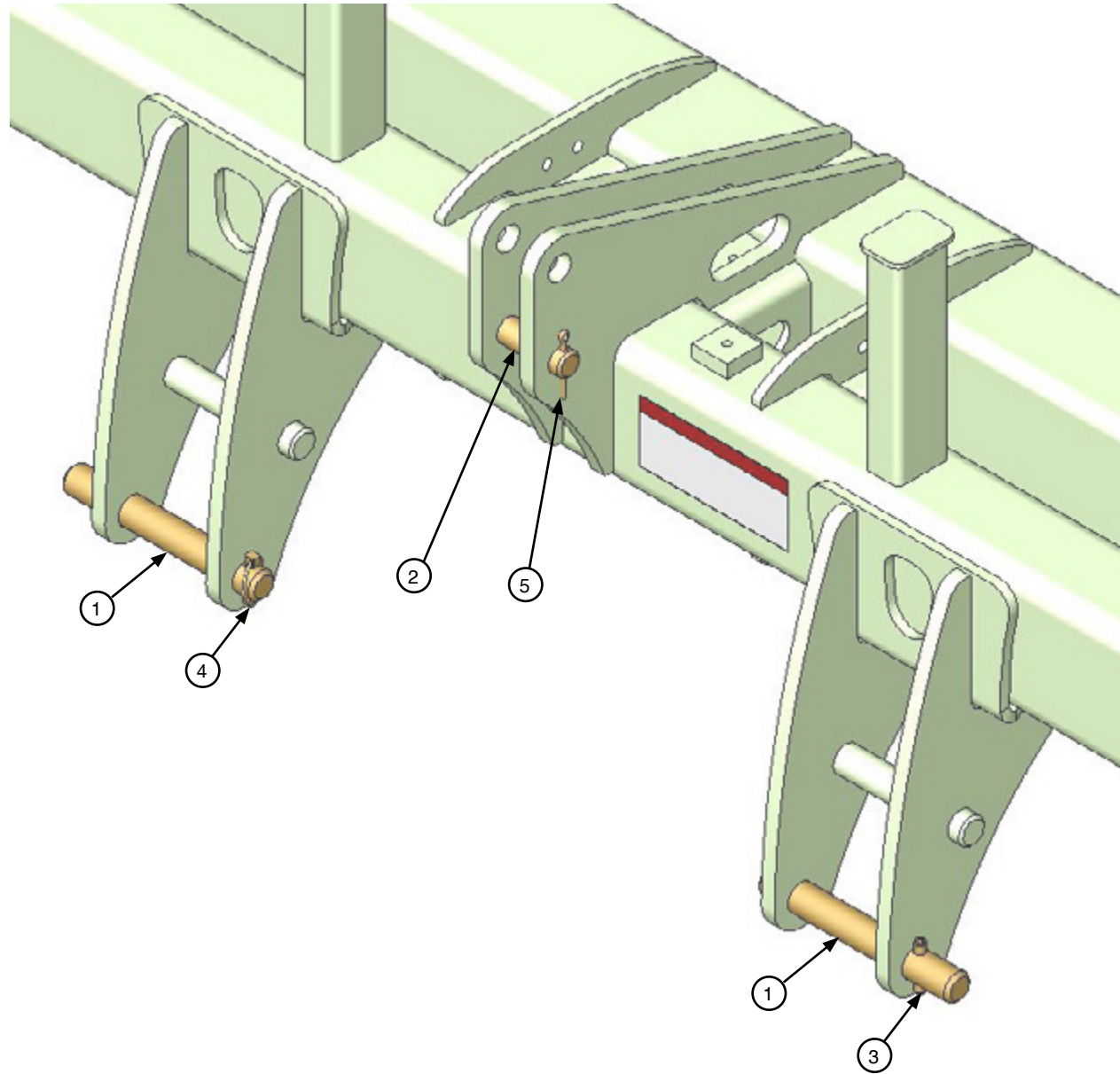

HITCH ASSEMBLY - CATEGORY 3

Key	Part #	Description	Qty	Notes
1	302-592	Lower hitch tug pin	2	1 7/16" x 10 7/8" long
2	302-591	Upper hitch pin	1	1 1/4" x 4 7/8" long
3	104-102	Roll pin	2	1/2" x 2 1/2"
4	104-036	Lynch pin	2	7/16" x 2" heavy duty
5	104-022	Cotter pin	2	1/2" x 2 1/2"

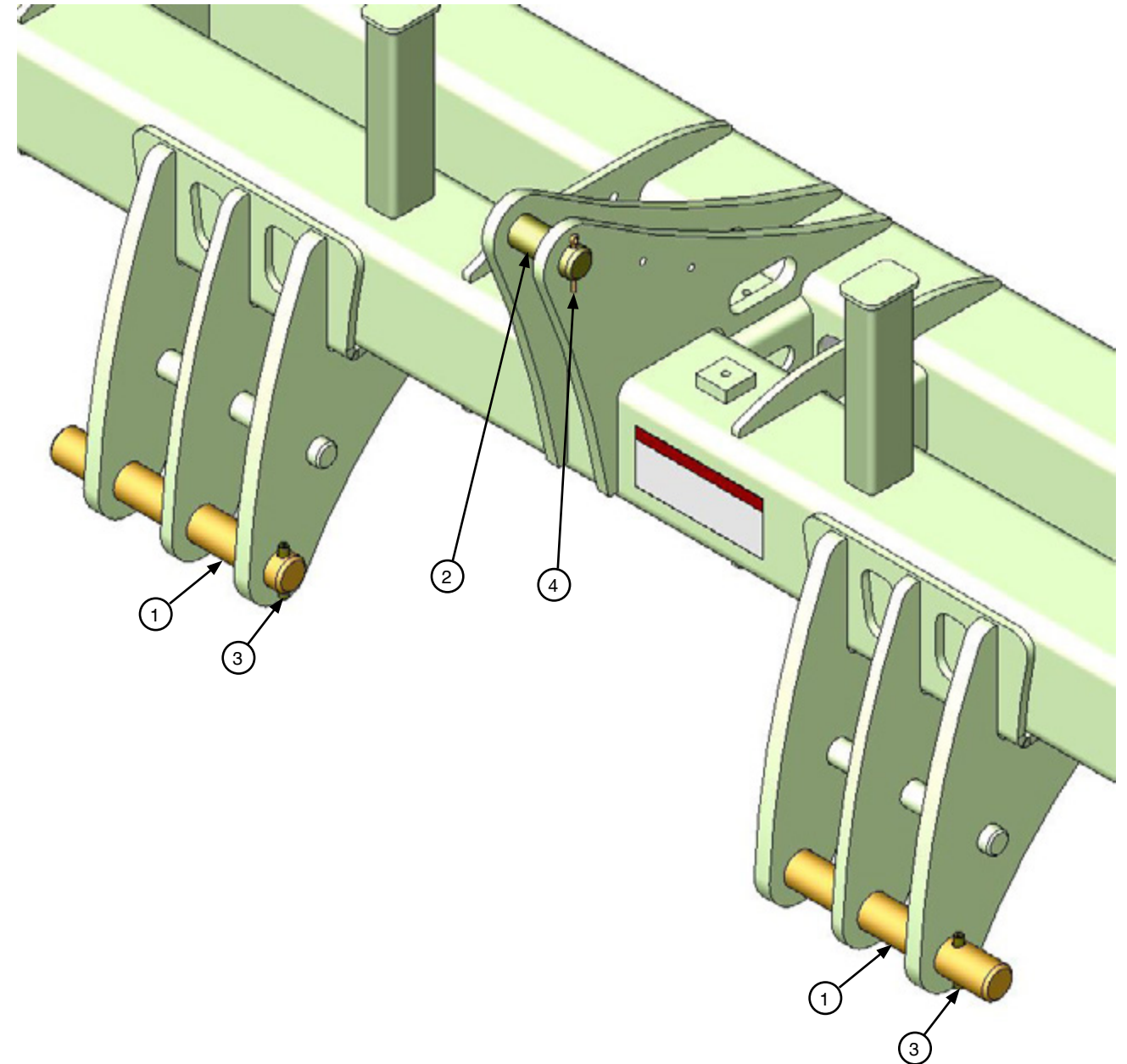

HITCH ASSEMBLY - CATEGORY 4

Key	Part #	Description	Qty	Notes
1	321-513	Lower hitch tug pin	2	2" x 15 3/8" long
2	321-512	Upper hitch pin	1	1 3/4" x 5 7/16" long
3	104-091	Roll pin	4	1/2" x 3" spiral
4	104-022	Cotter pin	2	1/2" x 2 1/2"

PARTS IDENTIFICATION

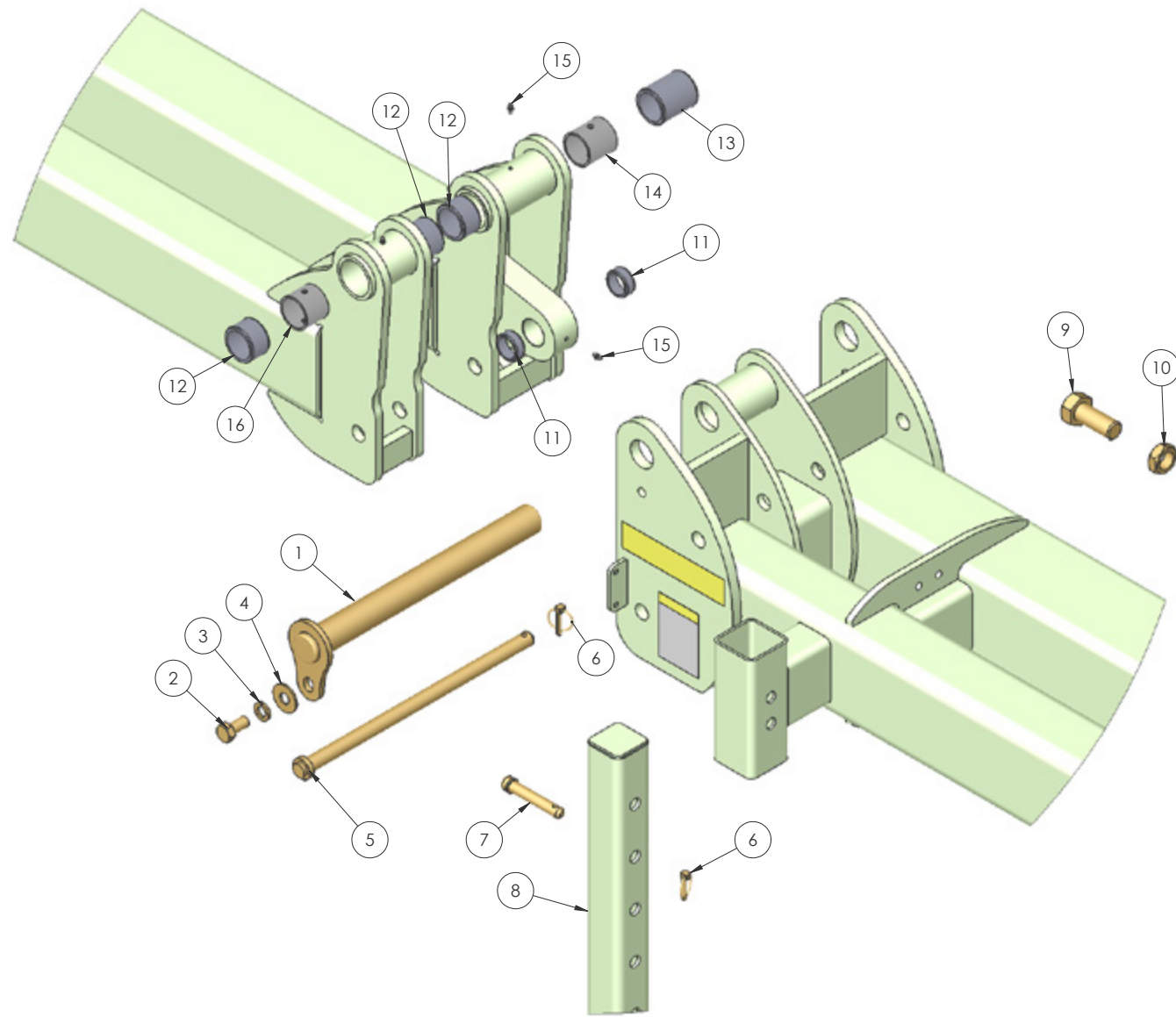

TOOLBAR HINGE ASSEMBLY 5X7 FRONT BAR

Key	Part #	Description	Qty	Notes	Key	Part #	Description	Qty	Notes
1	321-624	Hinge pin	2	2" x 20" long	9	100-471	Bolt	2	1 1/4" x 3", Grade 8
2	100-206	Bolt	2	3/4" x 1 1/2", Grade 5	10	102-077	Jam nut	2	1 1/4"
3	108-022	Lock washer	2	3/4"	11	134-040	Bushing, split	4	1 7/8" x 1 1/2" x 3/4" long
4	108-011	Flat washer	2	3/4"	12	134-097	Bushing, split	6	2 1/2" x 2" x 1 1/2" long
5	321-319	Lock pin	2	1" x 20 7/16" long	13	134-094	Bushing, split	2	2 1/2" x 2" x 3" long
6	104-065	Linch pin	4	5/16" x 1 11/16"	14	341-651	Spacer	2	2 3/8" long
7	303-846	Barstand pin	2	3/4" x 5" long	15	110-001	Grease fitting	4	1/4" straight
8	303-744	Bar stand	2	48"	16	341-652	spacer	2	1 7/8" long

PARTS IDENTIFICATION

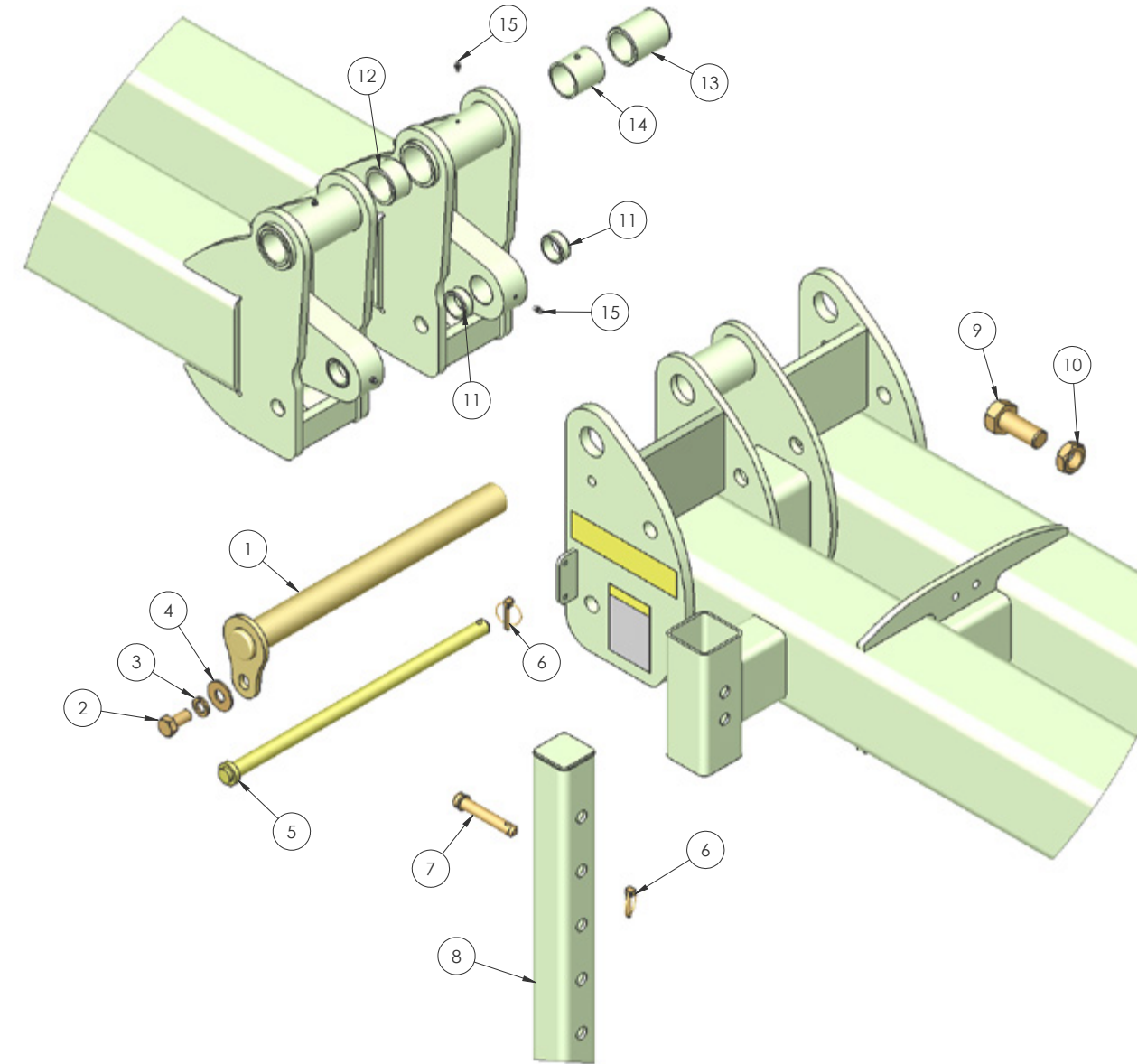

TOOLBAR HINGE ASSEMBLY 7X7 FRONT BAR

Key	Part #	Description	Qty	Notes	Key	Part #	Description	Qty	Notes
1	342-810	Hinge pin	2	2" x 22" long	9	100-471	Bolt	4	1 1/4" x 3", Grade 8
2	100-206	Bolt	2	3/4" x 1 1/2", Grade 5	10	102-077	Jam nut	4	1 1/4"
3	108-022	Lock washer	2	3/4"	11	134-040	Bushing, split	8	1 7/8" x 1 1/2" x 3/4" long
4	108-011	Flat washer	2	3/4"	12	134-097	Bushing, split	4	2 1/2" x 2" x 1 1/2" long
5	342-809	Lock pin	2	1" x 22 7/16" long	13	134-094	Bushing, split	4	2 1/2" x 2" x 3" long
6	104-065	Linch pin	4	5/16" x 1 11/16"	14	341-651	Spacer	4	2 3/8" long
7	303-846	Barstand pin	2	3/4" x 5" long	15	110-001	Grease fitting	8	1/4" straight
8	303-744	Bar stand	2	48"					

PARTS IDENTIFICATION

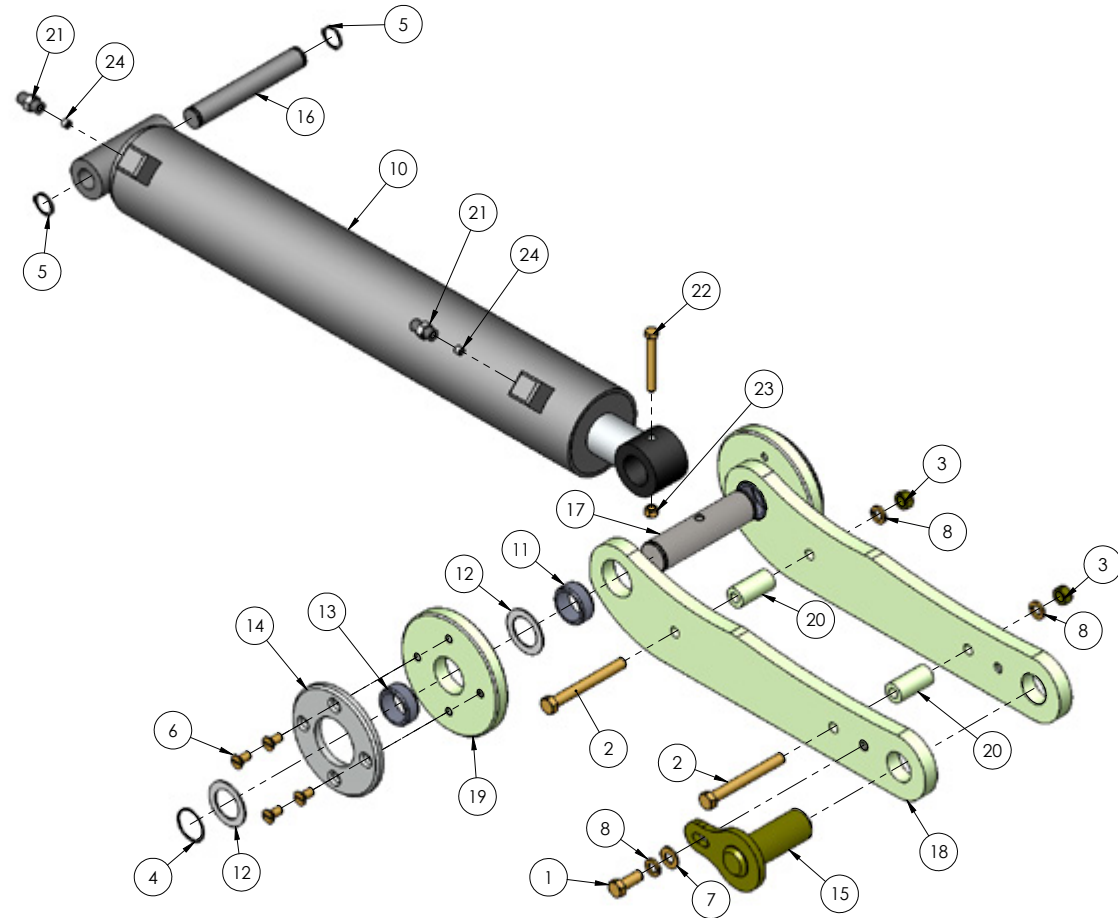

INTERNAL FOLD ASSEMBLY 180 DEGREE

Key	Part #	Description	Qty	Notes	Key	Part #	Description	Qty	Notes
1	100-115	Bolt	1	1/2" x 1 1/4", Grade 5	14	301-512	Friction plate	2	---
2	100-125	Bolt	2	1/2" x 4 1/4", Grade 5	15	301-548	Linkage pin	1	---
3	102-007	Nut	2	1/2"	16	301-500	Pin	1	6 7/8" long (for 3/8" wall bars)
4	104-052	Snap ring	2	1 1/2" external	16	301-800	Pin	1	6 9/16" long (for 1/2" wall bars)
5	104-053	Snap ring	2	1" external	17	301-948	Pin	1	5 7/8" long (for 3/8" wall bars)
6	106-107	Screw	4	3/8" x 3/4"	17	301-945	Pin	1	5 5/8" long (for 1/2" wall bars)
7	108-001	Flat washer	1	1/2"	18	341-823	Connecting strap	2	---
8	108-020	Lock washer	3	1/2"	19	301-511	Guide wheel	2	3/4" thick (for 3/8" wall bars)
9					19	301-802	Guide wheel	2	5/8" thick (for 1/2" wall bars)
10	194-499	Cylinder	1	4" x 24"	20	317-714	Spacer	2	---
11	134-040	Bushing, split	2	1 7/8" x 1 1/2" x 3/4"	21	340-078	Adaptor	2	9/16" MB x 9/16 MJ
12	134-041	Machined washer	4	2 1/4" x 1 1/2" x 14 ga.	22	100-098	Bolt	1	3/8" x 3", Grade 5
13	134-040	Bushing, split	2	1 7/8" x 1 1/2" x 3/4"	23	102-027	Lock nut	1	3/8"
	134-047	Bushing, split	2	1 3/4" x 1 1/2" x 5/8"	24	340-057	Restrictor	2	3/8" x 3/8" with .055 hole

PARTS IDENTIFICATION

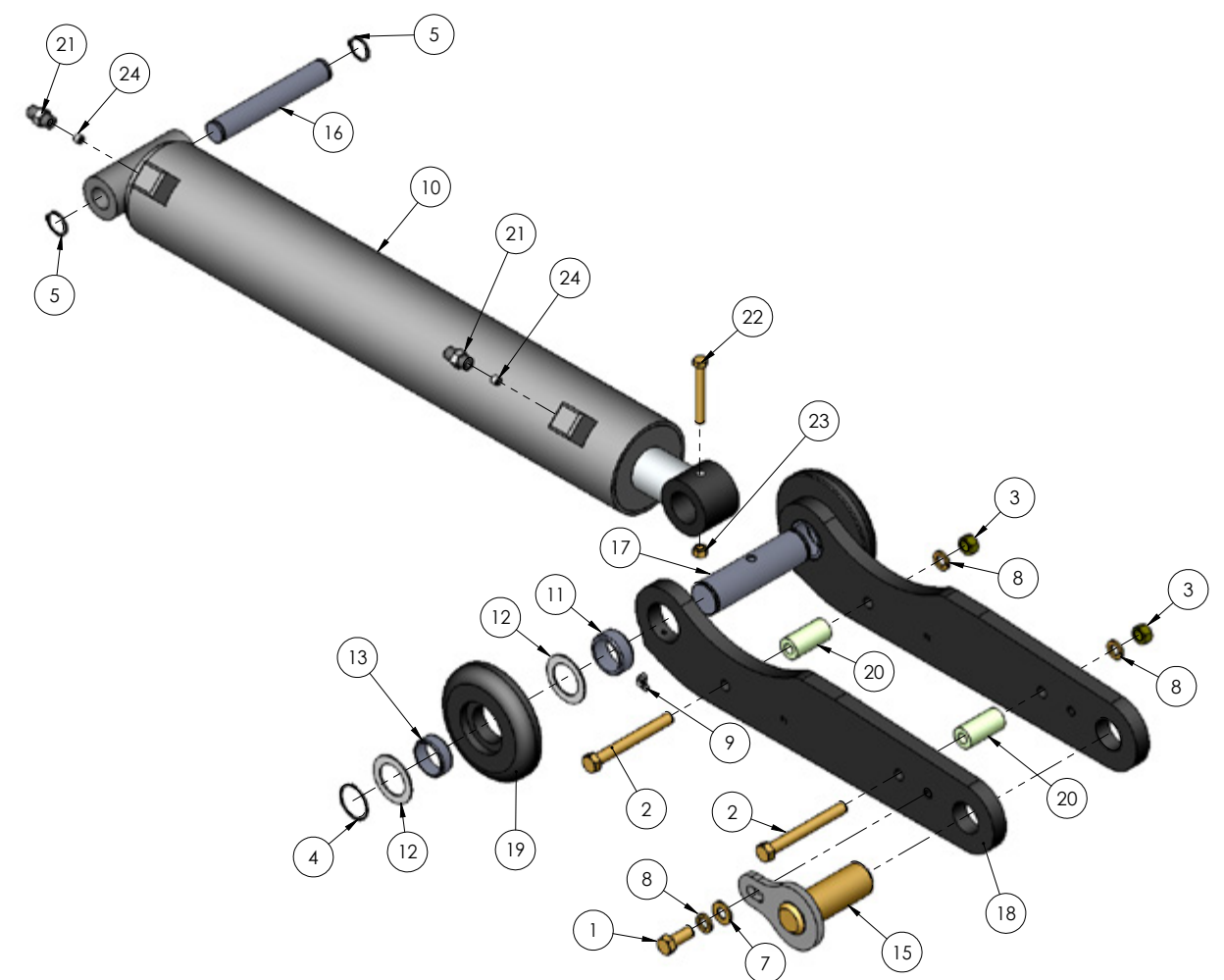

INTERNAL FOLD ASSEMBLY 170 DEGREE

Key	Part #	Description	Qty	Notes	Key	Part #	Description	Qty	Notes
1	100-115	Bolt	1	1/2" x 1 1/4", Grade 5	13	134-047	Bushing, split	2	1 3/4" x 1 1/2" x 5/8"
2	100-125	Bolt	2	1/2" x 4 1/4", Grade 5	14	301-512	Friction plate	2	---
3	102-007	Nut	2	1/2"	15	301-548	Linkage pin	1	---
4	104-052	Snap ring	2	1 1/2" external	16	301-800	Pin	1	6 9/16" long (for 1/2" wall bars)
5	104-053	Snap ring	2	1" external	17	301-945	Pin	1	5 5/8" long (for 1/2" wall bars)
6	106-107	Screw	4	3/8" x 3/4"	18	301-502	Connecting strap	2	black
7	108-001	Flat washer	1	1/2"	19	301-802	Guide wheel	2	1" thick (for 1/2" wall bars)
8	108-020	Lock washer	3	1/2"	20	317-714	Spacer	2	---
9	110-008	Grease fitting	2	1/4" x 90 degrees	21	340-078	Adaptor	2	9/16" MB x 9/16 MJ
10	194-499	Cylinder	1	4" x 24"	22	100-098	Bolt	1	3/8" x 3", Grade 5
11	134-040	Bushing, split	2	1 7/8" x 1 1/2" x 3/4"	23	102-027	Lock nut	1	3/8"
12	134-041	Machined washer	4	2 1/4" x 1 1/2" x 14 ga.	24	340-057	Restrictor	2	3/8" x 3/8" with .055 hole

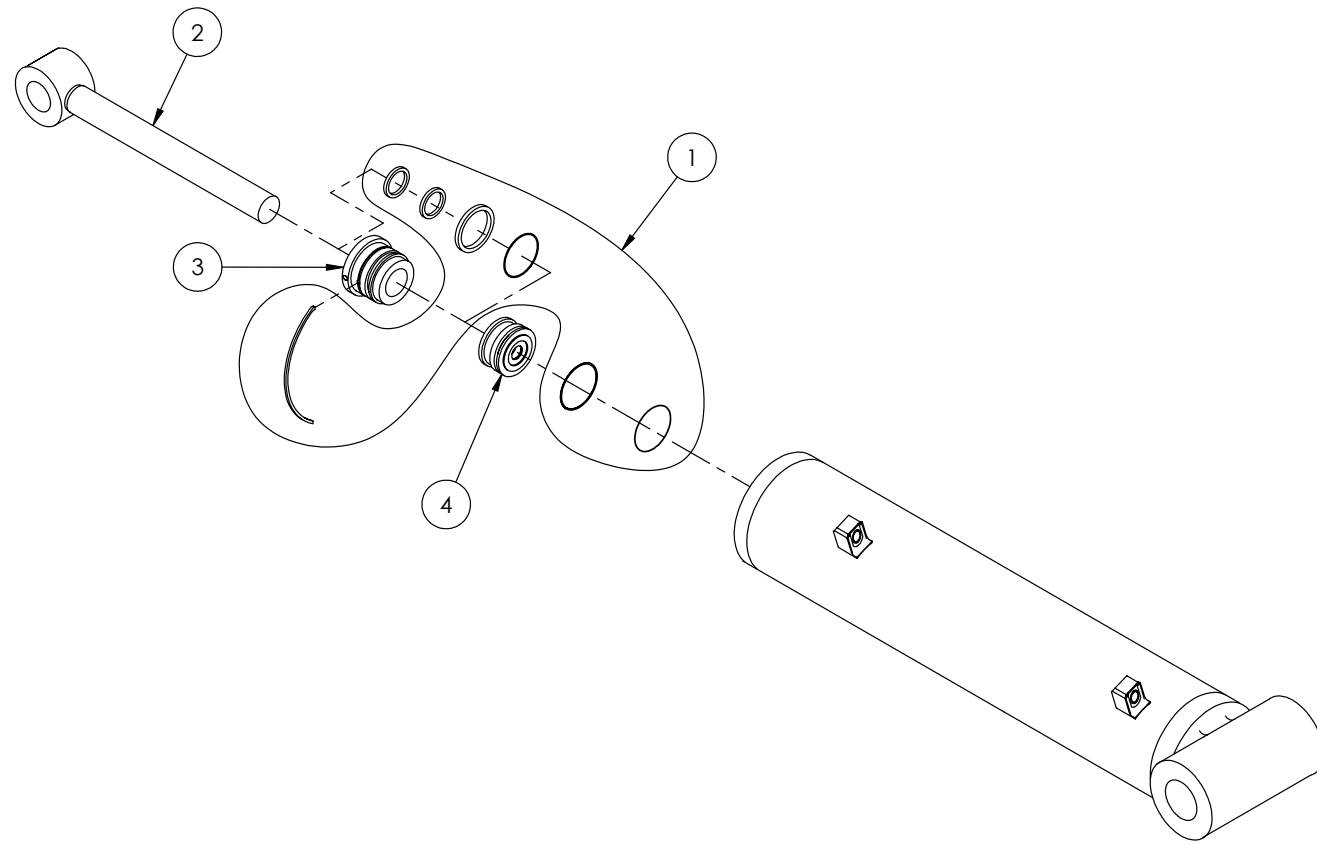

HYDRAULIC CYLINDER INTERNAL

Key	Part #	Description	Qty	Notes
1	194-440	Seal kit	1	for 194-499 cylinder
2	194-406	Cylinder rod	1	---
3	194-288	Gland	1	---
4	194-293	Piston	1	---

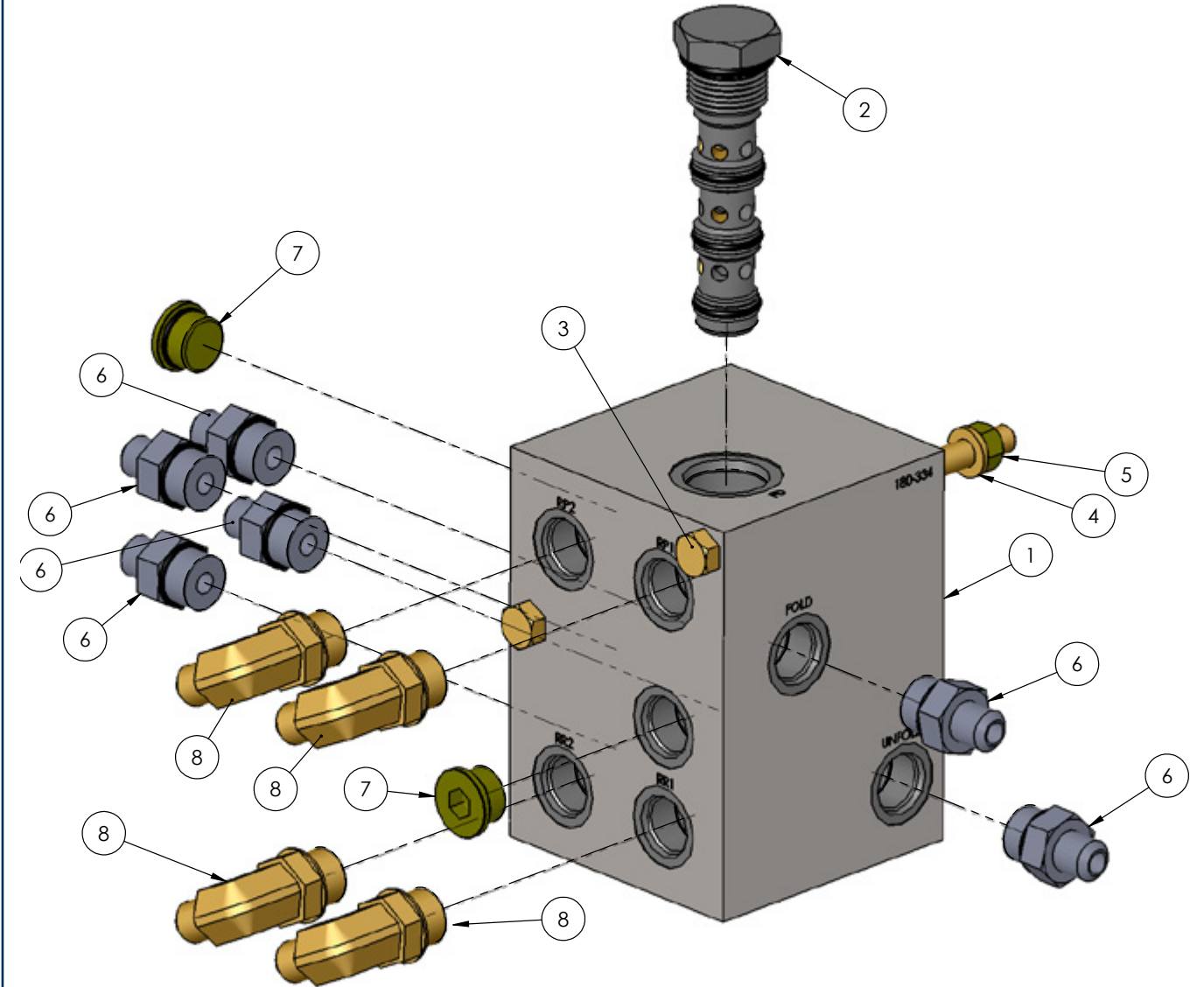

HYDRAULIC MANIFOLD ASSEMBLY

Key	Part #	Description	Qty	Notes
1	180-334	Manifold block	1	no fittings
2	180-279	Flow Divider	1	---
3	100-215	Bolt	2	3/8" x 5 1/2", Grade 5
4	108-018	Lock washer	2	3/8"
5	102-005	Nut	2	3/8"
6	198-078	Adaptor	6	3/4" MB - 9/16" MJ
7	198-210	Plug	2	3/4" MB
8	198-064	Elbow	4	3/4" MB - 9/16" MJ x 90 degrees
	341-623	Manifold Assembly		Includes item# 1 thru 8

PARTS IDENTIFICATION

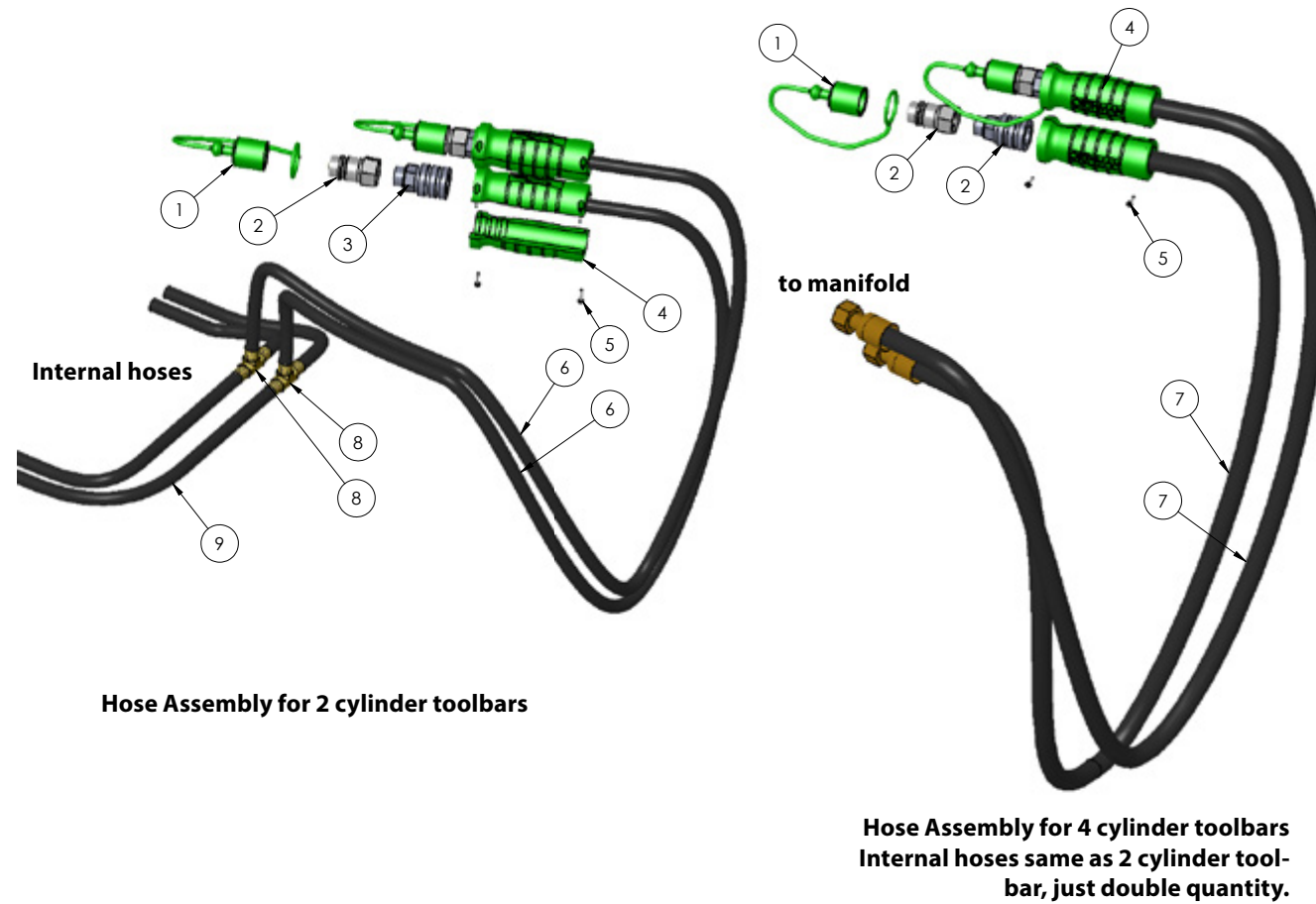

HYDRAULIC HOSE ASSEMBLY

Key	Part #	Description	Qty	Notes	Key	Part #	Description	Qty	Notes
1	152-712	Dustcap	2	green	9	302-897	Hyd hose - 36"		1/4" - 9/16 FJX x 9/16 FJX
2	140-092	Hydraulic tip	2	3/4" O-ring - Pioneer		301-464	Hyd hose - 48"		1/4" - 9/16 FJX x 9/16 FJX
3	198-313	Grip core	2	3/4" O-ring		196-111	Hyd hose - 60"		1/4" - 9/16 FJX x 9/16 FJX
4	198-224	Grip shell	2	Orthman logo - green		196-112	Hyd hose - 36"		1/4" - 9/16 FJX x 9/16 FJX
	198-225	Grip shell	1	Retract logo - green		196-140	Hyd hose - 36"		1/4" - 9/16 FJX x 9/16 FJX
	198-226	Grip shell	1	Extend logo - green		196-113	Hyd hose - 36"		1/4" - 9/16 FJX x 9/16 FJX
5	198-227	Screw	8	#6 x 1/2"		196-141	Hyd hose - 36"		1/4" - 9/16 FJX x 9/16 FJX
6	196-254	Hyd hose - 60"	2	3/8" x 9/16" FJX x 3/4" MORB		196-114	Hyd hose - 36"		1/4" - 9/16 FJX x 9/16 FJX
7	196-563	Hyd hose - 60"	2	1/2" x 9/16" FJX x 3/4" MORB		196-118	Hyd hose - 36"		1/4" - 9/16 FJX x 9/16 FJX
8	198-203	Tee	2	9/16" MJ x 9/16" MJ x 9/16" MJ		196-119	Hyd hose - 36"		1/4" - 9/16 FJX x 9/16 FJX
						196-454	Hyd hose - 36"		1/4" - 9/16 FJX x 9/16 FJX
						196-165	Hyd hose - 36"		1/4" - 9/16 FJX x 9/16 FJX

PARTS IDENTIFICATION

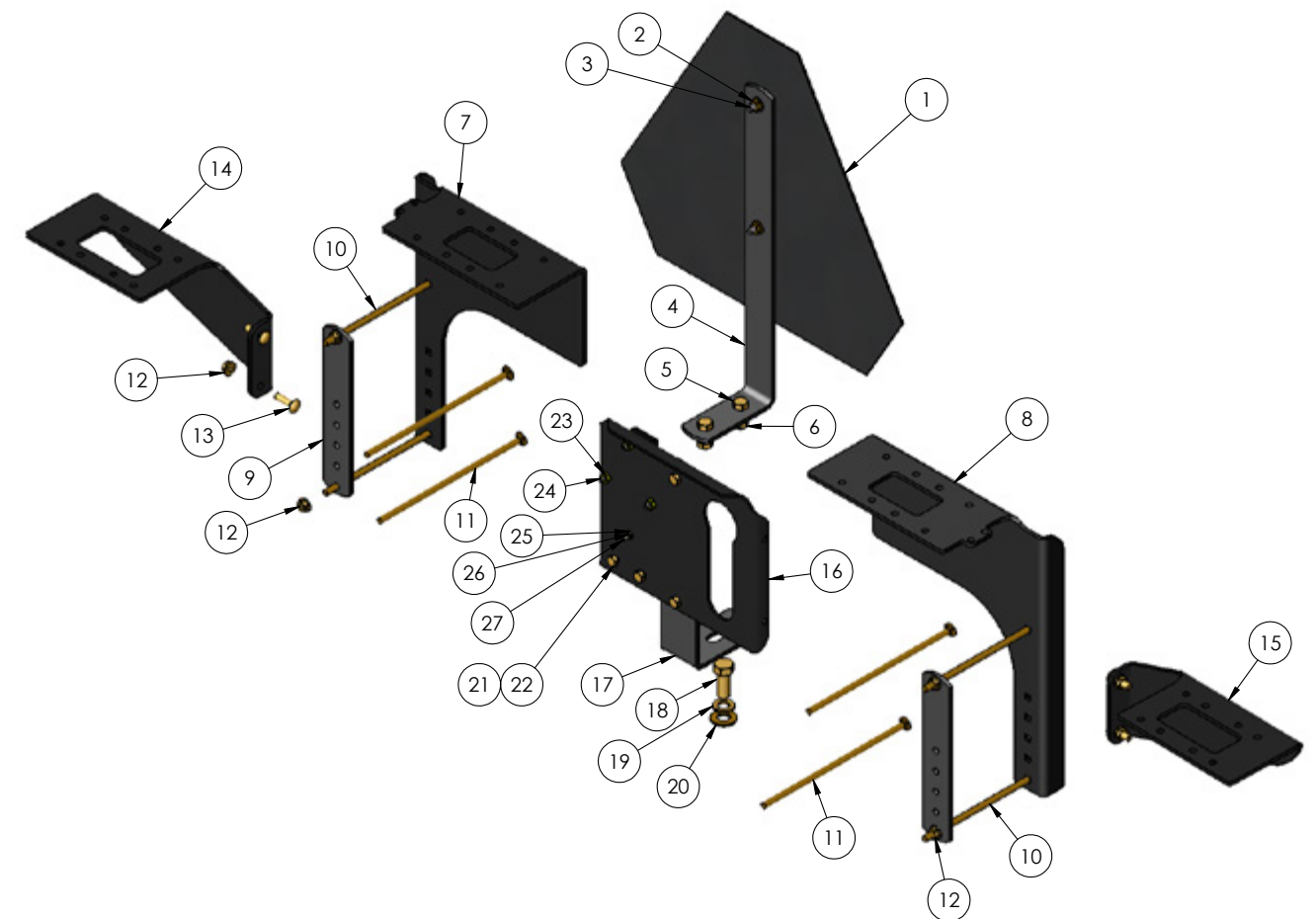

LIGHT MOUNTS, SMV AND COURTESY PALETTE

Key	Part #	Description	Qty	Notes	Key	Part #	Description	Qty	Notes
1	153-109	SMV sign	1	---	15	341-822	Light bracket	1	Outer Left
2	102-085	Flange nut	2	1/4"	16	341-826	Courtesy palette	1	plate
3	106-077	Screw	2	1/4" x 3/4", Rnd head	17	341-827	Mounting bracket	1	for courtesy palette
4	341-828	Mounting bracet	1	for SMV	18	100-115	Bolt	1	1/2" x 1 1/4", Grade 5
5	100-107	Bolt	2	3/8" x 1", Grade 5	19	108-020	Lock washer	1	1/2"
6	102-060	Flange nut	2	3/8", serrated	20	108-011	Flat washer	1	1/2"
7	341-824	Light bracket	1	Inner Right	21	100-253	Bolt	4	1/4" x 3/4", Grade 5
8	341-825	Light bracket	1	Inner Left	22	102-002	Nut	4	1/4"
9	333-499	Strap	2	mounting	23	102-034	Nut	3	#10
10	100-582	Carriage bolt	4	for 5x7 front bar	24	106-159	Screw	3	#10 x 5/8"
11	100-575	Carriage bolt	4	for 7x7 front bar	25	108-043	Lock washer	2	#8, internal tooth
12	102-227	Flange nut	8	1/4", serrated	26	102-082	Nut	2	#8
13	100-001	Carriage bolt	4	1/4" x 1", Grade 8	27	106-182	Screw	2	#8 x 1 1/2"
14	341-821	Light bracket	1	Outer Right					

PARTS IDENTIFICATION



LIGHT KIT ASSEMBLY - WESBAR

Key	Part #	Description	Qty	Notes	Key	Part #	Description	Qty	Notes
1	154-629	Harness - 84"	1	7 pin with logic module	7	152-055	cable ties	12	11 7/8"
2	154-630	Harness - 74"	1	Main wishbone cable	8	152-023	cable ties	8	28"
3	154-631	Cable - 13'	2	Amber light extension	n/a	154-682	Harness - 192"		7 pin with logic module
4	152-875	Light	2	Amber light	n/a	154-655	Extension cable - 13'		red light extension
5	152-874	Light	2	Red light	n/a	154-833	Extension cable - 10'		front harness extension
6	154-832	7 pin storage	1	protective boot		154-599	Wesbar ag light pack		Includes item# 1 thru 8

PARTS IDENTIFICATION

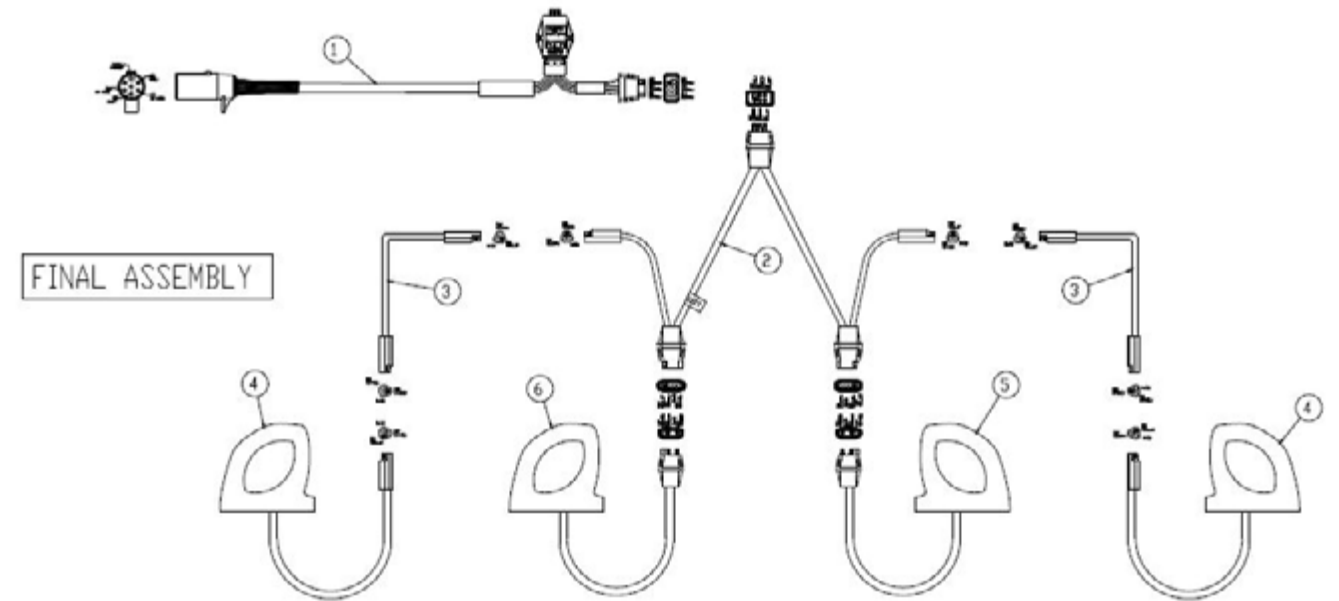

LIGHT KIT ASSEMBLY - COBO

Key	Part #	Description	Qty	Notes	Key	Part #	Description	Qty	Notes
1	154-829	Harness - 84"	1	7 pin with logic module	5	152-951	Light	2	Red light (right)
2	154-830	Harness - 74"	1	Main wishbone cable		152-705	lens	1	Red lens
3	154-831	Cable - 13'	2	Amber light extension		152-951	lens cover	1	blank black lens cover
4	152-950	Light	2	Amber light	6	152-952	Light	2	Red light (left)
	152-704	Lens	2	Amber lens only		154-832	7 pin storage	1	protective boot
	152-055	cable ties	12	11 7/8"		154-855	Extension cable		Red light extension
	152-023	cable ties	8	28"		154-831	logic module		replacement module



Orthman Manufacturing
Lexington, NE 68850 USA
orthman.com

