



Grain Handling

**GRAIN WAGON
MODEL 505**

Serial Number B32640100 & Higher

Part No. 301137

Foreword

 This symbol identifies important safety messages. When you see it, read the message that follows and be alert to the possibility of personal injury.

Remember, safety instructions stated in this manual are for your protection. Read them carefully and follow them closely when working around or using this machine.

Read and study this manual completely before attempting to operate this implement. Take this manual to the field for handy reference when operating, adjusting, or servicing your machine.

When referenced, “Right-Hand” (RH) and “Left-Hand” (LH) side of the machine are determined by standing behind the machine and facing in the direction of travel.



Product Information

When ordering parts or when requesting further information or assistance, always give the following information:

- Machine name
- Model number
- Serial number

All products manufactured by Unverferth Mfg. Co., Inc. are warranted to be free from material and workmanship defects for one full year from time of consumer delivery. Your local dealer will gladly assist you with any warranty questions.

Please fill out and retain this portion for your records.

Purchase Date _____ Model _____ Serial No. _____

Dealer _____ City _____

Dealer Contact _____ Phone _____

IMPORTANT

- *The information, specifications, and illustrations in the manual are based on information available at the time it was written. Due to continuing improvements in the design and manufacture of Unverferth products, all specifications and information contained herein are subject to change without notice.*

Table of Contents

**Section I
Safety**

General Hazard Information 1-2
 Safety Decals 1-3
 Following Safety Instructions 1-4
 Before Operating or Servicing 1-5
 During Operation 1-5
 Before Transporting 1-6
 During Transport 1-6
 Pressurized Oil 1-7
 Wearing Protective Equipment 1-8
 Prepare for Emergencies 1-8

**Section II
Set Up**

Set Up Checklist 2-2
 SMV Emblem & SIS Decals 2-3
 Important Check Points — Tires and Wheels 2-4
 Important Check Points — Tongue and Wheel Alignment 2-6
 Hitch 2-7
 Transport Chain 2-7
 Steering — Axle Stop Weldment 2-8
 Brake System — Sliding Hitch and Ladder 2-9
 Brake System — Master Cylinder 2-9
 Brake System — Brake Shoe Adjustment 2-10
 Brake System — Brake Bleeding 2-10
 Brake System — Manual Bleeding 2-10
 Electrical Hook-Up 2-11
 Wiring Harness with Brake Light Functionality 2-11
 Adjustable Chute 2-12
 Adjustable Transport Latch 2-12
 Hopper Reversal 2-13
 Fender Installation - Optional 2-14
 Rear Fenders 2-14
 Front Fenders 2-16
 Fenders for 425, 445, 455, 460 Tire Sizes 2-19
 Fenders for 560, 600 & Dual Tire Sizes 2-20
 Fender Light Installation - Optional 2-21
 Wiring (Where Applicable) 2-24
 Weather Guard Tarp Installation - Optional 2-25
 Hand Crank Handle 2-32

Table of Contents

**Section III
Operation**

Tandem Operation 3-2
 Chute 3-3
 Tarp Operation 3-4

**Section IV
Maintenance**

Seasonal Storage 4-2
 Electrical Schematic 4-3
 Wheels & Tires
 Wheel Nut Torque Requirements 4-4
 Tire Pressure 4-5
 Tire Warranty 4-5
 Complete Torque Chart
 Capscrews - Grade 5 4-6
 Brake Line Fittings - Torque and Installation 4-7
 13" Surge Brake Information
 Brake Shoe Adjustment 4-8
 Brake Shoe Centering 4-9
 Brake System Troubleshooting Guide 4-11
 Tarp Troubleshooting 4-12
 Inspection and Maintenance 4-12

**Section III
Parts**

Tongue 5-2
 Undercarriage Components 5-4
 Wheels and Tires 5-7
 Brake Components 5-8
 13" Brake Components
 Beginning with Serial #B33980100 5-10
 Prior to Serial #B33980100 5-12
 Gravity Box 5-14
 Fender Components 5-16
 Fender Light Components 5-18
 Door Wheel with Gear Reduction 5-20
 Kick Back Chute and SMV Components 5-22
 Chute and Latch Components 5-24
 Decals 5-26
 Touch-Up Paint 5-27
 Electrical Components 5-28
 Weather Guard Tarp Components - Optional 5-30

Notes

SECTION I

Safety

General Hazard Information	1-2
Safety Decals	1-3
Following Safety Instructions	1-4
Before Servicing	1-4
Before Operating	1-5
During Operation	1-5
Before Transporting	1-6
During Transport	1-6
Pressurized Oil	1-7
Prepare for Emergencies	1-8
Wearing Protective Equipment	1-8

General Hazard Information

No accident-prevention program can be successful without the wholehearted cooperation of the person who is directly responsible for the operation of the equipment.

A large number of accidents can be prevented only by the operator anticipating the result before the accident is caused and doing something about it. No power-driven equipment, whether it be transportation or processing, whether it be on the highway, in the field, or in the industrial plant, can be safer than the person who is at the controls. If accidents are to be prevented--and they can be prevented--it will be done by the operators who accept the full measure of their responsibility.

It is true that the designer, the manufacturer, and the safety engineer can help; and they will help, but their combined efforts can be wiped out by a single careless act of the operator.

It is said that, "the best kind of a safety device is a careful operator." We, at Unverferth Mfg. Co., Inc. ask that you be that kind of operator.



REMEMBER:
THINK SAFETY
A CAREFUL OPERATOR IS THE
BEST INSURANCE AGAINST AN
ACCIDENT!

SIGNAL WORDS



INDICATES AN EXTREMELY HAZARDOUS SITUATION OR ACTION THAT WILL RESULT IN SERIOUS INJURY OR DEATH.



INDICATES A HAZARDOUS SITUATION OR ACTION THAT COULD RESULT IN SERIOUS INJURY OR DEATH.



INDICATES AN UNSAFE SITUATION OR ACTION THAT MAY RESULT IN PERSONAL INJURY.



Is used for instruction on operating, adjusting, or servicing a machine.

Safety Decals

WARNING

- REPLACE LOST, DAMAGED, PAINTED, OR UNREADABLE DECALS IMMEDIATELY. IF PARTS THAT HAVE DECALS ARE REPLACED, ALSO MAKE SURE TO INSTALL NEW DECALS. THESE DECALS INFORM AND REMIND THE OPERATOR WITH OPERATIONAL INFORMATION AND SAFETY MESSAGES.

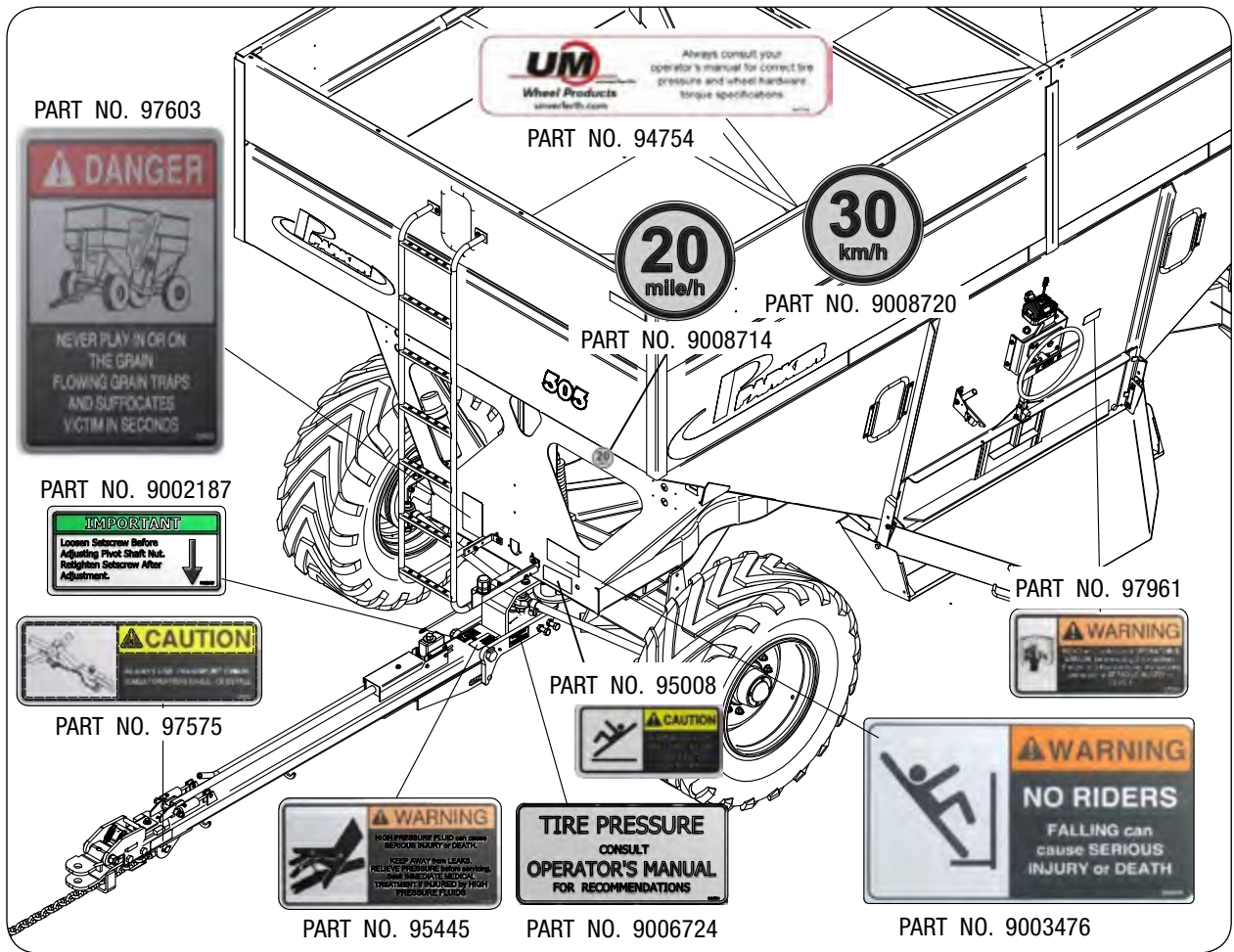

Following Safety Instructions

- Read and understand this operator's manual before operating.



- All machinery should be operated only by trained and authorized personnel.

- To prevent machine damage, use only attachments and service parts approved by the manufacturer.

- Always shut towing vehicle engine off and remove key before servicing the implement.



- Avoid personal attire such as loose fitting clothing, shoestrings, drawstrings, pants cuffs, long hair, etc., that may become entangled in moving parts.

- Do not allow anyone to ride on the implement. Make sure everyone is clear before operating machine or towing vehicle.



- Never attempt to operate implement unless you are in the driver's seat.



- Never enter a wagon containing grain. Flowing grain traps and suffocates victims in seconds.



Before Servicing

- Avoid working under an implement; however, if it becomes absolutely unavoidable, make sure the implement is safely blocked.



- Ensure that all applicable safety decals are installed and legible.

- To prevent personal injury or death, always ensure that there are people who remain outside the wagon to assist the person working inside, and that all safe workplace practices are followed. There is restricted mobility and limited exit paths when working inside the implement.

- Explosive separation of a tire and rim can cause serious injury or death. Only properly trained personnel should attempt to service a tire and wheel assembly.

Before Operating

- Do not stand between towing vehicle and implement during hitching.



- Always make certain everyone and everything is clear of the machine before beginning operation.

- Verify that all safety shields are in place and properly secured.



- Ensure that all applicable safety decals are installed and legible.

During Operation

- Regulate speed to field conditions. Maintain complete control at all times.

- Never lubricate equipment when in operation.

- Keep away from overhead power lines. Electrical shock can cause serious injury or death.



- Use extreme care when operating close to ditches, fences, or on hillsides.

- Do not leave towing vehicle unattended with engine running.

Before Transporting

- Secure transport chains to towing vehicle before transporting. **DO NOT** transport without chains.
- Check for proper function of all available transport lights. Make sure that all reflectors are clean and in place on machine. Make sure the SMV emblem is visible to approaching traffic.
- This implement may not be equipped with brakes. Ensure that the towing vehicle has adequate weight and braking capacity to tow this unit.

During Transport

- Comply with all laws governing highway safety when moving machinery.
- Use transport lights as required by all laws to adequately warn operators of other vehicles.
- Use good judgment when transporting equipment on highways. Regulate speed to road conditions and maintain complete control.
- Maximum transport speed of this implement should never exceed 20 mph as indicated on the machine. Maximum transport speed of any combination of implements must not exceed the lowest specified speed of the implements in combination. Do not exceed 10 mph during off-highway travel.
- Slow down before making sharp turns to avoid tipping. Drive slowly over rough ground and side slopes.
- It is probable that this implement is taller, wider and longer than the towing vehicle. Become aware of and avoid all obstacles and hazards in the travel path of the equipment, such as power lines, ditches, etc.

Pressurized Oil

- Relieve pressure before loosening any hydraulic fittings or servicing hydraulic system. See MAINTENANCE section of this manual for procedure to relieve pressure.

- High-pressure fluids can penetrate the skin and cause serious injury or death. Use cardboard or wood to detect leaks in the hydraulic system. Seek medical treatment immediately if injured by high-pressure fluids. 

- Hydraulic system must be purged of air before operating to prevent serious injury or death.

- Do not bend or strike high-pressure lines. Do not install bent or damaged tubes or hoses.

- Repair all oil leaks. Leaks can cause fires, personal injury, and environmental damage.

- Route hoses and lines carefully to prevent premature failure due to kinking and rubbing against other parts. Make sure that all clamps, guards and shields are installed correctly.

- Check hydraulic hoses and tubes carefully. Replace components as necessary if any of the following conditions are found:
 - End fittings damaged, displaced, or leaking.
 - Outer covering chafed or cut and wire reinforcing exposed.
 - Outer covering ballooning locally.
 - Evidence of kinking or crushing of the flexible part of a hose.
 - Armoring embedded in the outer cover.

Preparing for Emergencies

- Keep a first aid kit and properly rated fire extinguisher nearby.



- Keep emergency numbers for fire, rescue, and poison control personnel near the phone.



Wearing Protective Equipment

- Wear clothing and personal protective equipment appropriate for the job.



- Wear steel-toed shoes when operating.



- Wear hearing protection when exposed to loud noises.



- Do not wear additional hearing impairing devices such as radio headphones, etc.



SECTION II

Set Up

Pre-Delivery Checklist	2-2
SMV Emblem & SIS Decals	2-3
Important Check Points — Tires and Wheels	2-4
Important Check Points — Tongue and Wheel Alignment	2-6
Hitch.....	2-7
Transport Chain.....	2-7
Steering — Axle Stop Weldment	2-8
Brake System — Sliding Hitch and Ladder	2-9
Brake System — Master Cylinder	2-9
Brake System — Brake Bleeding	2-10
Brake System — Manual Bleeding.....	2-10
Electrical Hook-Up.....	2-11
Wiring Harness with Brake Light Functionality.....	2-11
Adjustable Chute	2-12
Adjustable Transport Latch.....	2-12
Hopper Reversal.....	2-13
Fender Installation - Optional.....	2-14
Rear Fenders	2-14
Front Fenders	2-16
Fenders for 425, 445, 455, 460 Tire Sizes.....	2-19
Fenders for 560, 600 & Dual Tire Sizes	2-20
Fender Light Installation - Optional.....	2-21
Wiring (Where Applicable)	2-24
Weather Guard Tarp Installation - Optional.....	2-25
Hand Crank Handle	2-32

Pre-Delivery Checklist

After the wagon has been completely assembled, use the following checklist and inspect the wagon. Check off each item as it is found satisfactory or after proper adjustment is made.

- Torque wheel nuts and check tire pressure as specified in Maintenance section.
- Tires are inflated to specified air pressure, located in the Maintenance section.
- Check to be sure all safety decals are correctly located and legible. Replace if damaged.
- Check to be sure all reflective decals are correctly located.
- Check to be sure SMV emblem and SIS decals are in place. See “SMV Emblem & SIS Decals” in SET UP section.
- Check to be sure transport lights are working properly.
- Transport chains are properly installed and hardware is torqued to specification. See “Transport Chain” in SET UP section.
- Paint all parts scratched in shipment.

SMV Emblem & SIS Decals

Before the wagon is used the reflective surface of the SMV must face rearward. This may require removal of film protecting the reflective surface or removing and reinstallation of the SMV. When reinstalling the SMV make sure that it is mounted with the wide part of the SMV at the bottom.



The SIS decals (one on the front and one on the rear of the wagon) may require removal of film protecting the decals.



Important Check Points

Tires and Wheels

1. Check tire pressures and maintain at recommended values listed in this manual.

For questions regarding new tire warranty, please contact your local original equipment tire dealer. Used tires carry NO WARRANTY. Tire manufacturers' phone numbers and web sites are listed in this manual for your convenience.

2. Check the torque of the wheel nuts/bolts.



CAUTION

- IMPROPERLY TORQUED WHEEL NUTS/BOLTS CAN CAUSE A LOSS OF IMPLEMENT CONTROL AND MACHINE DAMAGE. WHEEL NUTS/BOLTS MUST BE CHECKED REGULARLY. SEE TORQUE PAGE IN THE "MAINTENANCE" SECTION FOR PROPER WHEEL NUT/BOLT SPECIFICATIONS. WARRANTY DOES NOT COVER FAILURES CAUSED BY IMPROPERLY TORQUED WHEEL NUTS/BOLTS.

3. Check toe-in. Improper toe-in will cause excessive tire wear. Toe-in should be set at 1/16" per side. To adjust toe-in, set turning assembly perpendicular to the front axle. Then use a straight edge or sight the front tire straight with the rear tire. Once straight, turn 1/16" Tighten locknuts.

4. Grease all lube points daily during busy season:

- A. 1 on each front spindle pivot
- B. 3 on turning assembly pivot
- C. 1 on each tie rod end
- D. 2 on tongue on telescope latch plate.

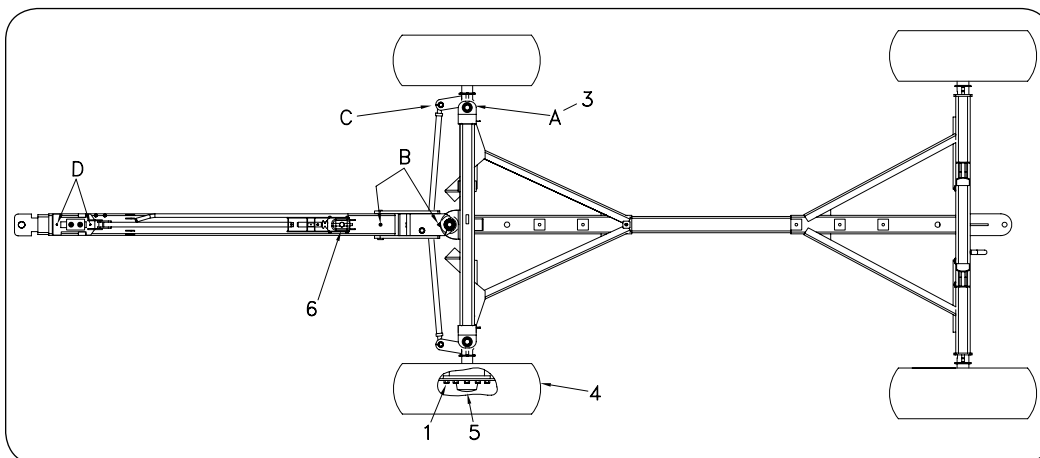
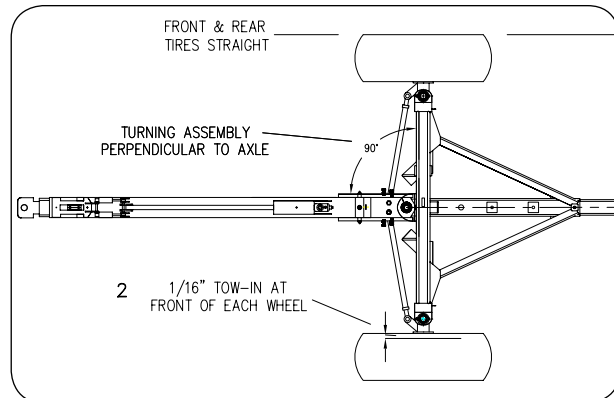

TIRES

For questions regarding new tire warranty, please contact your local original equipment tire dealer. Used tires carry no warranty. See "Tire Warranty" Section.

Important Check Points (continued)

5. Wheel hubs (check grease after first season of use.)

NOTE: The bearings are pressure packed with grease. An empty hub cavity does not indicate a lack of grease. It is not beneficial to fill the cavity.

6. Maintain brake fluid level in master cylinder. Lubricate push pipe and guides to ensure free movement. Adjust brake shoes as necessary. Rotate wheel for forward movement only. Tighten adjusting cog nut until you cannot rotate wheel by hand, then back off the adjustment until 3 - 4 threads are showing. And then additional threads may be necessary. See “Brake System” for detailed instructions.
7. When hauling corrosive materials such as fertilizers, it is advisable after use to wash out all excess materials to prevent premature rusting.

IMPORTANT

- *It is extremely important that the spindles are never welded to by the customer. Special manufacturing processes are utilized at the factory, and spindle weldments should always be replaced if repairs are necessary.*

Special manufacturing processes are utilized at the factory, and spindle weldments should always be replaced if repairs are necessary.

Important Check Points (continued)

Tongue and Wheel Alignment

Please refer to the following information for specific tongue/wheel alignment. If the tongue does not pull perpendicular to the front axle, the grain wagon can “dog-track”.

1. Use a straight edge or string to set front tires straight with rear tires.
2. Loosen right and left tie rod clamps.
3. Adjust distances “L” from the hitch pin to the right and left king pins equal on each side until tongue is perpendicular to front axle.
4. Again check that front and rear wheels are in a straight line. Set 1/16” Toe-In at front of each wheel. Tighten tie rod clamps.
5. Check tracking of wagon.

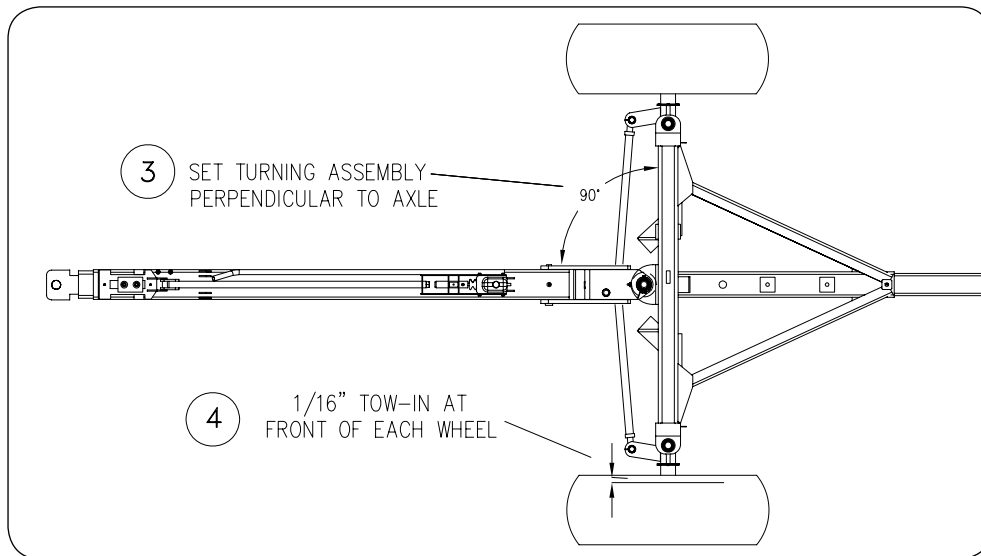
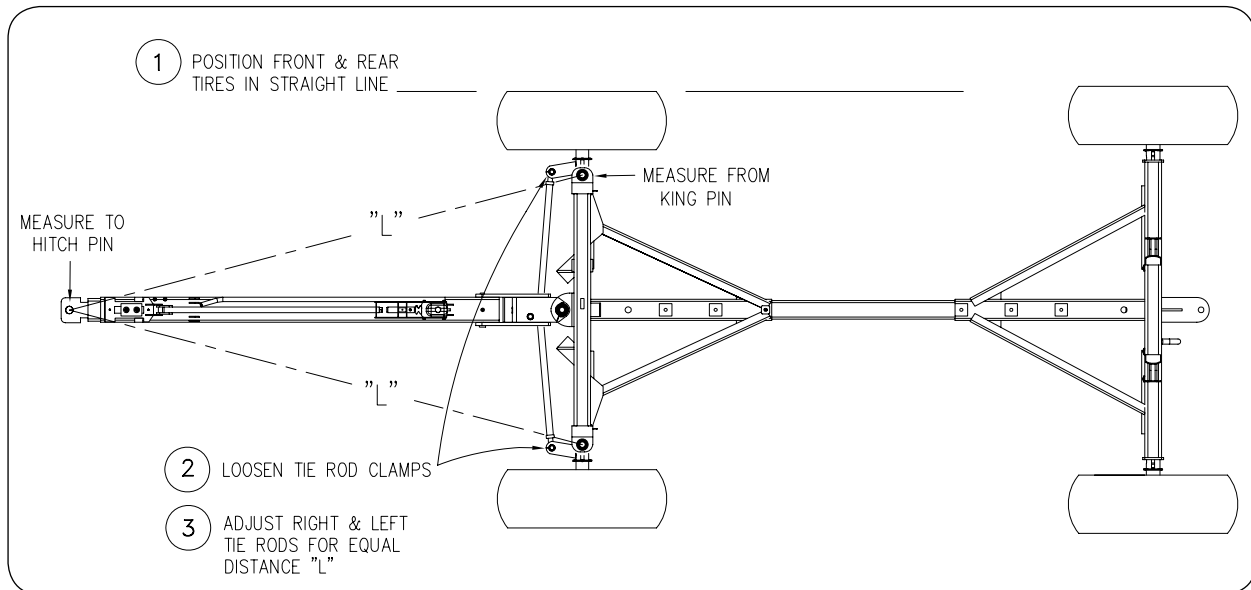

Hitch

The standard hitch pin size for your grain wagon is 1 1/4”.

IMPORTANT

- Failure to use the correct size hitch pin can cause premature failure of hitch clevis and tractor drawbar.

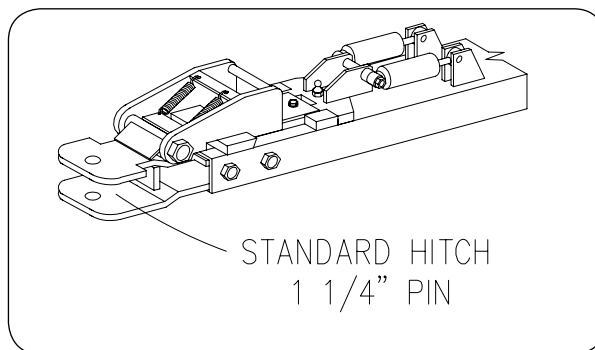

Transport Chain

CAUTION

- ALWAYS USE TRANSPORT CHAIN WHEN TRANSPORTING IMPLEMENTS. FAILURE TO USE CHAIN COULD CAUSE PERSONAL INJURY OR DAMAGE IF IMPLEMENTS BECOME DISENGAGED.
- REPLACE TRANSPORT CHAIN IF ANY LINK OR END FITTING IS BROKEN, STRETCHED, OR DAMAGED. DO NOT WELD TRANSPORT CHAIN.

Current model grain wagons feature a transport chain as standard equipment. This transport chain is sized for towing of one Model 505 grain wagon, fully loaded.

When multiple grain wagons are towed, the transport chain on the lead wagon must be sized accordingly.

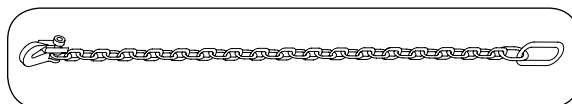

Transport Chain Part No.	Model	Max. Weight of Towed Unit(s) (lbs.)
95055	505	40,500
9003269	Option	60,500

Steering

Axle Stop Adjustment

Turn wheels both directions on level ground and adjust axle stop bolts for 1 - 1 1/2" clearance between inside tire edge and nearest frame.

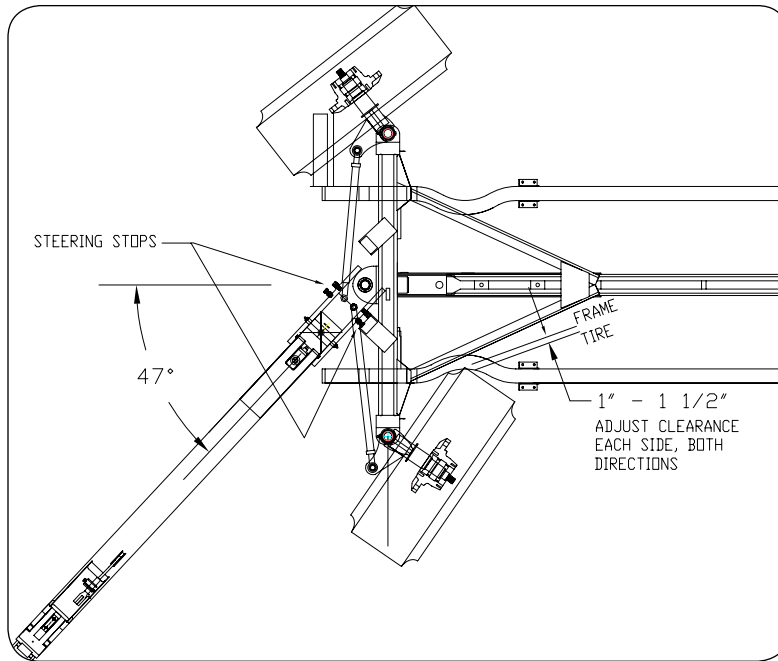

Brake System

⚠ WARNING

- HIGH-PRESSURE FLUIDS CAN PENETRATE THE SKIN AND CAUSE SERIOUS INJURY OR DEATH. USE CARDBOARD OR WOOD TO DETECT LEAKS IN THE HYDRAULIC SYSTEM. SEEK MEDICAL TREATMENT IMMEDIATELY IF INJURED BY HIGH-PRESSURE FLUIDS.
- HYDRAULIC SYSTEM MUST BE PURGED OF AIR BEFORE OPERATING TO PREVENT SERIOUS INJURY OR DEATH.

Sliding Hitch and Latch

The braking system on your running gear is designed to release automatically when you back up. Before adjusting individual brake shoes, inspect the master cylinder push plate for proper contact when the sliding hitch and latch mechanism is pulled forward.

NOTE: A maximum 1/4" gap is necessary to prevent possible "dragging" of brakes. Press lightly on plunger to eliminate play and set gap as close to 3/16" as possible for optimum performance.

Check the push tube for alignment and free movement in the tongue.

Master Cylinder

Brake fluid level may be checked by removing cap on master cylinder. Verify brake fluid level is to the neck of the cap. If not, refill level with a heavy-duty brake fluid that meets DOT-3. Do not clean any brake components in gasoline, kerosene, or oil.

NOTE: The cap o-ring should be lubricated with brake fluid prior to hand tightening. Hand tighten ONLY!

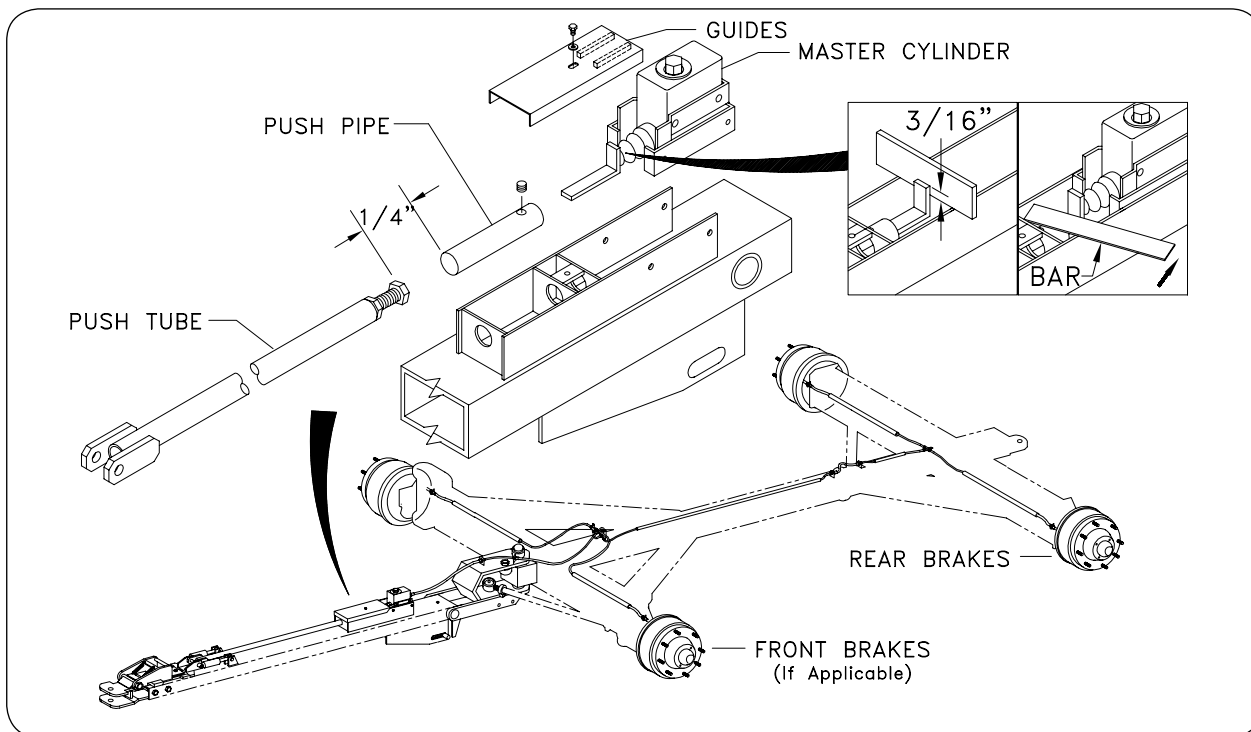

Brake System (continued)**Brake Bleeding**

Use **ONLY** quality DOT-3 heavy-duty brake fluid.

If pressure bleeding equipment is available, follow the manufacturer's instructions in bleeding the system.

Manual Bleeding

Fill master cylinder with fluid. Bleed rear brakes first (farthest from master cylinder). Loosen the bleeder screw located in wheel cylinder one turn. The system is now open to the atmosphere through a passage drilled in the screw. Securely install bleeder hose to bleed screw on first wheel cylinder to be bled.

Submerge the loose end of bleeder hose in a glass container filled approximately 1/3 full with brake fluid to observe expelled air bubbles while stroking master cylinder.

NOTE: The bleed hose must have a snug connection at bleed screw and remain submerged in brake fluid to avoid re-entry of air into the system.

Position a flat tool bar between master cylinder "L" bracket and housing (see illustration on the previous page) and pump master cylinder with long steady strokes. Continue to stroke master cylinder until bubbles stop rising to surface of fluid in glass jar. Remove hose and re-tighten bleeder screw.

Repeat bleeding operation at each wheel cylinder. During the bleeding process, replenish the brake fluid, so the level does not fall below the 1/2 full level in the master cylinder reservoir. After bleeding is completed, make sure master cylinder reservoir is filled and filler cap is securely in place.

NOTE: The cap o-ring should be lubricated with brake fluid prior to hand tightening. Hand tighten **ONLY!**

IMPORTANT

- *Saltwater, granular fertilizers and other corrosive materials are destructive to metal. To prolong the life of a braking system used under corrosive conditions, flush the actuator periodically with a high pressure water hose. Be sure to re-grease bearings and oil all moving parts after the unit has dried. At the end of the season, when unit is to be stored, remove the brake drums and clean inside the brakes. Pack wheel bearings before drum is installed. CAUTION: Do not pack hub full of grease. Excessive grease may leak into brake drums causing brake failure.*

Electrical Hook-Up

This Grain Wagon is supplied with a seven-point SAE connector plug which will connect with the receptacle found on most newer tractors. If your tractor does not have this type of receptacle, an SAE J-560 seven-point socket can be purchased from your Unverferth dealer (order Part #92824).

The wiring schematic for this wagon complies with ASABE Standards. Always verify correct electrical function before using this wagon.

Compliance with all lighting and marking laws is the responsibility of the operator at the time of travel.

See federal regulation 49 CFR 562; available at www.govinfo.gov for US federal law requirements.

See your Unverferth dealer for additional brackets, reflectors, or lights to meet your requirements.

Wires:

White = Ground

Green = Right Turn & Flasher Amber Light

Yellow = Left Turn & Flasher Amber Light

Brown = Tail Light

Black = Chute Light

Red = Brake Lights

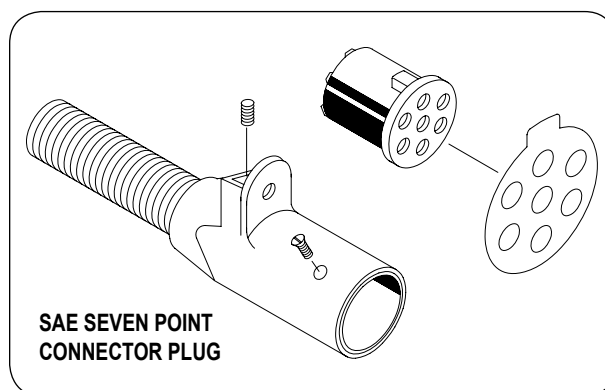

IMPORTANT

- Connect harness to tractor with sufficient slack and lock harness under small loop in spring. To retract harness, stow connector under large loop in spring.

NOTE: Wiring specifications may be different for older tractor models. Consult your tractor operator's manual or dealer for proper wiring and installation.

The electrical schematic can be found in the MAINTENANCE section of this manual.

Wiring Harness with Brake Light Functionality

This product may be equipped with brake light functionality which will activate the high intensity mode of the red tail lights when braking. The "RED" terminal of your tractor's electrical socket may or may not energize when the brakes are applied. Check your tractor's owner's manual. If your tractor does not energize the "RED" terminal when the brakes are applied, contact your dealer.

Adjustable Chute

Your grain wagon features an adjustable-height unloading chute. The adjustment bolt is located under the door area of the grain wagon. When the bolt is turned in (clockwise), the unloading height of the chute increases. When the bolt is turned out (counter-clockwise), the chute height is lowered.

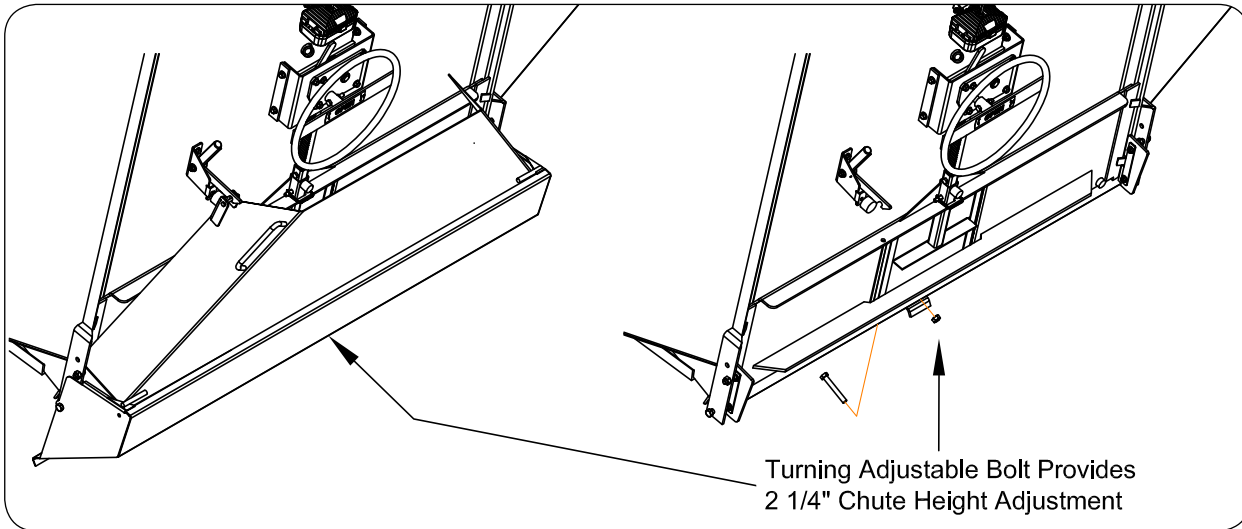

Adjustable Transport Latch

Adjust the rubber bumper so there is adequate pressure on the latch to properly retain chute during transport.

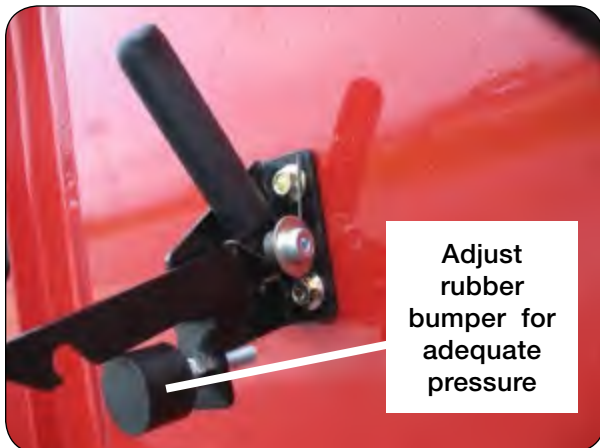

Hopper Reversal

WARNING

- **FALLING OBJECTS CAN CAUSE SERIOUS INJURY OR DEATH. DO NOT WORK UNDER THE MACHINE AT ANY TIME WHILE BEING HOISTED. BE SURE ALL LIFTING DEVICES AND SUPPORTS ARE RATED FOR THE LOADS BEING HOISTED. THESE ASSEMBLY INSTRUCTIONS WILL REQUIRE SAFE LIFTING DEVICES UP TO 4,000 LBS. SPECIFIC LOAD RATINGS FOR INDIVIDUAL LOADS WILL BE GIVEN AT THE APPROPRIATE TIME IN THE INSTRUCTIONS.**
 - **EYE PROTECTION AND OTHER APPROPRIATE PERSONAL PROTECTIVE EQUIPMENT MUST BE WORN WHILE SERVICING IMPLEMENT.**
 - **KEEP HANDS CLEAR OF PINCH POINT AREAS.**
1. Park the empty wagon on a firm, level surface. Block the tires on the machine to keep it from moving. Set the towing vehicle's parking brake, shut off the engine, remove the ignition key. 
 2. Using a safe lifting device rated for a minimum capacity of 4000 lbs. and lift height of 36 inches. Attach lifting harness to hopper so that the hopper will remain level while being lifted.
 3. Disconnect taillights and remove 7-pin connector from rear header. Remove main harness from rear panel and fold securely down on rear axle. Disconnect chute light harness from main harness and secure to undercarriage.
 4. If so equipped, remove all fenders, related mounting brackets and clearance light harness from undercarriage.
 5. Relieve spring tension on front axle hold down bracket by loosening and backing out hex capscrew approximately 2". Remove hold down pin at undercarriage attachment point and remove capscrews from elastic bumpers. Slide out bumper brackets when hopper weight is removed.
 6. Remove rear axle pins and slowly lift hopper off running gear. Raise hopper high enough for lower discharge chute to clear tire height and hold down bracket.
 7. If lifting device can rotate - slowly turn the hopper 180° and re-align over running gear. If lifting device cannot rotate - roll out running gear, reverse direction, and roll back under suspended hopper.
 8. Align undercarriage with rear axle brackets and front axle hold down bracket. Slowly lower hopper down on running gear.
 9. Reinstall rear axle pins to secure undercarriage to running gear.
 10. Re-install hold down bracket to undercarriage with pin. Slightly lift undercarriage 1/2" off front axle and install bumper brackets. Set undercarriage back down on axle, reassemble spring retainer and hex nuts to hold down spring shaft, and tighten nuts to end of threads for maximum spring tension.
 11. Remove tail lights, related wire harness, and mounting bracket with SMV sign from front and reinstall to rear. Route chute light harnesses from front to rear conduit, reconnect wire harness, and test all light functions. Secure harness to frame with tie wraps.
 12. Reinstall fender mounting brackets, fenders, and clearance light harness. Check tire-to-fender clearances and adjust as needed. Check clearance light operation.
 13. Remove ladder from rear and reinstall to front.
 14. Remove existing reflectors and install Reflector Kit #221451 - Locate (2) Amber to Front and (2) Red to Rear.

Fender Installation - Optional

WARNING

- EYE PROTECTION AND OTHER APPROPRIATE PERSONAL PROTECTIVE EQUIPMENT MUST BE WORN WHILE SERVICING IMPLEMENT.
- KEEP HANDS CLEAR OF PINCH POINT AREAS

NOTE: All capscrews and nuts which tighten directly against the plastic fenders must have a flat washer to provide adequate surface bearing.

Do not tighten fasteners during assembly. After all fenders are attached, visually align fenders with tires and tighten all fasteners.

Rear Fenders

1. Bolt rear top and bottom arms to frame with capscrews and flange nuts.



Fender Installation - Optional (continued)

Rear Fenders

2. Position rear fenders over top arms and secure with capscrews, fender washers and lock nuts.
3. Assemble mud flaps and bottom arms (RH & LH) to rear fenders as shown with capscrews, fender washers, and lock nuts. Make sure fender is straight and tighten hardware.

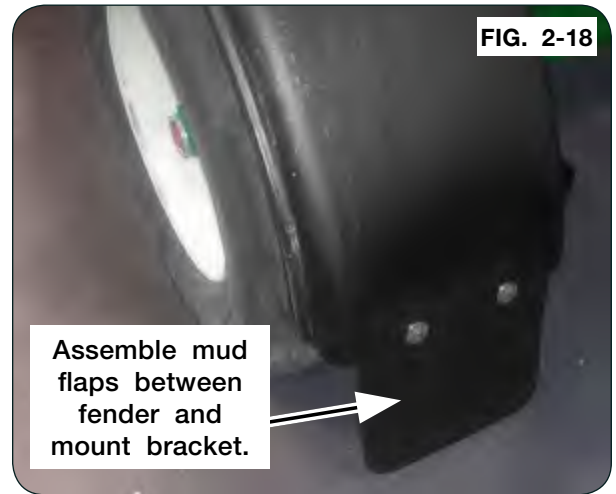

Fender Installation - Optional (continued)

Front Fenders

4. Bolt front top arms to frame with capscrews and flange nuts.
5. Use the fender mount plate (300672B) for mounting the front fender to the top arms on the standard tire fender kit.



Shown utilizing holes for 425, 455 Tires.



Shown utilizing holes for 445, 460 Tires.

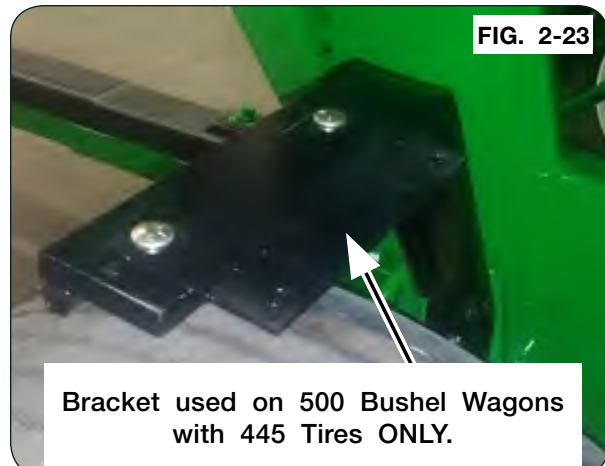

Bracket used on 500 Bushel Wagons with 445 Tires ONLY.

Fender Installation - Optional (continued)

Front Fenders

6. Mount tube to frame brackets with flange bolts and flange nuts. Refer to previous page for bolt and bracket locations.

FIG. 2-24



Assemble tube to rear of bracket as shown. Center from side to side.

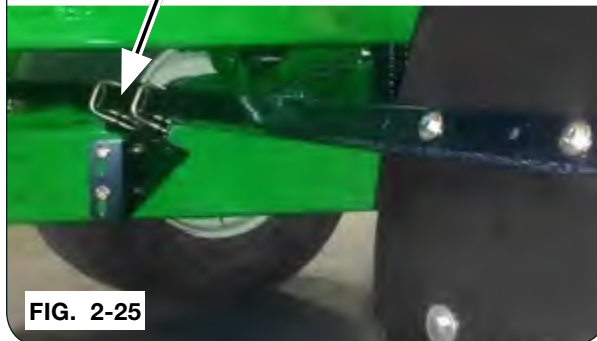

FIG. 2-25

7. Position front fenders over top arms and secure with capscrews, fender washers and lock nuts. Once fenders are completely assembled and clear tires, then tube and brackets must be tight and square with equally tightened threads on U-bolts.

FIG. 2-26



Fender Installation - Optional (continued)

8. Bolt front fenders to tube with $3/8 \times 2\ 1/2$ capscrews, fender washers and lock nuts in top holes.
9. Assemble mud flaps and back plates to front fenders with $3/8 \times 1$ capscrews, fender washers and lock nuts in bottom holes.



10. Visually align fenders from front or rear and tighten all fasteners. Align edge of 12" x 26" plastic laminate with rear edge of hopper (behind chute) and apply. Trim laminate as required for hopper profile.

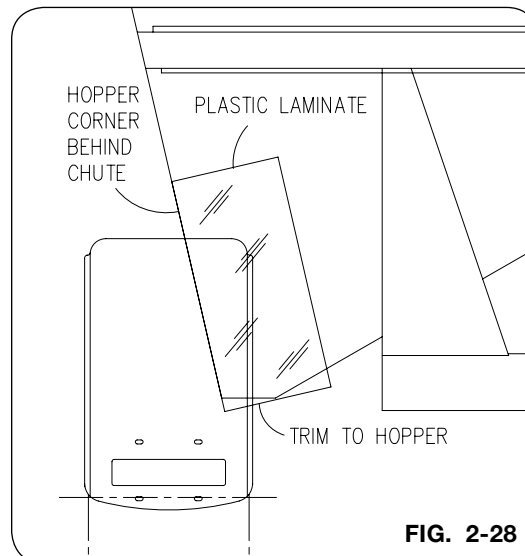

Fender Installation - Optional (continued)

Fenders for 425, 445, 455, 460 Tires Sizes

Use these hole locations when using Tire Sizes.

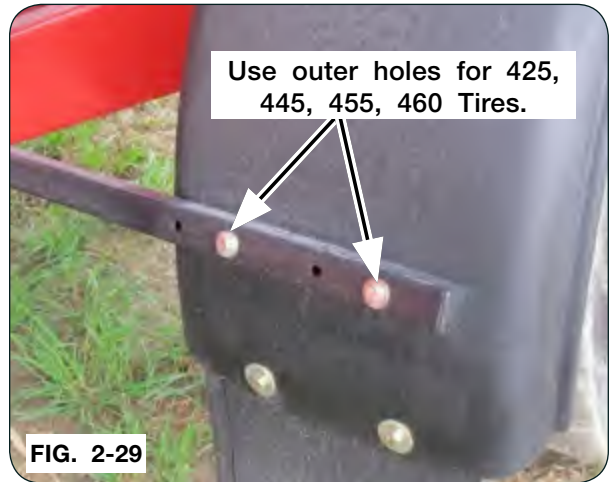

Fender Installation for Wide Fenders - Optional (continued)

Fenders for 560, 600 & Dual Tire Sizes

Use these hole locations when using larger tires sizes (560, 600 & Duals) for clearance purposes.

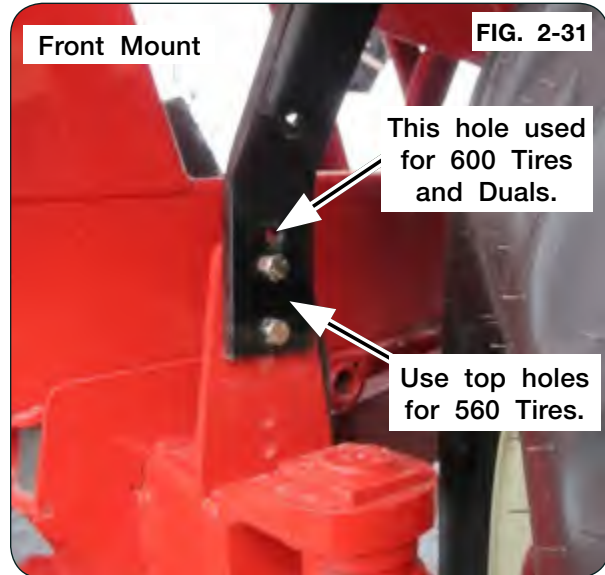
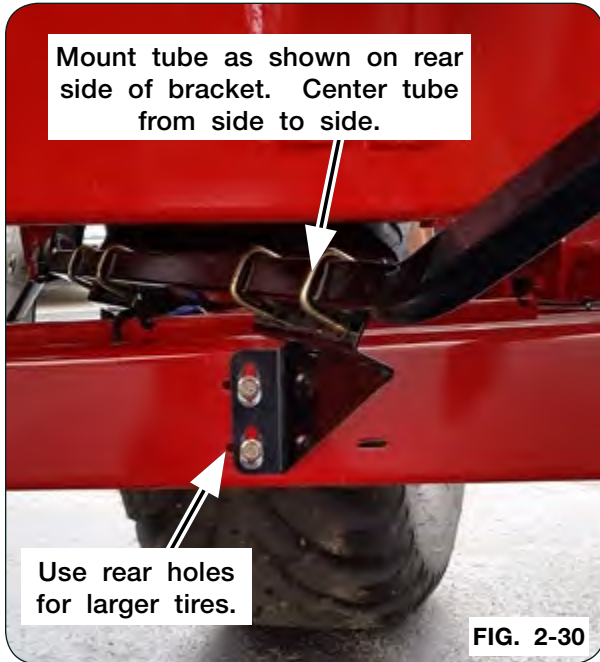

Fender Installation - Optional (continued)

WARNING

- EYE PROTECTION AND OTHER APPROPRIATE PERSONAL PROTECTIVE EQUIPMENT MUST BE WORN WHILE SERVICING IMPLEMENT.

Fender Light Installation - Optional

1. Center mounting bezel in molded fender relief. Once located, use mounting bezel as a template and drill two $\frac{3}{16}$ " diameter mounting holes thru fender. See figure 1.
2. Remove mounting bezel and measure $\frac{7}{8}$ " from most rearward hole (farthest from fender front edge) to locate third hole, see figure 2. Mark location and drill a $1 \frac{1}{16}$ " diameter hole. See figure 3.

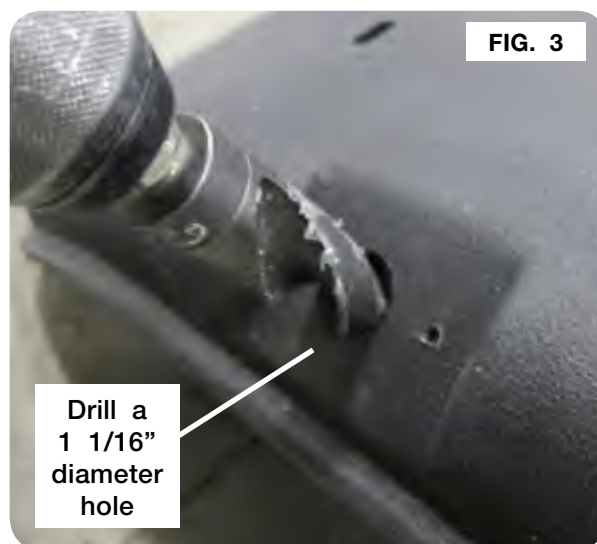
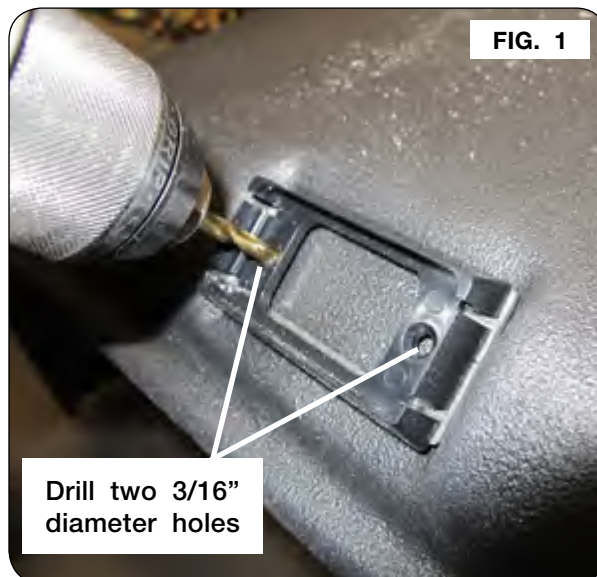
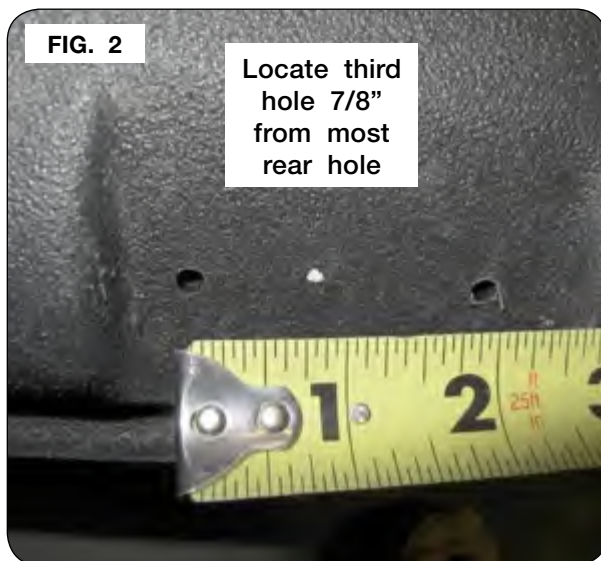

Fender Installation - Optional (continued)

Fender Light Installation - Optional

3. Assemble mounting bezel to fender using provided hardware. Position light terminals over 1/16" diameter hole and push light into mounting bezel for a snap fit, see figure 4. On the underside of fender, align the wire terminal harness to the light and firmly push-on. See figure 5.

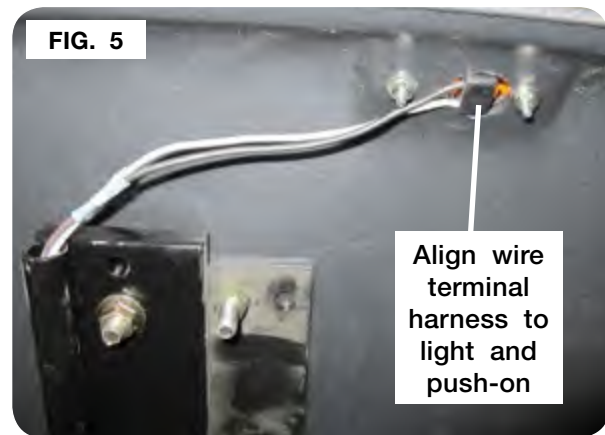

Fender Installation - Optional (continued)

Fender Light Installation - Optional (continued)

4. Locate front and rear fender harness center break-out leads over main harness leads on the running gear center pull tube and connect the same color wires. Route harness leads along running gear brace structures and up along each fender mounting bracket and conduit tube.

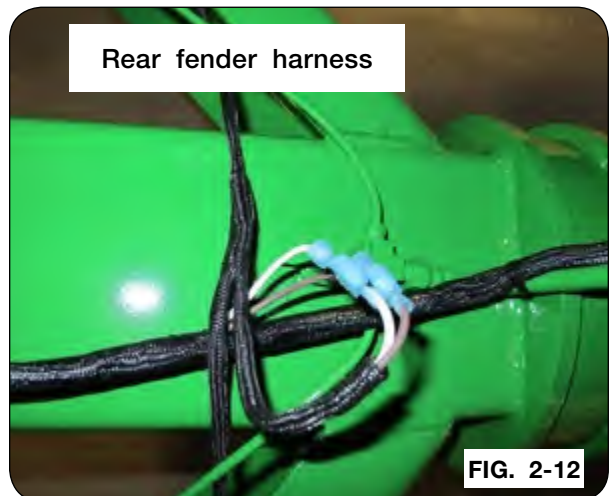
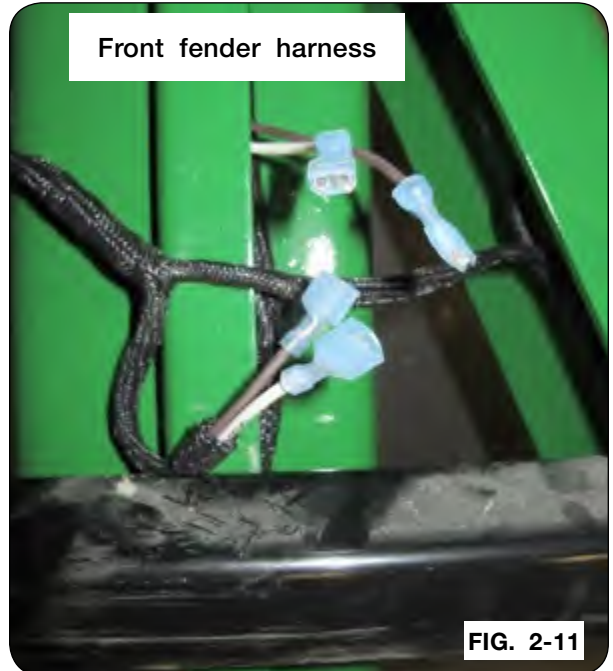

5. Connect each light terminal lead to light harness leads with butt connectors, see FIG. 2-13. Connect main harness to tractor and turn on tail lights to confirm fender light operation.

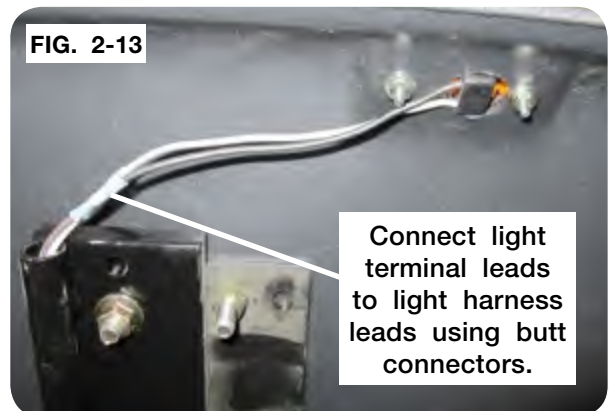

Fender Installation - Optional (continued)

Wiring (Where Applicable)

6. Install perimeter wiring harness and connect to main harness. Crimp light wires to harness connectors. Assemble lights to fenders, with ground eyelets on mounting bolts.
7. Connect electrical system to power source and check for proper operation.

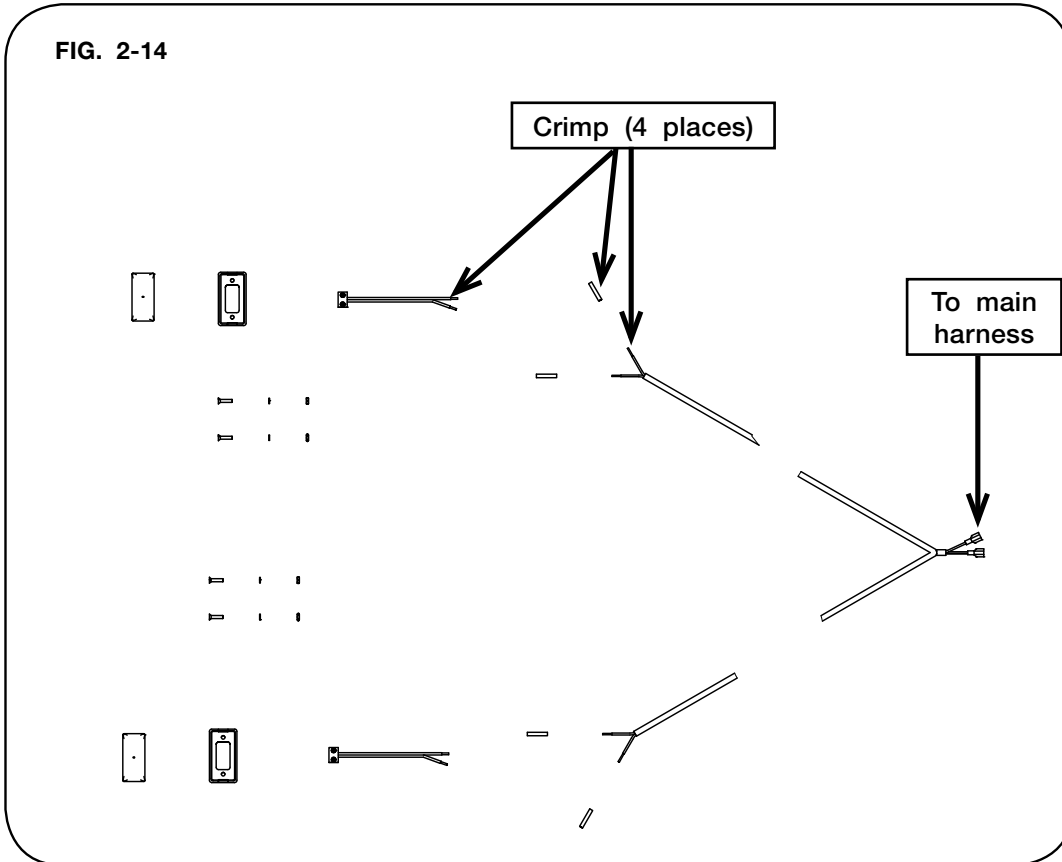

Weather Guard Tarp Installation - Optional

⚠ WARNING

- **FALLING OBJECTS CAN CAUSE SERIOUS INJURY OR DEATH. DO NOT WORK UNDER THE MACHINE AT ANY TIME WHILE BEING HOISTED. BE SURE ALL LIFTING DEVICES AND SUPPORTS ARE RATED FOR THE LOADS BEING HOISTED. THESE ASSEMBLY INSTRUCTIONS WILL REQUIRE SAFE LIFTING DEVICES UP TO 250 LBS. SPECIFIC LOAD RATINGS FOR INDIVIDUAL LOADS WILL BE GIVEN AT THE APPROPRIATE TIME IN THE INSTRUCTIONS.**
- **EYE PROTECTION AND OTHER APPROPRIATE PERSONAL PROTECTIVE EQUIPMENT MUST BE WORN WHILE SERVICING IMPLEMENT.**
- **TIPPING OR MOVEMENT OF THE MACHINE CAN CAUSE SERIOUS INJURY OR DEATH. BE SURE MACHINE IS SECURELY BLOCKED.**
- **TO PREVENT PERSONAL INJURY OR DEATH, ALWAYS ENSURE THAT THERE ARE PEOPLE WHO REMAIN OUTSIDE THE WAGON TO ASSIST THE PERSON WORKING INSIDE, AND THAT ALL SAFE WORKPLACE PRACTICES ARE FOLLOWED. THERE IS RESTRICTED MOBILITY AND LIMITED EXIT PATHS WHEN WORKING INSIDE THE IMPLEMENT.**

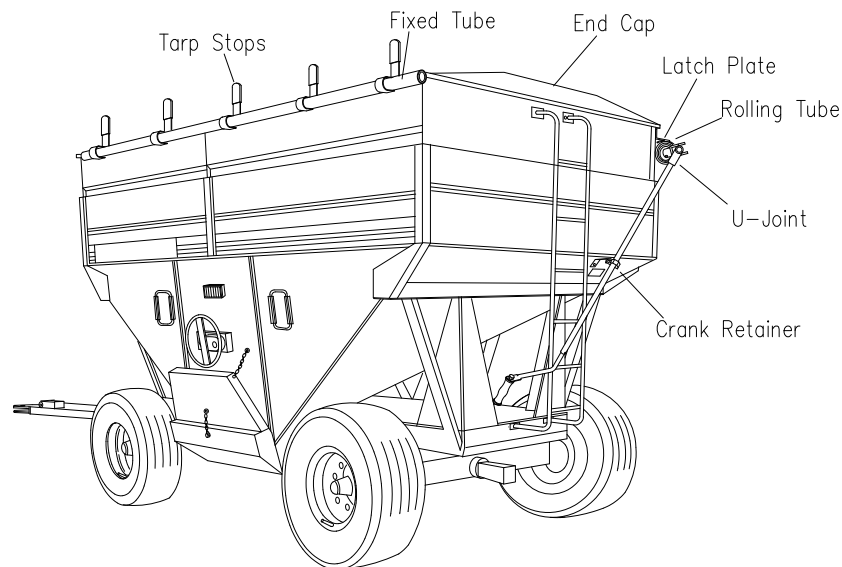

FIG. 2-15

1. Install the side board extensions to the box.
2. Assemble the end caps (300494B) to the front and rear side boards with flange screws (95585) and flange nuts (91263). Fasten to right and left side boards with 1/4 x 1 self-drilling screw (9512). See FIG. 2-16.

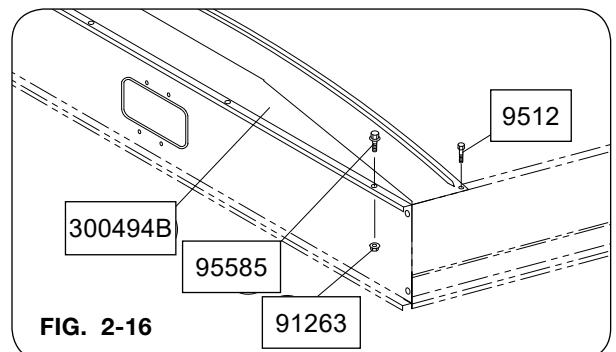

FIG. 2-16

Weather Guard Tarp Installation (continued)

3. Assemble the bow brackets and latch plates:

Models Using Bow Brackets - 300977B

Assemble bow brackets (300977B) and latch plate to the right side panel or side board with torx head screw (9005312) and flange nut (91263). Secure to side board using capscrew (9388-051) and flange nut (91263). See Figure 2-17

Models using Bow Brackets - 283425B

Assemble the bow brackets (283425B) to the inside, right hand side of the wagon with 5/16"-18UNC x 3/4" large flange screws (91256) and 5/16"-18UNC flange nuts (91257). See Figure 2-18.

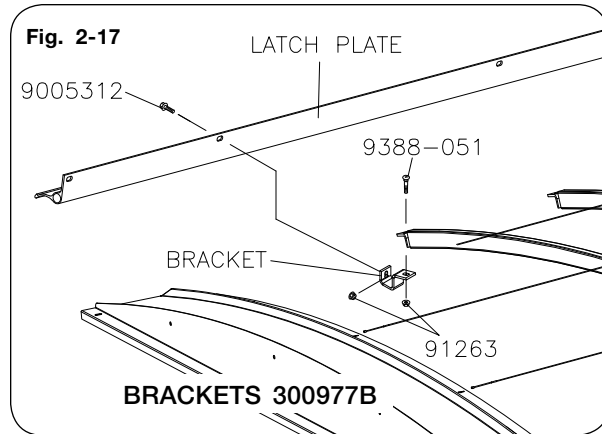

Attach the latch plates to the outside, right-hand side of the wagon with 3/8"-16UNC x 1" truss head screws (9005312), 3/8"-16UNC large flange nuts (91263), and through the bow bracket (283425B). See Figure 2-18.

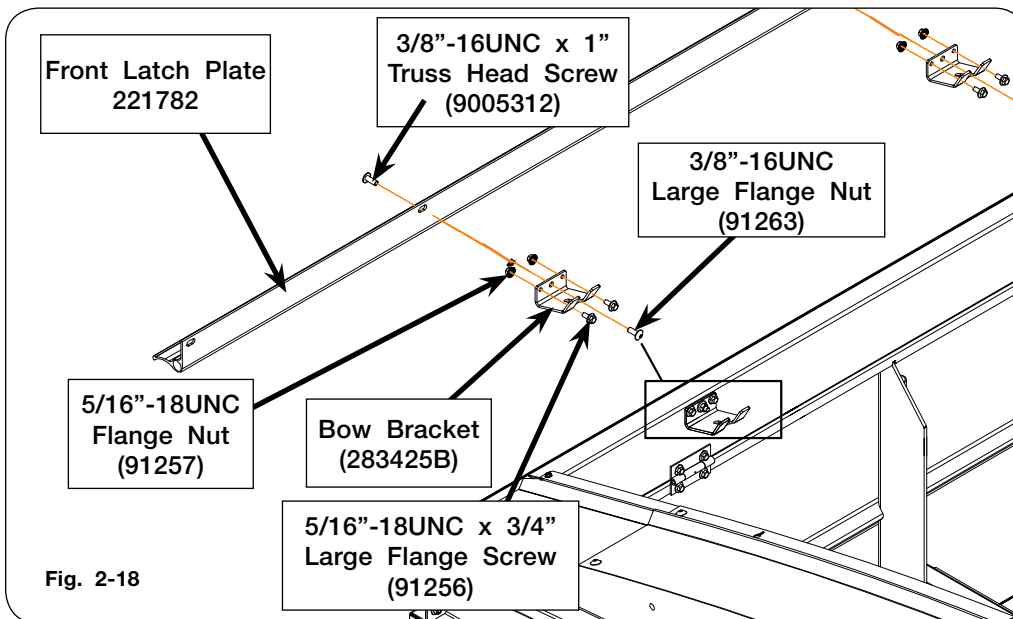

Weather Guard Tarp Installation - Optional (continued)

- Secure latch plate to front of panel with eyebolt (9004548) and two flange nuts (91263). See Figure 2-19.

The latch plates are divided in the center of the wagon with pre punched holes for ease of assembly. Locate the front and rear latch plates. Looking at the right side of the wagon, position the front latch plate on the front right sideboard. The holes should line up with the existing tarp bow holes. Use the provided hardware to attach the latch plates. Repeat for rear latch plate.

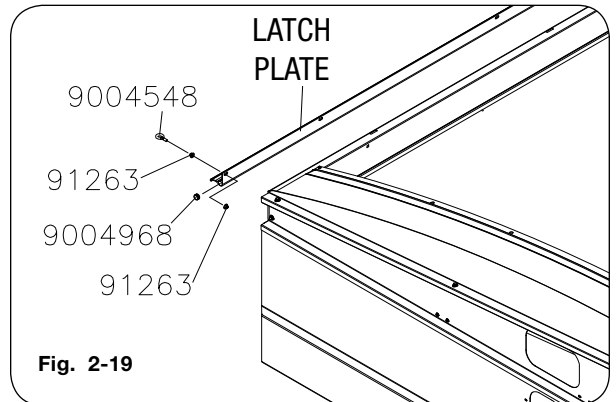

NOTE: If holes are not drilled in the sideboards or panels for attaching latch plates, locate the hold position by attaching latch plates to the right side panel or boards using the existing bow bracket holes and provided hardware. Drill the necessary holes with 7/16" drill bit through the center of the open slots of the latch plate. Finish assembling the latch plate with the provided hardware.

- Assemble the tarp bows:

Models Using Tarp Bows - 301210B

Assemble the tarp bows (301210B) to the left side panels or sideboards with carriage bolts (9388-051) and flange nuts (91263). See Figure 2-20.

Models Using Tarp Bows - 301208B

Assemble the tarp bows (301208B) to the bow mounting brackets with countersunk cap-screws (902703-046) and flange nuts (91263). See Figure 2-21.

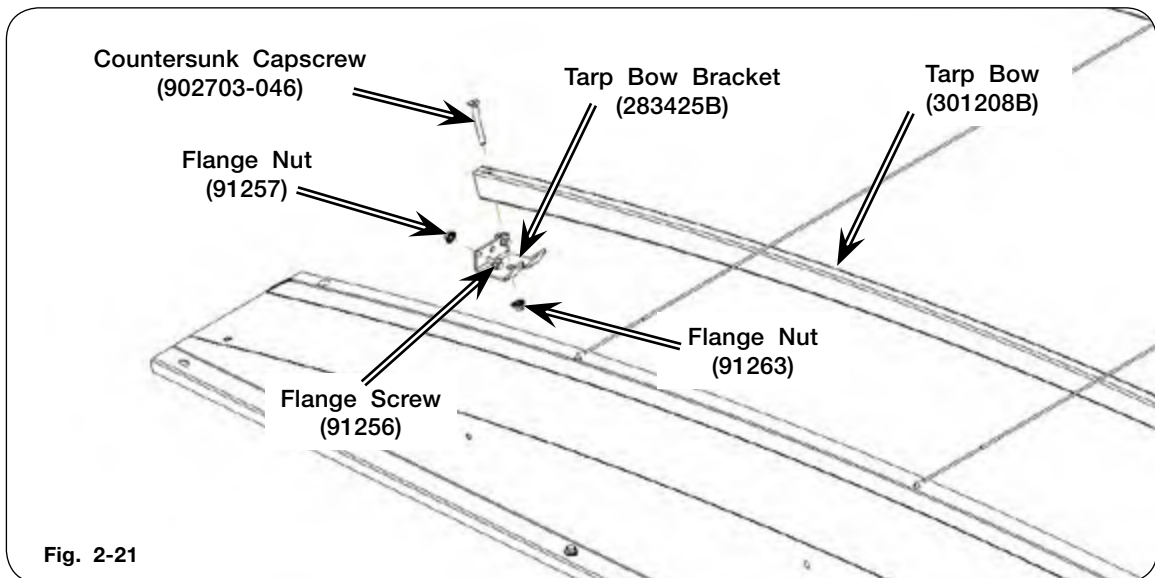
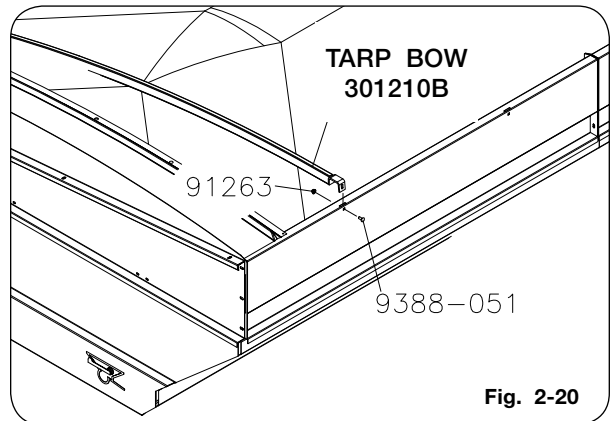

Weather Guard Tarp Installation (continued)

NOTE: Ensure countersunk capscrews (902703-046) are flush with the top of bow weldment (301208B). See Figure 2-22.

6. Tighten all hardware.

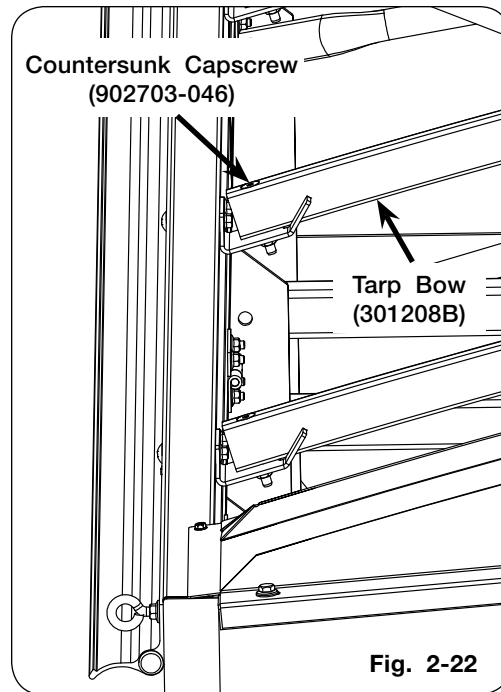

Weather Guard Tarp Installation - Optional (continued)

- Attach the cable assemblies (9005707) to the rear end cap holes, see FIG. 2-24. Run cables over the top of the bows (301208B - SN B37690100 & Up; 301210B - SN B37690099 & Lower). Route cables through holes in front end caps (FIG. 2-23). Insert capscrew (TA0-907131-0) through hole in front end cap and into bracket with U-nut assembly (281712B). Secure cables to the slot in bracket assembly (281712B) (FIG. 2-26). To tighten cables, tighten capscrew (TA0-907131-0) on outside of wagon until bracket makes cables snug tight. **Do not overtighten.** Plug the remaining holes in the rear end cap with plug (9005727).

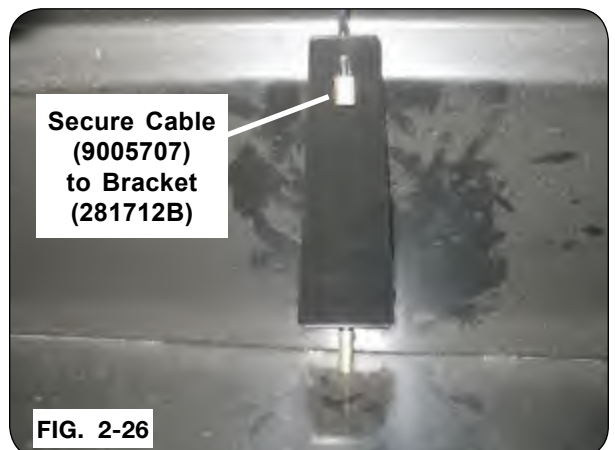
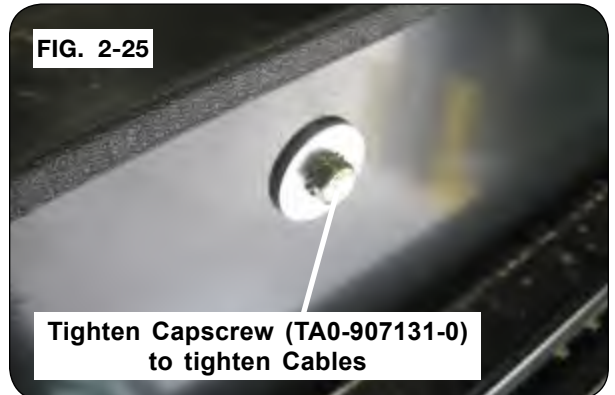
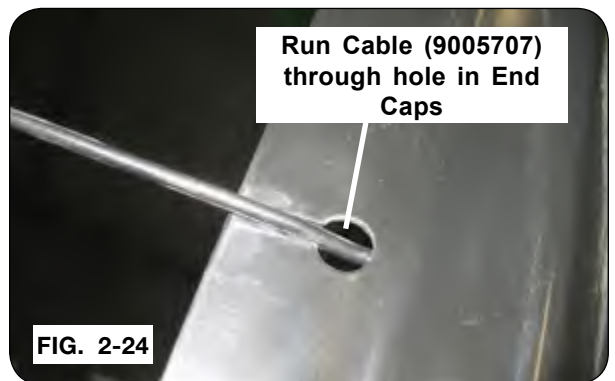
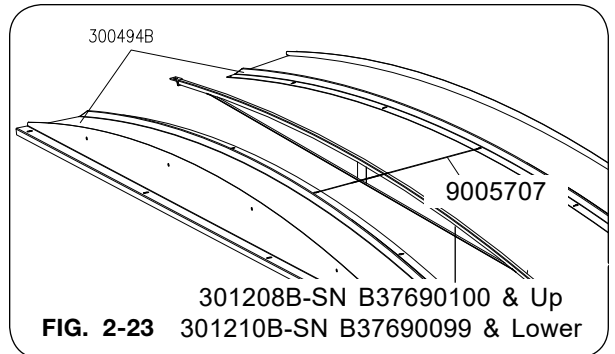

Weather Guard Tarp Installation - Optional (continued)

8. (2-person operation) On a clean floor, lay the tarp out flat with the raw edge of the hems and pockets down and the exterior side facing up.
9. Insert the small 1 1/8" fixed tube weldment by sliding it into the small pocket of the tarp. Leave 1" of the tube sticking out one end and drill a 3/16" hole through the center of the outer reinforcement strap and tube. Fasten with a rivet (9003378). At the other end, pull on the tarp by hand to stretch it until there is 1" of tube sticking out. Drill hole and install rivet. Press the 1 1/8" plugs (9005088) into each end of the tube. See Fig. 2-27.

INSTALLATION TIP:

Tarp is designed to be stretched the length of the tube to reduce wrinkling. For easier assembly apply liberal dusting of baby powder on tube and inside of tube pockets before sliding tubes in pockets.

10. Insert the 2" roll tube into the large pocket, with the splined shaft to the rear. Measure 10 1/2" from the end of the spline to the start of the tarp. Install the first U-clamp (9004949) and self-drilling screws (9005197) to the first reinforcement strap, to secure the tarp to the tube. Work down the roll tube putting the U-clamps and self-drilling screws on each reinforcement strap. Make sure to keep the tarp pulled tight to reduce wrinkling. See Fig. 2-27.

Grain wagons with any unused holes on the side of the wagon need to be plugged. Use pre-drilled 1/8" locator holes in the right-hand side of the wagon. Install with 1/4" self-tapping screws and nuts provided.

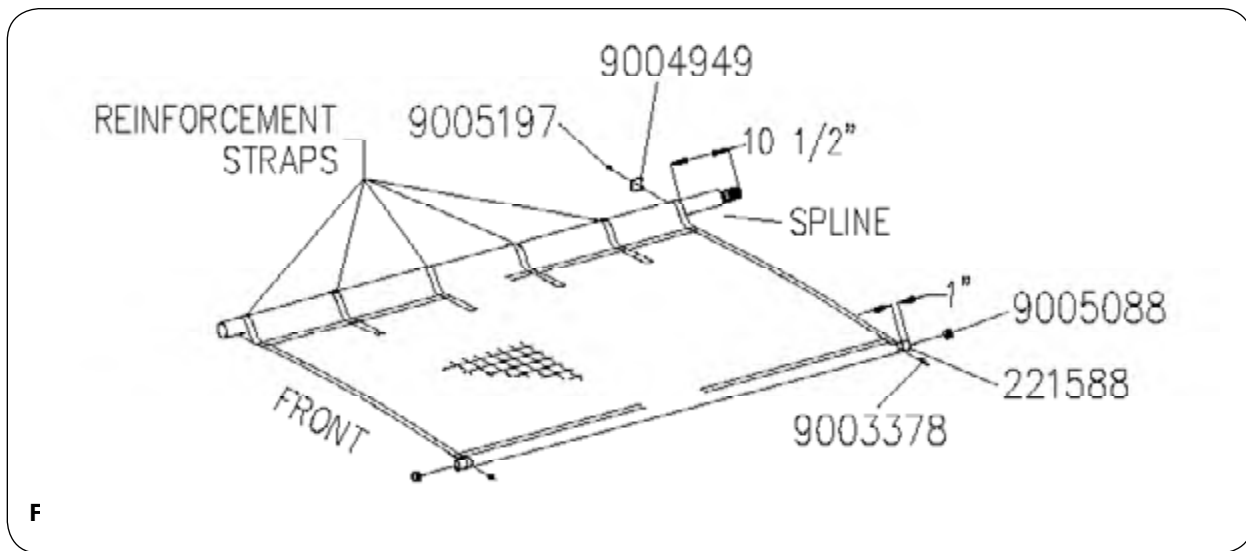

Weather Guard Tarp Installation - Optional (continued)

11. Insert knotted stretch rope (221722) through flat washer (9405-074), plastic tube (221668) and end plug (9004947). Place these items as an assembly into front end of 2" roll tube weldment and press the end plug into the end of the tube. Screw self-drilling screw (9001396) through the side of roll tube, into end plug (9004947) to retain plug into tube. Slide hose (TA806225) over bungee. See Fig. 2-28.

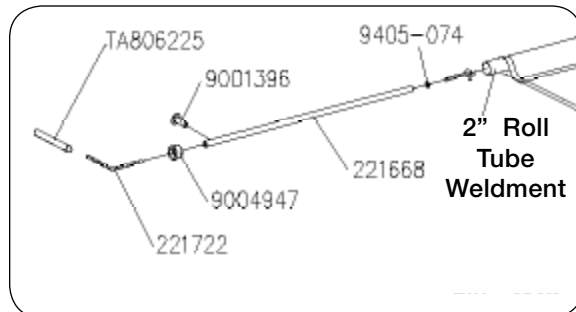

12. Using an appropriate lifting device rated at a minimum of 250 lbs., position the tarp on top of the left side of the wagon. Hand roll the tarp into open position. Place the 1 1/8" stationary tube side of the tarp on top of the left side of the box, centered from front to back of box. BE CAREFUL NOT TO LET THE TARP ROLL OFF OF THE BOX. Assemble the tarp and stops (266689B) (with caps) to the left side boards by poking a hole through the tarp and using flange screws (91262) and flange nuts (91263). Assemble the center stops through each bow weldment, the front and rear stops should be approximately 1 foot in from the ends of the wagon. See Fig. 2-29.

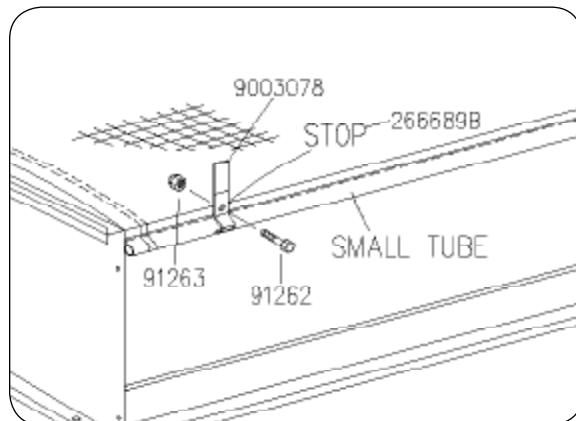

13. Unroll the tarp making sure hose (TA806225) remains over end of stretch cord. Insert stretch cord through the top of the eye bolt (9004548). With the tarp rolled up under the latch plate, leave 2 or 3 inches of slack in the stretch cord and knot below the eyebolt. Cut off additional cord a couple inches below the knot. To keep cord from fraying, use a lighter to heat and sear loose strands. See Fig. 2-30.

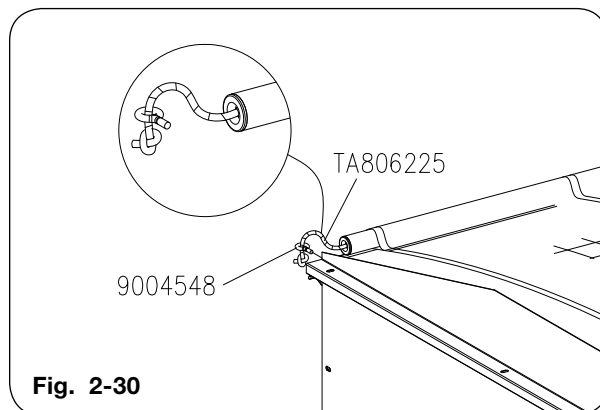
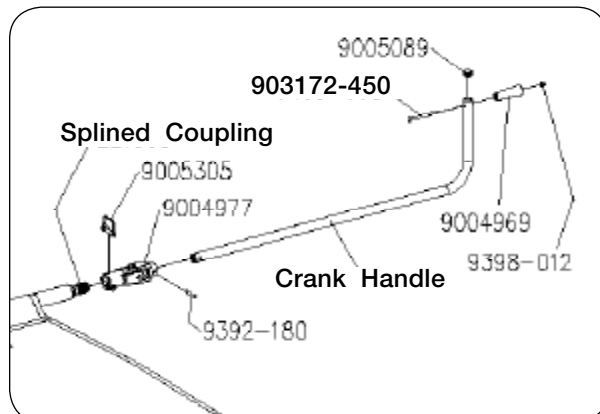

Fig. 2-30

14. Insert U-joint (9004977) over splined coupling and secure with wire lynch pin (9005305). Insert crank handle into U-joint and secure with roll pin (9392-180). Insert round head bolt (903172-450) into bottom hole of crank handle (221748) and slide plastic handle (9004969) onto bolt securing with locknut (9398-012). Insert 1 1/4" plug (9005089) into end of handle. See Fig. 2-31.



Weather Guard Tarp Installation - Optional (continued)

Hand Crank Handle

15. Locate the bracket just above the box fold line, centered on the box. Using self-tapping screws (96972) mount bracket to box and secure using flange nut (91263). Attach handle holder (220579B) to bracket (221770B) using capscrew (9390-055) and locknut (9928). See Fig. 2-32

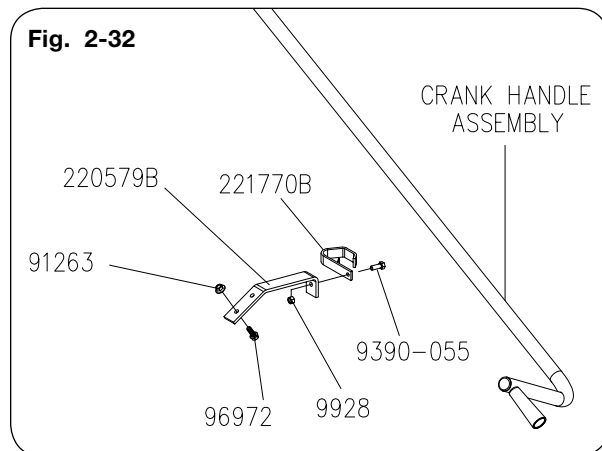

16. Tighten tarp by holding the crank firmly with both hands and roll the main tarp tube counter-clockwise up under the latch plate. Next, bring the crank handle down perpendicular to the ground. Continue by lifting it up into the crank retainer. See Fig. 2-33.

NOTE: A slight bow in crank tube should indicate adequate tension.

NOTE: U-joint may need to be re-indexed on the splined shaft of the roll tube to achieve an ideal tarp tension and that over time it may need to be readjusted.

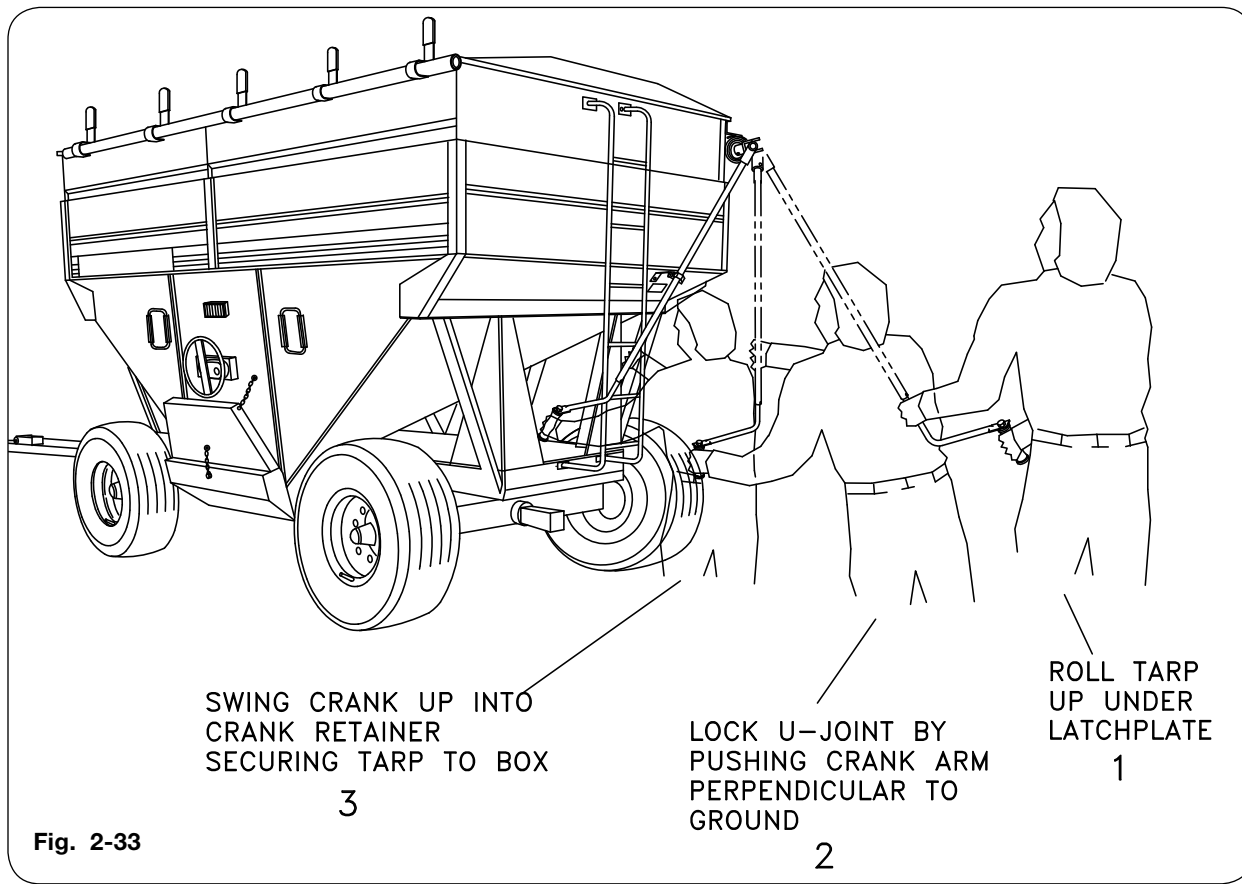

SECTION III

Operation

Tandem Operation	3-2
Chute.....	3-3
Weather Guard Tarp Operation	3-4

Tandem Operation

When pulling wagons in the tandem option, please do the following:

1. Connect the electrical cord.
2. Hook up the safety chain on the lead wagon that is sized for the total load.
4. Allow enough slack for turning oscillation in the field. Be sure to prevent the electrical cord from dragging or catching.



Chute

The operator should check to assure the chute is in the transport position and in the latch prior to transporting. Adjust the rubber bumper so there is adequate pressure on the latch so it will not unlatch when being pulled.

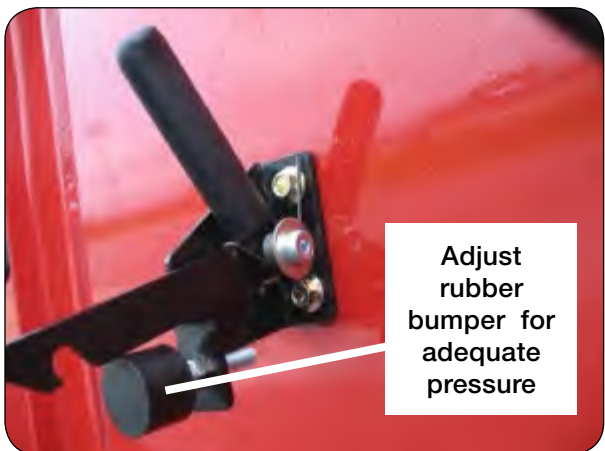

Weather Guard Tarp

WARNING

- **TO PREVENT PERSONAL INJURY OR DEATH, DO NOT ALLOW ANYONE ON A CLOSED TARP. TARP SYSTEM IS NOT DESIGNED TO SUPPORT A PERSON.**
- **FALLING OBJECTS CAN CAUSE SERIOUS INJURY OR DEATH. REMOVE ACCUMULATED WATER/SNOW/ICE OR ANY OTHER OBJECTS FROM TARP BEFORE OPENING TARP.**

IMPORTANT

- *Do not open or close tarp while moving or in high wind conditions. Damage to the tarp may occur.*
- *Tarp should not be used if it is torn or the bungee cords are frayed or show damage. If water pools on the tarp, adjust tension of tarp cables and/or arm springs as required.*

Always use adequate caution when operating tarp.

Make sure tarp is open before unloading or loading.

Make sure nobody is near the tarp system before and during operating.

Do not operate tarp with wagon hoisted in an elevated position.

If tarp is covered with snow, it is important to remove snow before operating.

End caps must be free from grain that may be piled on them. Grain should not be heaped higher than the end caps or tarp bows.

Tarp may be fully opened or completely closed while in transit. However, the closed position is recommended.

Ensure everyone who operates the tarp is familiar with the correct procedures outlined in this manual.

Weather Guard Tarp (continued)

Procedure

1. Using both hands, carefully remove crank from holder.
2. Roll tarp to the desired location, choosing either a fully open or fully closed position.
3. To close the tarp, roll the main tarp tube clockwise up under the latch plate. Next, bring the crank handle down perpendicular to the ground. Continue by lifting it up into the crank retainer.

NOTE: A slight bow in crank tube should indicate adequate tension.

NOTE: Crank U-joint may need to be re-indexed on tarp tube to achieve correct tension.

4. Place crank in holder.
5. To open tarp, turn the main tarp tube counter clockwise until the tarp is fully open. Place crank in crank holder.

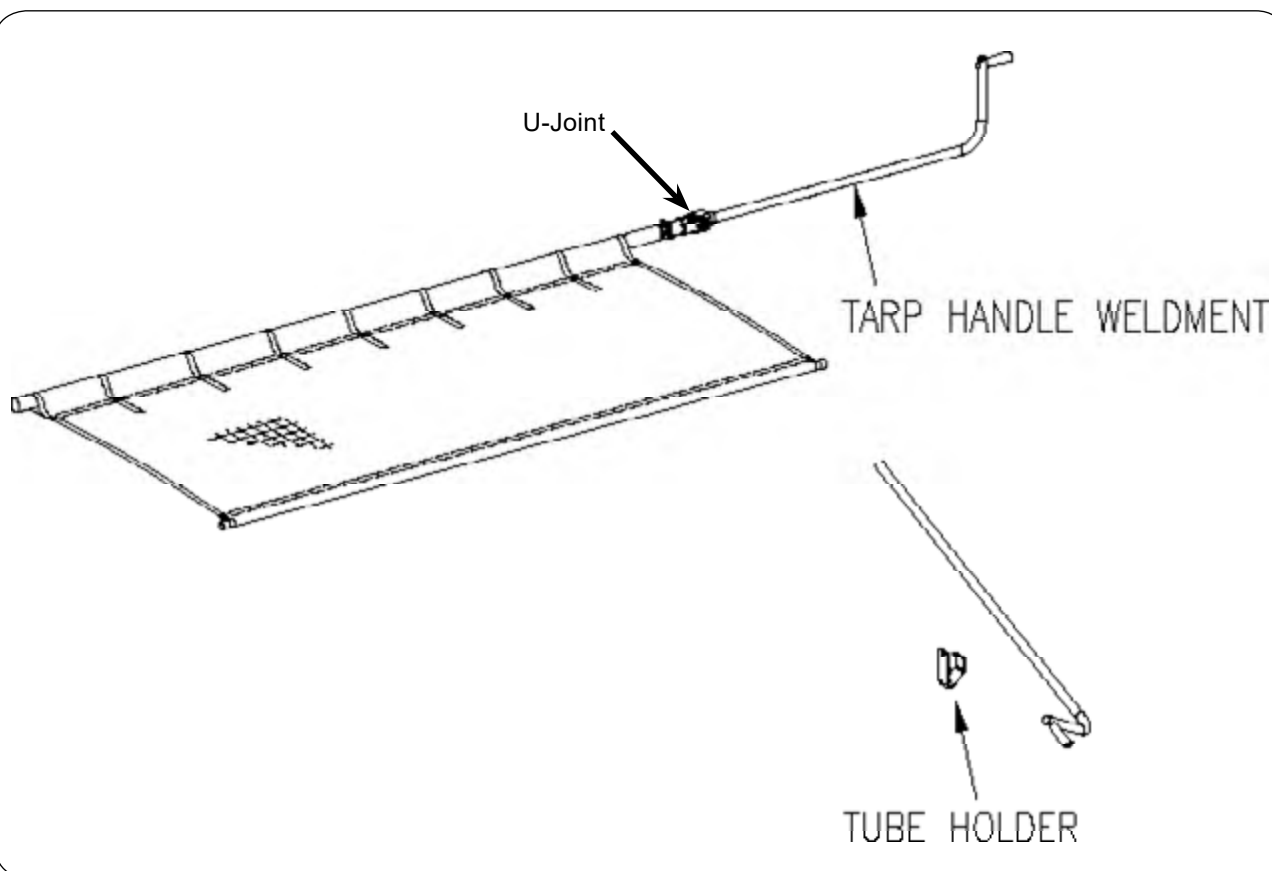

Notes

SECTION IV

Maintenance

Seasonal Storage	4-2
Electrical Schematic.....	4-3
Wheels & Tires	
Wheel Nut Torque Requirements.....	4-4
Tire Pressure	4-5
Tire Warranty	4-5
Complete Torque Chart	
Capscrews - Grade 5	4-6
Brake Line Fittings - Torque and Installation	4-7
13"Surge Brake Information	
Brake Shoe Adjustment.....	4-8
Brake Shoe Centering	4-9
Brake System Troubleshooting Guide	4-11
Tarp Troubleshooting	4-12
Inspection and Maintenance.....	4-12

Seasonal Storage

Your wagon is an important investment. Spend a little time to protect it from destructive rust and corrosion. You will be repaid in longer service life and better performance.

Do the following before placing the wagon in storage:

1. Remove dirt and trash which could cause rusting.
2. Wash the wagon if it was used to haul corrosive materials such as fertilizer.
3. Remove the tongue cover and use compressed air to remove debris from the retractable cord assembly area.
4. Repaint any chipped or scraped areas.
5. Check the brake fluid level.
6. Wheel hubs - check grease after first season of use.
7. Inspect for damage or worn parts, replace before next season.
8. Store the wagon inside, away from animals.
9. Replace all worn, torn or faded decals and reflectors.
10. Fully open the door to remove any remaining grain, and allow the moisture to drain.

Electrical Schematics

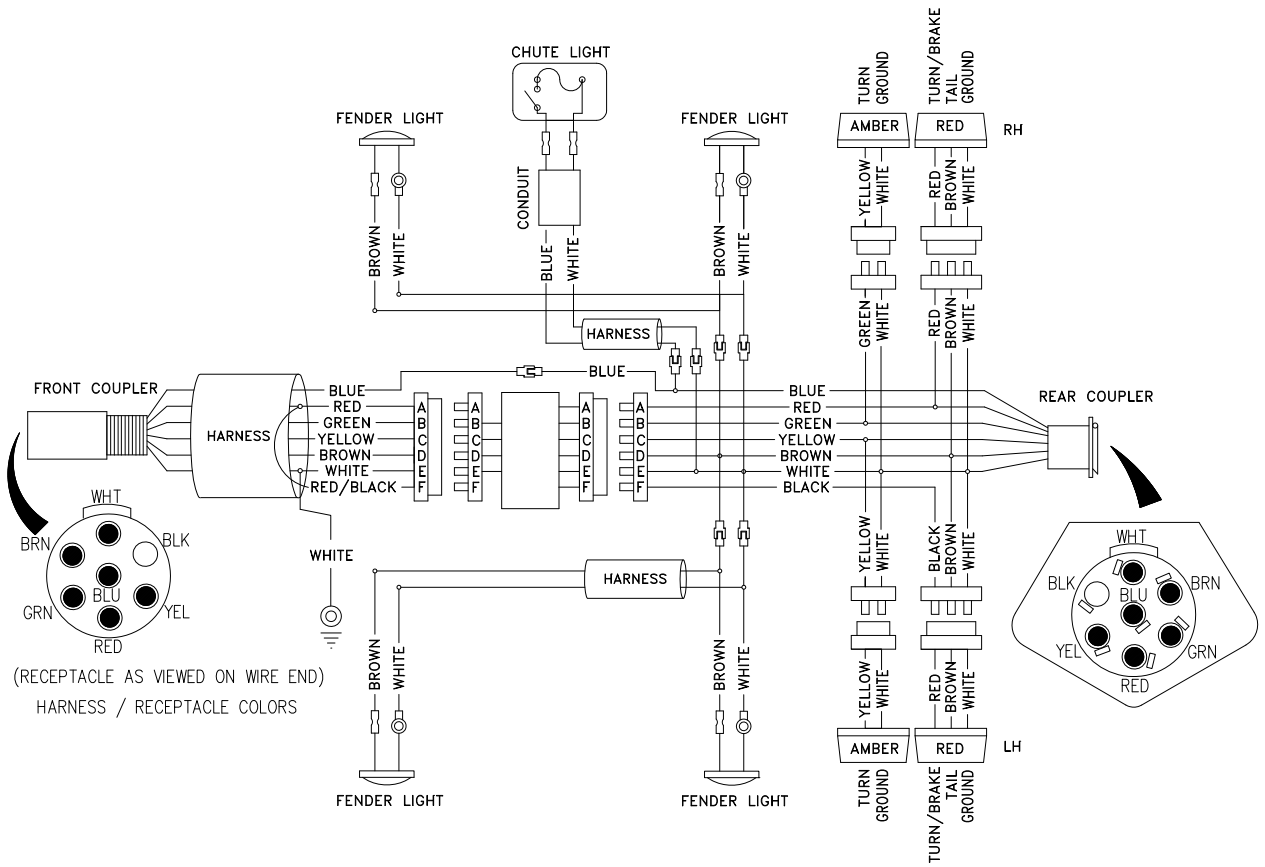

Wheels and Tires

Wheel Nut Torque Requirements

⚠ CAUTION

- IMPROPERLY TORQUED WHEEL NUTS/BOLTS CAN CAUSE A LOSS OF IMPLEMENT CONTROL AND MACHINE DAMAGE. TORQUE WHEEL NUTS/BOLTS TO VALUES IN TABLE. CHECK TORQUE BEFORE USE, AFTER ONE HOUR OF UNLOADED USE OR AFTER FIRST LOAD, AND EACH LOAD UNTIL WHEEL NUTS/BOLTS MAINTAIN TORQUE VALUE. CHECK TORQUE EVERY 10 HOURS OF USE THERE-AFTER. AFTER EACH WHEEL REMOVAL START TORQUE PROCESS FROM BEGINNING. WARRANTY DOES NOT COVER FAILURES CAUSED BY IMPROPERLY TORQUED WHEEL NUTS/BOLTS.

Failure to check torque before first load may damage wheel nut/bolt seats. Once seats are damaged, it will become impossible to keep nuts/bolts tight. Tighten nuts/bolts to applicable torque value shown in table. Start all nuts/bolts by hand to prevent cross threading. Torque nuts/bolts in the recommended sequence as shown in Diagram 1.

WHEEL HARDWARE	
SIZE	FOOT-POUNDS
3/4-16 (UNF)	365 ft.-lbs.

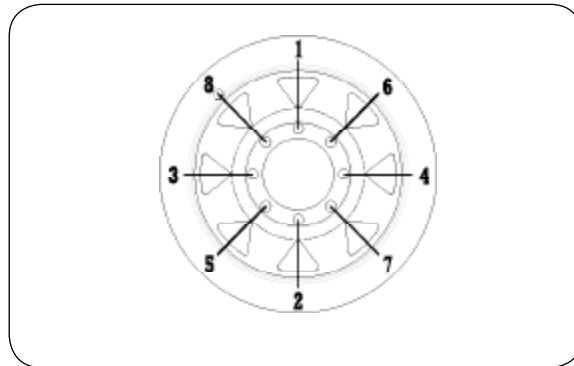

8 BOLT
DIAGRAM 1

Wheels and Tires (continued)

Tire Pressure

- The following is to be used as a general guide for tire inflation and figures can vary depending on the specific tire size used. It is important that tires are inspected after unit is loaded. Start with pressure indicated by your tire size and bushel capacity. The tire should stand up with no side-wall buckling or distress as tire rolls. Record the pressure needed to support the full load and maintain this pressure to achieve proper tire life. Do not exceed maximum recommended tire pressure* or maximum rated speed**.

**RECOMMENDED
TIRE PRESSURES**

TIRE SIZE	LOAD INDEX/ PLY RATING	MAX PSI				
		450 BU	550 BU	625 BU	650 BU	750 BU
385/65R22.5 (Used Tire)		65 psi	65 psi	-	-	-
425/65R22.5 (Used Tire)		65 psi	65 psi	85 psi	85 psi	-
445/65R22.5 (Used Tire)		-	65 psi	85 psi	85 psi	-
455/55R22.5 (Used Tire)		-	-	85 psi	85 psi	85 psi
460/65R22.5 (New Tire)	168A8	-	58 psi	66 psi	68 psi	73* psi
560/65R22.5 (New Tire)	161D	-	-	56** psi	56** psi	56** psi
600/50-22.5 (New Tire)	169A8	-	-	-	-	46** psi
315/80R22.5 (Used Tire)		-	-	-	-	85 psi

***MAX psi @ 19 mph**

**** MAX psi @ 25 mph**

Tire Warranty

For questions regarding new tire warranty, please contact your local original equipment tire dealer. **USED TIRES CARRY NO WARRANTY.**

Complete Torque Chart

Cap screws - Grade 5

NOTE:

- Grade 5 cap screws can be identified by three radial dashes on the head.
- For wheel torque requirements, refer to **Wheels and Tires**.
- Tighten U-bolts evenly and equally to have the same number of threads exposed on each end.

SIZE	FOOT POUNDS	NEWTON METERS
1/4-20	8-10	11-13
1/4-28	9-11	12-15
5/16-18	15-17	20-23
5/16-24	17-19	23-26
3/8-16	25-28	34-38
3/8-24	28-31	38-42
7/16-14	40-45	54-61
7/16-20	45-50	61-68
1/2-13	62-68	84-92
1/2-20	68-75	92-102
9/16-12	90-98	122-133
9/16-18	100-110	134-148
5/8-11	120-135	162-183
5/8-18	124-137	168-186
3/4-10	200-220	270-300
3/4-16	210-230	285-310
7/8-9	330-350	425-475
7/8-14	360-380	460-515
1-8	500-525	675-710
1-14	540-560	730-760
1 1/8-7	600-635	815-860
1 1/8-12	665-700	920-950
1 1/4-7	850-895	1150-1215
1 1/4-12	940-990	1275-1340
1 3/8-6	1125-1175	1525-1590
1 3/8-12	1280-1335	1735-1810
1 1/2-6	1500-1560	2035-2115
1 1/2-12	1685-1755	2285-2380

IMPORTANT

- Follow these torque recommendations except when specified in text.

Brake Line Fittings - Torque and Installation

INVERTED FLARE

1. Lubricate threads and assemble to fitting body. Nut should be turned hand tight.
2. Tighten assembly with wrench until a solid feeling is encountered. From that point, apply a one-sixth turn.

NOTE: Do not over-torque as it may damage the fitting or split the tubing at the flare.

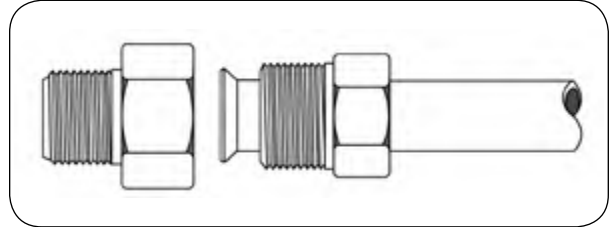

Brake System

Brake Shoe Adjustment

WARNING

- FALLING OBJECTS CAN CAUSE SERIOUS INJURY OR DEATH. DO NOT WORK UNDER THE MACHINE AT ANY TIME WHILE BEING HOISTED. BE SURE ALL LIFTING DEVICES AND SUPPORTS ARE RATED FOR THE LOADS BEING HOISTED. THESE ASSEMBLY INSTRUCTIONS WILL REQUIRE SAFE LIFTING DEVICES UP TO 12,000 LBS. SPECIFIC LOAD RATINGS FOR INDIVIDUAL LOADS WILL BE GIVEN AT THE APPROPRIATE TIME IN THE INSTRUCTIONS.
- EYE PROTECTION AND OTHER APPROPRIATE PERSONAL PROTECTIVE EQUIPMENT MUST BE WORN WHILE SERVICING IMPLEMENT.
- TIPPING OR MOVEMENT OF THE MACHINE CAN CAUSE SERIOUS INJURY OR DEATH. BE SURE MACHINE IS SECURELY BLOCKED.
- POTENTIAL ASBESTOS DUST HAZARD - SOME BRAKE LININGS MAY CONTAIN ASBESTOS DUST, WHICH HAS BEEN LINKED TO SERIOUS OR FATAL ILLNESSES. CERTAIN PRECAUTIONS NEED TO BE TAKEN WHEN SERVICING BRAKES:
 1. AVOID CREATING OR BREATHING DUST.
 2. AVOID MACHINING, FILING, OR GRINDING THE BRAKE LININGS.
 3. DO NOT USE COMPRESSED AIR OR DRY BUSHING FOR CLEANING (DUST CAN BE REMOVED WITH A DAMP BRUSH).

NOTE: Be sure to read preceding section on sliding hitch and latch adjustment before proceeding to this step.

Brakes are set at factory, however, it may become necessary to adjust shoes after the first season. The brakes incorporate a “Back-up” feature that makes it necessary to rotate the wheels in the direction of forward rotation only when making adjustments. Jack up each wheel. Tighten the brake adjusting cog nut (located in the slot on the brake backing plate) until you cannot rotate wheel by hand, then back off the adjustment until 3 - 4 threads are showing. And then additional threads may be necessary.

NOTE: If all 4 brakes are dragging, check tongue components to make sure parts work freely, nothing is binding or sticking.



13" Surge Brake Information

Brake Shoe Centering

(2 Person Operation ~ 15 to 20 Minutes Per Brake Assembly)

WARNING

- WHEN WORKING AROUND THE MACHINE, BE SURE IT IS SECURELY BLOCKED; FAILURE TO DO SO COULD RESULT IN TIPPING OR MOVEMENT OF MACHINE, CAUSING SEVERE BODILY HARM.
- EYE PROTECTION AND OTHER APPROPRIATE PERSONAL PROTECTIVE EQUIPMENT MUST BE WORN WHILE SERVICING IMPLEMENT.
- KEEP HANDS CLEAR OF PINCH POINT AREAS.

1. Park the empty wagon on a firm, level surface. Properly chock the tires not being serviced. Remove master cylinder cover on tongue of the wagon (Fig. 1 & 2). Make sure the master cylinder is not being actuated.
2. Use lifting device rated for 12,000 lbs. to lift the axle to allow the tire with the brakes needing adjustment to spin freely (Fig. 3). Loosen anchor pin nut on the back of brake assembly back plate with 1 1/8" socket (Fig. 4).

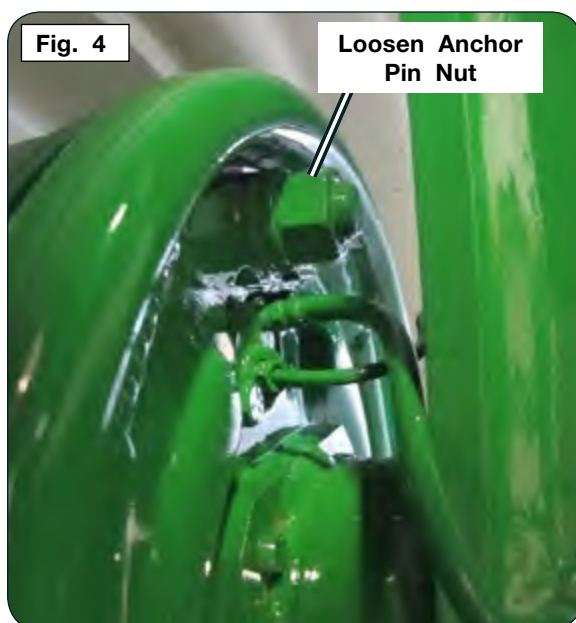
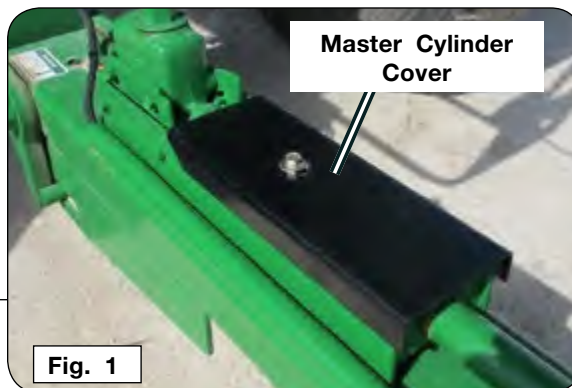

13” Surge Brake Information (continued)

3. Spin tire in direction of forward travel of the wagon. While tire is spinning, increase the brakes using the shoe adjustment star wheel until full contact of brakes can be heard (Fig. 5).
4. While tire is spinning, slowly apply and hold pressure to the master cylinder (Fig. 6). While holding pressure to the master cylinder, retighten anchor pin nut to 200-220 ft.-lbs (Fig. 7). This should center the brake shoe assembly within the brake drum.

NOTE: While applying pressure to the master cylinder, make sure the push tab remains vertical so parts can move freely when actuating the brakes. Refer to “Brake System — Troubleshooting Guide” in this section for additional information.

5. Release pressure to master cylinder. Spin tire in direction of forward travel of the wagon.
6. While tire is spinning, back off brake adjusting screw to 3.5 or 4 threads showing and apply master cylinder. Repeat this process until slight brake contact is heard. If brake contact is still severe, repeat steps 2-6 a second time.
7. Lower axle setting the tire on the ground. Install master cylinder cover. Remove chocks from tires.
8. Tow the unit for at least one mile applying the brakes several times. Periodically stop and feel the brake drums for excessive heat.
9. Adjust brake shoe adjustment screw in or out depending on feel of brakes.



Fig. 5



Fig. 6

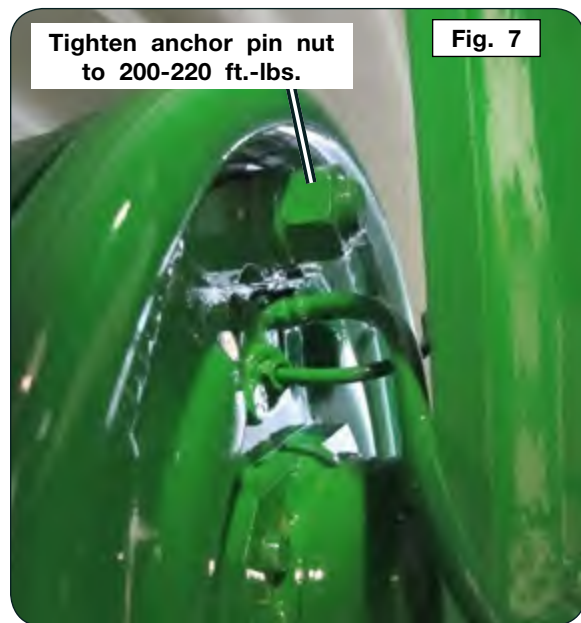

Fig. 7

Brake System - Troubleshooting Guide

SYMPTOM	REMEDY
BRAKES DRAGGING/LOCK-UP	1. Flush brake system
	2. Disassemble slave cylinders inside brake clusters. Clean cylinder and cylinder walls. Reassemble and adjust.
	3. Install new brake fluid.
BRAKE DRUMS HOT/ONE OR MORE BRAKES DRAG	1. Re-adjust brakes. Tighten brake shoes down to brake drum, then back off the adjustment until 3 - 4 threads are showing. And then additional threads may be necessary. Be sure each brake assembly has the same adjustment. This will equalize the brake system causing each brake to pull the same amount of weight.

IMPORTANT

- Position/rotate the push tube tab straight up/down so the parts can move freely when using the actuating brakes.

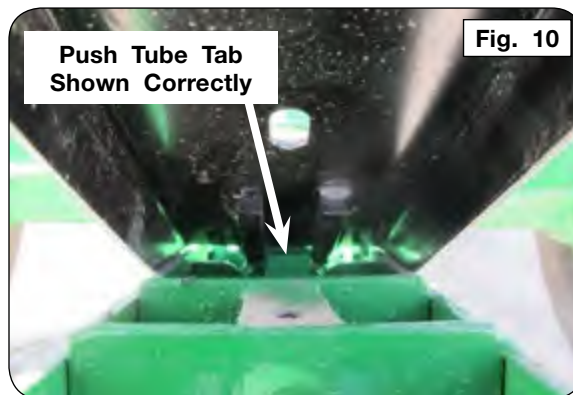
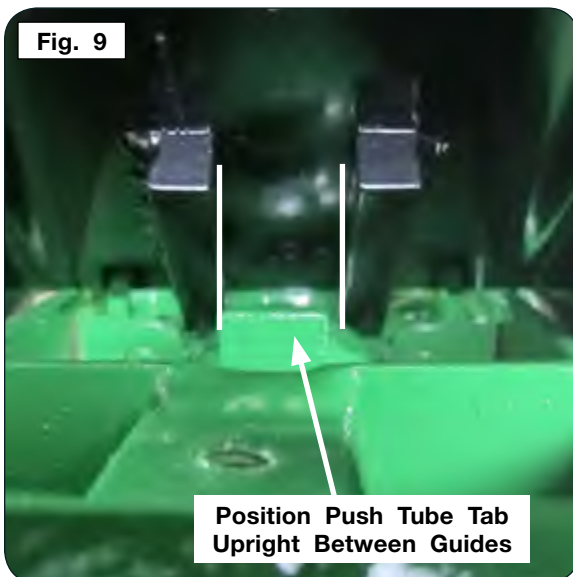
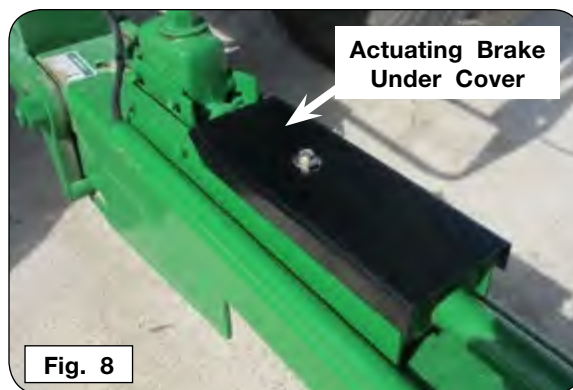

Tarp - Troubleshooting Guide

PROBABLE CAUSE	CORRECTION
Tarp sags in middle areas	1. Bows may be bent or adjusted too low.
	2. Missing or loose ridge strap. Replace or retighten.
	3. U-joint may need to be adjusted on splined shaft to provide more tension.
Holes or tears in tarp	1. Consult your local dealer for repairs.
	2. Order tarp repair kit from dealer.
	3. When new tarp or parts are needed always replace with original parts.

Tarp - Inspection and Maintenance

WARNING

- **TO PREVENT PERSONAL INJURY OR DEATH, DO NOT ALLOW ANYONE ON A CLOSED TARP. TARP SYSTEM IS NOT DESIGNED TO SUPPORT A PERSON.**
- **FALLING OBJECTS CAN CAUSE SERIOUS INJURY OR DEATH. REMOVE ACCUMULATED WATER/SNOW/ICE OR ANY OTHER OBJECTS FROM TARP BEFORE OPENING TARP.**

IMPORTANT

- *Do not open or close tarp while moving or in high wind conditions. Damage to the tarp may occur.*
- *Tarp should not be used if it is torn or the bungee cords are frayed or show damage. If water pools on the tarp adjust tension of tarp cables and/or arm springs as required.*

Periodic preventive maintenance should be practiced. Inspect tarp and hardware often for abrasions or loosened bolts that may need adjustment and/or repair. Check bungee cords for wear and adjust tension at the beginning of the season and again half way through the season. Cable spools are factory greased, but over time and use may require re-greasing.

Tears in tarp should addressed before further tarp operation. If water pools on tarp, adjust tension of tarp cables and/or arm springs.

If installed correctly, tarp should always operate as well as when first installed. If tarp does not pass this simple inspection, make all appropriate repairs or adjustments immediately before serious damage occurs.

SECTION III

Parts

Tongue.....	5-2
Undercarriage Components	5-4
Wheels and Tires.....	5-7
Brake Components.....	5-8
13" Brake Components	
Beginning with Serial #B33980100	5-10
Prior to Serial #B33980100.....	5-12
Gravity Box.....	5-14
Fender Components	5-16
Fender Light Components.....	5-18
Door Wheel with Gear Reduction.....	5-20
Kick Back Chute and SMV Components.....	5-22
Chute and Latch Components.....	5-24
Decals	5-26
Touch-Up Paint.....	5-27
Electrical Components.....	5-28
Weather Guard Tarp Components - Optional.....	5-30

Tongue

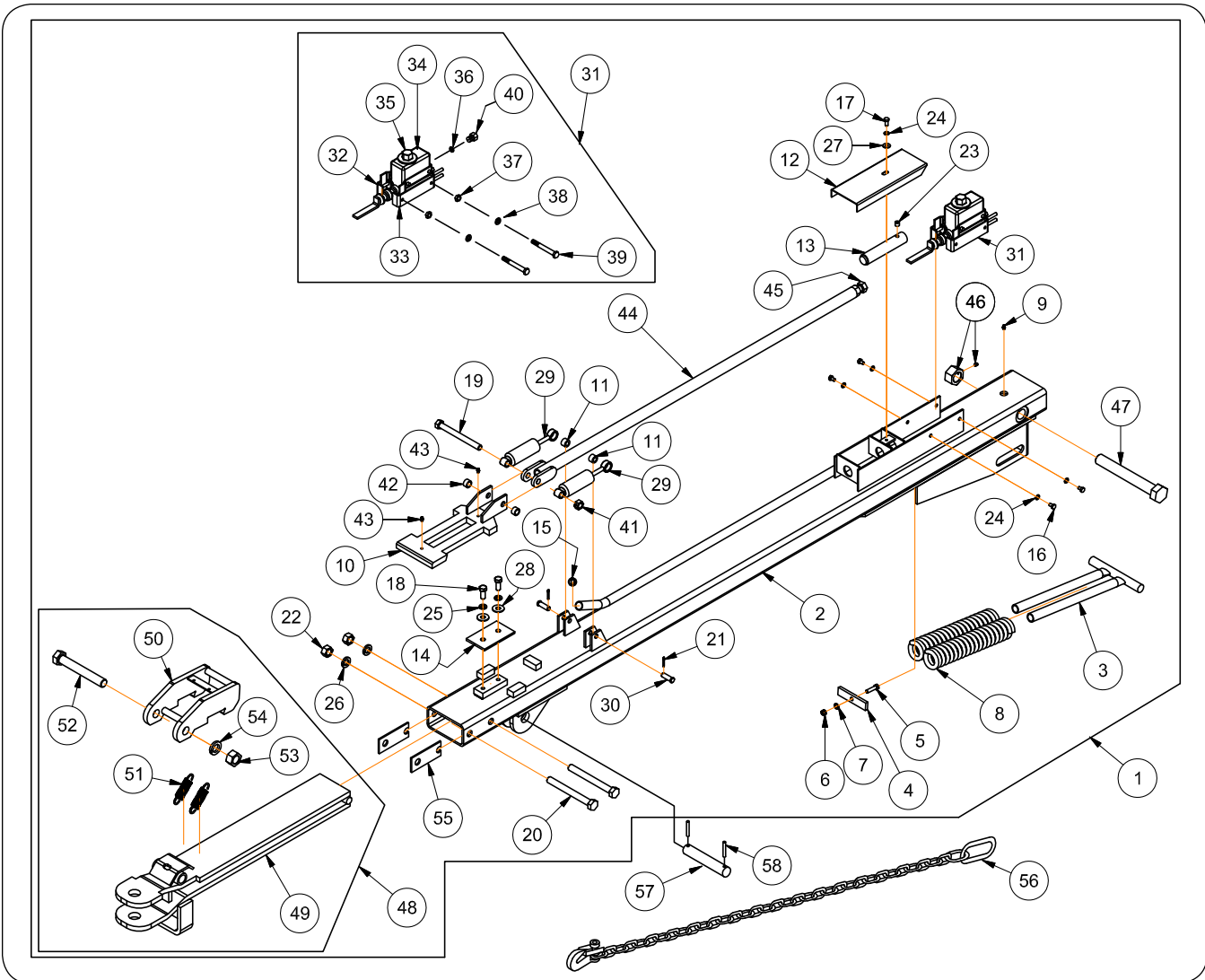

NOTE: The cap O-ring should be lubricated with brake fluid prior to hand tightening. Hand tighten ONLY!

ITEM	DESCRIPTION	PART NO.	QTY.	NOTES
1	Tongue Assembly =Green=	300097G	1	Includes Items 2 through 55
	Tongue Assembly =Red=	300097R		
2	Tongue Weldment =Green=	300993G	1	Includes Items 3 through 9
	Tongue Weldment =Red=	300993R		
3	Spring Guide Weldment	222189B	1	
4	Spring Retainer Plate	8-603027	1	
5	Capscrew, 3/8-16UNC x 1 1/2	9390-057	1	Grade 5
6	Hex Nut 3/8-16UNC	9394-006	1	
7	Lock Washer, 3/8	9404-021	1	
8	Compression Spring, 2 1/2" Dia.	9003880B	2	
9	Grease Zerk	91160	1	
10	Latch Plate Weldment	300032B	1	
11	Shock Bushing	300035	2	
12	Step Weldment =Black=	301207B	1	
13	Push Tube Weldment	300037B	1	

505 GRAIN WAGON — Parts

Tongue

ITEM	DESCRIPTION	PART NO.	QTY.	NOTES
14	Brace Bracket	300082B	1	
15	Grommet, Snap Bushing	9001815	1	
16	Capscrew, 5/16-18UNC x 1/2	9390-026	4	Grade 5
17	Capscrew, 5/16-18UNC x 3/4	9390-028	1	Grade 5
18	Capscrew, 1/2-13UNC x 1 1/4	9390-100	2	Grade 5
19	Capscrew, 5/8-11UNC x 6 1/2	9390-137	1	Grade 5
20	Capscrew, 3/4-10UNC x 7	9390-159	2	Grade 5
21	Cotter Pin, 1/8 Dia. x 1	9391-023	2	
22	Hex Nut, 3/4-10UNC	9394-016	2	
23	Setscrew, 1/2-13UNC x 1/2	9399-106	1	
24	Lock Washer, 5/16	9404-019	5	
25	Lock Washer, 1/2	9404-025	2	
26	Lock Washer, 3/4	9404-033	2	
27	Flat Washer, 5/16 USS	9405-070	1	
28	Flat Washer, 1/2 USS	9405-088	2	
29	Shock Absorber	91667	2	
30	Clevis Pin, 1/2 Dia. x 1 1/2	92966	2	
31	Master Cylinder w/Spring Bracket	92968	1	Includes Items 32 Through 40A
	Seal Kit for Master Cylinder	9001031	1	
32	Spring Bracket Right-Hand	91672	1	
33	Spring Bracket Left-Hand	91673	1	
34	Master Cylinder ONLY	9003931	1	
35	Fill Cap	92540	1	
36	Washer, Brass	91680	1	For Item #40 Only
37	Hex Nut 3/8-16UNC	9394-006	2	
38	Lock Washer, 3/8	9404-021	2	
39	Capscrew, 3/8-16UNC x 3	9390-063	2	Grade 5
40	Orifice Adapter	91679	1	Alternate
40A	Connector - Female Inverted Flare	9003774	1	Dryseal
41	Locknut, 5/8-11UNC	95905	1	
42	Spacer	9190	2	
43	Grease Zerk	91160	2	
44	Push Pipe Kit	300260	1	51 3/4" Tube Incl. Item #45
45	Capscrew, 3/4-10 x 2 Full Thread	95739	1	Factory Preset-Not Adjustable
46	Locknut, 1 1/4-7 UNC w/Setscrew	300189	1	
	Setscrew 5/16-18 UNC x 2	9002186	1	
47	Tongue Pivot Bolt 1 1/4-7 UNCx9 1/2	9001782	1	
48	Hitch Subassembly	300263	1	Includes Items 49 Through 54
49	Hitch Weldment	221092B	1	
50	Latch Assembly	300110B	1	
51	Extension Spring, 1 x 3 1/4	9002044	2	
52	Capscrew, 1-8 UNC x 7	9390-197	1	
53	Hex Nut, 1-8 UNC	9394-020	1	
54	Lock Washer, 1	9404-041	1	
55	Shim, Hitch	300081	2	
56	Transport Chain	95055	1	
57	Pin 1 1/4 Dia. x 3 3/4	250151	1	
58	Roll Pin, 5/16 Dia. x 2	9392-159	2	

Undercarriage Components

ITEM	DESCRIPTION	PART NO.	QTY	NOTES
1	Tie Rod Assembly Complete =GREEN=	300004G	2	Includes Items 2-6
	Tie Rod Assembly Complete =RED=	300004R		
2	Tie Rod Pipe Tube	8-402026	2	
3	Tie Rod Clamp	93668	4	
4	LH Threaded Tie Rod End w/Nut	92580	2	
5	RH Threaded Tie Rod End w/Nut	92581	2	
6	Cotter Pin 5/32" Dia. x 2	9391-037	4	
7	Turning Weldment =GREEN=	300015G	1	Includes Items #8-10
	Turning Weldment =RED=	300015R		
8	Capscrew 1/2-13UNC x 3	9390-107	2	Grade 5
9	Locknut 1/2-13UNC	94981	2	
10	Shaft/King Pin	8-603022	1	
11	Tongue Assembly =GREEN=	300097G	1	
	Tongue Assembly =RED=	300097R		
12	Tongue Pivot Nut 1 1/4-7UNC w/Set Screw	300189	1	Includes Item #13
13	Set Screw 5/16-18UNC	9002186	1	
14	Spindle Front Weldment LH =GREEN=	300268G	1	Includes Item #15
	Spindle Front Weldment LH =RED=	300268R		
15	Bronze Bushing 2 1/4" OD	92578	4	
16	Spindle Front Weldment RH =GREEN=	300269G	1	Includes Item #17
	Spindle Front Weldment RH =RED=	300269R		
17	Bronze Bushing 2 1/4" OD	92578	4	
18	Hub Sub Assembly	300454	2	Includes Items 19-33
19	Spindle 3 1/4" OD x 18 7/8	300438	2	
20	Hub Sub Assembly =GREEN=	300296G	4	Includes Items 21-23
	Hub Sub Assembly =RED=	300296R		
21	Drive-In Stud Bolt 3/4-16UNF x 2 3/4	9004943	32	
22	Bearing Cup #LM501310 2.891" OD	9349	4	
23	Bearing Cup #39412 4 1/8" OD	TA39412	4	
24	Inner Bearing Cone #39250	TA37827	4	
25	Bearing Cone #LM501349 1 5/8" ID	9247	4	
26	Brake Drum 13" (DICO)	92575	2	Serial Number B33500099 and Lower
	Brake Drum 13" (GVS)	9007018	2	Serial Number B33500100 and Higher
27	Capscrew 1/2-20UNF x 1	9390-323	16	Grade 5
28	Slotted Nut 1-14UNS	9393-020	4	Grade 2
29	Lock Washer 1/2"	9404-025	16	
30	Hub Cap	9442	4	
31	Spindle Washer 1"	9448	4	
32	Cotter Pin 1/4" Dia. x 2 1/2	9391-061	4	
33	Seal 3 1/8" ID #31414SA	9004501	4	
34	Axle Weldment =Green=	301128G	1	Includes Item #35
	Axle Weldment =Red=	301128R		
35	Bronze Bushing 2 1/4" OD	92578	2	
36	King Pin Assembly	300003	2	

(Continued)

Undercarriage Components

ITEM	DESCRIPTION	PART NO.	QTY	NOTES
37	Axle Weldment =Green=	301130G	1	
	Axle Weldment =Red=	301130R		
38	Reach Tube Weldment =Green=	301135G	1	
	Reach Tube Weldment =Red=	301135R		
39	Tongue Pivot Bolt 1 1/4-7UNC x 9	9001783	1	
40	Grease Zerk 1/4-28	91160	5	
41	Thrust Bearing	92583	2	
42	Brake Cluster RH	93669	1	Serial Number B33500099 and Lower Includes Items 43-45
	43 Hex Nut 1/2-20UNF	9394-009	4	Grade 5
	44 Lock Washer 1/2"	9404-025	4	
	45 Capscrew 1/2-20UNF x 1	9390-323	4	Grade 5
42A	Brake Cluster RH	9007016	1	Serial Number B33500100 and Higher Hardware (Items 43-45) not included
46	Brake Cluster LH	93670	1	Serial Number B33500099 and Lower Includes Items 47-49
	47 Lock Washer 1/2"	9404-025	4	
	48 Hex Nut 1/2-20UNF	9394-009	4	Grade 5
	49 Capscrew 1/2-20UNF x 1	9390-323	4	Grade 5
46A	Brake Cluster LH	9007017	1	Serial Number B33500100 and Higher Hardware (Items 47-49) not included
50	Capscrew 3/4-10UNC x 5	9390-155	2	Grade 5
51	Hex Nut 3/4-10UNC	9394-016	12	Grade 5
52	Hex Jam Nut 3/4-10UNC	9395-016	4	Grade 5
53	Capscrew 3/4-10UNC x 3 (Fully Threaded)	94733	10	Grade 5
54	Locknut 3/4-10UNC	96732	2	Grade 5
55	Torsion Bar Pin Weldment 1" Dia. x 6	220005	1	
56	Torsion Bar Pin Weldment 1" Dia. x 4 3/4	220151	1	
57	Hold Down Pin Weldment 1" Dia. x 2 15/16	220147	2	
58	Spring Pin 1" Dia. x 2 9/16	220249	1	
59	Spring Shaft Weldment	300083B	1	
60	Torsion Bar Weldment =Green=	300084G	1	
	Torsion Bar Weldment =Red=	300084R		
61	Spring Retainer Weldment =Black=	8-604051B	1	
62	Compression Spring	9001349B	1	
63	Hairpin Cotter .177" Dia. x 3.68	92424	2	
64	Cotter Pin 3/16" Dia. x 2	9391-046	4	
65	Hex Nut 1-8UNC (Grade 5)	9394-020	2	
66	Flat Washer 1"	9405-116	4	
67	Wheel Nut 3/4-16UNF	92458	32	Grade 8
68	Gasket Maker 3oz Tube	9003036	2	Not Shown

Wheels and Tires

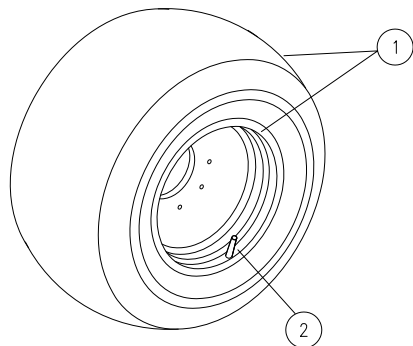

TIRES
 For questions regarding new tire warranty, please contact your local original equipment tire dealer. Used tires carry no warranty.

ITEM	DESCRIPTION	PART NO.	QTY.	NOTES
1	Wheel & Tire Assembly	17262	4	425/65R22.5 - Used
	Wheel & Tire Assembly	17263	4	445/65R22.5 - Used
1	Wheel & Tire Assembly	9004747/902563	4	460/65R22.5 - New
	Wheel Only	9004747	4	13 x 22.5; 8-Bolt
2	Valve Stem	93300	4	

Brake Components

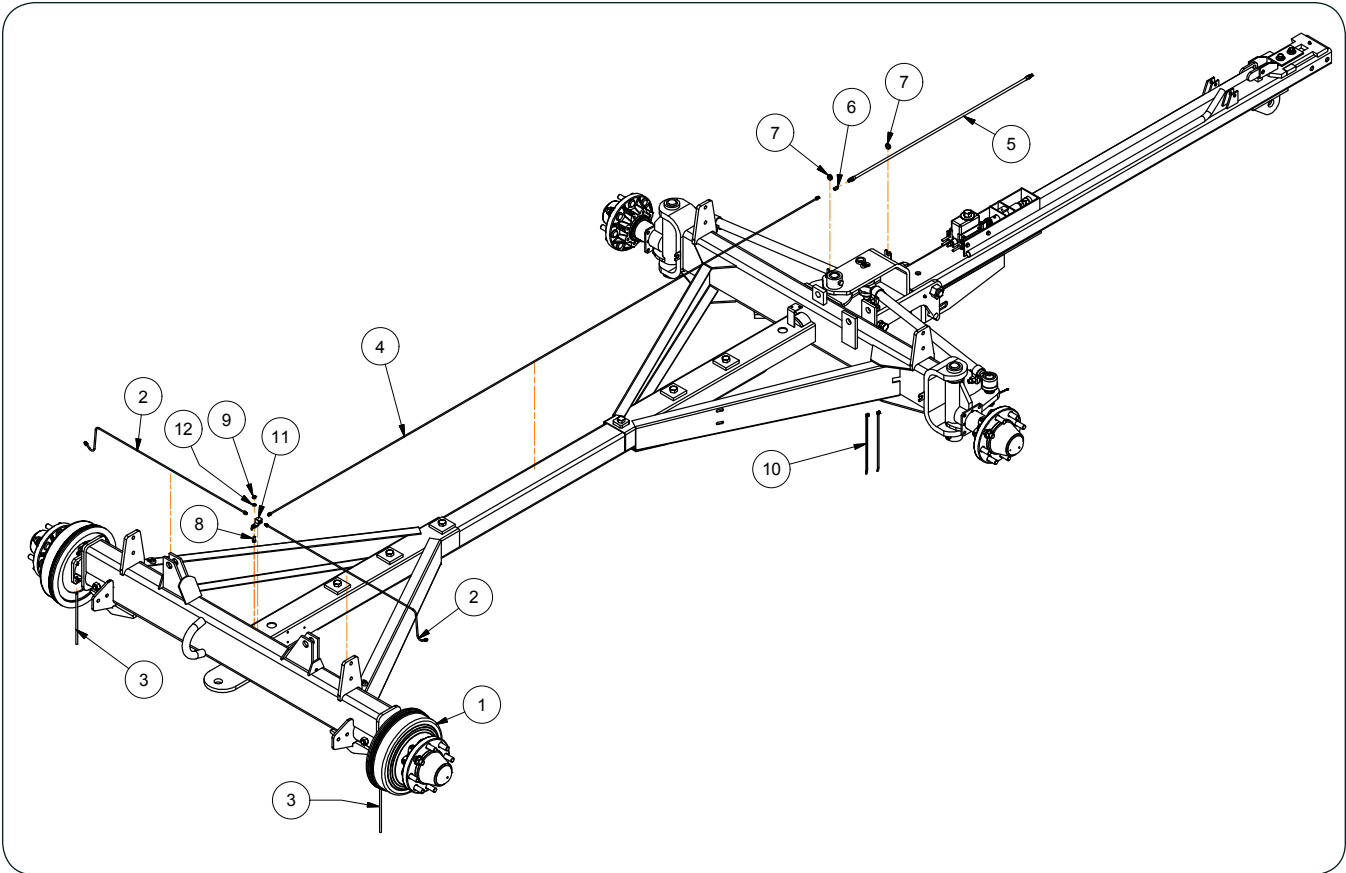

Brake Components

ITEM	DESCRIPTION	PART NO.	QTY.	NOTES
1	Brake Cluster	-	2	See 13" Brake Components for Parts
2	Brake Line, 41 1/2" Bundyweld	300471	2	
3	Bleeder Hose, 5/16 Dia. x 3/16 Dia. x 10	300480	2	
4	Bundyweld Tube, 3/16 Dia. x 126	9006914	1	
5	Brake Hose, 42"	9005636	1	
6	Union 3/8-24UNF-2B Inverted Flare Female	9005637	1	
7	Rubber Grommet 7/16" ID	9005653	2	
8	Capscrew, 5/16-18UNC x 3/4	9390-028	1	Grade 5
9	Hex Nut, 5/16-18UNC	9394-004	1	Grade 5
10	Cable Tie 11" Long	9003735	2	
11	Tee w/Mounting Bracket	9465	1	
12	Lock Washer 5/16"	9404-019	1	

NOTE: The cap O-ring should be lubricated with brake fluid prior to hand tightening. Hand tighten **ONLY!**

13" Brake Components — Beginning with Serial #B33980100

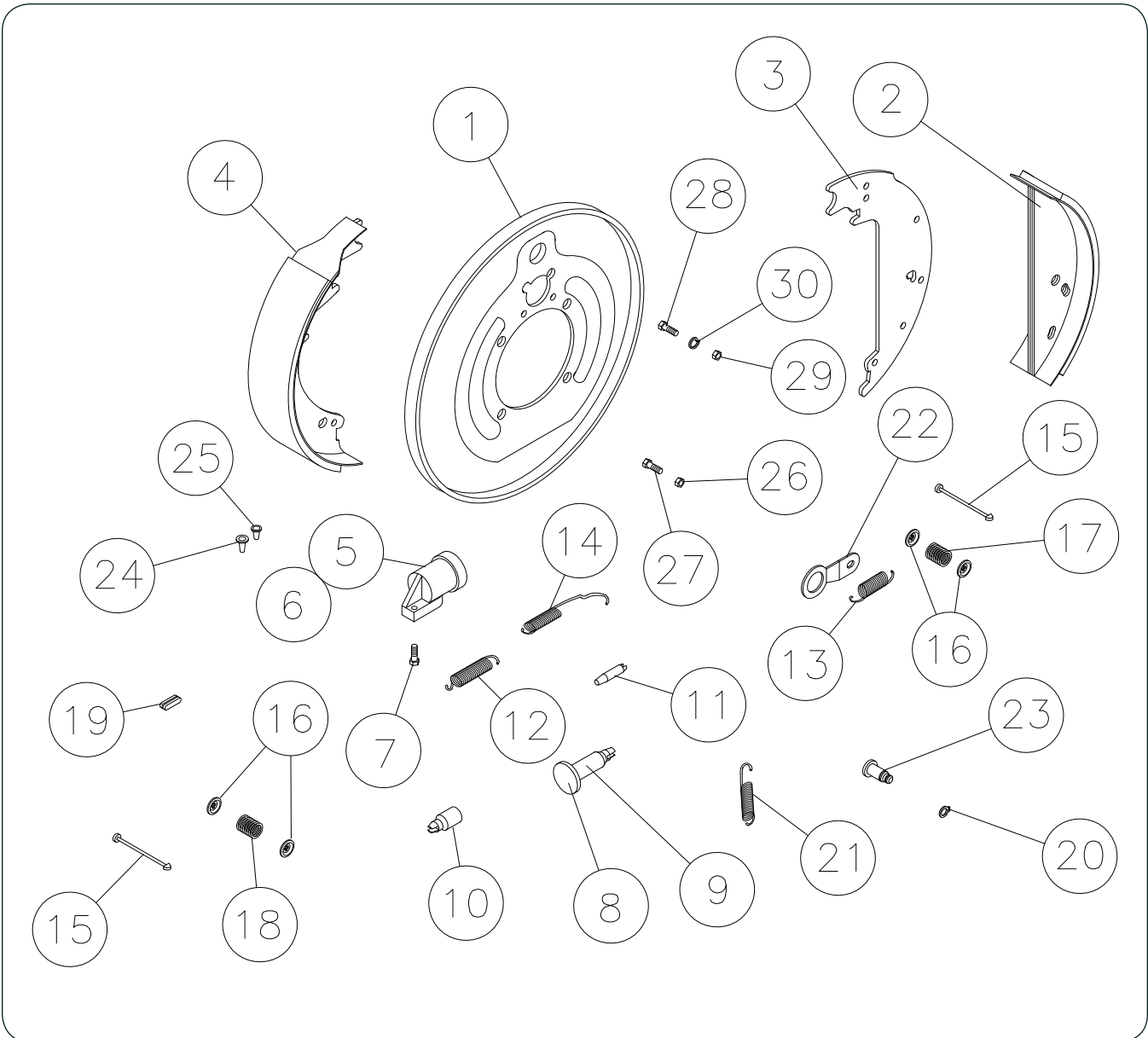

13” Brake Components — Beginning with Serial #B33980100

ITEM	DESCRIPTION	PART NO.	QTY.	NOTES
	RH Cluster Complete	9007016		
	LH Cluster Complete	9007017		
	Wheel Cylinder Repair Kit	9007045	1	
1	Back Plate Assembly	9007022	1	
2	Front Brake Shoe Assembly	9007023	1	
3	Front Shoe Lever	9007024	1	
4	Rear Brake Shoe Assembly	9007025	1	
5	Wheel Cylinder Assembly - Right	9007026	1	
6	Wheel Cylinder Assembly - Left	9007027	1	
7	Screw & Lock Washer	9007028	2	
8	Adjusting Pivot Nut	9007029	1	
9	Adjusting Screw	9007030	1	
10	Socket - Adjusting Screw	9007031	1	
11	Push Rod - Wheel Cylinder	9007032	1	
12	Spring - Adjusting Screw	9007033	1	
13	Spring - Front Lever	9007034	1	
14	Spring - Rear Shoe	9007035	1	
15	Pin - Shoe Hold Down	9007036	2	
16	Cup - Shoe Hold Down	9007037	4	
17	Spring - Front Hold Down	9007038	1	
18	Spring - Rear Hold Down	9007039	1	
19	Cover Plate - Adjusting Hole	9007040	1	
20	Nut	9007041	1	
21	Spring on F/B Lever	9007042	1	
22	Travel Link	9007043	1	
23	Bolt	9007044	1	
24	Plug, Plastic	91641	1	
25	Plug, Plastic	91645	1	
26	Locknut 5/16-18 UNC	93531	1	
27	Travel Link Bolt - Capscrew 5/16-18 UNC x 5/8	9390-027	1	
28	Capscrew, 1/2-20 UNF x 1	9390-323	4	
29	Hex Nut, 1/2-20 UNF	9394-009	4	
30	Lock Washer, 1/2	9404-025	4	

13" Brake Components — Prior to Serial #B33980100

ITEM	DESCRIPTION	PART NO.	QTY.	NOTES
	RH Cluster Complete	93669		
	LH Cluster Complete	93670		
	Wheel Cylinder Repair Kit	91646	1	
1	Back Plate Assembly	91609	1	
2	Front Brake Shoe Assembly	91610	1	
3	Front Shoe Lever	91611	1	
4	Rear Brake Shoe Assembly	91612	1	
5	Wheel Cylinder Assembly - Right	91613	1	
6	Wheel Cylinder Assembly - Left	91614	1	
7	Screw & Lock Washer	91615	2	
8 & 9	Adjusting Screw & Pivot Nut	91616	1	
10	Socket - Adjusting Screw	91618	1	
11	Push Rod - Wheel Cylinder	91619	1	
12	Spring - Adjusting Screw (yellow)	91620	1	
13	Spring - Front Lever (Red)	91621	1	
14	Spring - Rear Shoe (Orange)	91622	1	
15	Pin - Shoe Hold Down	91623	2	
16	Cup - Shoe Hold Down	91624	4	
17	Spring - Front Hold Down (Yellow)	91625	1	
18	Spring - Rear Hold Down (Black)	91626	1	
19	Cover Plate - Adjusting Hole	91627	1	
20	Retaining Ring (Truarc)	91628	1	
21	Locknut 5/16-18 UNC	93531	1	
22-27	Not Applicable	-	-	
28	Travel Link	91636	1	
29	Travel Link Bolt - Capscrew 5/16-18 UNC x 5/8	9390-027		
30	Pin - Front Shoe	91639	1	
31	Spring - Front Shoe	91640	1	
32	Not Applicable	-	-	
33	Hex Nut, 1/2-20 UNF	9394-009	4	
34	Capscrew, 1/2-20 UNF x 1	9390-323	4	
35	Lock Washer, 1/2	9404-025	4	
36	Stud - Brake Shoe Anchor	9004072	1	
36A	Lock Washer 3/4"	9004073	1	
	Lock Washer 3/4"	9404-033		
36B	Hex Nut 3/4-16UNF	9004074	1	Grade 5
	Hex Nut 3/4-16UNF	9394-015		

Gravity Box

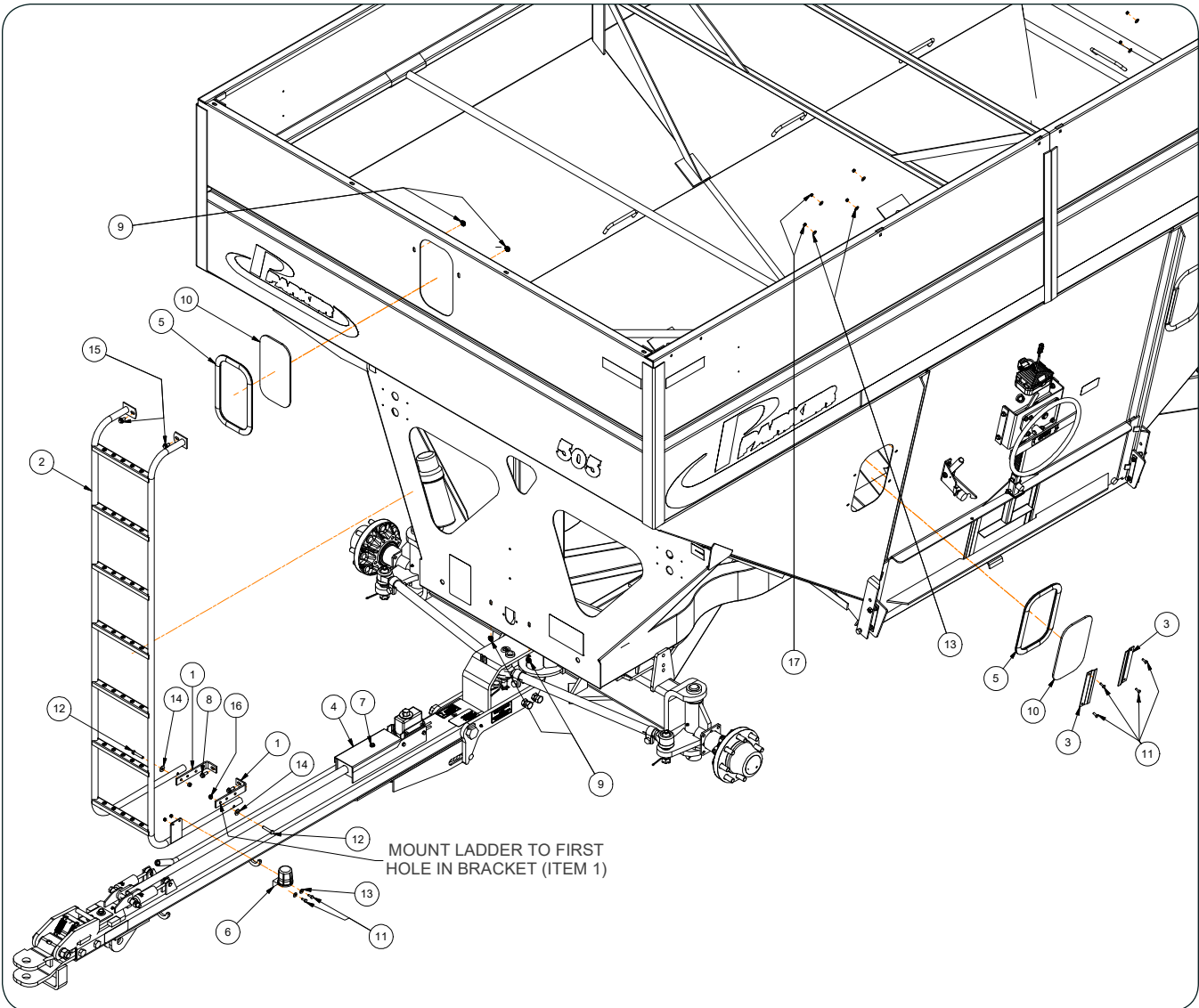

Gravity Box

ITEM	DESCRIPTION	PART NO.	QTY	NOTES
1	Bracket, Ladder =Black=	220288B	2	
2	Ladder =Black=	222013B	1	
3	Bracket, Window Retainer =Black=	250461B	4	
4	Brake Cover Weldment =Black=	301207B	1	
5	Window Molding	271951	4	
6	Trailer Connector Holder	9001968	1	
7	Flange Screw, 5/16-18UNC x 3/4 Gr.5	91256	1	
8	Flange Screw, 3/8-16UNC x 1 Gr.5	91262	2	
9	Flange Nut, 3/8-16UNC Gr.5	91263	6	
10	Window	92403	4	Kit 220512 - Includes Items 4, 6, 11, 12, 15, 20
11	Capscrew, 1/4-20UNC x 3/4 Gr.5	9390-003	10	
12	Capscrew, 3/8-16UNC x 2 Gr.5	9390-059	2	
13	Flat Washer, 1/4	9405-064	10	
14	Flat Washer, 3/8	9405-076	2	
15	Flange Screw, 3/8-16UNC x 3/4 Gr.5	95585	4	
16	Locknut, 3/8-16UNC Gr.5	9928	2	
17	Locknut, 1/4-20UNC Gr.5	9936	10	

Fender Components

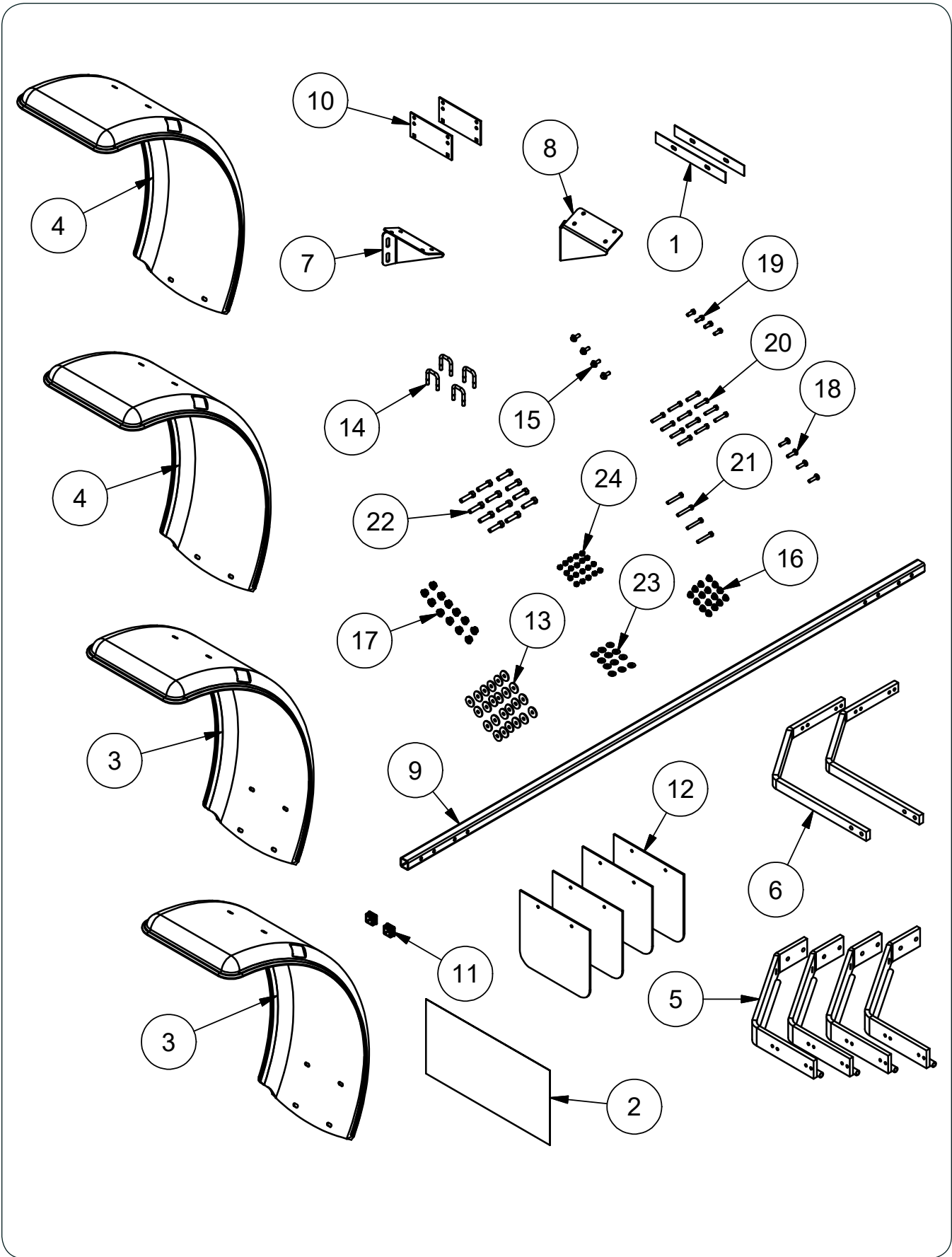

Fender Components

ITEM	DESCRIPTION	PART NO.	QTY	NOTES
	Standard Tire Fender Kit =Black=	301086B	1	
1	Back Fender Plate =Black=	220725B	2	
2	Film, Paint Protection	220890	1	
3	Front Fender	221259	2	
4	Rear Fender	221260	2	
5	Fender Plate Weldment =Black=	300618B	4	
6	Fender Bar Mount =Black=	300620B	2	
7	Fender Bracket, Right-Hand =Black=	300644B	1	
8	Fender Bracket, Left-Hand =Black=	300645B	1	
9	Fender Tube Mount =Black=	300671B	1	
10	Fender Plate Mount =Black=	300672B	2	
11	Plastic Square Plug	9001645	2	
12	Rubber Mud Flap	9001691	4	
13	Fender Washer, 3/8	9005696	24	
14	U-Bolt, 3/8-16UNC x 2.25	91163	4	
15	Flange Screw, 3/8-16UNC x 1 Gr.5	91262	4	
16	Large Flange Nut, 3/8-16UNC Gr.5	91263	16	
17	Flange Nut, 1/2-13UNC	91267	12	
18	Carriage Bolt, 3/8-16UNC x 1 1/2 Gr.5	9388-053	4	
19	Capscrew, 3/8-16UNC x 1 Gr.5	9390-055	4	
20	Capscrew, 3/8-16UNC x 2 Gr.5	9390-059	12	
21	Capscrew, 3/8-16UNC x 2 1/2 Gr.5	9390-061	4	
22	Capscrew, 1/2-13UNC x 1 3/4 Gr.5	9390-102	12	
23	Flat Washer, 3/8	9405-076	12	
24	Lock Nut, 3/8-16UNC Gr.5	9928	20	

Fender Light Components

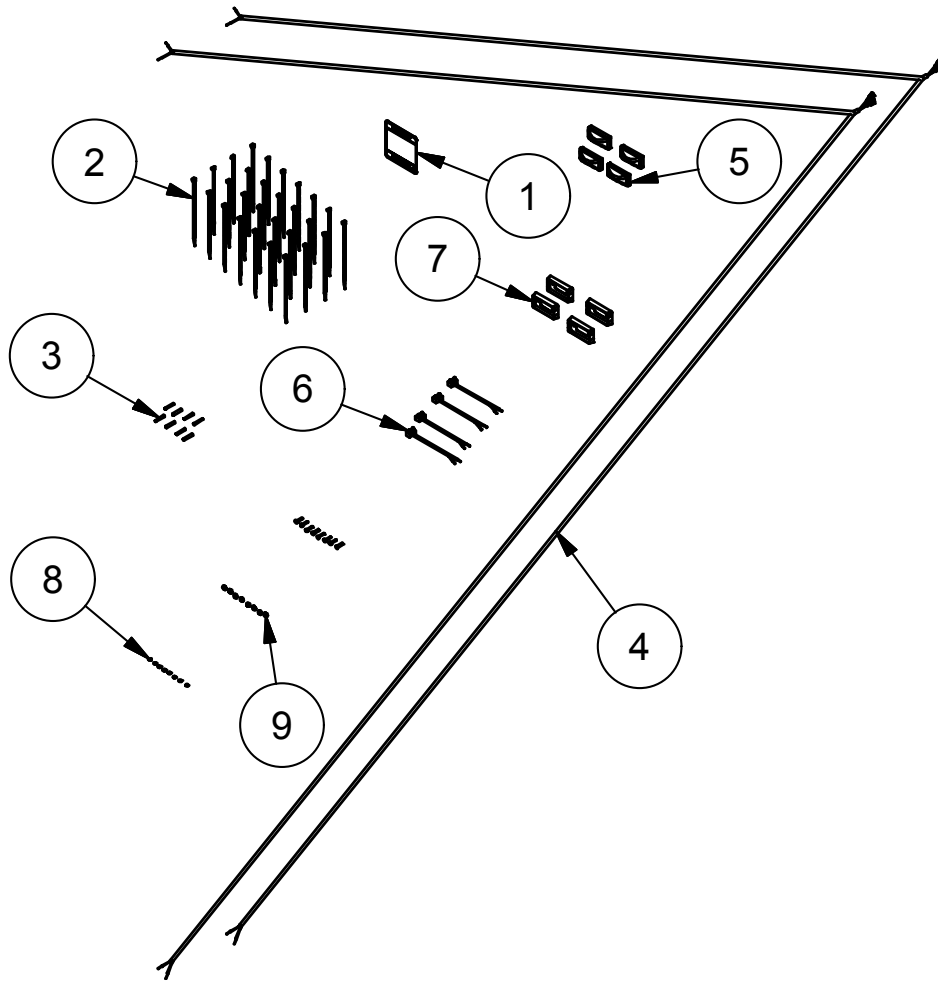

Fender Light Components

ITEM	DESCRIPTION	PART NO.	QTY	NOTES
1	Decal, Important Instructions	251027	1	
2	Cable Tie, 6" Long	9000106	28	
3	Butt Connector, 14-16 GA.	9000166	8	
4	Fender Light Harness	9006184	2	
5	Amber LED Light	9006333	4	
6	Pigtail Harness	9006334	4	
7	Bezel Light Mount	9006335	4	
8	Split Lock Washer, #8(.164)	9404-011	8	
9	Hex Nut, #8-32UNC Gr.2	9830-015	8	

Door Wheel with Gear Reduction

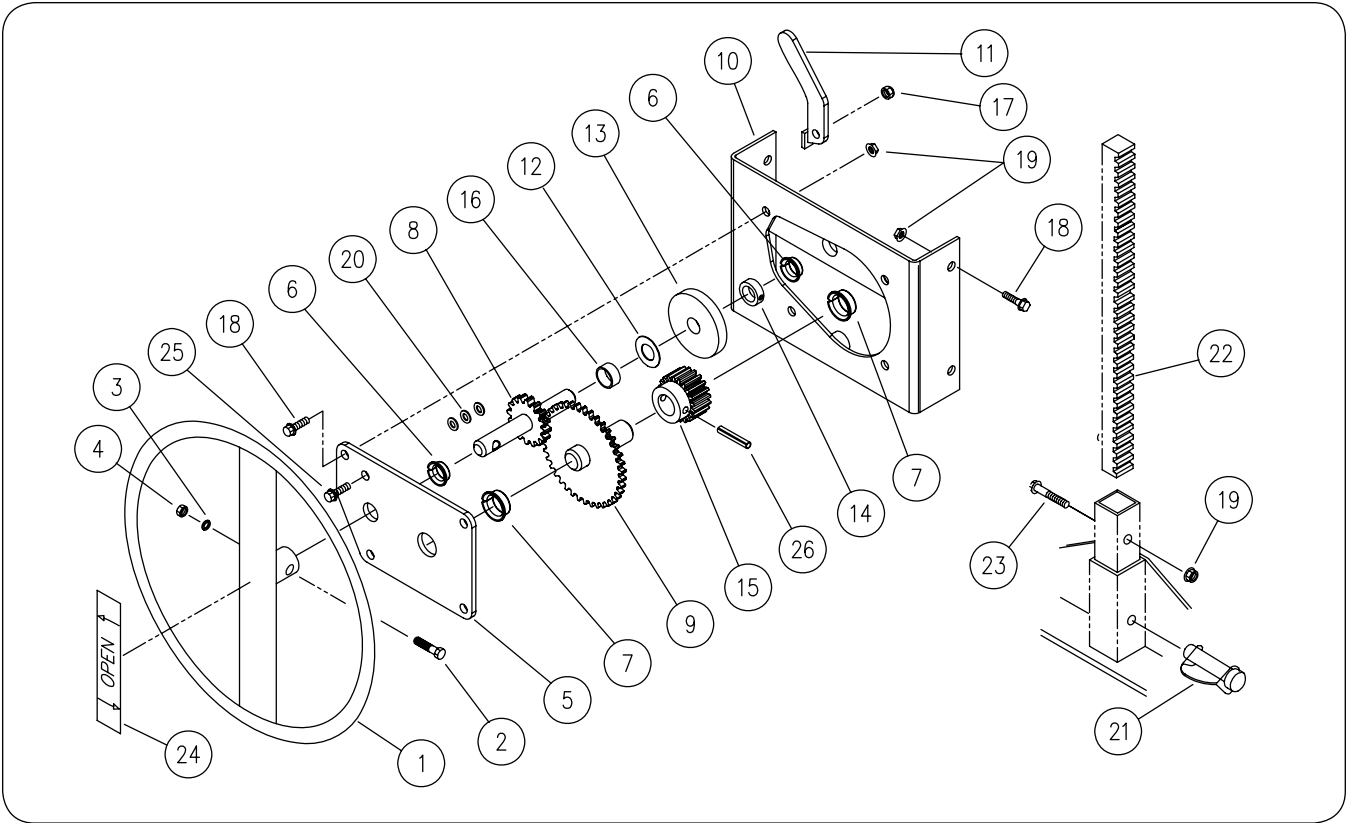

Door Wheel with Gear Reduction

ITEM	DESCRIPTION	PART NO.	QTY	NOTES
	Door Wheel w/Gear Reduction	222059	1	Incl. Items 1-20, 25, 26
1	Door Wheel Assembly	220060B	1	
2	Capscrew, 3/8-16 UNC x 2	9390-059	1	
3	Lock Washer, 3/8	9404-021	1	
4	Hex Nut, 3/8-16 UNC	9394-006	1	
5	Plate	222062B	1	
6	Flanged Split Bushing	9003411	2	3/4 x 1 1/8 x 3/8
7	Flanged Split Bushing	9003412	2	1 x 1 3/8 x 1/2
8	Input Shaft / Gear	222071	1	
9	Output Shaft / Gear	222072	1	
10	Cover Plate Weldment	222057B	1	
11	Lock Weldment	222068B	1	
12	Flat Washer, 3/4 SAE	9405-104	1	
13	Plastic Roller	9001879	1	
14	Locking Collar, 3/4"	9001868	1	
15	Spur Gear - 20 Tooth	9003442	1	
16	Bushing	222073	1	1 x 3/4 x 1/2
17	Locknut, 3/8-16 UNC	9003396	1	
18	Flange Screw, 3/8-16 UNC x 1	91262	9	
19	Flange Nut, 3/8-16 UNC	91263	9	
20	Flat Washer, 3/8	9405-076	3	
21	Lynch Pin, 3/8 x 2 1/4	9000938	1	
22	Gear Door Rack	220033B	1	
23	Capscrew, 3/8-16 UNC x 2	9390-059	1	
24	Decal, OPEN	9001898	1	
25	Serrated Flange Screw, 3/8-16 x 1 1/4	9003259	1	Full Threaded
26	Roll Pin, 5/16 Dia. x 1 3/4	9392-157	1	

Kick Back Chute and SMV Components

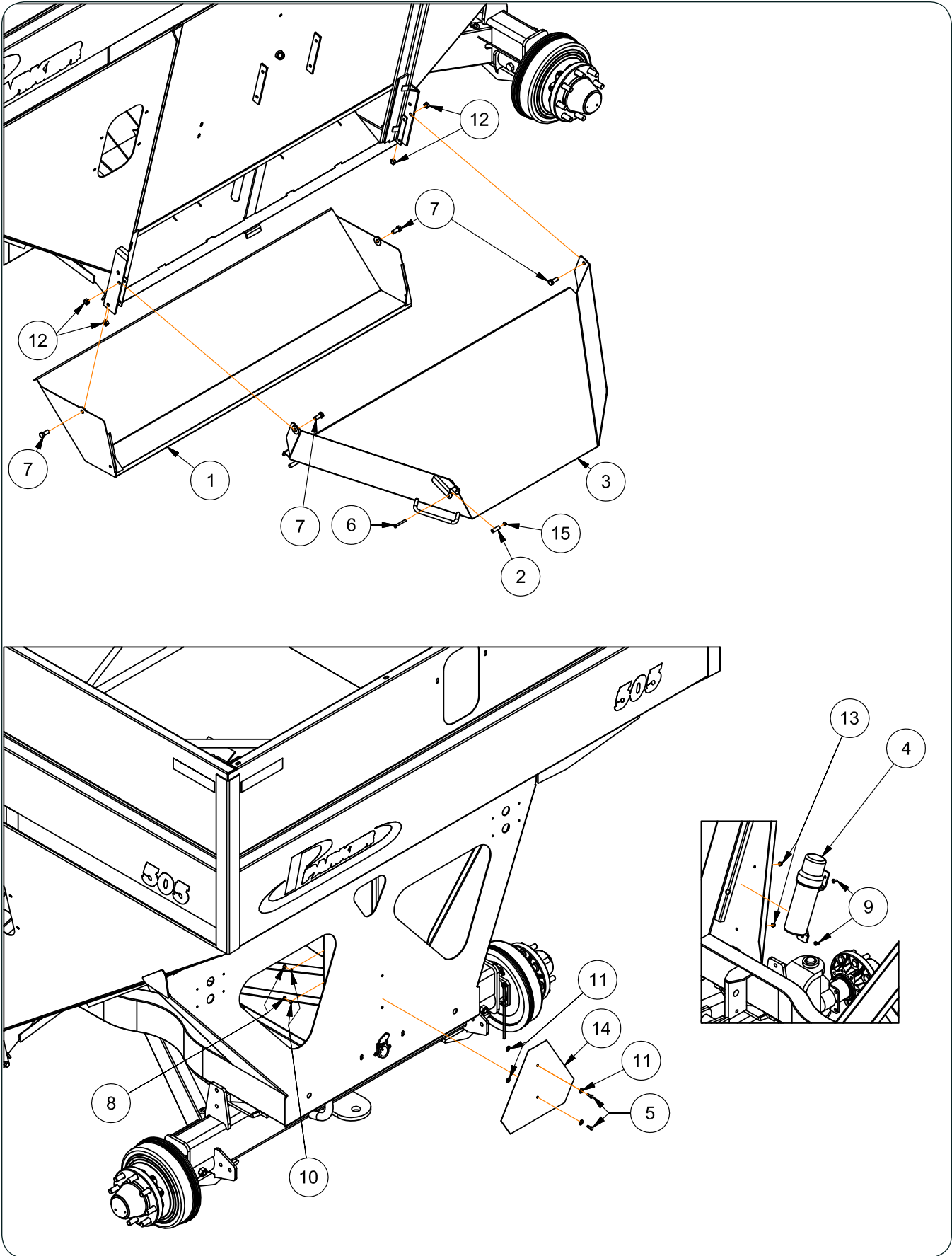

Kick Back Chute and SMV Components

ITEM	DESCRIPTION	PART NO.	QTY	NOTES
1	Kick Back Chute Weldment =Black=	222180B	1	
2	Latch Bushing	301081	1	
3	Chute Weldment =Black=	301082B	1	
4	Manual Holder	900552	1	
5	Capscrew, 1/4-20UNC x 3/4 Gr.5	9390-003	4	
6	Capscrew, 1/4-20UNC x 2 1/4 Gr.5	9390-010	1	
7	Capscrew, 1/2-13UNC x 1 1/4 Gr.5	9390-100	4	
8	Hex Nut, 1/4-20UNC Gr.5	9394-002	2	
9	Phillips Head Machine Screw, 1/4-20UNC x 3/4	903174-535	2	
10	Lock Washer, 1/4	9404-017	2	
11	Flat Washer, 1/4	9405-064	6	
12	Center Locknut, 1/2-13UNC	94981	4	
13	Large Flange Hex Nut, 1/4-20UNC Gr.5	97189	2	
14	SMV Emblem	9829	1	
15	Locknut, 1/4-20UNC Gr.5	9936	3	

Chute and Latch Components

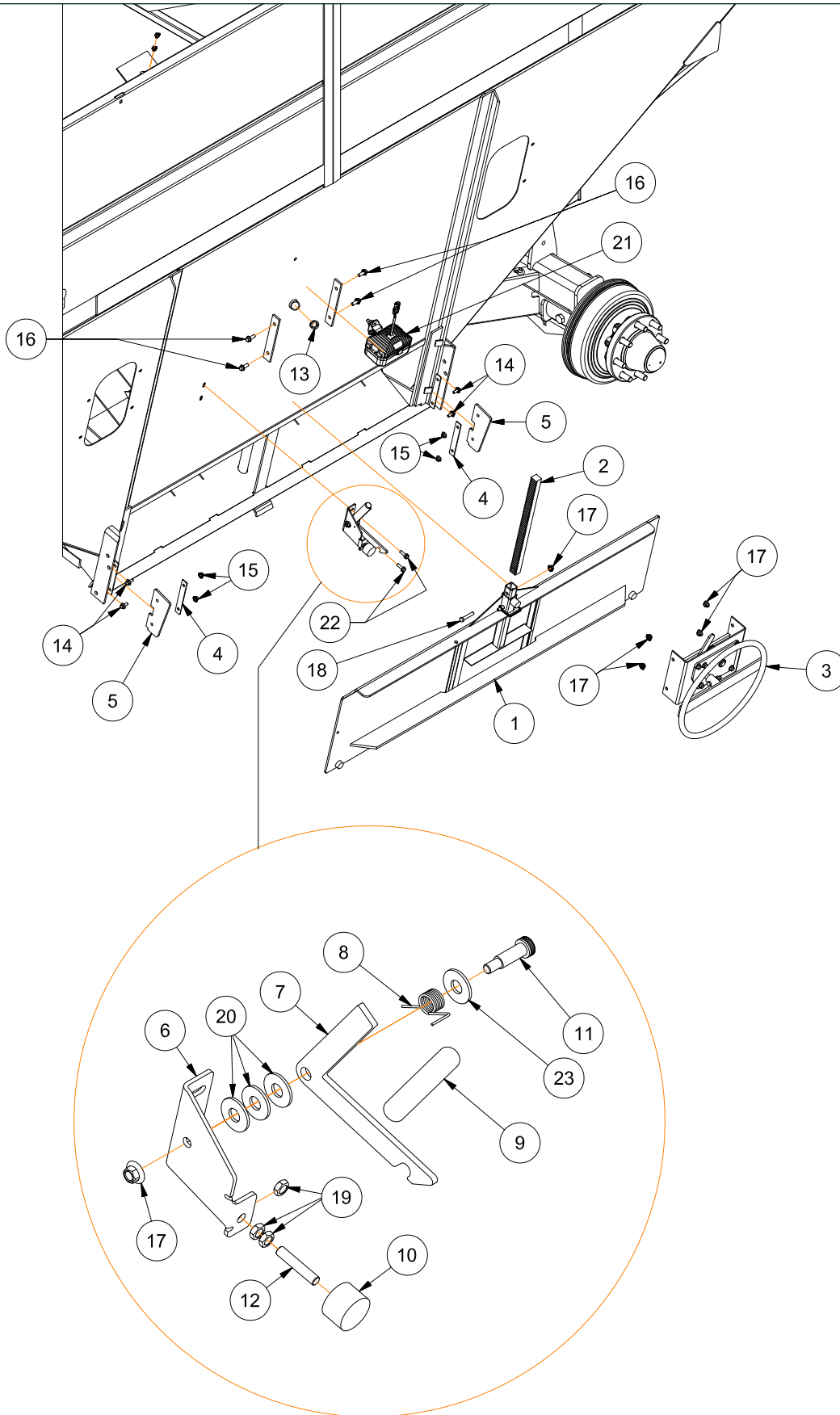

Chute and Latch Components

ITEM	DESCRIPTION	PART NO.	QTY	NOTES
1	Door Weldment =Black=	220020B	1	
2	Door Rack Bar =Black=	220033B	1	
3	Door Lift Assembly	222059	1	Refer to “Door Wheel with Gear Reduction” in this Section for Parts
4	Deflector Plate =Black=	273687B	2	
5	Deflector	301035	2	
6	Latch Bracket =Black=	301077B	1	
7	Latch Arm Plate =Black=	301079B	1	
8	Torsion Spring	9003053	1	
9	Handle Grip	9006337	1	
10	Rubber Bumper	9006745	1	
11	Shoulder Bolt, 1/2 x 1 1/4	9006746	1	
12	Rod	9006747	1	
13	Snap Bushing, 1”	9006826	1	
14	Flange Screw, 5/16-18UNC x 3/4 Gr.5	91256	4	
15	Large Flange Hex Nut, 5/16-18UNC Gr.5	91257	6	
16	Large Flange Hex Screw, 3/8-16UNC x 1 Gr.5	91262	4	
17	Large Flange Nut, 3/8-16UNC Gr.5	91263	6	
18	Capscrew, 3/8-16UNC x 2 Gr.5	9390-059	1	
19	Hex Jam Nut, 3/8-16UNC Gr.5	9395-006	3	
20	Flat Washer, 1/2 SAE	9405-086	3	
21	Work Light w/Switch	9500801	1	
22	Large Flange Hex Screw, 5/16-18UNC x 1 Gr.5	97604	2	
23	Flat Washer, 1/2 USS	9405-088	1	

Decals

ITEM	DESCRIPTION	PART NO.	QTY	NOTES
1	Decal, Door Open	9001898	1	
2	Decal, Tongue Pivot	9002187	1	
3	Reflector, Red	9003126	2	
4	Reflector, Amber	9003127	5	
5	Decal, Warning No Riders	9003476	1	
6	Decal, Parker Logo	9004172	2	
7	Decal, Parker Left Swoosh	9004174	2	
8	Decal, Parker Stripe	9004175	7	
9	Decal, 505	9004182	4	
10	Decal, Parker Logo	9004377	2	
11	Decal, Tire Pressure	9006724	1	
12	Decal, FEMA	91605	1	
13	Decal, DANGER "Just for Kids"	97603	1	
14	Decal, WARNING "High-Pressure Fluid"	95445	1	
15	Decal, CAUTION "Transport Chain"	97575	1	
16	Decal, WARNING "Read and Understand"	97961	1	
17	SMV Emblem	9829	1	
18	Decal UM Wheel Systems	94754	1	
19	Decal, CAUTION (Slippery Surface)	95008	2	
20	Decal, Prefilled Tie Rod Grease	9008321	1	
21	Decal, Rear SIS 20 MPH	9008714	2	
22	Decal, Rear SIS 20 KPH	9008720	2	

Touch-Up Paint

PAINT	SPRAY
Black	97013
Green	97015
Red	97301
Primer, Gray	9500166

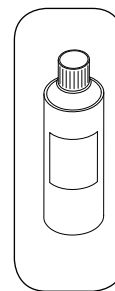

Electrical Components

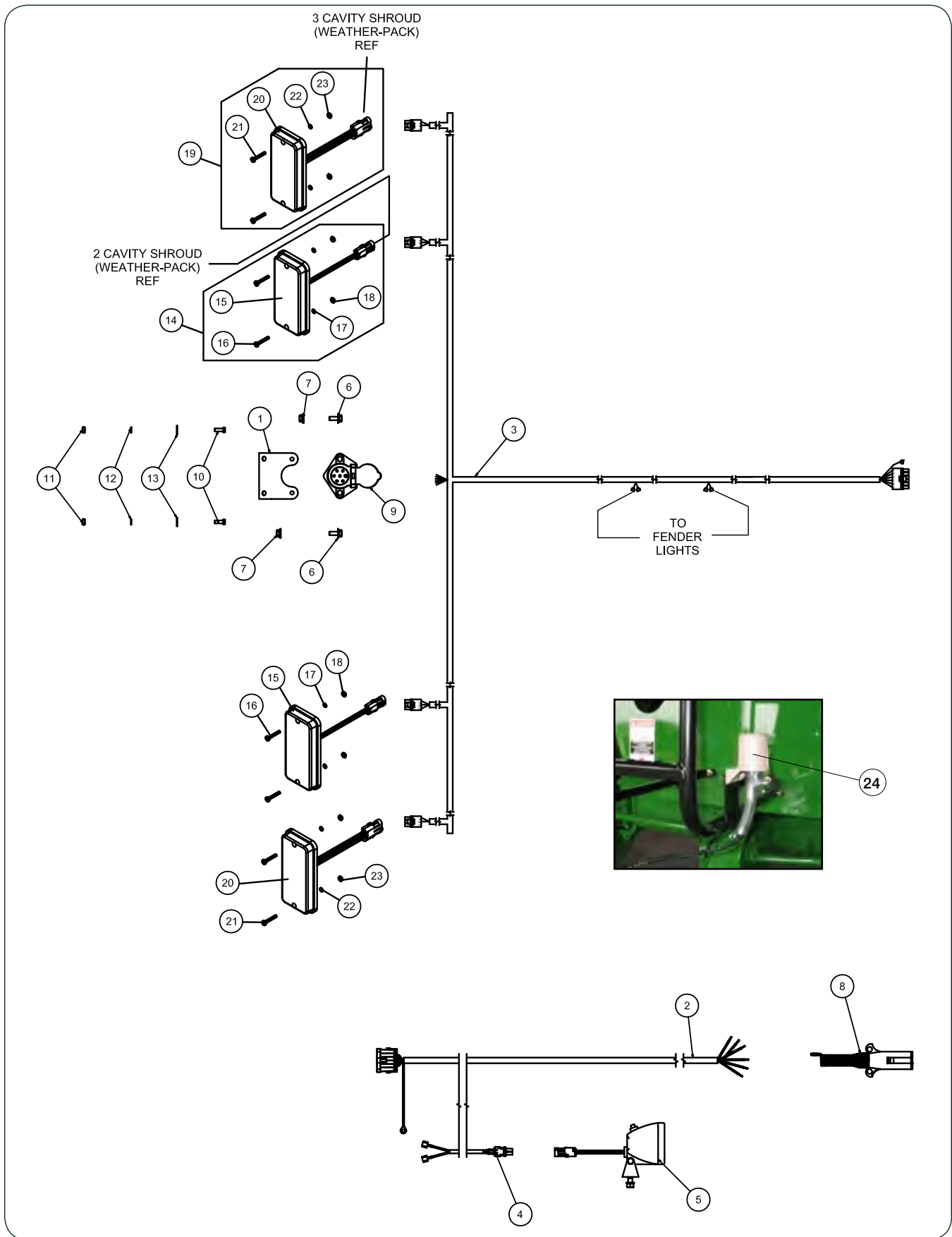

Electrical Components

ITEM	DESCRIPTION	PART NO.	QTY.	NOTES
1	Bracket - Socket	221527B	1	
2	Wire Harness 218"	9006066	1	
3	Harness - Rear, Wagon	9006699	1	
4	Harness - Chute	9006330	1	
5	Light Assembly	9500801	1	
6	Large Flange Screw, 5/16-18UNC x 3/4 Gr.5	91256	2	
7	Large Flange Nut, 5/16-18UNC Gr.5	91257	2	
8	7-Way Plug	92450	1	
9	Socket 7-Way w/ Split Pins	92824	1	
10	Capscrew, 1/4-20UNC x 3/4 Gr.5	9390-003	2	
11	Hex Nut, 1/4-20UNC Gr.5	9394-002	2	
12	Lock Washer, 1/4	9404-017	2	
13	Flat Washer, 1/4 USS	9405-064	2	
14	LED Light Conversion Kit (Amber)	232168	1	
15	Tail Light, LED Amber (2-Cavity Shroud)	9006281	1	
16	Pan Head Machine Screw, #10-32UNF x 1 1/4	903172-350	2	
17	Lockwasher, #10	9404-013	2	
18	Nut, #10-32UNF	9830-016	2	
19	LED Light Conversion Kit (Red)	232170	1	
20	Tail Light, LED Red (3-Cavity Shroud)	9006282	1	
21	Pan Head Machine Screw, #10-32UNF x 1 1/4	903172-350	2	
22	Lockwasher, #10	9404-013	2	
23	Nut, #10-32UNF	9830-016	2	
24	Connector Holder	9001968	1	

Weather Guard Tarp Components - Optional

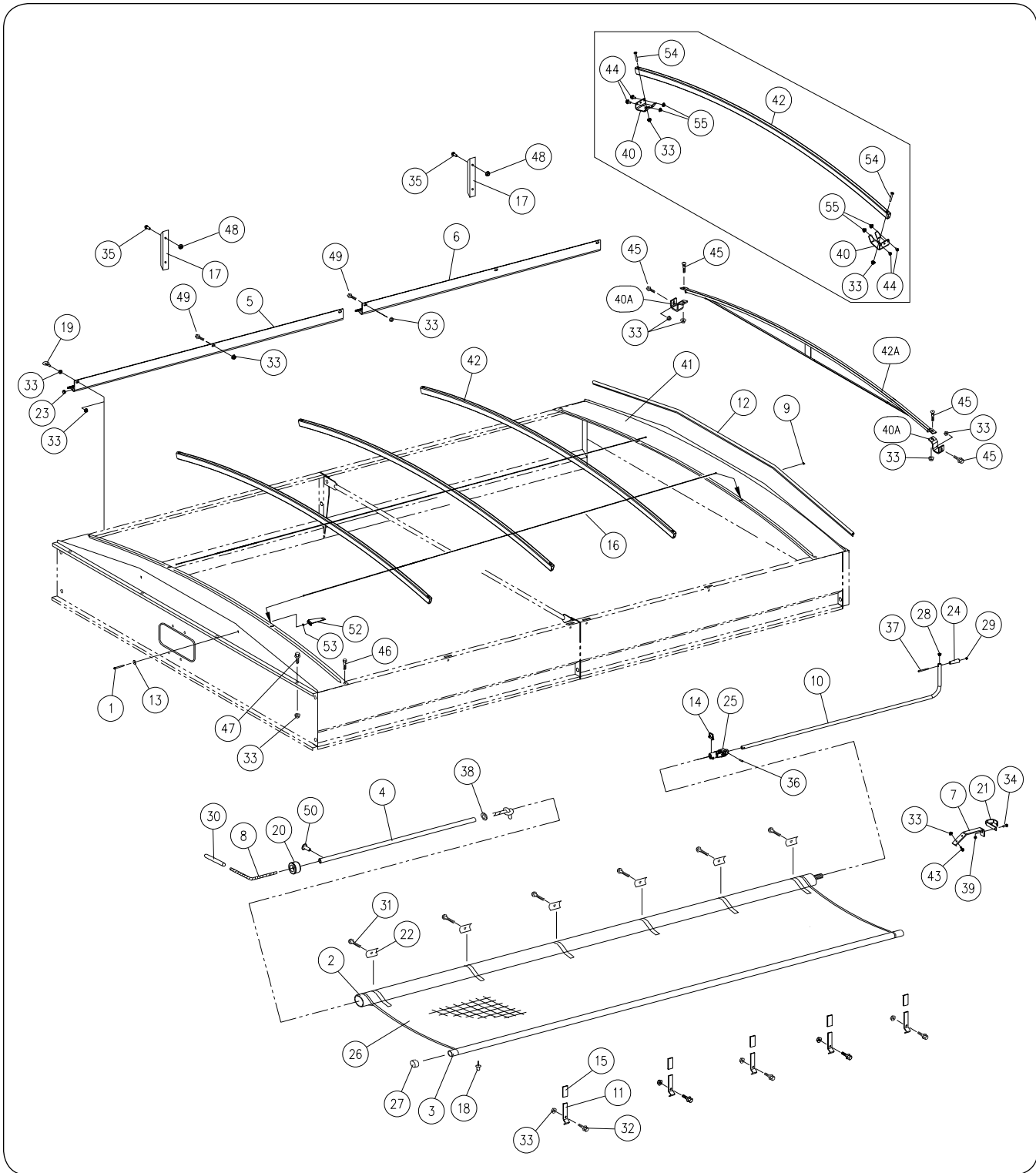

ITEM	DESCRIPTION	PART NO.	QTY	NOTES
	Tarp Kit w/End Caps	221637	-	
1	Capscrew, 3/8-16UNC x 4 1/2	TA0-907131-0	4	Grade 5
2	Roll Tube Weldment	221577	1	
3	Fixed Tube Weldment	221580	1	
4	Pipe - 132"	221582	1	

Weather Guard Tarp Components - Optional

ITEM	DESCRIPTION	PART NO.	QTY	NOTES
5	Plate - Latch 90" (Front)	221780	1	
6	Plate - Latch 90" (Rear)	221781	1	
7	Tube Crank Holder Weldment	220579B	1	
8	Bungee Cord 3/8" Dia. x 156"	221721	1	
9	Plug, 7/16	9005727	3	
10	Tarp Handle Weldment	221748	1	
11	Tarp Short Stop Plate	266689B	5	
12	Trim-lok	9000787	A/R	
13	Fender Washer, 3/8"	9005696	4	
14	Lynch Pin 3/8" x 3"	9005305	1	
15	Cap - Plastic (2 x 3)	9003078	5	
16	Cable Assembly, 163"	9005708	3	
17	Deflector	9005307	2	
18	Rivet/Pop 3/16"	9003378	2	
19	Eye Bolt 3/8-16UNC x 1 3/4	9004548	1	
20	Plug 2"	9004947	1	
21	Handle Retainer (Metal)	221770B	1	
22	U-Clamp	9004949	6	
23	Plug 1"	9004968	2	
24	Handle	9004969	1	
25	U-Joint w/ 1 3/8-21 Spline	9004977	1	
26	Tarp 130 x 174	9004955	1	
	Tarp Repair Kit	9005581	-	
27	Plug 1 1/8	9005088	2	
28	Plug 1 1/4	9005089	1	
29	Elastic Stop Nut 3/8-16UNC	9398-012	1	
30	Hose 1/2 EPDM	TA806225	1	
31	Screw/Self Drilling #10-16 x 3/4 Pan Head	9005197	6	
32	Screw/Large Flange 3/8-16UNC x 1	91262	5	Grade 5
33	Nut/Large Flange 3/8-16UNC	91263	29	Grade 5
34	Capscrew 3/8-16UNC x 1	9390-055	1	Grade 5
35	Screw 1/4-20UNC x 1 (Self-Threading)	9004355	4	
36	Roll Pin 3/8" Dia. x 2"	9392-180	1	
37	Pan Head 3/8-16UNC x 4 1/2 Phillips Machine Screw	903172-450	1	
38	Flat Washer 3/8	9405-074	1	
39	Locknut 3/8-16UNC	9928	1	
40	Bracket For Side Boards/Tarp Bow Weldment =Black=	283425B	6	For SN B37690100 & Higher
40A		300977B		For SN B37690099 & Lower
41	End Cap Weldment (Front & Rear)	300494B	2	
42	Tarp Bow Weldment =Black=	301208B	3	For SN B37690100 & Higher
42A	Tarp Bow Weldment =Black= Service Replacement Kit	301210B		For SN B37690099 & Lower
43	Capscrew 3/8-16UNC x 1 (Self-Tapping)	96972	2	Grade 5
44	Large Flange Screw 5/16"-18UNC x 3/4"	91256	12	For SN B37690100 & Higher
45	Carriage Bolt 3/8-16UNC x 1	9388-051	8	Grade 5
46	Screw/Self Drilling 1/4-14 x 1 Hex Washer Head	9512	4	
47	Capscrew/Large Flange 3/8-16UNC x 3/4	95585	8	Grade 5
48	Hex Nut/Large Flange 1/4-20UNC	97189	4	
49	Truss Screw 3/8-16UNC x 1 Torx Head Machine Screw	9005312	4	Grade 5
50	Self Drilling Screw #10-16 x 1/2	9001396	1	
51	Tarp Repair Kit	9005581	1	Not Shown
52	Bracket & U-Nut Assembly	281712B	3	
53	Lock Washer, 3/8" External Tooth	9005688	4	
54	Countersunk Capscrew 3/8"-16UNC x 3"	902703-046	6	For SN B37690100 & Higher
55	Large Flange 5/16"-18UNC	91257	12	



Unverferth[®]
Manufacturing Company, Inc.

www.unverferth.com