



PREMIER T-TANK SPRAYERS
MODELS TA1200, TA1600, & TA2400

Serial Number B46520100 & Higher

Part No. 417902

Foreword



This symbol identifies important safety messages. When you see it, read the message that follows and be alert to the possibility of personal injury.

Remember, safety instructions stated in this manual are for your protection. Read them carefully and follow them closely when working around or using this machine.

Read and study this manual completely before attempting to operate this implement. Take this manual to the field for handy reference when operating, adjusting, or servicing your machine.

When referenced, “Right-Hand” (RH) and “Left-Hand” (LH) side of the machine are determined by standing behind the machine and facing in the direction of travel.



Product Information

When ordering parts or when requesting further information or assistance, always give the following information:

- Machine name
- Model number
- Serial number

All products manufactured by Unverferth Mfg. Co., Inc. are warranted to be free from material and workmanship defects for one full year from time of consumer delivery. Your local dealer will gladly assist you with any warranty questions.

Please fill out and retain this portion for your records.

Purchase Date _____ Model _____ Serial No. _____

Dealer _____ City _____

Dealer Contact _____ Phone _____



IMPORTANT

- *The information, specifications, and illustrations in the manual are based on information available at the time it was written. Due to continuing improvements in the design and manufacture of Unverferth products, all specifications and information contained herein are subject to change without notice.*

Table of Contents

Section I
Safety

General Hazard Information	1-2
Safety Decals	1-3
Following Safety Instructions	1-4
Before Servicing or Operating	1-5
During Operation	1-6
Before Transporting	1-6
During Transport	1-6
Pressurized Oil	1-7
Chemical Hazards	1-8
Access and Egress	1-8
Clean Water Tank	1-9
Preparing for Emergencies	1-10
Wearing Protective Equipment	1-10

Table of Contents

Section II
Set Up

Pre-Delivery Checklist 2-2

Dealer Set Up 2-3

 Remove Shipping Axle Capscrews 2-3

 Installing Drain Plug 2-4

 Rotate Wing Hose Brackets (120' & 132' Boom Only) 2-4

 Boom Rest Brackets For Model TA1600 Only 2-5

Tongue Adjustment 2-6

 Units With Fixed Position Hitch 2-6

 Units With Steerable Hitch 2-6

Axle Tread Setting 2-7

 Wheel Spacing Combinations 2-7

 Adjustment 2-9

 Tracks Toe In Adjustment 2-12

Equalizer® Track System 2-14

Installing Boom Control Box 2-14

Installing Rate Controller 2-14

Boom Functions 2-15

 Setting Flow 2-15

Rate Control Module (RCM) Set Up 2-16

Flow Meter Calibration 2-23

 Catch Test Calibration 2-23

 Applied Product Calibration 2-25

 Nozzle Flow Check 2-27

Control Box 2-30

Command Center 4 System Set Up 2-31

 Procedure For Linking Radio And Receiver 2-31

Hydraulic Manifold Set Up 2-32

 Set Up For Power Beyond Connection 2-32

 Closed-Center Conversion Kit 2-33

Setting the Pump Pressure - PWM 2-34

Setting the Pump Pressure - Non-PWM 2-35

Sprayer Calibration 2-36

 Determine Required Nozzle Size 2-36

Electric Command Center Installation 2-37

XRT Autoboom Height Control 2-40

Steerable Hitch 2-40

Table of Contents

**Section III
Operation**

Operating Checklist.....	3-2
Preparing Tractor.....	3-3
Preparing Sprayer.....	3-3
Hitching to Tractor.....	3-5
Drawbar Hitching.....	3-5
Jack Usage.....	3-6
Transport Chain.....	3-7
Hydraulic Connections.....	3-8
Electrical Connections.....	3-10
Transporting.....	3-11
Drawbar Connection.....	3-11
Boom Operation.....	3-12
Unfolding.....	3-12
Folding.....	3-13
Electric Recirculating Valve Operation.....	3-14
Manual Override for Electric Recirculating Valve.....	3-15
Filling Sprayer.....	3-16
Quick Fill.....	3-16
Tank Mixing.....	3-16
Rinsing Sprayer.....	3-17
Solution Tank.....	3-17
Boom Only Tank.....	3-17
Foam Marker.....	3-18
Filling.....	3-18
Foam Collector Height.....	3-18
Basic Operation.....	3-18
Chemical Inductor.....	3-19
Basic Operation.....	3-19
Chemical Container and Inductor Tank Rinsing.....	3-20
Electric Command Center.....	3-21
Filter Purge Controls.....	3-21
Pump Inlet/Outlet Controls.....	3-21
Fence Row Nozzle.....	3-22
XRT Autoboam Height Control.....	3-22
Steerable Hitch.....	3-22
Hydraulic Instructions.....	3-23
HYPRO Pump.....	3-23

Table of Contents

**Section IV
Maintenance**

Lubrication..... 4-2

Spray Pump - ACE HYD 750 Inflation..... 4-4

Sprayer Calibration - Verify Nozzle Flow..... 4-5

Equalizer® Track System..... 4-5

Wing Adjustments - 60' / 80' / 90' / 100' Booms..... 4-6

 Outer Wing Adjustments..... 4-6

 Wing Tilt Indicator Adjustment..... 4-6

 Wing Tip Breakaway Mechanism..... 4-7

 Boom Twin Link Suspension Adjustment..... 4-8

Wing Adjustments - 80' / 90' / 100' Booms..... 4-9

 Inner Wing Adjustment..... 4-9

 Inner Wing Alignment..... 4-9

 Wing Latch Pin..... 4-9

 Main Wing Fold Cylinder (60' Boom Included)..... 4-10

 Gull Wing Link..... 4-10

Wing Adjustments - 120' / 132' Booms..... 4-11

 Inner Wing Adjustments..... 4-11

 Intermediate Wing Adjustment..... 4-11

 Main Wing Fold Cylinder..... 4-12

 Outer Wing Adjustments..... 4-12

 Wing Tilt Indicator Adjustment..... 4-13

 Wing Tip Breakaway Mechanism..... 4-13

 Boom Twin Link Suspension Adjustment..... 4-14

Filters..... 4-15

 Self-Cleaning (Primary) Filter..... 4-15

 Secondary Filter..... 4-16

Foam Marker..... 4-17

 Filter Maintenance..... 4-17

Chemical Inductor..... 4-18

 Chemical Container and Inductor Tank Rinsing..... 4-18

Sprayer Maintenance..... 4-20

 Seasonal Storage..... 4-20

Winterizing..... 4-21

 Sprayer Plumbing..... 4-21

 Foam Marker (Optional)..... 4-22

 Chemical Inductor (Optional)..... 4-22

 Gauge Panel..... 4-22

Schematics..... 4-23

Wheel, Hub and Spindle Disassembly and Assembly..... 4-36

Wheels and Tires..... 4-38

 Wheel Nut Torque Requirements..... 4-38

 Tire Pressure..... 4-39

 Tire Warranty..... 4-39

Tracks - Warranty..... 4-40

Complete English and Metric Torque Chart..... 4-41

Hydraulic Fittings - Torque and Installation..... 4-42

Table of Contents

**Section V
Parts**

Decals	5-2
Frame & Tongue	5-4
Steerable Hitch Option	5-6
Standard Cast Hitch	5-9
Ladder	5-10
Platform, Railings - Models 1200 / 1600	5-12
Platform, Railings - Model 2400	5-14
Gauge Panel	5-16
Toolbox, Side Panels & Command Center Mounting	5-18
Axle	5-20
Suspended Axle	5-22
Hub & Spindle	5-24
Wheels & Tires - Models 1200 / 1600	5-26
Wheels & Tires - Model 2400	5-30
Equalizer Track Components - Model 1600	5-32
Equalizer Track Components - Model 2400	5-33
Mast	5-34
Lift Assembly, H-Frame	5-36
Command Center 4 Components	5-38
Command Center 4 Components (Optional Wireless Boom Control)	4-40
GEN 1 ISO Rate Control (RCM) Components	5-42
Hose Bracket	5-46
Strainer	5-47
Main Tank	5-48
Main Tank Plumbing	5-50
Front Plumbing Components - Models 1200 / 1600 / 2400	5-52
Rear Plumbing Components - Models 1200 / 1600 / 2400	5-54
Plumbing Overhead Layout - Models 1200 / 1600 / 2400	5-56
Hydraulic Valve Conversions	5-57
Hydraulic Valve	5-58
Inductor Plumbing (Optional)	5-60
Inductor Mounting (Optional)	5-64
Rinse Tank	5-66
Sight Gauge	5-68
Spray System & Command Center	5-70
Solution Tank Quick Fill	5-72
Spray Pump - ACE (304 PWM / 206) & Optional HYPRO	5-74
Spray Pump - (ACE HYD 750 PWM Plumbing)	5-76
PWM Pump - (ACE 750 PWM & ACE 755)	5-78
Spray Pump - (ACE FMCSC 205F HYD 304 PWM)	5-80
Spray Pump - (ACE FMCSC 150 HYD 206)	5-82
Spray Pump - (HYPRO 9306C-HM1C)	5-84
Foam Marker (Optional)	5-86
Foam Marker Assembly (Optional)	5-88
Double Drop Foam Marker Components (Optional)	5-90
Electric Controls (Optional)	5-92
Raven ISO Tank Fill Meter	5-94

FOR TRACK INFORMATION, PLEASE REFER TO YOUR TRACK MANUAL.

Section I Safety

General Hazard Information	1-2
Safety Decals	1-3
Following Safety Instructions	1-4
Before Servicing or Operating	1-5
During Operation	1-6
Before Transporting	1-6
During Transport.....	1-6
Pressurized Oil	1-7
Chemical Hazards	1-8
Access and Egress	1-8
Clean Water Tank.....	1-9
Preparing for Emergencies.....	1-10
Wearing Protective Equipment	1-10

General Hazard Information

No accident-prevention program can be successful without the wholehearted cooperation of the person who is directly responsible for the operation of the equipment.

A large number of accidents can be prevented only by the operator anticipating the result before the accident is caused and doing something about it. No power-driven equipment, whether it be transportation or processing, whether it is on the highway, in the field, or in the industrial plant, can be safer than the person who is at the controls. If accidents are to be prevented--and they can be prevented--it will be done by the operators who accept the full measure of their responsibility.

It is true that the designer, the manufacturer, and the safety engineer can help; and they will help, but their combined efforts can be wiped out by a single careless act of the operator.

It is said that, "the best kind of a safety device is a careful operator." We, at Unverferth Mfg. Co., Inc. ask that you be that kind of operator.



REMEMBER:
THINK SAFETY
A CAREFUL OPERATOR IS THE
BEST INSURANCE AGAINST AN
ACCIDENT!

SIGNAL WORDS



INDICATES AN EXTREMELY HAZARDOUS SITUATION OR ACTION THAT WILL RESULT IN SERIOUS INJURY OR DEATH.



INDICATES A HAZARDOUS SITUATION OR ACTION THAT COULD RESULT IN SERIOUS INJURY OR DEATH.



INDICATES AN UNSAFE SITUATION OR ACTION THAT MAY RESULT IN PERSONAL INJURY.



Is used for instruction on operating, adjusting, or servicing a machine.



Safety Decals

WARNING

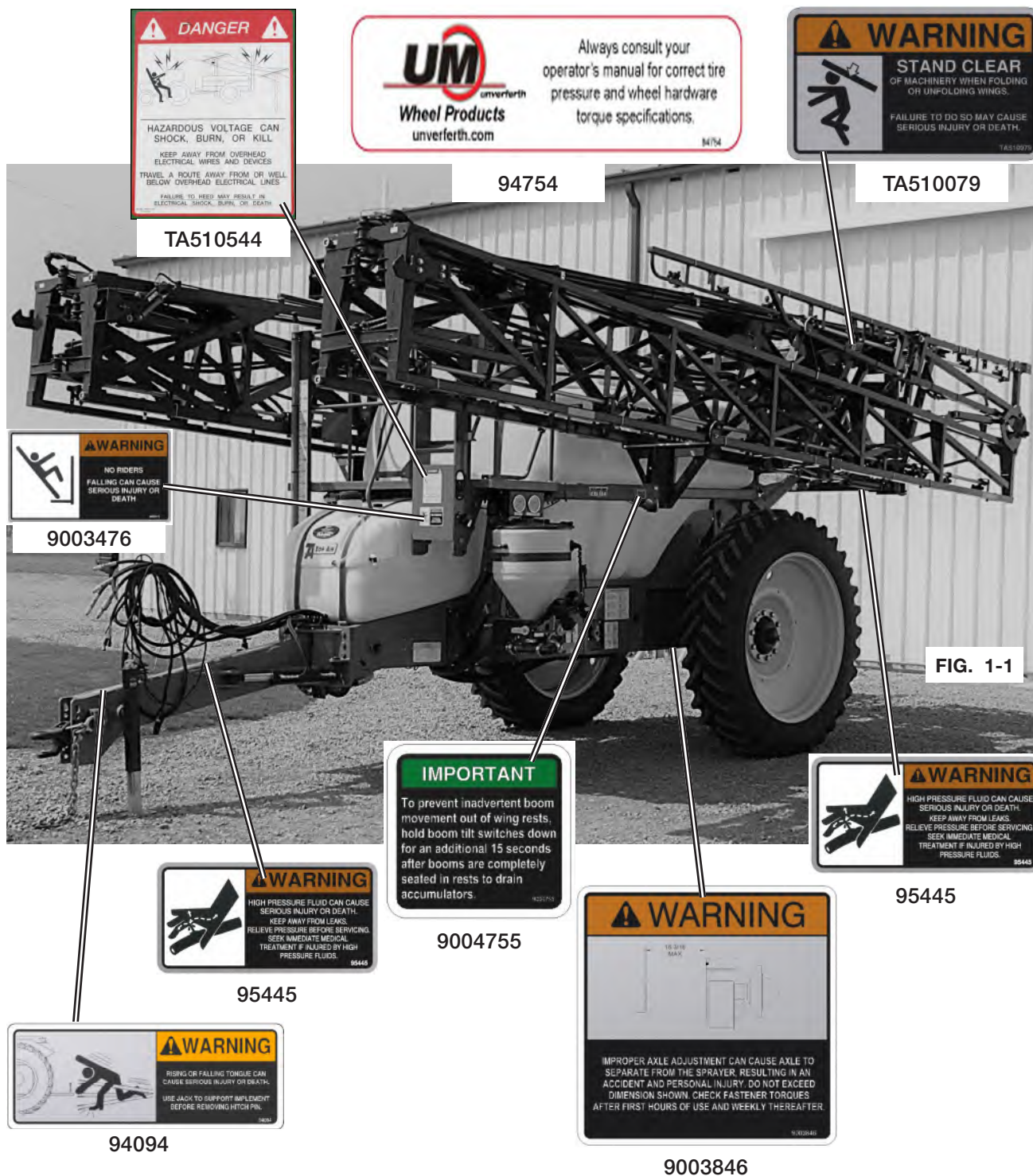

- REPLACE LOST, DAMAGED, PAINTED, OR UNREADABLE DECALS IMMEDIATELY. IF PARTS THAT HAVE DECALS ARE REPLACED, ALSO MAKE SURE TO INSTALL NEW DECALS. THESE DECALS INFORM AND REMIND THE OPERATOR WITH OPERATIONAL INFORMATION AND SAFETY MESSAGES.

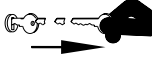

Following Safety Instructions

- Read and understand this operator's manual before operating. 
- All machinery should be operated only by trained and authorized personnel.
- To prevent machine damage, use only attachments and service parts approved by the manufacturer.
- Always shut tractor engine off and remove key before servicing. 
- Avoid personal attire such as loose fitting clothing, shoestrings, drawstrings, pants cuffs, long hair, etc., that may become entangled in moving parts.
- Do not allow anyone to ride on the implement. Make sure everyone is clear before operating machine or towing vehicle. 
- Never attempt to operate implement unless you are in the driver's seat. 

Before Servicing or Operating

- Do not stand between towing vehicle and implement during hitching. 
- Always make certain everyone and everything is clear of the machine before beginning operation.
- Sharp edges on the machine can cause injury. Be careful when working around the machine.
- Secure ball hitch latch with a locking device. Ensure that the towing vehicle drawbar has sufficient strength to support the draft and vertical tongue load of a fully-loaded sprayer.
- This sprayer is intended to only spray agricultural chemicals. Attempting to spray other liquids may cause equipment damage and introduce unexpected personal hazards.
- When operating sprayers on sidehill conditions, it is recommended that the wheel spacing be set as wide as possible for stability.
- Hitch sprayer to towing vehicle and clear all personnel from the surrounding area before folding and unfolding wings.
- Ensure tank access covers are fully closed before beginning or resuming operation.
- Avoid working under an implement; however, if it becomes absolutely unavoidable, make sure the implement is safely blocked. 
- Ensure that all applicable safety decals are installed and legible.
- To prevent personal injury or death always ensure that there are people who remain outside the sprayer to assist the person working inside, and that all safe work place practices are followed. There is restricted mobility and limited exit paths when working inside the implement.
- Secure drawbar pin with safety lock and lock tractor drawbar in fixed position.
- Explosive separation of a tire and rim can cause serious injury or death. Only properly trained personnel should attempt to service a tire and wheel assembly.
- Add sufficient ballast to tractor to maintain steering and braking control at all times. Do not exceed tractor's lift capacity or ballast capacity.
- Hitch sprayer to towing vehicle and clear all personnel from the surrounding area before folding and unfolding wings.
- Check all spray equipment for leaks. Repair any leaks before beginning or resuming operation.
- Residual pressure may exist in sprayer plumbing even when unit is not in use. Remove pressure before servicing any plumbing.
- Hot parts can cause severe burns. Use caution when working around power system/ground engaging components. Allow parts to cool before servicing.

During Operation

- Comply with all laws and product label directions governing safe product application.
- Regulate speed to working conditions. Maintain complete control at all times.
- Never service or lubricate equipment when in operation.
- Keep away from overhead power lines. Electrical shock can cause serious injury or death.
- Use extreme care when operating close to ditches, fences, or on hillsides.
- Do not leave towing vehicle unattended with engine running.

Before Transporting

- Secure transport chain to towing vehicle before transporting. **DO NOT** transport without chain.
- Check for proper function of all available transport lights. Make sure that all reflectors are clean and in place on machine. Make sure the SMV emblem and SIS decals are visible to approaching traffic.
- This implement is not equipped with brakes. Ensure that the towing vehicle has adequate weight and braking capacity to tow this unit.

During Transport

- Comply with all laws governing highway safety when moving machinery.
- Use transport lights as required by all laws to adequately warn operators of other vehicles.
- Regulate speed to road conditions and maintain complete control.
- Maximum transport speed of this implement should never exceed 20 mph with wheels or 15 mph with tracks as indicated on the machine. Maximum transport speed of any combination of implements must not exceed the lowest specified speed of the implements in combination. Do not exceed 10 mph during off-highway travel.
- Slow down before making sharp turns to avoid tipping. Drive slowly over rough ground and side slopes.
- It is probable that this implement is taller, wider and longer than the towing vehicle. Become aware of and avoid all obstacles and hazards in the travel path of the equipment, such as power lines, ditches, etc.

Pressurized Oil

- Relieve pressure before disconnecting hydraulic lines from the tractor, loosening any hydraulic fittings or servicing hydraulic system. See hydraulic power unit manual for procedure to relieve pressure.

- High-pressure fluids can penetrate the skin and cause serious injury or death. Leaks of high-pressure fluids may not be visible. Use cardboard or wood to detect leaks in the hydraulic system. Seek medical treatment immediately if injured by high-pressure fluids. 

- Accumulators used in this hydraulic system can retain fluid under pressure even after tractor hydraulic valve is placed in FLOAT. Remove residual pressure from wing tilt and main lift accumulators by holding wing tilt and main lift switches in DOWN position for at least 20 seconds after cylinders have stopped moving.

- Hydraulic system must be purged of air before operating to prevent serious injury or death.

- Do not bend or strike high-pressure lines. Do not install bent or damaged tubes or hoses.

- Repair all oil leaks. Leaks can cause fires, personal injury, and environmental damage.

- Route hoses and lines carefully to prevent premature failure due to kinking and rubbing against other parts. Make sure that all clamps, guards and shields are installed correctly.

- Check hydraulic hoses and tubes carefully. Replace components as necessary if any of the following conditions are found:
 - o End fittings damaged, displaced, or leaking.
 - o Outer covering chafed/cut or wire reinforcing exposed.
 - o Outer covering ballooning locally.
 - o Evidence of kinking or crushing of the flexible part of a hose.

Chemical Hazards

- Always wear personal protective equipment when working with or near chemicals. This equipment includes, but is not limited to: protective eye wear, gloves, shoes, socks, long-sleeved shirt, and long pants. Additional protection may be required for many types of chemicals.
- Spray tanks may contain residual toxic chemicals. **DO NOT ENTER SPRAY TANK FOR ANY REASON WITHOUT WEARING PROPER VENTILATION EQUIPMENT.** Failure to do so may result in asphyxiation and death.
- Seek and receive chemical product training prior to using agricultural chemicals
- Read and understand the entire label of every chemical being applied with this sprayer.
- Avoid breathing spray mist or vapor.
- Wash hands and exposed skin immediately after contact with spray/fertilizer solution and application equipment.
- Remove clothing immediately if chemicals penetrate clothing and contact skin. Wash thoroughly and put on clean clothing.
- Dispose of unused chemical in accordance with chemical label directions and local/national regulations.

Access and Egress

- Mount and dismount the sprayer only where steps and/or hand holds are provided.
- Face the sprayer when mounting and dismounting.
- Inspect, and when necessary, clean and have repairs made to steps and hand holds before mounting and dismounting.
- Never get on or off a moving sprayer.
- Never jump off the sprayer.
- Do not try to climb on or off the sprayer when carrying tools or supplies.

Clean Water Tank

- A clean water tank is provided as standard equipment. It is equipped with a spigot for general washing and a hose for emergency eye washing.
- Always keep clean water in tank. Water in clean water tank is not suitable for human consumption.
- For emergency eyewash, pull hose off of the top fitting and flush affected area.

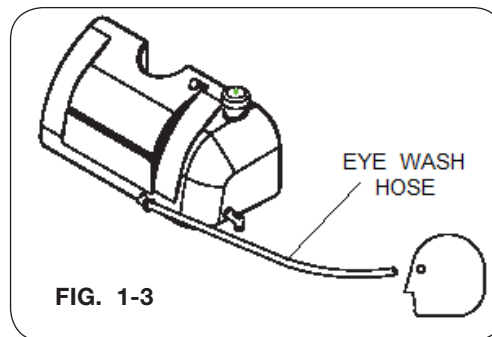
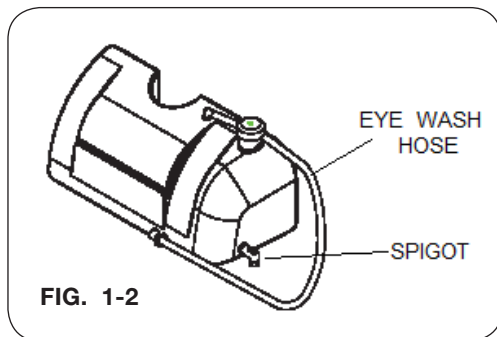

Preparing for Emergencies

- Keep a first aid kit and properly rated fire extinguisher nearby.



- Keep emergency numbers for fire, rescue, and poison control personnel near the phone.



Wearing Protective Equipment

- Wear clothing and personal protective equipment appropriate for the job.



- Wear steel-toed shoes when operating.



- Wear hearing protection when exposed to loud noises.



- Do not wear additional hearing impairing devices such as radio headphones, etc.



Section II Set Up

Pre-Delivery Checklist.....	2-2
Dealer Set Up.....	2-3
Remove Shipping Axle Capscrews.....	2-3
Installing Drain Plug.....	2-4
Rotate Wing Hose Brackets (120' & 132' Boom Only).....	2-4
Boom Rest Brackets For Model TA1600 Only.....	2-5
Tongue Adjustment.....	2-6
Units With Fixed Position Hitch.....	2-6
Units With Steerable Hitch.....	2-6
Axle Tread Setting.....	2-7
Wheel Spacing Combinations.....	2-7
Adjustment.....	2-9
Tracks Toe In Adjustment.....	2-12
Equalizer® Track System.....	2-14
Installing Boom Control Box.....	2-14
Installing Rate Controller.....	2-14
Boom Functions.....	2-15
Setting Flow.....	2-15
Rate Control Module (RCM) Set Up.....	2-16
Flow Meter Calibration.....	2-23
Catch Test Calibration.....	2-23
Applied Product Calibration.....	2-25
Nozzle Flow Check.....	2-27
Control Box.....	2-30
Command Center 4 System Set Up.....	2-31
Procedure For Linking Radio And Receiver.....	2-31
Hydraulic Manifold Set Up.....	2-32
Set Up For Power Beyond Connection.....	2-32
Closed-Center Conversion Kit.....	2-33
Setting the Pump Pressure - PWM.....	2-34
Setting the Pump Pressure - Non-PWM.....	2-35
Sprayer Calibration.....	2-36
Determine Required Nozzle Size.....	2-36
Electric Command Center Installation.....	2-37
XRT Autoboom Height Control.....	2-40
Steerable Hitch.....	2-40

Pre-Delivery Checklist

- Power wash any road salt off this unit to help prevent corrosion.
- Remove shipping axle capscrews under the frame. Refer to “Remove Shipping Axle Capscrews ” on the next page.
- Torque wheel nuts as specified in MAINTENANCE section.
- Verify track has been aligned and is properly conditioned. Refer to Equalizer® Track sprayer manual MAINTENANCE section for alignment information. (If applicable)
- Check tire pressure and inflate tires as needed to specified air pressure. See “Tire Pressure” in MAINTENANCE section. (if applicable)
- Torque hardware as specified in MAINTENANCE section.
- Verify all safety decals are correctly located and legible. Replace if damaged.
- Verify all reflective decals are correctly located.
- Check SMV emblem and SIS decals are in place, clean and visible.
- Verify transport lights are working properly.
- Install transport chain and torque hardware to specification. See “Transport Chain Connection” in OPERATION section.
- Check hydraulic components for leaks and check hose routing.
- Check all plumbing components for leaks.
- Paint all parts scratched during shipment and dealer set up.

Dealer Set Up

Remove Shipping Axle Capscrews

WARNING

- TIPPING OR MOVEMENT OF THE MACHINE CAN CAUSE SERIOUS INJURY OR DEATH. BE SURE MACHINE IS SECURELY BLOCKED.
- EYE PROTECTION AND OTHER APPROPRIATE PERSONAL PROTECTIVE EQUIPMENT MUST BE WORN WHILE SERVICING IMPLEMENT.
- KEEP HANDS CLEAR OF PINCH POINT AREAS.
- FALLING OBJECTS CAN CAUSE SERIOUS INJURY OR DEATH. DO NOT WORK UNDER THE MACHINE AT ANY TIME WHILE BEING HOISTED. BE SURE ALL LIFTING DEVICES AND SUPPORTS ARE RATED FOR THE LOADS BEING HOISTED. THESE ASSEMBLY INSTRUCTIONS WILL REQUIRE SAFE LIFTING DEVICES UP TO 16,000 LBS. SPECIFIC LOAD RATINGS FOR INDIVIDUAL LOADS WILL BE GIVEN AT THE APPROPRIATE TIME IN THE INSTRUCTIONS.

NOTE: Shipping axle capscrews must be removed if changing axle spacing.

1. Park empty unit on a firm, level surface. Block the machine to keep it from moving. Set vehicle's parking brake, shut off the engine, remove the ignition key and disconnect hydraulics from towing vehicle to the machine.

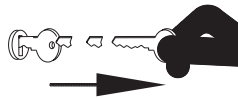

2. Using a safe lifting device rated for 16,000 lbs., raise the machine. Place supports rated for 16,000 lbs. under the frame panel near the axle tubes.
3. Remove and discard 3/4"-10UNC shipping capscrews (9390-144) and 3/4" yellow washers (417646Y) retaining the axles. (FIGS. 2-1 & 2-2)

NOTE: For wheel units, there are two capscrews and washers located on the frame tubes by the axle clamps. (FIG. 2-1)

For track units, there are four capscrews and washers. One set is located on the frame tubes by the axle clamps. The other set is located below the axle clamps of the track fork tubes. (FIGS. 2-1 & 2-2)

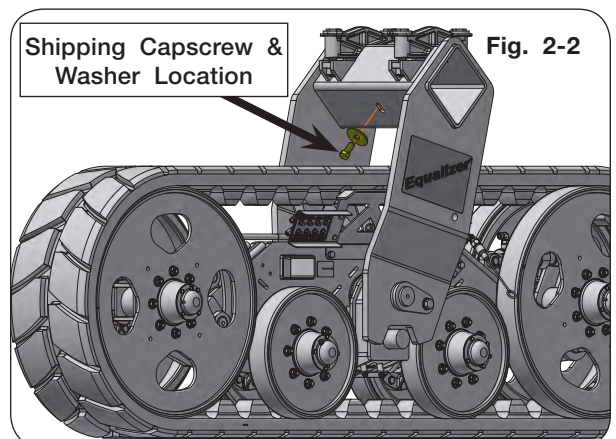
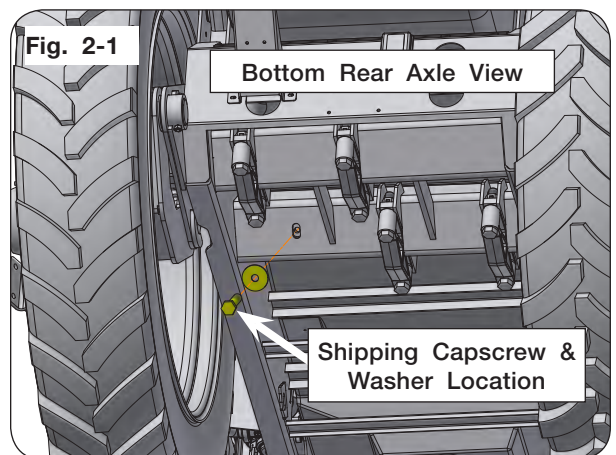

Dealer Set Up (continued)

Installing Drain Plug

IMPORTANT

- *Install drain plug prior to operation.*

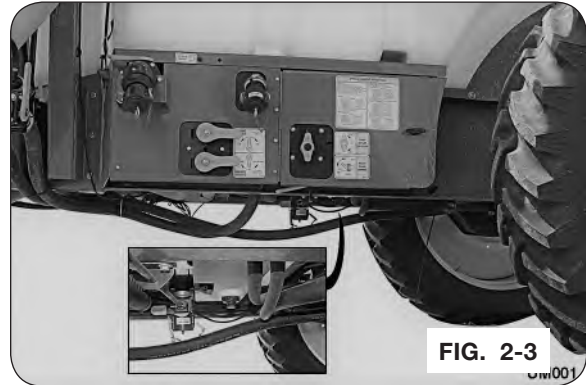

Rotate Wing Hose Brackets (120' and 132' Boom Only)

1. Rotate bracket vertically.
2. Run hoses through bracket.



Dealer Set Up (continued)

Boom Rest Brackets for Model TA1600 Only

⚠ WARNING

- **TIPPING OR MOVEMENT OF THE MACHINE CAN CAUSE SERIOUS INJURY OR DEATH. BE SURE MACHINE IS SECURELY BLOCKED.**
- **EYE PROTECTION AND OTHER APPROPRIATE PERSONAL PROTECTIVE EQUIPMENT MUST BE WORN WHILE SERVICING IMPLEMENT.**
- **KEEP HANDS CLEAR OF PINCH POINT AREAS.**
- **FALLING OBJECTS CAN CAUSE SERIOUS INJURY OR DEATH. DO NOT WORK UNDER THE MACHINE AT ANY TIME WHILE BEING HOISTED. BE SURE ALL LIFTING DEVICES AND SUPPORTS ARE RATED FOR THE LOADS BEING HOISTED. THESE ASSEMBLY INSTRUCTIONS WILL REQUIRE SAFE LIFTING DEVICES UP TO 50 LBS. SPECIFIC LOAD RATINGS FOR INDIVIDUAL LOADS WILL BE GIVEN AT THE APPROPRIATE TIME IN THE INSTRUCTIONS.**

To minimize shipping height from the factory, the wing rests are installed in the lowest position as shown in FIG. 2-5. Use the following procedure to reposition the wing rests prior to first use.

1. Park empty unit on a firm, level surface. Block the machine to keep it from moving. Set tractor's parking brake, shut off the engine, and remove the ignition key.

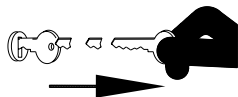

2. Hitch sprayer to tractor. Refer to "Hitching to Tractor" in OPERATION section.
3. Fully extend boom.
4. Use a safe lifting device rated for 50 lbs. to support the wing rest for repositioning.
5. Remove four bolts indicated in FIG. 2-5.
6. Move wing rests to holes indicated in FIG. 2-6 and reinstall bolts.
7. Torque hardware to appropriate requirements as outlined in the MAINTENANCE section of this manual.

FIG. 2-5

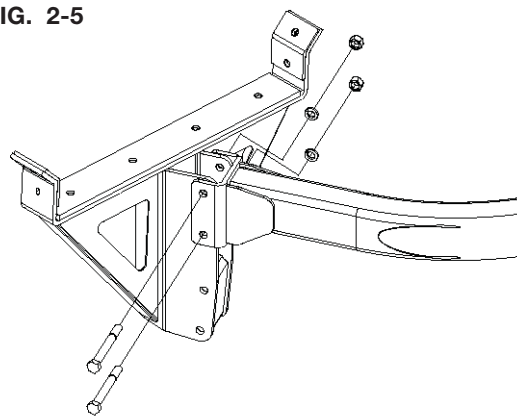
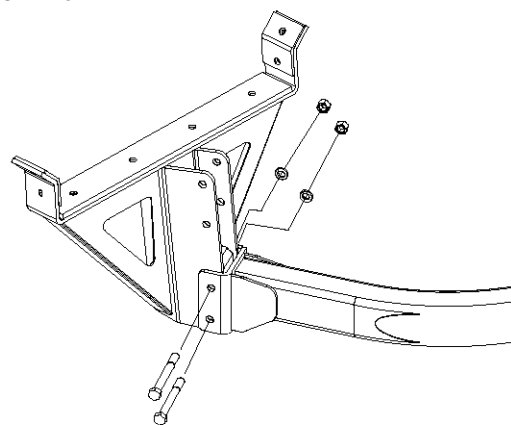

FIG. 2-6



Tongue Adjustment

Units with Fixed Position Hitch

1. Pull sprayer in a straight line for a few hundred feet to determine how the sprayer is trailing.
2. If unit is trailing to the left, lengthen the RH tongue turnbuckle and shorten the LH tongue turnbuckle.
3. If unit is trailing to the right, lengthen the LH tongue turnbuckle and shorten the RH tongue turnbuckle.

Units Equipped with Steerable Hitch

1. With the telescoping tongue transport locked (spring loaded lock pin in down position), pull sprayer in straight line for a few hundred feet to determine how the sprayer is trailing.
2. Set the manual bump rate to 0.5 degrees as follows:

ISO bus:

- a. On the Steerable Hitch Page select TUNING.
 - b. Select BUMP RATE and decrease to 0.5.
3. Unlock the telescoping tongue transport lock by pulling up on the spring loaded lock pin and turn to secure pin in the up position.
 4. If unit is trailing to the left push the manual control switch on the sprayer control box to R and release. If unit is trailing to the right push the manual control switch on the sprayer control box to L and release.
 5. Pull sprayer in straight line for a few hundred feet to determine how the sprayer is trailing.
 6. Repeat steps 4 & 5 until sprayer trails properly.
 7. Release telescoping tongue lock pin by pulling up and turning to align roll pin with long vertical slot.
 8. Loosen jam nut on the inner telescoping tongue lock tube.
 9. Rotate the inner telescoping tongue lock tube until lock pin falls freely through hole engaging telescoping lock.
 10. Tighten jam nut on the inner telescoping tongue lock tube.
 11. Perform tongue set-up/calibration procedures described in the Raven Steerable Hitch Manual.
 12. Repeat step 2 to reset the manual bump rate to the desired bump rate.

Axle Tread Setting

Wheel Spacing Combinations

WARNING

- USE EXCEPTIONAL CARE WHEN OPERATING SPRAYER EQUIPPED WITH SINGLE TIRES AND SET AT NARROW WHEEL SPACING. THE POSSIBILITY OF TIPPING OVER DURING TURNS OR TRAVEL ON ROUGH ROADS IS INCREASED UNDER THESE CONDITIONS.

NOTE: Shipping axle capscrews must be removed if changing axle spacing. Refer to “Dealer Set Up - Remove Shipping Axle Capscrews” in this section for details.

The axle spacing is infinitely adjustable between minimum and maximum settings. Through a combination of wheel offset, axle adjustment, and hub spacers, a wide variety of single and dual wheel spacings is possible. A summary of the available wheel spacings for each tire and wheel combination is located on the next page.

Axle Tread Setting (continued)

WHEEL OFFSET TO OUTSIDE								
TIRE / WHEEL	1200 STANDARD AXLE		1200 w/AXLE SUSPENSION		1600		2400	
	MIN. SPACING (inches)	MAX. SPACING (inches)	MIN. SPACING (inches)	MAX. SPACING (inches)	MIN. SPACING (inches)	MAX. SPACING (inches)	MIN. SPACING (inches)	MAX. SPACING (inches)
320/90 x 46 Single	83	144	94	128	-	-	-	-
380/90 x 46 Single 5" Offset	76	136	87	121	89	121	-	-
480/80 x 42 Single	75	135	88	120	89	120	-	-
320/90 x 50 Single	-	-	-	-	96	136	-	-
320/90 x 46 Duals (20" Rows)	100 Outer Dual	162 Outer Dual	100 Outer Dual	144 Outer Dual	100 Outer Dual	141 Outer Dual	-	-
320/90 x 46 Duals (22" Rows)	104 Outer Dual	166 Outer Dual	104 Outer Dual	148 Outer Dual	104 Outer Dual	144 Outer Dual	-	-
320/90 x 46 Duals (30" Rows)	120 Outer Dual	182 Outer Dual	120 Outer Dual	164 Outer Dual	120 Outer Dual	160 Outer Dual	-	-
380/90 x 46 Duals (20" Rows)	-	-	-	-	100 Outer Dual	141 Outer Dual	-	-
380/90 x 46 Duals (22" Rows)	-	-	-	-	104 Outer Dual	144 Outer Dual	-	-
380/90 x 46 Duals (30" Rows)	120 Outer Dual	182 Outer Dual	120 Outer Dual	164 Outer Dual	120 Outer Dual	160 Outer Dual	-	-
320/90 x 50 Duals (22" Rows)	-	-	-	-	104 Outer Dual	144 Outer Dual	104 Outer Dual	144 Outer Dual
320/90 x 50 Duals (30" Rows)	-	-	-	-	120 Outer Dual	160 Outer Dual	-	-
480/80 x 42 Duals (30" Rows)	-	-	-	-	120 Outer Dual	160 Outer Dual	-	-
380/90 x 54 Duals (22" Rows)	-	-	-	-	104 Outer Dual	144 Outer Dual	104 Outer Dual	144 Outer Dual
380/90 x 54 Duals (30" Rows)	-	-	-	-	-	-	120 Outer Dual	160 Outer Dual
480/80 x 50 Duals (30" Rows)	-	-	-	-	-	-	120 Outer Dual	160 Outer Dual
Horizontal Tracks	-	-	-	-	88	132	88	132
WHEEL OFFSET TO INSIDE								
TIRE / WHEEL	1200 STANDARD AXLE		1200 w/AXLE SUSPENSION		1600		2400	
	MIN. SPACING (inches)	MAX. SPACING (inches)	MIN. SPACING (inches)	MAX. SPACING (inches)	MIN. SPACING (inches)	MAX. SPACING (inches)	MIN. SPACING (inches)	MAX. SPACING (inches)
320/90 x 46 Single	70	110	70	95	-	-	-	-
380/90 x 46 Single 5" Offset	70	116	70	102	70	101	-	-
480/80 x 42 Single	70	118	-	-	-	-	-	-
320/90 x 50 Single	-	-	-	-	70*	105	-	-
320/90 x 46 Duals	60 Inner Dual	122 Inner Dual	60 Inner Dual	104 Inner Dual	60 Inner Dual	101 Inner Dual	-	-
380/90 x 46 Duals	60 Inner Dual	122 Inner Dual	60 Inner Dual	104 Inner Dual	60 Inner Dual	101 Inner Dual	-	-
320/90 x 50 Duals	-	-	-	-	63 Inner Dual	104 Inner Dual	62 Inner Dual	103 Inner Dual
480/80 x 42 Duals	-	-	-	-	87 Inner Dual	128 Inner Dual	-	-
380/90 x 54 Duals	-	-	-	-	-	-	62 Inner Dual	103 Inner Dual
480/80 x 50 Duals	-	-	-	-	-	-	61 Inner Dual	102 Inner Dual
Horizontal Tracks	-	-	-	-	88	132	88	132

Axle Tread Setting (continued)

Adjustment

WARNING

- IMPROPER AXLE ADJUSTMENT CAN CAUSE AXLE TO SEPARATE FROM SPRAYER, RESULTING IN PERSONAL INJURY OR DEATH DUE TO SPRAYER OR AXLE FALLING.
- USE CARE THAT SPRAYER DOES NOT FALL FROM SUPPORT STANDS DURING ADJUSTMENT. DO NOT ALLOW AXLE TO SEPARATE FROM SPRAYER DURING ADJUSTMENT PROCEDURE.
- FALLING OBJECTS CAN CAUSE SERIOUS INJURY OR DEATH. DO NOT WORK UNDER THE MACHINE AT ANY TIME WHILE BEING HOISTED. BE SURE ALL LIFTING DEVICES AND SUPPORTS ARE RATED FOR THE LOADS BEING HOISTED. THESE ASSEMBLY INSTRUCTIONS WILL REQUIRE SAFE LIFTING DEVICES UP TO 16,000 LBS. SPECIFIC LOAD RATINGS FOR INDIVIDUAL LOADS WILL BE GIVEN AT THE APPROPRIATE TIME IN THE INSTRUCTIONS.
- EYE PROTECTION AND OTHER APPROPRIATE PERSONAL PROTECTIVE EQUIPMENT MUST BE WORN WHILE SERVICING IMPLEMENT.
- KEEP HANDS CLEAR OF PINCH POINT AREAS.

CAUTION

- IMPROPERLY TORQUED WHEEL NUTS/BOLTS CAN CAUSE A LOSS OF IMPLEMENT CONTROL AND MACHINE DAMAGE. TORQUE WHEEL NUTS/BOLTS TO VALUES IN TABLE. CHECK TORQUE BEFORE USE, AFTER ONE HOUR OF UNLOADED USE OR AFTER FIRST LOAD, AND EACH LOAD UNTIL WHEEL NUTS/BOLTS MAINTAIN TORQUE VALUE. CHECK TORQUE EVERY 10 HOURS OF USE THERE-AFTER. AFTER EACH WHEEL REMOVAL START TORQUE PROCESS FROM BEGINNING. WARRANTY DOES NOT COVER FAILURES CAUSED BY IMPROPERLY TORQUED WHEEL NUTS/BOLTS.

Axle Tread Setting (continued)

Adjustment (continued)

IMPORTANT

- Always adjust axles equally.

NOTE: Shipping axle capscrews must be removed if changing axle spacing. Refer to “Dealer Set Up - Remove Shipping Axle Capscrews” in this section for details.

1. Park empty unit on a firm, level surface. Block the machine to keep it from moving. Set tractor's parking brake, shut off the engine, and remove the ignition key.
2. Hitch sprayer to tractor to help stabilize unit.
3. Using a safe lifting device rated for 16,000 lbs. and safety stands rated for 16,000 lbs., raise sprayer and place on stands. Stands should be securely positioned under frame rails, as far toward the rear of the sprayer as practical.
4. **Units with tracks, skip to step 5.**



- Unit with wheels, if necessary for desired wheel spacing, change wheel dish direction by unbolting wheels and swap between left and right sides on sprayer. Refer to information in wheel spacing chart to see if wheel dish needs to be reversed. Tighten 7/8" wheel lug bolts to 440 ft-lbs. torque.**
5. Loosen four 1" clamp bolts that hold one axle. Using a safe lifting device rated for 3,000 lbs., lift the wheel slightly and slide axle out until desired adjustment is reached.
 6. Verify that the axle is not over-extended. (The inner axle clamp should fully contact the axle.)
 7. After adjustment, tighten 1" threaded fasteners to a torque of 500 ft-lbs.
 8. Repeat steps 4 through 6 for other axle.

Axle Tread Setting (continued)

Track Tread Toolbar Widths

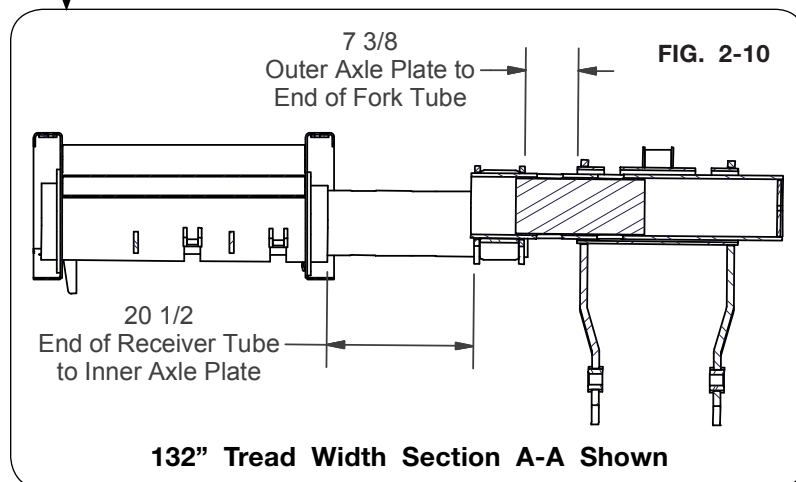
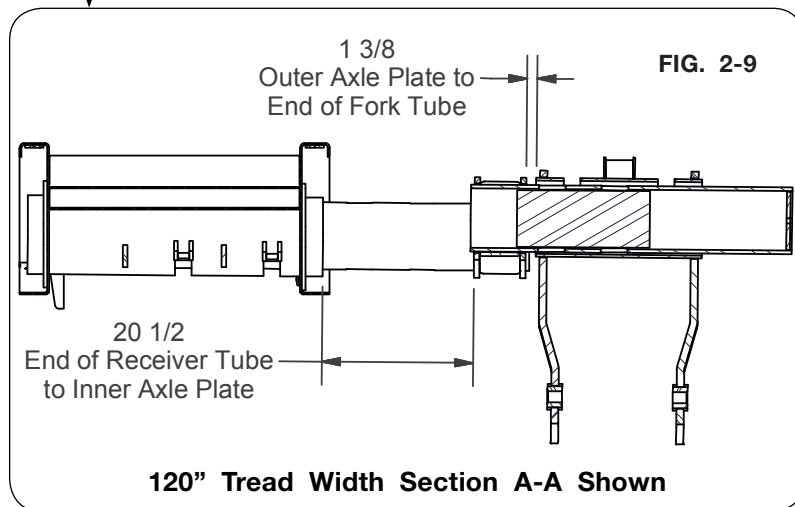
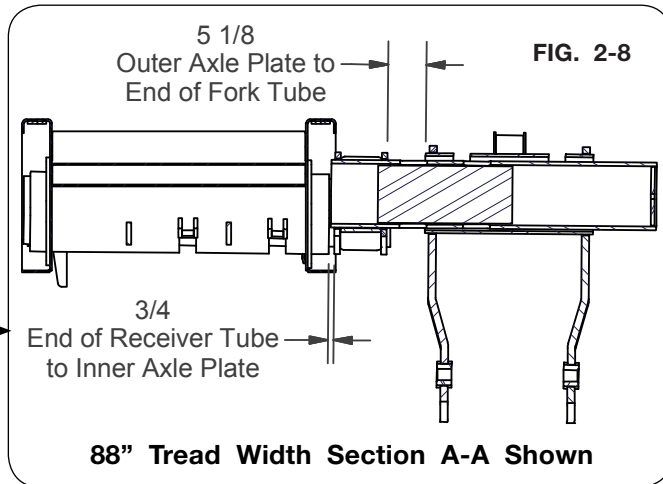
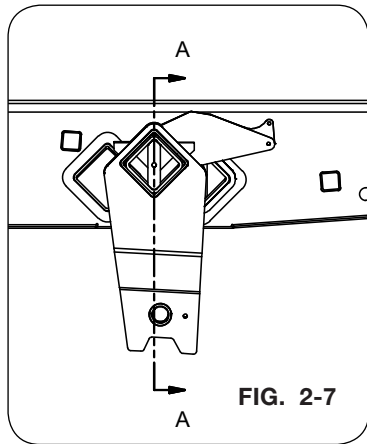

Axle Tread Setting (continued)

Tracks Toe In Adjustment

WARNING

- IMPROPER AXLE ADJUSTMENT CAN CAUSE AXLE TO SEPARATE FROM SPRAYER, RESULTING IN PERSONAL INJURY OR DEATH DUE TO APPLICATOR OR AXLE FALLING.
- USE CARE THAT SPRAYER DOES NOT FALL FROM SUPPORT STANDS DURING ADJUSTMENT. DO NOT ALLOW AXLE TO SEPARATE FROM SPRAYER DURING ADJUSTMENT PROCEDURE.
- FALLING OBJECTS CAN CAUSE SERIOUS INJURY OR DEATH. DO NOT WORK UNDER THE MACHINE AT ANY TIME WHILE BEING HOISTED. BE SURE ALL LIFTING DEVICES AND SUPPORTS ARE RATED FOR THE LOADS BEING HOISTED. THESE ASSEMBLY INSTRUCTIONS WILL REQUIRE SAFE LIFTING DEVICES UP TO 16,000 LBS. SPECIFIC LOAD RATINGS FOR INDIVIDUAL LOADS WILL BE GIVEN AT THE APPROPRIATE TIME IN THE INSTRUCTIONS.
- EYE PROTECTION AND OTHER APPROPRIATE PERSONAL PROTECTIVE EQUIPMENT MUST BE WORN WHILE SERVICING IMPLEMENT.
- KEEP HANDS CLEAR OF PINCH POINT AREAS.

CAUTION

- IMPROPERLY TORQUED WHEEL NUTS/BOLTS CAN CAUSE A LOSS OF IMPLEMENT CONTROL AND MACHINE DAMAGE. TORQUE WHEEL NUTS/BOLTS TO VALUES IN TABLE. CHECK TORQUE BEFORE USE, AFTER ONE HOUR OF UNLOADED USE OR AFTER FIRST LOAD, AND EACH LOAD UNTIL WHEEL NUTS/BOLTS MAINTAIN TORQUE VALUE. CHECK TORQUE EVERY 10 HOURS OF USE THERE-AFTER. AFTER EACH WHEEL REMOVAL START TORQUE PROCESS FROM BEGINNING. WARRANTY DOES NOT COVER FAILURES CAUSED BY IMPROPERLY TORQUED WHEEL NUTS/BOLTS.

Axle Tread Setting (continued)

Tracks Toe In Adjustment (continued)

IMPORTANT

- Always adjust axles equally.
1. Park empty unit on a firm, level surface. Block the machine to keep it from moving. Set vehicle's parking brake, shut off the engine, remove the ignition key and disconnect hydraulics from the towing vehicle to the machine. Hitch sprayer to tractor to help stabilize unit. Refer to "Hitching to Tractor" in OPERATION section.



2. Using a safe lifting device and supports rated for 16,000 lbs., raise one side of the empty sprayer and place on stands. Stands should be securely positioned under both frame rails, as far toward the rear of the sprayer as practical. (FIG. 2-11)

NOTE: Measure from one track to the other to determine if the track axle requires a shim.

3. Measure from front idler to front idler on opposite side and from rear idler to rear idler on opposite side.
4. Next, measure from front left idler to rear right idler and then the opposite dimension.

NOTE: For a toe in adjustment, the front idler measurement will be slightly less than the rear idler measurement. However, the "X" measurement from step 4 will be equal.

5. To establish toe in, install 14 gauge, 12 gauge or 10 gauge shim (411103B, 411098B or 411105B) on the upper rear side of the track diamond axle between the axle and sprayer frame. (FIG. 2-12)
6. Using a safe lifting device rated for 3,000 lbs., loosen four 1" clamp bolts that hold one axle. Lift the axle slightly and slide in shim for desired toe in adjustment.

NOTE: Do not extend axle beyond the clamps.

7. After adjustment, tighten 1" clamp bolts to a torque of 500 ft-lbs.
8. Repeat steps 2 through 6 for other axle. Remove safe lifting devices and supports.

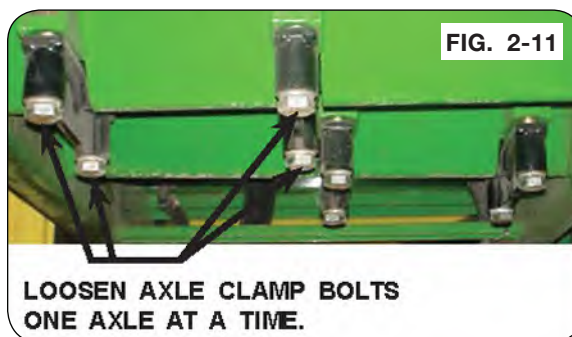

Equalizer® Track System

Refer to the Equalizer® Track System sprayer manual for information regarding the track.

Installing Boom Control Box

1. Mount the boom control box in the cab.
2. Connect wiring harness at the hitch.
3. Run harness into the cab.
4. Attach the other end of the wiring harness to the back of the boom control box.
5. Connect red and white wires to a 12V power source. Red is the positive and white is the ground.

Installing Rate Controller (If applicable)

1. Mount the controller in the cab.
2. Connect wiring harness at the hitch.
3. Run harness into the cab.
4. Attach the other end of the wiring harness to the back of the controller.
5. Connect red and white wires to a 12V power source. Red is the positive and white is the ground.

Boom Functions

Setting Flow

1. Adjust circuit flow to minimum setting prior to operating circuit for first time.
2. Turn on the fold box.
3. Move hydraulic lever to RETRACT to start oil flow.
4. Hold the left wing tilt switch in the up position.
5. Slowly increase the flow until the boom starts to move.
6. Release the wing tilt button.
7. Use the left wing tilt switch to lower the left wing back into the cradle.
8. Disengage hydraulics by pushing lever into float.

IMPORTANT

- *Flow will be approximately 2-4 gpm.*

Rate Control Module (RCM) Set Up

When turning on the RCM for the first time, the 12V DC power is turned off, or the ECU for the sprayer loses power, the following steps will have to be performed in order for the RCM to function properly right away.

NOTE: Before programming the RCM, ensure the RCM monitor is connected to the battery.

1. On the initial start-up screen, begin by entering the profile name for your pull-behind sprayer (Fig. 2-13)
2. Select “Pull-Behind Sprayer” as the desired machine type from the drop down menu.
3. Enter the application width of your sprayer in inches. Refer to Boom Calibration table below if unknown.
4. Press the Next Page icon.

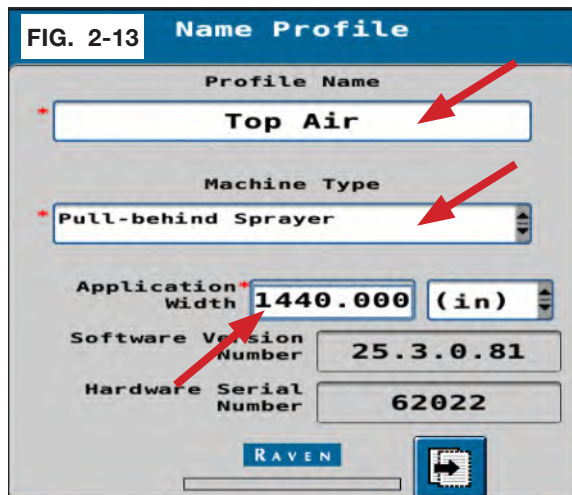

NOTE: Highest value for Application Width is 1584 in.

Boom Calibration Numbers

Boom Width	Spacing	# of Sections	Total Width	Section 1	Section 2	Section 3	Section 4	Section 5	Section 6	Section 7	Section 8	Section 9	Section 10
80'	20"	6	960"	120"	120"	240"	240"	120"	120"	-	-	-	-
80'	15"	6	975"	120"	120"	240"	255"	120"	120"	-	-	-	-
90'	20"	6	1080"	180"	160"	200"	200"	160"	180"	-	-	-	-
90'	15"	6	1095"	180"	165"	195"	210"	165"	180"	-	-	-	-
90'	20"	10	1080"	60"	120"	120"	120"	120"	120"	120"	120"	120"	60"
90'	15"	10	1095"	60"	120"	120"	120"	120"	135"	120"	120"	120"	60"
100'	20"	6	1200"	240"	160"	200"	200"	160"	240"	-	-	-	-
100'	15"	6	1215"	240"	165"	195"	210"	165"	240"	-	-	-	-
100'	20"	10	1200"	120"	120"	120"	120"	120"	120"	120"	120"	120"	120"
100'	15"	10	1215"	120"	120"	120"	120"	120"	135"	120"	120"	120"	120"
120'	20"	6	1440"	180"	260"	280"	280"	260"	180"	-	-	-	-
120'	15"	6	1455"	180"	270"	285"	270"	270"	180"	-	-	-	-
120'	20"	10	1440"	60"	120"	180"	180"	180"	180"	180"	180"	120"	60"
120'	15"	10	1455"	60"	120"	180"	180"	195"	180"	180"	180"	120"	60"
132'	22"	6	1584"	264"	264"	264"	264"	264"	264"	-	-	-	-

Rate Control Module (RCM) Set Up (continued)

5. Default for “ECU” box is 1. (Fig. 2-14)
6. For “Number of Products” enter 1. (Fig. 2-14)
7. Press the Next Page icon.

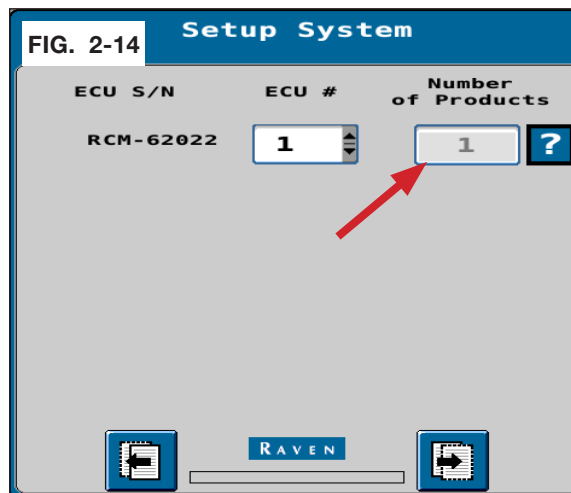

8. Under Application Mode, select “Liquid”. (Fig. 2-15)
9. Press the Next Page icon.

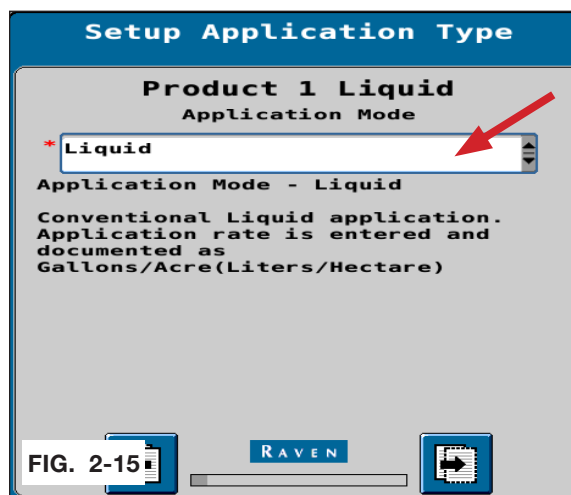

10. Ensure both the “Weather Station Enabled” and “AUX-N Enabled” boxes are unchecked. (Fig. 2-16)
11. Press the Next Page icon.

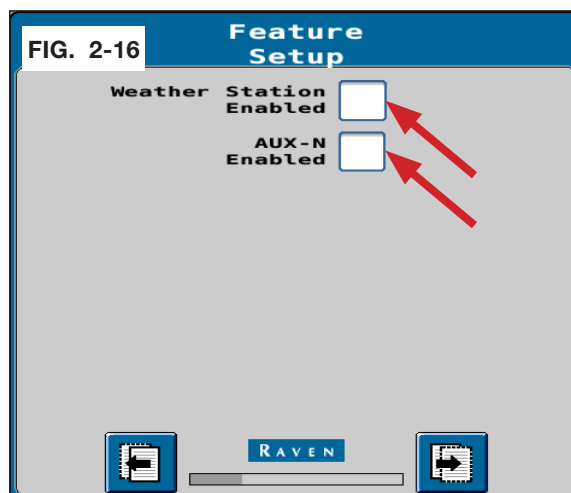

Rate Control Module (RCM) Set Up (continued)

12. Enter the number of sections. Ensure both the “Equal Width Sections” and “Fence Rows Enable” boxes are unchecked. (Fig. 2-17)

13. Under Section Valve Type, select “3-Wire”. (Fig. 2-17)

NOTE: If unsure of the number of sections, this can also be determined by counting the number of ball valves in the valve manifold located in the center of the boom.

14. Press the Next Page icon.

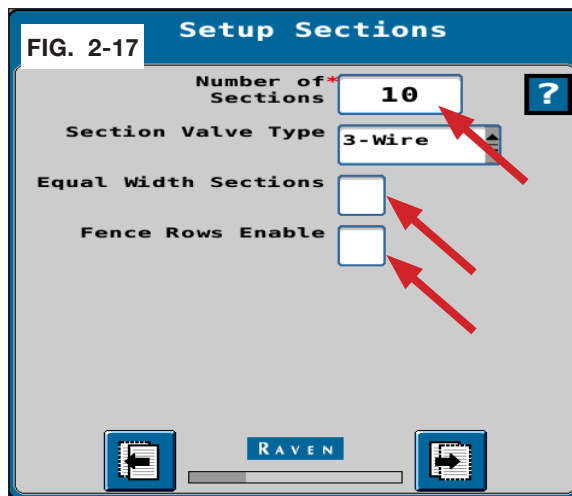

15. Verify or enter the widths of the individual sections. See “Boom Calibration Numbers” chart at the beginning of this section for specific section widths that correlate to your toolbar width. (Fig. 2-18)

16. Press the Next Page icon.

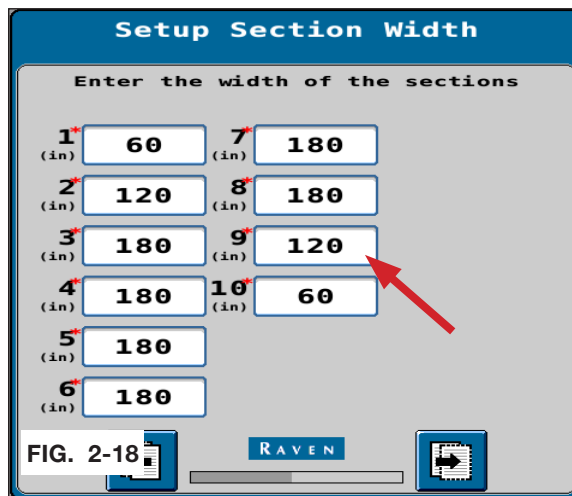

17. Ensure all the boxes are selected as “None”.

18. Press the Next Page icon.



Rate Control Module (RCM) Set Up (continued)

19. Review the information on the Section Summary screen. (Fig. 2-20)
20. If the information is correct, press the Next Page icon. To adjust the configuration, press Back and adjust settings as needed.
21. Press the Next Page icon.

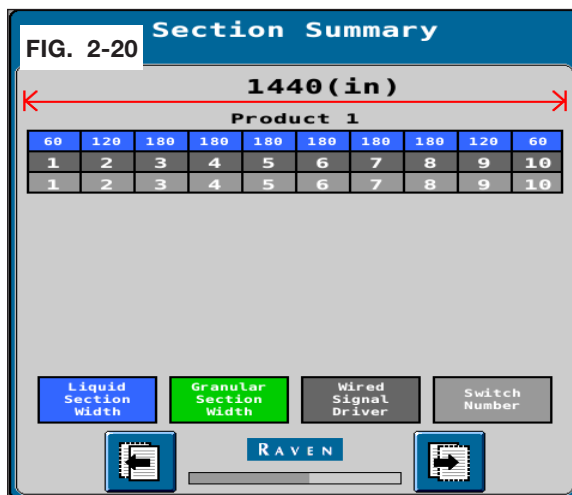

22. Under Pressure Sensor 1 select “0-250 psi (1-5V)”. Under Pressure Sensor 2 select “None”. (Fig. 2-21)
23. Press the Next Page icon.

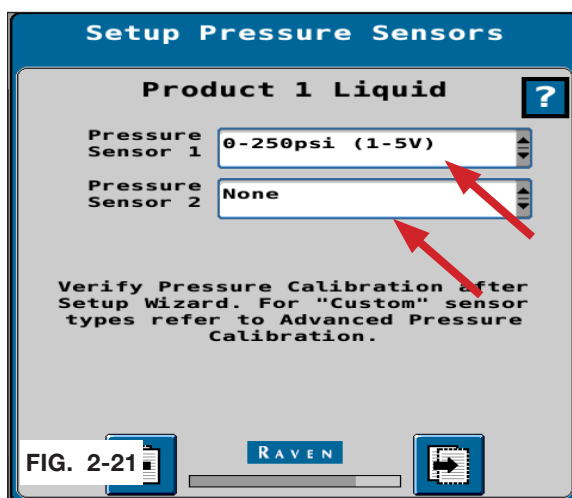

24. Under “Pressure Sensor 1”, set minimum and maximum pressures. It is recommended to start with the minimum at 15 psi.
 - 205 pump max range is 70–100 psi.
 - 750 pump max range is 100–130 psi.

This should be adjusted depending on what nozzle is being used. Check the “Alarm” box if it is desired to be notified when the pressures deviate from the min and max. (Fig. 2-22)

25. Press the Next Page Icon.

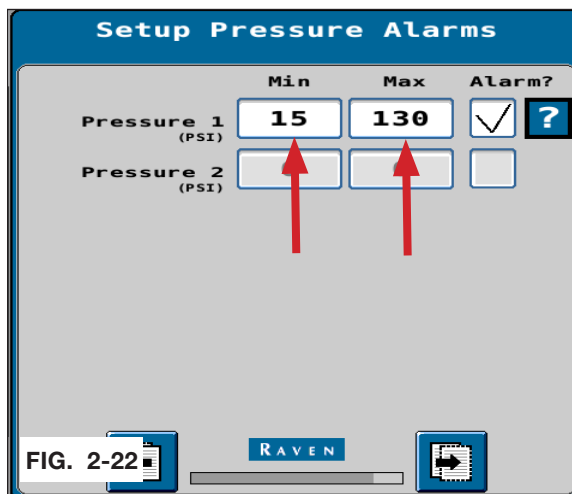

Rate Control Module (RCM) Set Up (continued)

26. Ensure both the “Agitator Installed” and the “Flow Return Installed” boxes are both unchecked. (Fig. 2-23)

27. Press the Next Page icon.

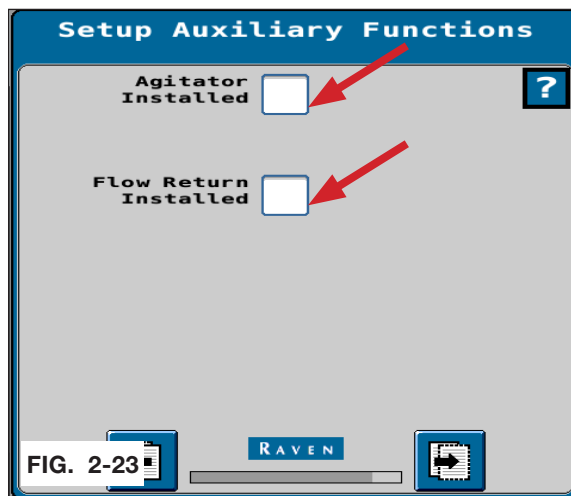

28. Select “PWM” for control valve type. (Fig. 2-24)

29. For “Valve Response Rate” enter 25.

30. For “Control Deadband %” enter 3.

31. For “Valve Delay” enter 0.

32. Ensure “Enable PWM Smart Control” box is unchecked. (Fig. 2-24)

NOTE: The pictured values are suggested starting numbers. You can fine tune these values to best fit your application. The question mark outlines what happens when adjusting each value. (Fig. 2-24)

33. Press the Next Page icon.

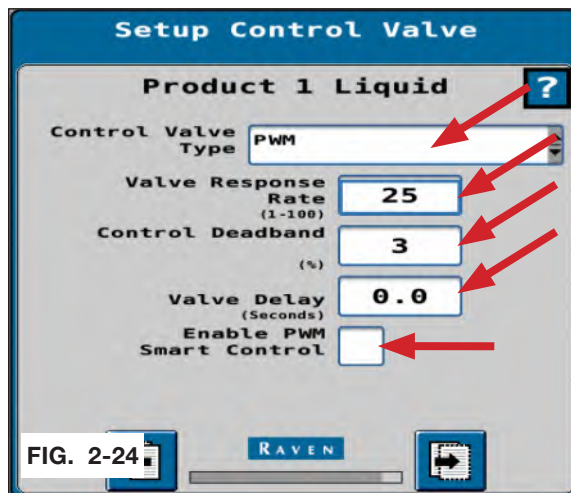

34. For the PWM valve “Coil Frequency”, ensure the value is set at 122. (Fig. 2-25)

35. Set the “PWM High Limit” at 100.

36. For “PWM Low Limit” enter 35.

37. “PWM Standby” remains at 0. (Fig. 2-25)

38. Press the Next Page icon.

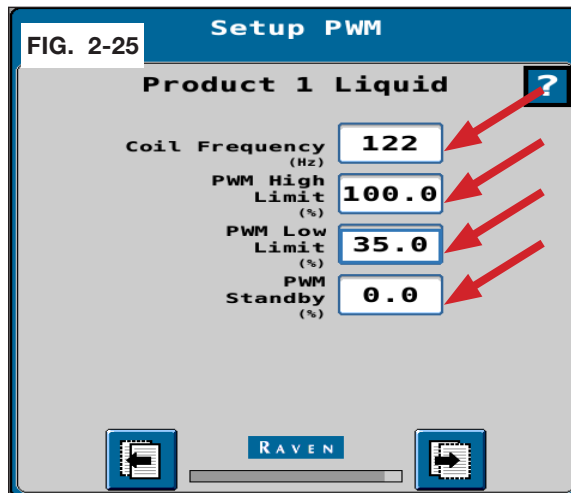

Rate Control Module (RCM) Set Up (continued)

39. Enter the “Flowmeter Calibration” number. This is unique to each Flowmeter. Check the tag on your flow meter to find the value. The value represented in the picture below does not necessarily represent the number for your Flowmeter. (Fig. 2-26)

40. Press the Next Page icon.

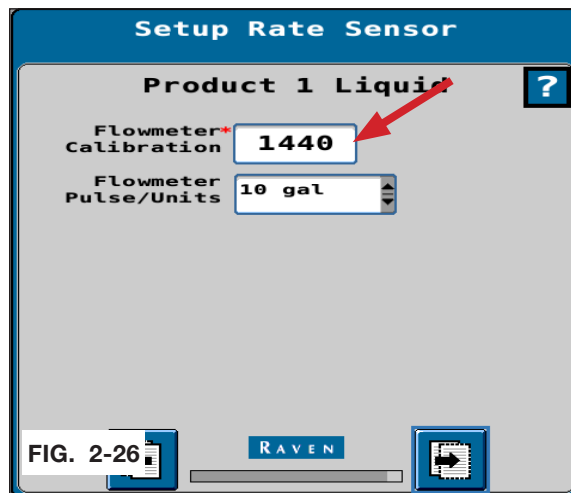

NOTE: If unit is not equipped with a tank fill monitor, select “None” from the “Tank Fill/Level Sensor” dropdown, then skip to step 49. (Fig. 2-27)

41. If unit is equipped with tank fill monitoring, select “Tank Fill Flowmeter” from the “Tank Fill/Level Sensor” dropdown”. (Fig. 2-27)

42. For “Tank Capacity” enter 2400.

43. For “Current Tank Level” enter 0.

44. For “Low Tank Level” and “Max Tank Fill PWM” ensure values are 100. (Fig. 2-27)

45. If desired, select the “Alarm” checkbox to be notified when the tank fill level falls below the low tank level threshold. (Fig. 2-27)

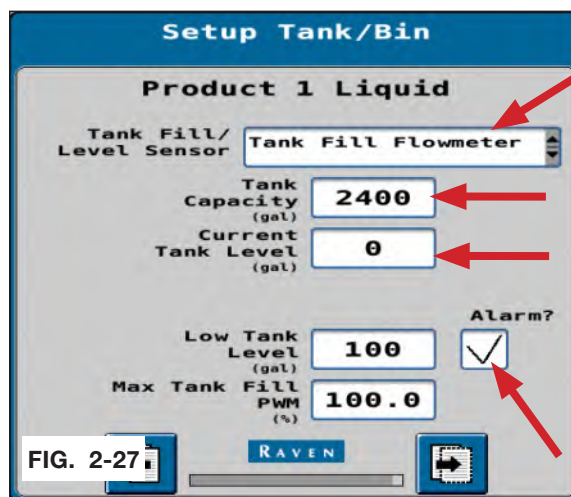

46. Press the Next Page icon.

47. Enter the “Tank Fill Flowmeter Calibration” for the flowmeter at the fill port. This is found on the tag on the wire coming from the flowmeter. The value represented in the picture below does not necessarily represent the number for your flowmeter. (Fig. 2-28)

48. Press the Next Page icon.



Rate Control Module (RCM) Set Up (continued)

49. The “Setup Rates” page determines the application rates that the RCM will regulate to. Enter any desired three “Preset Rate Values” which can be selected on the home screen. On the home screen, target rates can be entered as well. (Fig. 2-29)

50. Enter “Rate Bump” value in an increment as desired.

51. For “Rate Selection”, select “Predefined or Rx”. This enables selection of rate from the preset value choices or from a prescription map that is imported from a Universal Terminal.

52. Check “Display Smoothing”.

53. Select a “Decimal Shift” of “1”.

54. Ensure the “Standby Pressure” is left at “0” and the box is unchecked. (Fig. 2-29)

55. Press the Next Page icon.

56. For “Off Rate Alarm” enter 20 and check “Alarm” box. (Fig. 2-30)

NOTE: Alarm prompts when over 20% off target rate.

57. Press the Next Page icon.

58. No action required on this screen. This screen shows the setup summary. Make sure all the values are correct. (Fig. 2-31)

59. Press the Next Page icon to finish the RCM set-up.

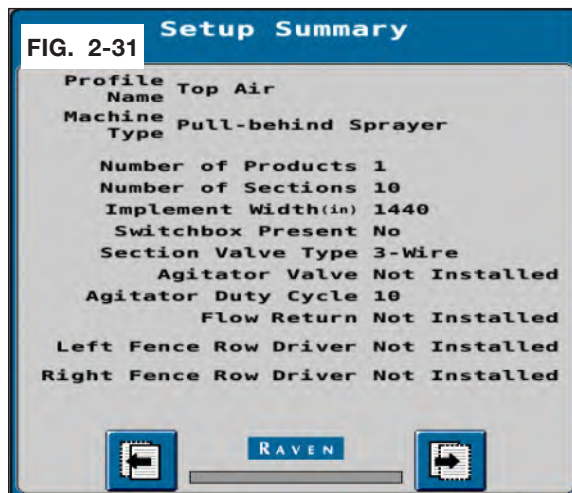
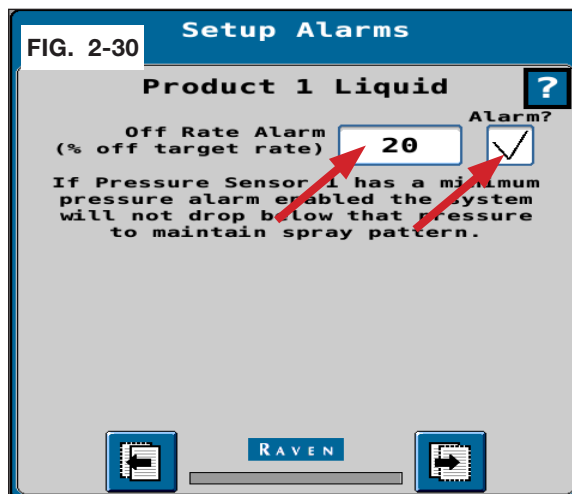
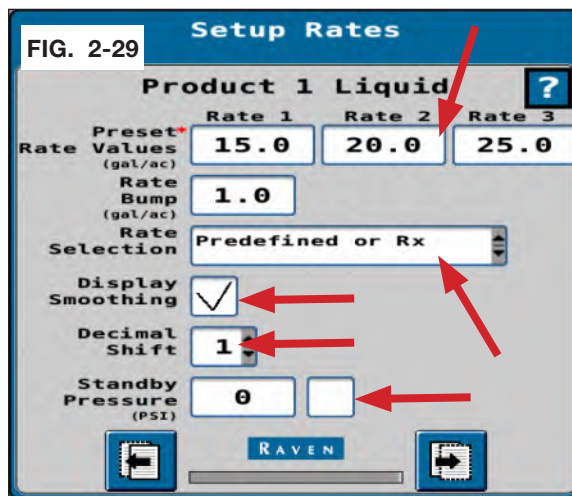

Flow Meter Calibration

Flow Meter Calibration can be accomplished by performing a catch test calibration or an Applied Product Calibration. This calibration should only be done if the applied rate differs greatly from the target rate

Catch Test Calibration

A catch test calibration will calibrate the flow meter by dispensing product through user defined sections into a container without moving the machine. The collected amount is then entered into the display to complete calibration.

1. Navigate to the settings page and select the System Settings tab.
2. Touch the Rate Sensor Setup button. (Fig. 2-32)

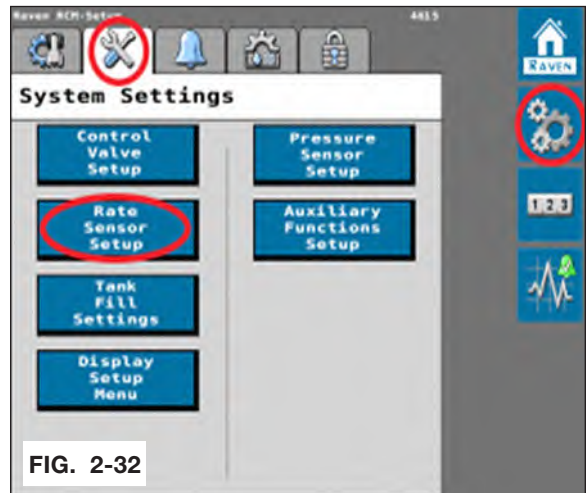

FIG. 2-32

3. Touch the Catch Test Calibration. (Fig. 2-33)

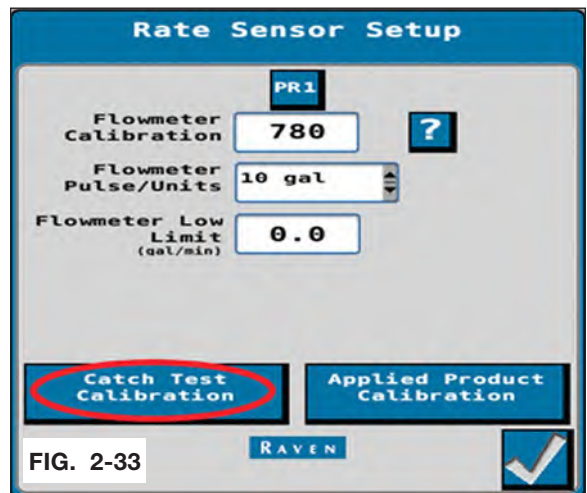
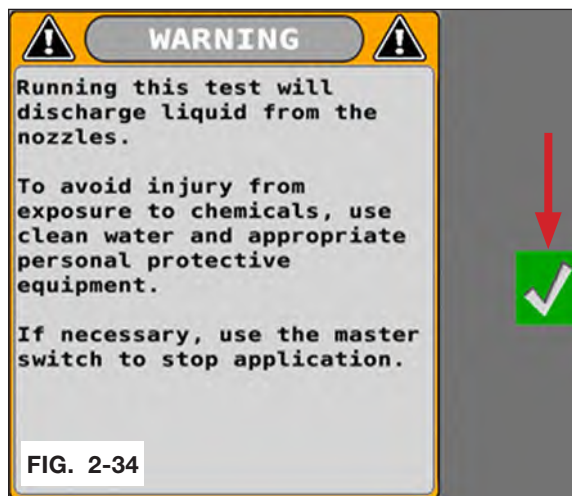

FIG. 2-33

Flow Meter Calibration (continued)

4. A warning message will be displayed. Review the message and touch the Green Checkmark. (Fig. 2-34)



5. Select which sections to dispense product through and touch Calibrate Rate Sensor. (Fig. 2-35)

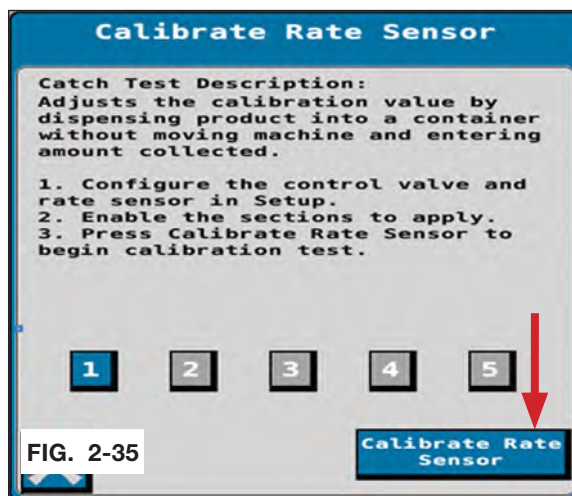

6. Enter the number of nozzles in the sections selected that will dispense product into the Number of Nozzles that will Spray. Enter a Test Speed similar to what will be used for field application. Enter the Rate that will be used for field application. Enter the Volume to Dispense per Nozzle. (Fig. 2-36)

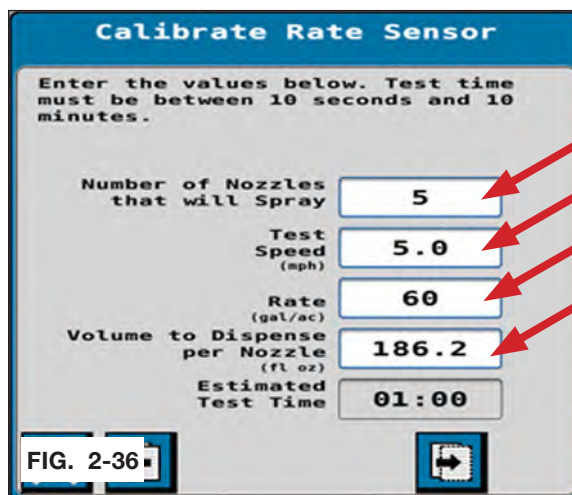

7. Touch Next Page icon.

NOTE: When choosing how much volume to dispense per nozzle, consider how large of containers you are using to collect the product. It is also important to choose an amount that will have an estimated test time between 10 seconds and 10 minutes. The more product dispensed, the more accurate the test will be.

Flow Meter Calibration (continued)

8. Turn the master switch on and then press start to begin the test. Once the test is complete, collect the product and measure how much was dispensed. (Fig. 2-37)
9. Enter the amount collected and touch the calibrate/finish button to complete calibration.

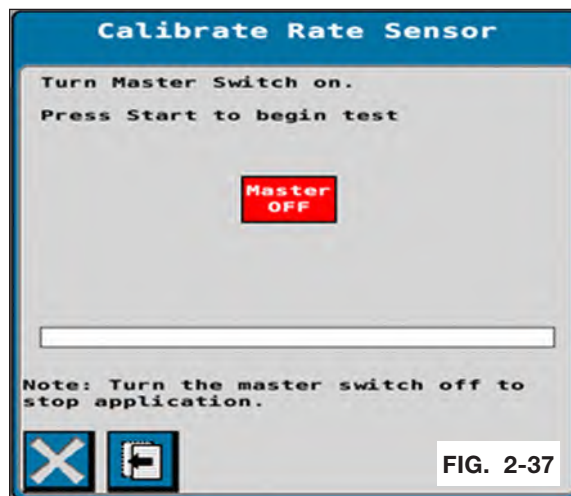

Applied Product Calibration

An applied product calibration compares the amount of product that is applied during normal field application to the amount of product the flow meter thinks was applied. This test can be used when time doesn't allow for a full catch test or if calibration of a larger quantity of product is desired.

1. Navigate to the settings page and select the System Settings tab.
2. Touch the Rate Sensor Setup button. (Fig. 2-38)

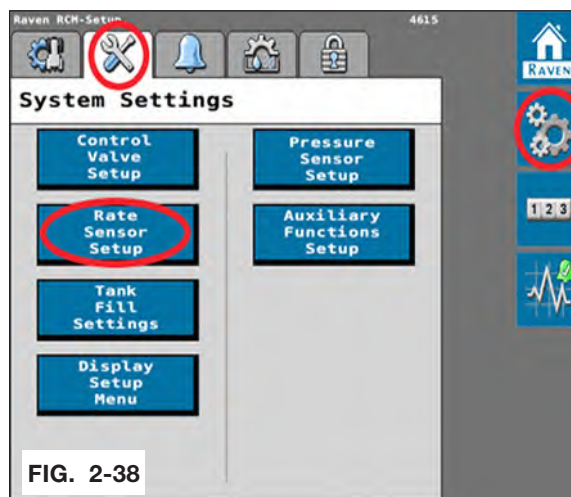

Flow Meter Calibration (continued)

3. Touch the Applied Product Calibration. (Fig. 2-39)

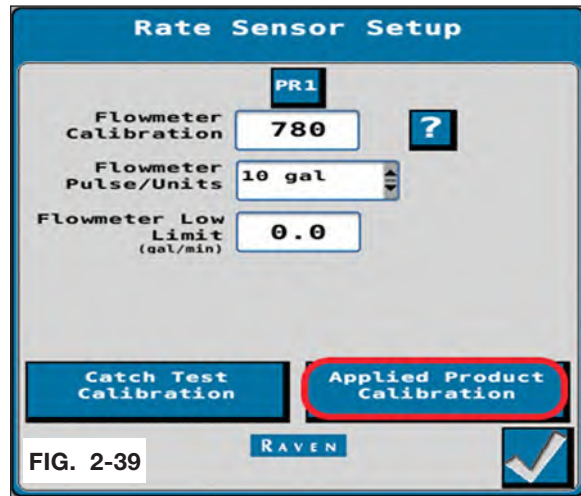

4. A message outlining the test procedure will be displayed. Review the instruction and touch the checkmark. (Fig. 2-40)

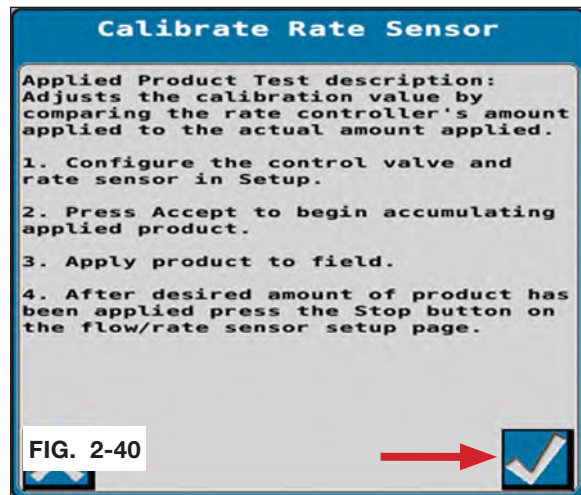

5. Ensure that the applied product is being recorded. A button should be displayed indicating the accumulated total. Once the application is complete, touch the Stop Accumulating button. (Fig. 2-41)
6. Follow the on screen steps to complete the applied product calibration.

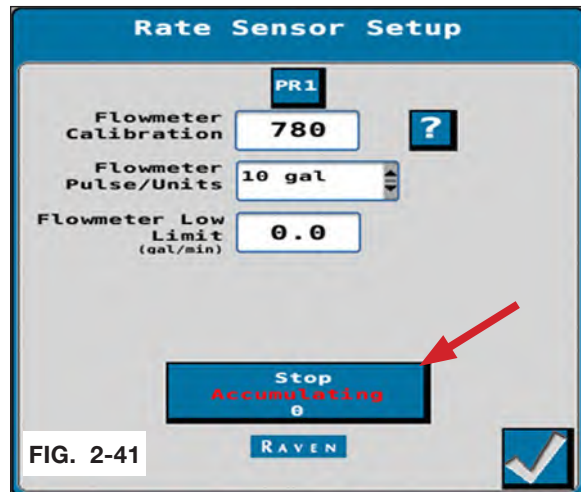

Flow Meter Calibration (continued)

Nozzle Flow Check

A nozzle flow check test allows the operator to check nozzle flow by turning on the pump and valves while remaining stationary. This could be necessary if having issues with nozzle flow.

1. Navigate to the Diagnostics page and select the Tests tab. (Fig. 2-42)

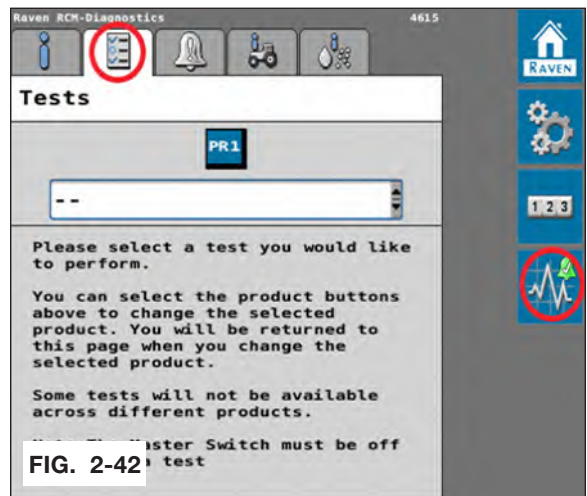

FIG. 2-42

2. Select “Nozzle Flow Check” from the drop down menu. (Fig. 2-43)

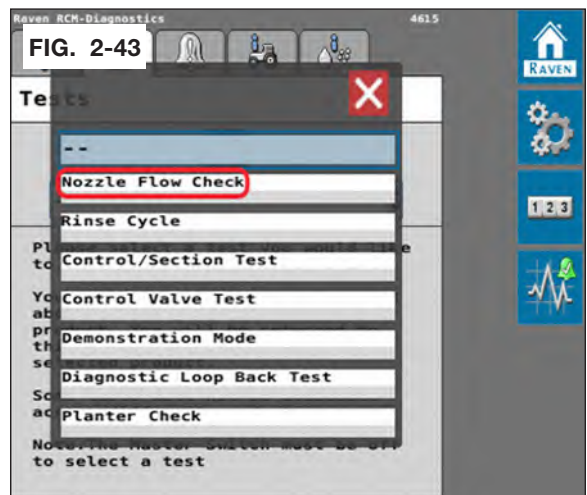
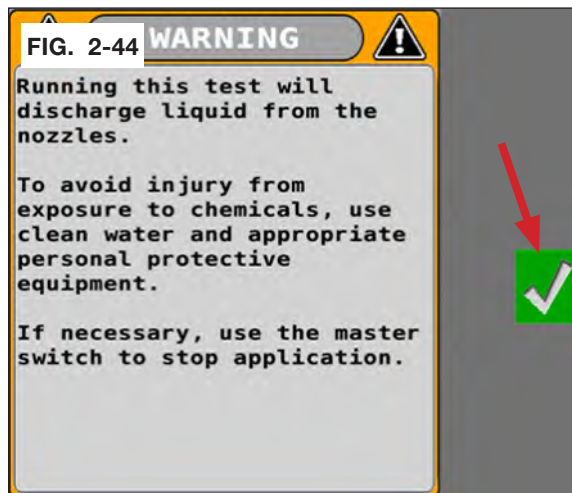

FIG. 2-43

Flow Meter Calibration (continued)

3. Press begin to start the process. A warning alarm will pop up saying that the test will discharge product. Make sure to read the warning carefully. Touch the green checkmark. (Fig. 2-44)



4. Review the step by step instructions. Touch Start to initiate product flow. Complete system inspection as necessary. (Fig. 2-45)

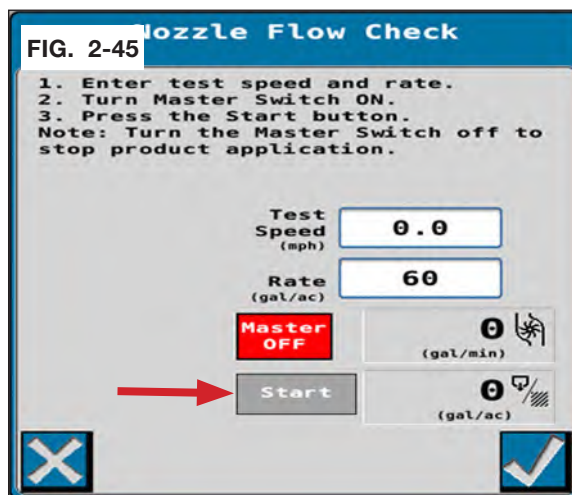

Control Section Test

A Control Section Test is used to manually operate each section shut off valves. This test can be used when diagnosing issues with the section control system.

1. Navigate to the Diagnostics page and select the Tests tab. (Fig. 2-46)

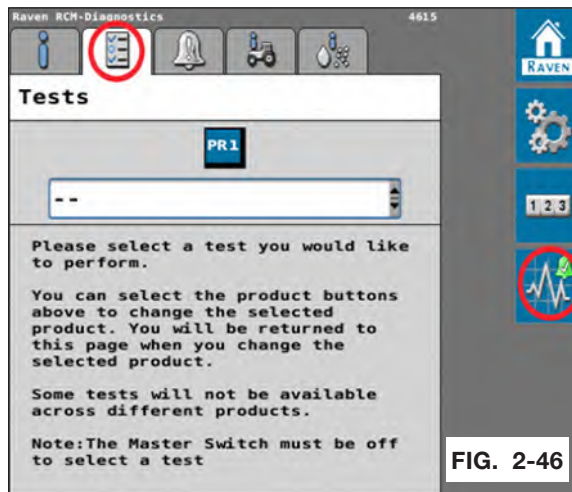
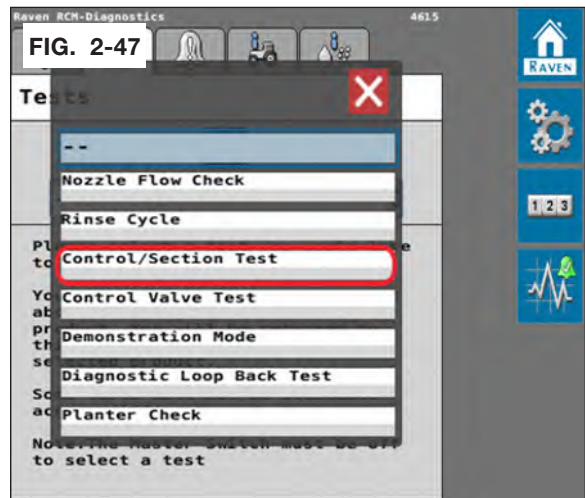

FIG. 2-46

Flow Meter Calibration (continued)

2. Select “Control/Section Test” from the drop down menu. (Fig. 2-47)



3. Press begin to start the process. A warning alarm will pop up saying that the test will discharge product. Make sure to read the warning carefully. Touch the green checkmark. (Fig. 2-48)

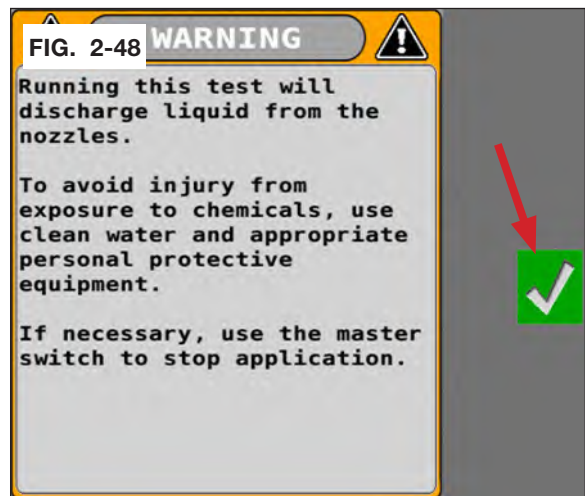

4. Review the step by step instructions and then press start. Each section can be toggled on and off by touching the corresponding section button. (Fig. 2-49)

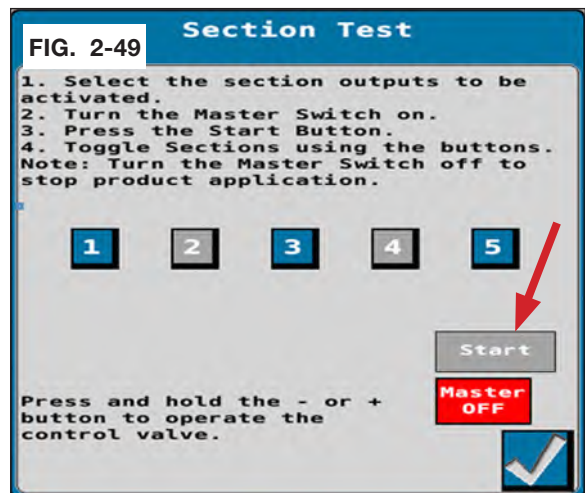

Control Box

Using Switch Box to Operate Steerable Hitch

1. To calibrate follow all instructions provided in your Raven steerable hitch manual.
2. Boom must be unfolded for hitch to operate. A proximity switch located on the boom disables the unit when boom is folded and in transport position. This will be displayed on the Raven console as “prox”.
3. After the steerable hitch is calibrated, the Top Air switch box will become the master and the Raven console will become the slave.
4. **ON / OFF Switch:** This switch must be in the “ON” position for the hitch to operate. When the hitch is centered by engaging the Transport function, the ON / OFF switch must be cycled by switching to “OFF” then back to “ON” again.
5. **AUTO / TRANSPORT:** By tapping the switch up to the “AUTO” mode, the hitch will automatically follow the tractor. The Raven console will display “AUTO”. When the switch is tapped to “TRANSPORT”, the hitch will center. The Raven console will display “CENTER”. When the transport function is engaged, the ON / OFF switch must be cycled by switching to “OFF” then back to “ON” again to return to “AUTO”.
6. **MANUAL:** This switch allows for “MANUAL” steering left or right. Each time the switch is tapped (pushed and released, it is not necessary to hold the switch) the hitch moves a pre set # of degrees to the right or left depending on the direction the switch is moved. The amount the hitch moves when using the “MANUAL” switch is pre-set to 5 degrees. The pre-set can be changed by referring to the steerable hitch manual. After the “MANUAL” steer is engaged, the Raven console will display “BUMP”. To return to “AUTO” operation you will need to tap the “AUTO / TRANSPORT” switch up to “AUTO”.

Command Center 4 System Set Up

Procedure for Linking Radio and Receiver

NOTE: Do the following steps to teach the address to the receiver without using the Pocket PC.

1. Apply power to both transmitter and receiver.
2. Activate the toggle switch on transmitter that corresponds to RH tilt up.
3. With the toggle switch on transmitter still activated, push and release the Address Learn Button on the receiver, then release switch on the transmitter.
4. When the green RF Signal LED on the receiver flashes, the receiver has learned the address.
5. Activate any toggle switch on the transmitter and verify that the RF Signal LED on the receiver is still flashing green. This indicates that communication has been established between the two units.



FIG. 2-50

Hydraulic Manifold Set Up

Set Up for Power Beyond Connection

The hydraulic manifold is configured from the factory to be compatible with connection to standard tractor hydraulic control (SCV) circuits. To convert for use with power-beyond circuits of load-sensing closed-center hydraulic systems, use kit number 402406 and the following procedure:

IMPORTANT

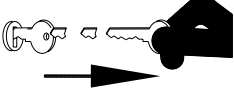
- *Tractor must be equipped with a load-sense port.*
1. Park empty unit on a firm, level surface. Block the machine to keep it from moving. Set vehicle's parking brake, shut off the engine, and remove the ignition key.
 2. Relieve all hydraulic system pressure.
 3. Unscrew retaining nut at end of 2-way cartridge valve and remove electric coil.
 4. Remove 2-way cartridge valve by unscrewing valve from manifold.
 5. Install "normally-closed" valve in manifold (Identified by WS08Z stamped on valve).
 6. Reinstall electric coil and hand-tighten supplied plastic knob to secure.
 7. Remove short hose from LS port and tee fitting.
 8. Install cap on open end of tee fitting.
 9. Unscrew fittings from LS port on manifold.
 10. Remove existing hollow hex plug in bottom of LS port cavity.
 11. Using a hex wrench, install orifice plug in bottom of LS port cavity. Reinstall fittings on LS port.
 12. Install high-pressure hose from LS port to tractor load-sense port.

Hydraulic Manifold Set Up (continued)

Closed-Center Conversion Kit

The closed-center conversion kit 406107 needs to be installed for pressure-compensating closed-center tractors. Load-sense closed-center tractors do not need this kit.

1. Park empty unit on a firm, level surface. Block the machine to keep it from moving. Set vehicle's parking brake, shut off the engine, and remove the ignition key.

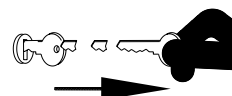

2. Relieve all hydraulic system pressure.
3. Unscrew retaining nut at end of 2-way cartridge valve and remove electric coil.
4. Remove 2-way cartridge valve by unscrewing valve from manifold.
5. Install supplied cavity plug in manifold.
6. Remove pressure hose from P port.
7. Install supplied orifice in P port.
8. Reinstall pressure hose on end of orifice installed in previous step.

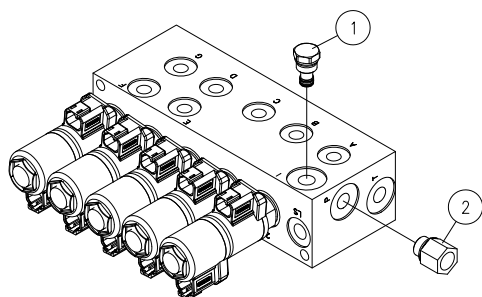

FIG. 2-51

CLOSED CENTER CONVERSION			
ITEM	DESCRIPTION	PART NO.	QTY.
	Kit Includes:	406107	1
1	Cavity Plug	9006486	1
2	Port Reducer O-Ring Orifice	9006531	1

Setting the Pump Pressure - PWM

IMPORTANT

- *Water must be in the solution tank. Refer to “Filling the Tank” in the OPERATION section.*
- *Booms should be unfolded when setting the pump pressure. Refer to unfolding booms section of the MAINTENANCE section.*
- *The pump inlet selector should be pointed to solution tank. The pump outlet selector should be pointed to boom.*

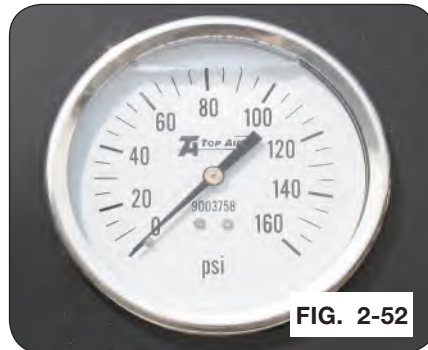

1. Rate controller must be calibrated.
2. Select manual control on the console and turn the master switch on. Press and hold the Inc. button for 5 seconds to verify cartridge valve is fully open, ensuring the system reaches 100% duty cycle.
3. Turn off section valves, agitation valve and filter purge valve.
4. Turn the SCV hydraulic flow to 50%. The cartridge valve is sized to not allow more than 11GPM to the pump.
5. Increase the hydraulic flow until the filter inlet or pump pressure is:
 - 100–110 PSI for 205 / 304 PWM pump
 - 130–140 PSI for 750 PWM pump
6. Open the agitation to 25 PSI on the agitation gauge.
7. Open the filter purge valve until you can hear fluid run over the filter screen.

Setting the Pump Pressure - Non-PWM

IMPORTANT

- *Water must be in the solution tank. Refer to “Filling the Tank” in the OPERATION section.*
- *Booms should be unfolded when setting the pump pressure. Refer to unfolding booms section of the MAINTENANCE section.*
- *The pump inlet selector should be pointed to solution tank. The pump outlet selector should be pointed to boom.*



FIG. 2-53

1. Adjust circuit flow to minimum setting prior to operating for the first time.
2. Hold the agitation button located on the Command Center to close so the agitation is completely closed.
3. Close the filter purge valve.
4. Engage hydraulic lever to RETRACT position.
5. Increase the flow in the tractor until the filter inlet or pump pressure is:
 - 100–110 PSI for 206 ACE pump
6. Open the agitation to 25 PSI on the agitation gauge.
7. Open the filter purge valve until you can hear fluid run over the filter screen.

Sprayer Calibration

Determine Required Nozzle Size

Use the following procedure to assist with sizing the spray nozzle and calibrating the sprayer. Additional information can be found in the spray controller owner's manual and also obtained from spray nozzle manufacturers.

The following procedure assumes that an electronic spray rate controller is being used.

1. Decide the typical operating speed (in MPH) and coverage rate (in GPA) that will be used.
2. Calculate nozzle flow:

$$\text{Nozzle GPM} = \frac{\text{MPH} \times \text{GPA} \times \text{Nozzle Spacing} \times \text{DCF}^*}{5940}$$

*DCF = Density Conversion Factor

Weight of Solution	Specific Gravity	Density Conversion Factor (DCF)
8.34 lb./gal. (Water)	1.00	1.00
10.65 lb./gal. (28% Nitrogen)	1.28	1.13

Example:

Speed = 8 miles per hour
 Rate = 10 gallons per acre
 Nozzle Spacing = 20 inches
 Liquid = Water

$$\text{Nozzle GPM} = \frac{\text{MPH} \times \text{GPA} \times \text{Nozzle Spacing} \times \text{DCF}^*}{5940} = 0.27 \text{ GPM}$$

3. Go to the Top Air Tip Catalog to select a tip.

Choose a nozzle that will provide the calculated GPM within the nozzle's operating pressure range. Typically, 2 or 3 nozzle sizes will be found that meet the calculated GPM. However, it is usually a good practice to choose a flow size that lists this GPM in the mid-portion of the nozzle's advertised ratings.

4. Choose a type of tip for the given application. Ex. XRC, AIC.
5. Determine a spraying pressure required for the chemical being used.
6. Match up the spraying pressure needed in column 2 and the gpm calculated in column 3. This determines the color of tip required.

Electric Command Center Installation

1. Pull down wires located behind the command center on the frame rail. (FIG. 2-54)
2. Remove black cover. (FIG. 2-55 & 2-56)
3. Remove hose from bottom of outlet selector. (FIG. 2-57)
4. Remove clamp from top side of outlet selector. (FIG. 2-57)
5. Remove clamp from back side of outlet selector. (FIG. 2-57)
6. Remove outlet selector. (FIG. 2-58)
7. Attach electric valve (9003955). (FIG. 2-59)

IMPORTANT

- *Note the orientation.*
8. Finish attaching electric valve.
 9. Attach 3-pin weather pack from electric valve to the 3-pin weather pack with the pink and white wire to the sprayer.
 10. Remove the 3" quick fill.
 11. Remove the front panel. (FIG. 2-60)
 12. Remove black cover. (FIG. 2-61)

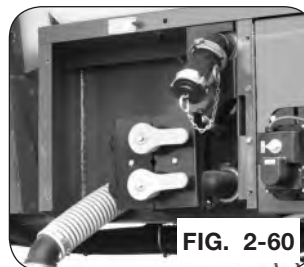
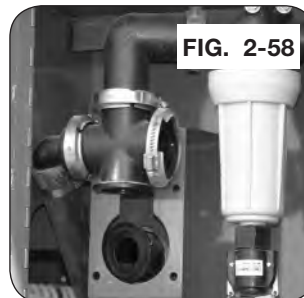
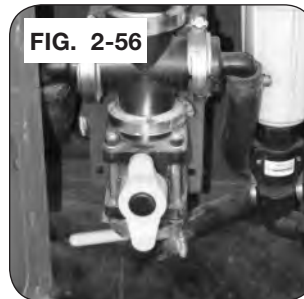

Electric Command Center Installation (continued)

13. Remove all fittings connected to the two ball valves. (FIG. 2-62)

IMPORTANT

- Note the position of the fittings.
14. Separate the two ball valves, by removing the clamp. (FIG. 2-63)

15. Slide the two ball valves off the mounting plate, while keeping the top ball valve. (FIG. 2-63)

16. Slide the electric ball (9003956) valve into position first. (FIG. 2-64)

17. Slide the top ball valve back into place. (FIG. 2-64)

18. Attach fittings to electric and top ball valves into the same position. (FIG. 2-65)

19. Plug wire from electric ball valve into the 3-pin weather pack with the orange wire on the sprayer. (FIG. 2-65)

20. Remove the cam-lock fitting from the bottom of the filter. (FIG. 2-66)

21. Remove the hose from the tank.

22. Attach elbows, using the clamps, to the electric ball valve (9003957). (FIG. 2-67)

23. Mount the electric ball valve in the pre-drilled holes on the underside of the sprayer, use the u-bolts to secure. (FIG. 2-68)

24. Thread the elbow into the cam-lock fitting.

25. Attach the hose to the elbow.

26. Attach the cam-lock fitting to the bottom of the filter. (FIG. 2-69)

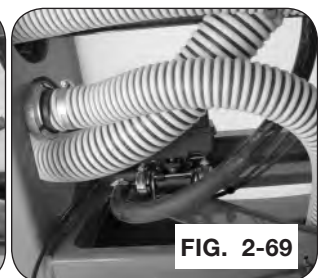
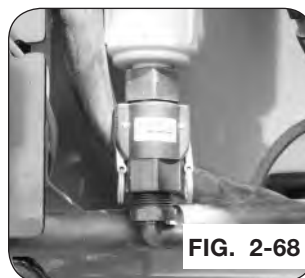
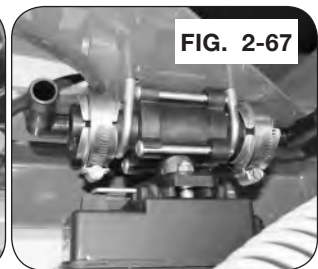
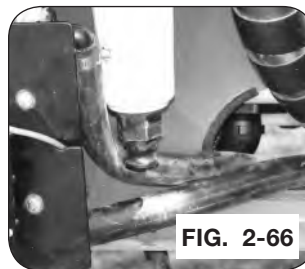
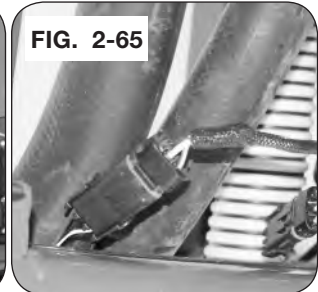
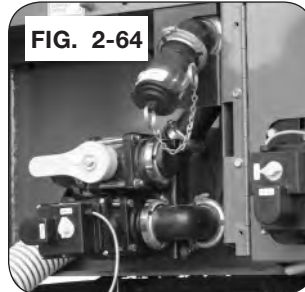
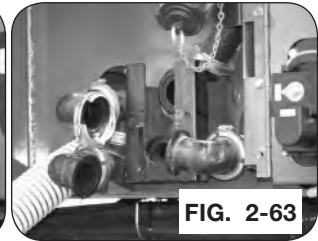
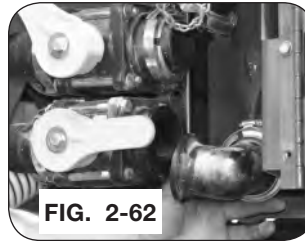

Electric Command Center Installation (continued)

27. Route the hose to the electric ball valve and cut to length and attach to electric ball valve. (FIG. 2-70)
28. Attach remaining hose to other end of electric ball valve.
29. Route hose to the tank fitting, cut to length and attach the hose.
30. Plug in two-pin weather pack from the electric ball valve to the 2-pin weather pack from the sprayer. (FIG. 2-71)
31. Route the 4 wires up to the switches.
32. Attach wire to the switch, note the orientation.
33. Insert switch into hole, secure nut and attach rubber end, reattach front panel. (FIG. 2-72)

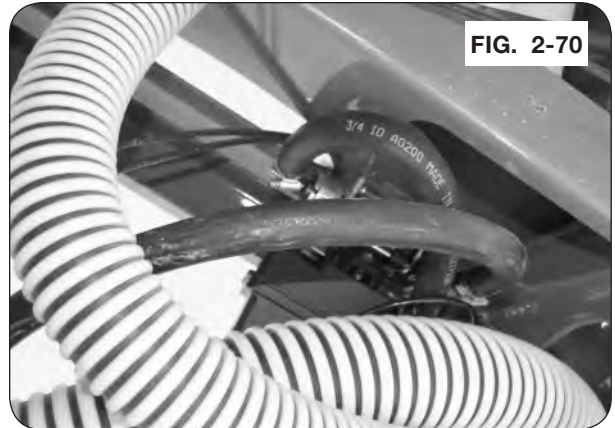

FIG. 2-70

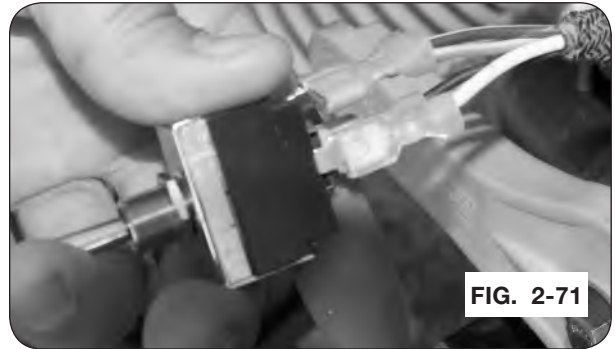

FIG. 2-71



FIG. 2-72

XRT Autoboom Height Control

Refer to Raven Auto-Height Installation Manual.

Steerable Hitch

Refer to Raven Auto-Steer Hitch Installation Manual.

Section III Operation

Operating Checklist.....	3-2
Preparing Tractor.....	3-3
Preparing Sprayer.....	3-3
Hitching to Tractor.....	3-5
Drawbar Hitching.....	3-5
Jack Usage.....	3-6
Transport Chain.....	3-7
Hydraulic Connections.....	3-8
Electrical Connections.....	3-10
Transporting.....	3-11
Drawbar Connection.....	3-11
Boom Operation.....	3-12
Unfolding.....	3-12
Folding.....	3-13
Electric Recirculating Valve Operation.....	3-14
Manual Override for Electric Recirculating Valve.....	3-15
Filling Sprayer.....	3-16
Quick Fill.....	3-16
Tank Mixing.....	3-16
Rinsing Sprayer.....	3-17
Solution Tank.....	3-17
Boom Only Tank.....	3-17
Foam Marker.....	3-18
Filling.....	3-18
Foam Collector Height.....	3-18
Basic Operation.....	3-18
Chemical Inductor.....	3-19
Basic Operation.....	3-19
Chemical Container and Inductor Tank Rinsing.....	3-20
Electric Command Center.....	3-21
Filter Purge Controls.....	3-21
Pump Inlet/Outlet Controls.....	3-21
Fence Row Nozzle.....	3-22
XRT Autoboom Height Control.....	3-22
Steerable Hitch.....	3-22
Hydraulic Instructions.....	3-23
HYPRO Pump.....	3-23

Operating Checklist

- Read and understand all safety precautions before operating sprayer.
- Torque wheel nuts as specified in MAINTENANCE section.
- Verify track has been aligned and is properly conditioned. Refer to Equalizer® Track sprayer manual MAINTENANCE section for alignment information. (If applicable)
- Check tire pressure and inflate tires as needed to specified air pressure. See “Tire Pressure” in MAINTENANCE section. (if applicable)
- Verify and/or adjust the sprayer hitch height before coupling to tractor. The sprayer hitch is adjusted by unbolting the hitch and reinstalling in a different set of holes. See “Hitching to Tractor - Drawbar Hitching” in this section.
- Verify tractor drawbar height and length. See “Preparing Tractor” in this section.
- Lubricate all grease fittings. Refer to “Lubrication” in MAINTENANCE for additional information.
- Verify all safety decals are correctly located and legible. Replace if damaged.
- Verify all reflective decals are correctly located.
- Check SMV emblem and SIS decals are in place, clean and visible.
- Ensure ladder is in storage position.
- Ensure transport chain is installed and properly secured. See “Transport Chain Connection” in this section.
- Check hydraulic components for leaks and check hose routing.
- Check all plumbing components for leaks.

Preparing Tractor

- Before operating sprayer, read the tractor Operator's Manual and gain an understanding of its safe methods of operation.
- Check the tractor brakes and lights. Make sure they are in proper working order.
- Check the tractor hydraulic oil reservoir and add oil if needed.
- Read the tractor Operator's Manual for information on tractor drawbar length.
- Verify that the tractor is adequately ballasted for drawbar operation at the anticipated draft and vertical tongue load. Vertical tongue load of loaded sprayer (with booms folded to transport position) is approximately 5,000 lbs. Ensure the tractor's drawbar has sufficient strength to support this load.
- If possible, adjust the tractor drawbar vertically so the top side of the drawbar is at least 18 inches from the ground. Alternately, the sprayer hitch may be adjusted vertically by choosing other mounting holes provided.
- On sprayers equipped with a drawbar-style hitch, raise and secure all tractor 3-point hitch linkage to prevent interference with the implement tongue and hydraulic hoses during turning.

Preparing Sprayer

Perform the service checks as outlined below. Repair or replace any damaged or worn parts before operating.

Hardware

Check for loose bolts and nuts, and tighten as needed. Check again after the first half-day of operation.

Pivot Pins

Check that all pins are in place and in good condition. Replace any worn, damaged or missing pins.

Hitch

Check hitch wear plates for damage and wear. Be aware of the size of hitch adapter bushing that is being used. Select correct size for the hitch pin/draw bar you are using.

Hydraulic System

Check all hoses and cylinders for signs of leakage. Hoses should not be kinked, twisted or rubbing against sharp edges. Re-route or repair hoses as necessary. Refer to SAFETY section for additional information on safe repair and inspection of hydraulic components.

(Continued on next page)

Preparing Sprayer (continued)

Tires/Wheels

Check tire pressures and maintain at recommended values listed in the MAINTENANCE section of this manual.



CAUTION

- **IMPROPERLY TORQUED WHEEL NUTS/BOLTS CAN CAUSE A LOSS OF IMPLEMENT CONTROL AND MACHINE DAMAGE. WHEEL NUTS/BOLTS MUST BE CHECKED REGULARLY. SEE TORQUE PAGE IN THE MAINTENANCE SECTION FOR PROPER WHEEL NUT/BOLT SPECIFICATIONS. WARRANTY DOES NOT COVER FAILURES CAUSED BY IMPROPERLY TORQUED WHEEL NUTS/BOLTS.**
-

IMPORTANT

- *Installing wheels without the proper inset/offset could result in hub or spindle failure. This will cause substantial damage to the sprayer and is not covered by warranty. Inset/offset will vary depending on tire size. Consult dealer for proper inset/offset.*

For questions regarding new tire warranty, please contact your local original equipment tire dealer. Used tires carry no warranty. Tire manufacturers' phone numbers and web sites are listed in the MAINTENANCE section of this manual for your convenience.

Lubrication

Lubricate the sprayer as outlined in the MAINTENANCE section of this manual.

Hitching to Tractor

Drawbar Hitching

WARNING

- **CRUSHING CAN CAUSE SERIOUS INJURY OR DEATH. DO NOT STAND BETWEEN TOWING VEHICLE AND IMPLEMENT WHEN HITCHING. ALWAYS ENGAGE PARKING BRAKE AND STOP ENGINE BEFORE INSERTING HITCH PIN.**

Connect the drawbar hitch only to the tractor drawbar. Do not attempt to hitch to any other location on the tractor.

Single Tang

- The sprayer is equipped standard with a single tang hitch which requires a 2" diameter drawbar pin. (FIG. 3-1)

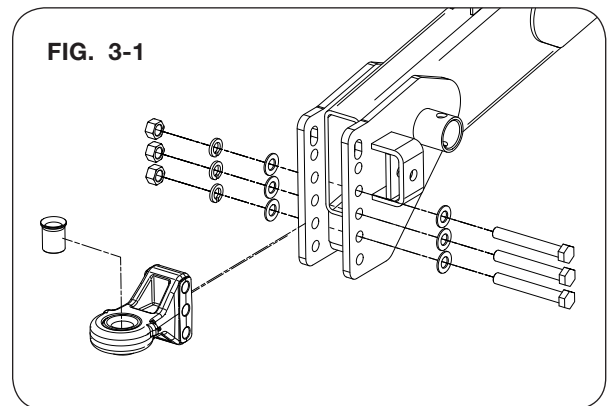

IMPORTANT

- *The use of a smaller-diameter hitch pin will result in additional clearance between the implement hitch and pin. This additional clearance may cause accelerated pin and hitch wear, along with more pronounced jolting from the sprayer during operation.*
- *Verify and/or adjust the sprayer hitch height before coupling to the tractor. The sprayer hitch is adjusted by unbolting the hitch and reinstalling in a different set of holes provided.*
- *The sprayer must be relatively level in order for the tank volume indicator to read accurately.*
- *After inserting drawbar pin, secure with a locking device to help prevent uncoupling during use.*

Hitching to Tractor (continued)

Jack Usage

⚠ WARNING

- **UNHITCHING A LOADED SPRAYER CAN CAUSE SERIOUS INJURY OR DEATH DUE TO TONGUE RISING OR FALLING. ALWAYS HAVE A LOADED SPRAYER ATTACHED TO A TRACTOR. THE JACK IS INTENDED TO SUPPORT AN EMPTY SPRAYER ONLY.**

IMPORTANT

- *Mount jack in storage location indicated after sprayer is hitched to tractor. (FIG. 3-3)*

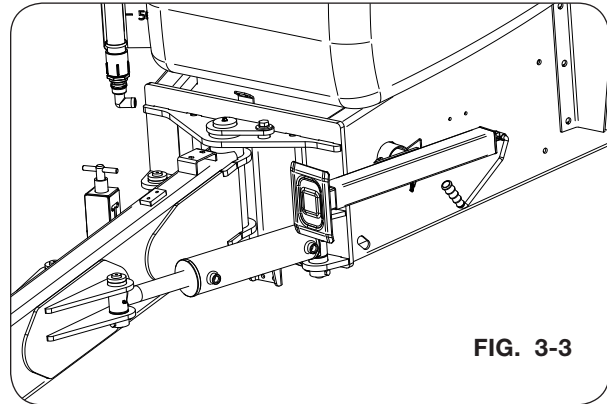
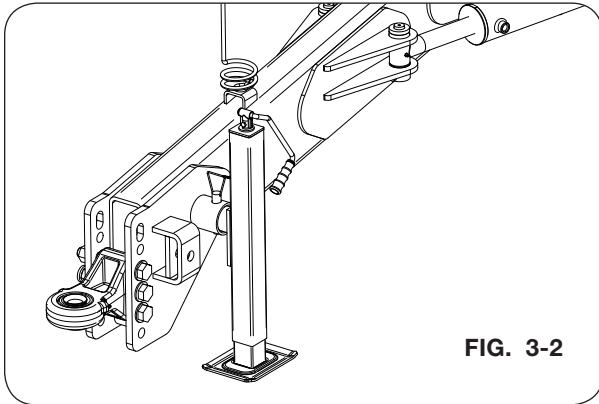

Hitching to Tractor (continued)

Transport Chain

CAUTION

- ALWAYS USE TRANSPORT CHAIN WHEN TRANSPORTING IMPLEMENTS. FAILURE TO USE A TRANSPORT CHAIN COULD CAUSE PERSONAL INJURY IF SPREADER BECOMES DISENGAGED.
- REPLACE TRANSPORT CHAIN IF ANY LINK OR END FITTING IS BROKEN, STRETCHED OR DAMAGED. DO NOT WELD TRANSPORT CHAIN.
- USE ONLY AN UNVERFERTH ASABE TRANSPORT CHAIN WITH A WEIGHT RATING EXCEEDING THE GROSS COMBINED WEIGHT OF ALL TOWED IMPLEMENTS. CONTACT YOUR UNVERFERTH DEALER FOR ADDITIONAL INFORMATION.

Tractor must be equipped with an intermediate transport chain support. Always use intermediate support when connecting sprayer directly to a tractor. DO NOT use the intermediate chain support as the chain attaching point. See tractor Operator's Manual for proper chain attachment. Figure 3-4 shows how the transport chain must be installed between implement and towing vehicle.

Transport chain connection shown for illustration purposes only. Refer to tractor manufacturer for proper attachment.



FIG. 3-4

Hitching to Tractor (continued)

Hydraulic Connections

After cleaning hydraulic hose couplers, connect to tractor hydraulic circuits as follows:

Sprayer Pump Hydraulics

IMPORTANT

- *The sprayer pump is hydraulically driven, and needs to be configured correctly to match the type of hydraulic system on the tractor (closed center, open center, load-sensing, etc.). Failure to configure the pump correctly may permanently damage the pump through over-speeding or back pressure failure. Refer to the SET UP section of this manual for guidelines on configuring the sprayer pump.*

Connect hoses from the sprayer pump to a tractor selective control valve (SCV) circuit. The pump inlet, marked BLUE (+), should be connected to the RETRACT port and the pump outlet, marked BLUE (-), to a low-pressure return port at the tractor (recommended) or to the EXTEND port. If connected to the EXTEND port, it is recommended to shut the pump down in float to preserve pump life. (FIG. 3-5)

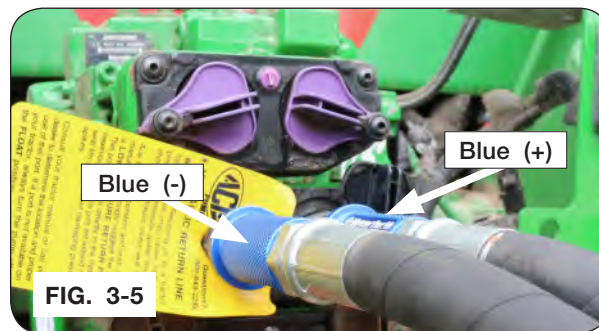

NOTE: It is recommended to pressurize all hydraulic circuits using the retract outlets on the SCVs. This allows all circuits to be shut-off by engaging the hydraulic float feature of the tractor hydraulic system.

To protect the sprayer pump from damage due to excessive speed, adjust circuit flow to minimum setting prior to operating circuit for the first time. When in operation, adjust flow per instructions listed under the “Boom Functions - Setting Flow” heading in SET UP section.

IMPORTANT

- *Never operate sprayer pump dry, or with pump inlet selector valve closed. Pump damage may result.*

Boom Hydraulics

CAUTION

- **DO NOT UNFOLD OR FOLD BOOM WITHOUT HITCHING TO THE TRACTOR.**

The wing-fold hydraulic system on this sprayer is configured to connect to a tractor SCV valve, but can also be modified to operate with power beyond circuits of tractors with a load-sensing hydraulic system (Refer to the MAINTENANCE section for information on converting to a power-beyond circuit).

Hitching to Tractor (continued)

Boom Hydraulics (continued)

WARNING

- **ACCUMULATORS USED IN THIS HYDRAULIC SYSTEM CAN RETAIN FLUID UNDER PRESSURE EVEN AFTER TRACTOR HYDRAULIC VALVE IS PLACED IN FLOAT. REMOVE RESIDUAL PRESSURE FROM WING TILT AND MAIN LIFT ACCUMULATORS BY HOLDING WING TILT AND MAIN LIFT SWITCHES IN DOWN POSITION FOR AT LEAST 20 SECONDS AFTER CYLINDERS HAVE STOPPED MOVING.**
- **AFTER INITIAL SET-UP OR REPLACEMENT OF ANY HYDRAULIC COMPONENT ON THE SPRAYER, AIR MUST BE REMOVED FROM THE WING-FOLD HYDRAULIC SYSTEM PRIOR TO ITS FIRST USE. FAILURE TO DO SO MAY RESULT IN DAMAGE TO BOOM COMPONENTS DUE TO RAPID MOVEMENT.**

IMPORTANT

- *If the SCV control lever kicks out prior to actuating any switch on the boom control box, the most likely reason is excessive hydraulic pressure. Try reducing the tractor's flow control setting. Excessive pressure can also occur if the hydraulic valve has been modified for use with power beyond systems. In this instance, attach to the three power beyond couplers on the tractor, or change the hydraulic valve attach to the three power beyond couplers on the tractor, or change the hydraulic valve setup for use with an SCV circuit.*

Connect the hose marked BLUE (+) to the RETRACT port of one of the tractor SCV circuits, and the hose marked BLUE (-) to the EXTEND port of the same circuit.

NOTE: It is recommended to pressurize all hydraulic circuits using the retract outlets on the SCVs. This allows all circuits to be shut-off by engaging the hydraulic float feature of the tractor hydraulic system.

Refer to the MAINTENANCE section for valve setup information.

Before disconnecting hoses from the tractor, place tractor in park and apply parking brake. See tractor's operators manual for proper procedure to relieve pressure. After SCV pressures have been relieved and tractor engine is off, disconnect hoses from tractor. Install couplers into storage slots provided. (FIG. 3-6)



Hitching to Tractor (continued)

Electrical Connection

The main harness has a 7-pin (round) plug conforming to SAE standards that connects to tractor. If your tractor does not have the mating socket connector, an SAE J-560 seven-point socket can be purchased from your Unverferth dealer (part number 92824) (FIG. 3-7)

The wiring schematic for this sprayer as shown in the MAINTENANCE section complies with current ASABE standards. Always verify correct electrical function before using this sprayer.

Compliance with all lighting and marking laws is the responsibility of the operator at the time of travel.

See federal regulation 49 CFR 562; available at www.govinfo.gov for US federal law requirements.

See your Unverferth dealer for additional brackets, reflectors, or lights to meet your requirements.

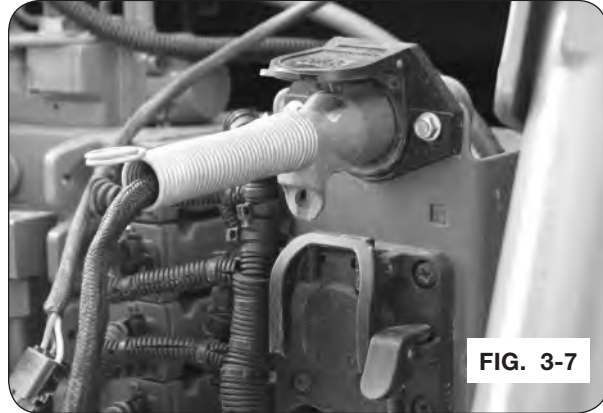

Transporting

Drawbar Connection

WARNING

- USE EXCEPTIONAL CARE WHEN OPERATING SPRAYER EQUIPPED WITH SINGLE TIRES AND SET AT NARROW WHEEL SPACING. THE POSSIBILITY OF TIPPING OVER DURING TURNS OR TRAVEL ON ROUGH ROADS IS INCREASED UNDER THESE CONDITIONS.



FIG. 3-8

CAUTION

- THIS IMPLEMENT IS NOT EQUIPPED WITH BRAKES. ENSURE THAT THE TOWING VEHICLE HAS ADEQUATE WEIGHT AND BRAKING CAPACITY TO TOW THIS IMPLEMENT.

IMPORTANT

- *It is strongly recommended to use the 120" wheel spacing while running single tires.*

See towing vehicle manual for towing and braking capacity. Maximum speed of sprayer should not exceed 20 m.p.h. with a wheeled undercarriage or 15 m.p.h. with a tracked undercarriage.

Secure drawbar pin with a locking device and lock tractor drawbar in centered position.

Secure transport chain to tractor chain support before transporting, see "Hitching to Tractor - Transport Chain" and FIG. 3-4. Regulate speed to road conditions and maintain complete control.

It is probable that this implement is taller, wider, and longer than the towing tractor. Become aware of and avoid all obstacles and hazards in the travel path of the equipment, such as power lines, ditches, etc.

Slow down before making sharp turns to avoid tipping. Drive slowly over rough ground and side slopes.

Always fold wings into transport position when sprayer is not in use.

Boom Operation

⚠ DANGER

- PERFORM BOOM UNFOLDING AND FOLDING OPERATIONS ONLY IN AREAS WITH ADEQUATE HEIGHT, WIDTH AND LENGTH CLEARANCES. IN PARTICULAR, BE MINDFUL OF LOCATION OF OVERHEAD POWER LINES. FAILURE TO DO SO CAN RESULT IN PERSONAL INJURY AND PROPERTY DAMAGE.



⚠ WARNING

- KEEP ALL PERSONNEL A SAFE DISTANCE AWAY FROM THE SPRAYER WHEN UNFOLDING OR FOLDING THE BOOM. PERSONAL INJURY CAN RESULT FROM IMPACT WITH BOOM.

Unfolding

1. Press top of ON/OFF switch to turn power on. (Red LED lamp on rocker switch should illuminate. Green LED lamp is provided to indicate circuit continuity when ever any other switch is pressed.) (FIG. 3-9)
2. Engage hydraulic lever to <RETRACT>.
3. Press and hold MAIN BOOM switch in <RAISE> position until boom is fully raised. This ensures that the transport latch is not supporting the weight of the boom.
4. Press and hold RH WING TILT and LH WING TILT switches in <UP> position until wings are fully tilted upward.



IMPORTANT

- *Wing tilt function may require several seconds of use before wings begin to move.*
5. Press and hold INNER WING switch in <EXTEND> position until wings are fully extended and wing locks are engaged on lock pins.
 6. Momentarily press WING TILT switches either <UP> or <DOWN> as required to approximately level the wings horizontally.
 7. Press and hold OUTER WING switch in <EXTEND> position until outer wings are fully extended.
 8. Momentarily press WING TILT switches either <UP> or <DOWN> as required to level the wings horizontally. (Observe the tilt indicators located near the tilt cylinders to assist with leveling the wings.)
 9. Press and hold MAIN BOOM switch in <LOWER> position until boom is at desired spray height.

IMPORTANT

- *Never unfold unit without attaching to tractor first. For proper boom suspension operation, do not operate boom in the fully lowered position. The minimum spray height is attained by lowering the boom fully, then raising it approximately 4 inches to permit adequate suspension travel.*

Boom Operation (continued)

Folding

1. Press top of ON/OFF switch to turn power on. (Red LED lamp on rocker switch should illuminate. Green LED lamp is provided to indicate circuit continuity when ever any other switch is pressed.) (FIG. 3-10)
2. Engage hydraulic lever to <RETRACT>
3. Press and hold OUTER WING switch in <RETRACT> position until outer wings are fully retracted.
4. Press and hold MAIN BOOM switch in <RAISE> position until boom is fully raised.
5. Press and hold RH WING TILT and LH WING TILT switches in <UP> position until wings are fully tilted upward.
6. Press and hold INNER WING switch in <RETRACT> position until wings are fully retracted.
7. Press and hold either RH WING TILT or LH WING TILT switch in <DOWN> position until each wing is seated in its wing rest. Repeat for opposite wing.



IMPORTANT

- Hold switch in <DOWN> position after wing is seated for 10 seconds to allow the accumulators to drain.
8. Press and hold MAIN BOOM switch in <LOWER> position to allow boom to lower approximately 6 inches until transport lock is engaged.

IMPORTANT

- If boom does not engage transport lock, raise boom fully, press and hold INNER WING switch in <RETRACT> position for 5 seconds, and then repeat step 8.
- Hold switch in <DOWN> position after wing is seated for 10 seconds to allow the accumulators to drain.

Electric Recirculating Valve Operation

IMPORTANT

- *Recirculation for boom valve only operates with GEN 1 ISO harnessing and foot switch. If unit is not equipped with GEN 1 ISO harnessing, the boom valve is off and does not allow recirculation to operate.*

NOTE: For units equipped with foot switch, continue to steps 1 and 2. If not equipped with foot switch, go to steps 3 and 4.

1. Click on foot switch. This turns OFF / CLOSES recirculating valve.
2. Click off foot switch. This turns ON / OPENS recirculating valve.
3. If not equipped with foot switch, the recirculating valve is OFF / CLOSED.
4. To manually enable recirculating valve, refer to “Manual Override for Electric Recirculating Valve” in this section.

Manual Override for Electric Recirculating Valve

WARNING

- **TIPPING OR MOVEMENT OF THE MACHINE CAN CAUSE SERIOUS INJURY OR DEATH. BE SURE MACHINE IS SECURELY BLOCKED. SPRAYER MUST BE HITCHED TO THE TRACTOR BEFORE OPERATING BOOM.**
- **ALWAYS WEAR PERSONAL PROTECTIVE EQUIPMENT WHEN WORKING WITH OR NEAR CHEMICALS. THIS EQUIPMENT INCLUDES, BUT IS NOT LIMITED TO: PROTECTIVE EYE WEAR, GLOVES, SHOES, SOCKS, LONG-SLEEVED SHIRT, AND LONG PANTS. ADDITIONAL PROTECTION MAY BE REQUIRED FOR MANY TYPES OF CHEMICALS.**
- **KEEP HANDS CLEAR OF PINCH POINT AREAS.**
- **RESIDUAL PRESSURE MAY EXIST IN SPRAYER PLUMBING EVEN WHEN UNIT IS NOT IN USE. RELIEVE PRESSURE BEFORE SERVICING ANY PLUMBING.**

IMPORTANT

- *Recirculation for boom valve only operates with GEN 1 ISO harnessing and foot switch. If unit is not equipped with GEN 1 ISO harnessing, the boom valve is off and does not allow recirculation to operate.*

NOTE: If electric recirculating valve does not have power or is not operating correctly, the manual override operation is intended for emergency use **ONLY** and is not intended for continuous operation.

1. Park empty unit on a firm, level surface. Block machine to keep it from moving. Set vehicle's parking brake, shut off the engine, remove the ignition key and disconnect hydraulics from the towing vehicle to the machine.



2. If not equipped with foot switch or to bypass / disable recirculating valve, ensure manual recirculating valve handle is in OFF / CLOSED position (FIG. 3-11)
3. To enable, turn manual recirculating valve handle 90 degrees counterclockwise to ON / OPEN position. (FIG. 3-12)

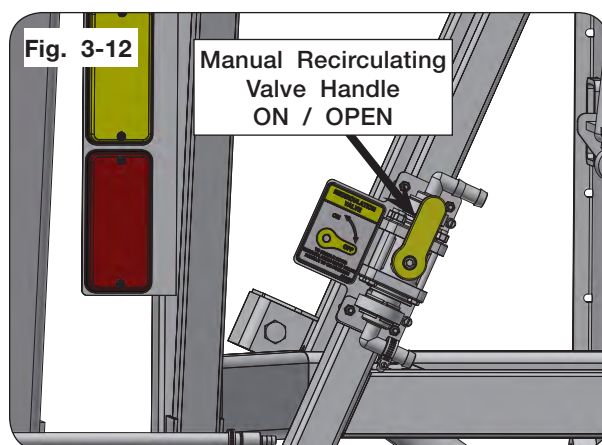
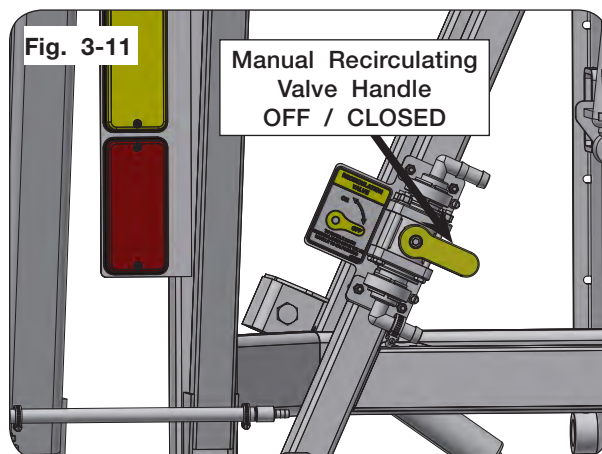

Filling Sprayer

Quick Fill

1. Assure that QUICK-FILL VALVES are <OFF>.
2. Turn PUMP INLET SELECTOR VALVE to <SOLUTION TANK>. (FIG. 3-13)
3. To fill Rinse Tank, attach hose to the 2" right side quick fill coupler. Turn rinse tank quick-fill valve on the sprayer frame <ON>.
4. To fill Solution Tank, attach hose to the 3" left side quick fill coupler. Turn quick-fill valve on the solution tank <ON>.

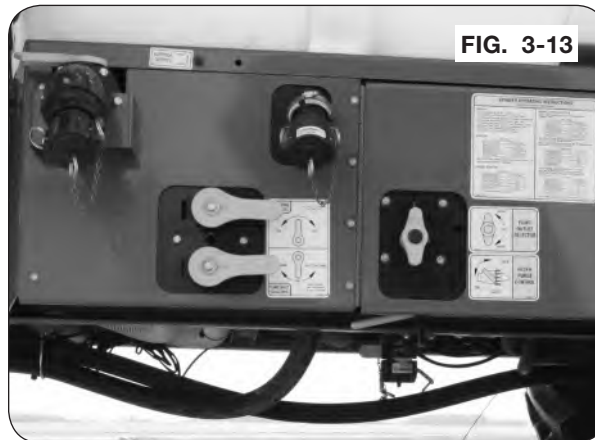

CAUTION

- NEVER LEAVE SPRAYER UNATTENDED WHILE FILLING. TANK CONTENTS MAY SPILL OUT OF AIR VENTS IF OVERFILLED.

5. Return valve to <OFF> when filling is complete.

IMPORTANT

- *The solution tank is designed with additional air expansion space in excess of the rated capacity. The full capacity can be reached with the level approximately 6"- 8" below the top surface of the tank access hatch (lid opened).*

Tank Mixing

Spray chemicals can be added to the solution tank by either pouring directly into the top tank access hatch, or through the use of an optional inductor. Before adding chemicals, ensure that the tank contains at least 50 gallons of water.

WARNING

- ALWAYS WEAR PERSONAL PROTECTIVE EQUIPMENT WHEN WORKING WITH OR NEAR CHEMICALS. THIS EQUIPMENT INCLUDES, BUT IS NOT LIMITED TO: PROTECTIVE EYE WEAR, GLOVES, SHOES, SOCKS, LONG-SLEEVED SHIRT, AND LONG PANTS. ADDITIONAL PROTECTION MAY BE REQUIRED FOR MANY TYPES OF CHEMICALS.

The solution tank is equipped with dual mixing inductors for agitation, which use a fraction of the pump output to keep chemicals in solution. Always allow enough time for complete mixing of the tank contents before starting any spraying operation.

Rinsing Sprayer

Solution Tank

IMPORTANT

- When pulling out of tank, always discharge liquid. Do not allow pump to run dry. Pump damage will result.

1. Engage hydraulic circuit to RETRACT position.
2. Rinse Flo-Bak return line by running pump with the following settings:

VALVE SETTINGS

PUMP INLET SELECTOR	<RINSE TANK>
INDUCTOR FLOW (OPT)	<OFF>
FILTER PURGE CONTROL	<PARTIALLY OPEN>
PUMP OUTLET SELECTOR	<BOOM>
AGITATION CONTROL	<PARTIALLY OPEN>

3. Rinse main tank by running pump with the following settings, using approximately 1/2 of available rinse water:

VALVE SETTINGS

PUMP INLET SELECTOR	<RINSE TANK>
INDUCTOR FLOW (OPT)	<OFF>
FILTER PURGE CONTROL	<OFF>
PUMP OUTLET SELECTOR	<RINSE>
AGITATION CONTROL	<OFF>

4. Make sure all the boom sections are on. Turn on the master switch. Allow water to spray for 5 seconds. Shut master switch off . Repeat sequence twice.

VALVE SETTINGS

PUMP INLET SELECTOR	<SOLUTION TANK>
INDUCTOR FLOW (OPT)	<OFF>
FILTER PURGE CONTROL	<OFF>
PUMP OUTLET SELECTOR	<BOOM>
AGITATION CONTROL	<OFF>

5. Repeat Steps 3 and 4.

Boom Only Tank

IMPORTANT

- Turn on master switch to activate boom.
- When pulling out of tank, always discharge liquid. Do not allow pump to run dry. Pump damage will result.
- When pulling water out of the rinse tank with the pump running, rinse tank volume is consumed due to the recirculation valve.

VALVE SETTINGS

PUMP INLET SELECTOR	<RINSE TANK>
INDUCTOR FLOW (OPT)	<OFF>
FILTER PURGE CONTROL	<OFF>
PUMP OUTLET SELECTOR	<BOOM>
AGITATION CONTROL	<OFF>

Foam Marker

The optional foam marker for this sprayer automatically mixes foam concentrate and water. Clean water is taken directly from the rinse tank, and foam concentrate is drawn from a separate tank.

Filling

Since the water used comes directly from the rinse tank, ensure that the rinse tank is full before starting spray operation. This tank can be filled either through the fill cap or the quick-fill connector.

To fill the foam concentrate tank (located on service platform) (FIG. 3-14), remove the cap and add diluted foam concentrate. Dilute concentrate 50/50 with water to ensure good flow characteristics.

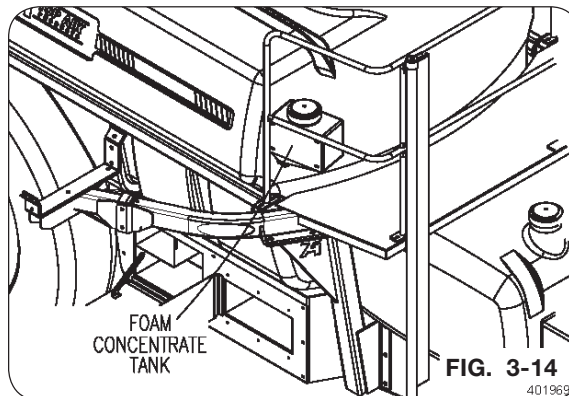

Foam Collector Height

Adjust foam collector drop hose until collector is at least one foot above the ground, or to desired length.

Basic Operation

Before starting spray operation, test foam output to ensure that foam density and delivery rate are acceptable. (Additional information on troubleshooting foam output can be found in the MAINTENANCE section)

1. Press switch LEFT or RIGHT to activate system. Foam should begin to drop from foam heads within approximately 1 to 3 minutes. (FIG. 3-15)
2. Move switch to center position to stop flow of foam.



Chemical Inductor

Basic Operation

IMPORTANT

- Solution tank should contain at least 50 gallons of liquid.
1. Unlatch inductor lift mechanism and lower to “fill” position. (FIG. 3-16)



2. Set valves:

VALVE SETTINGS

PUMP INLET SELECTOR	<SOLUTION TANK>
AGITATION CONTROL	<OFF>
FILTER PURGE CONTROL	<OFF>
PUMP OUTLET SELECTOR	<BOOM>
INDUCTOR MIX	<OFF>
INDUCTOR DRAIN	<OFF>
INDUCTOR FLOW	<ON>

3. Start pump.
4. Open INDUCTOR DRAIN valve.
5. Open lid and pour chemical into inductor tank. (If using dry chemical, open INDUCTOR MIX valve to mix chemical, using care not to overfill inductor tank.)
6. Close INDUCTOR DRAIN valve when tank is completely empty.
7. Close INDUCTOR FLOW valve then set AGITATION CONTROL and FILTER PURGE CONTROL to proper settings.
8. Close lid.
9. Raise tank to storage position.

(Continued on next page)

WARNING

- WHEN USING JUG RINSER, BE CAREFUL NOT TO SPRAY SOLUTION INTO EYES OR FACE.



Chemical Inductor (continued)

Chemical Container and Inductor Tank Rinsing

Both chemical containers and the inductor tank itself can be rinsed by using clean water from the rinse tank. To do so, ensure that the rinse tank is at least 1/2 full, and use the following procedure:

1. Perform steps 1 through 4 under “Basic Operation” of inductor.
2. Quickly move PUMP INLET SELECTOR valve from <SOLUTION TANK> to <RINSE TANK>.

IMPORTANT

- *It is recommended to work efficiently while the sprayer pump is drawing from the rinse tank, as the rinse water is returned to the solution tank not the rinse tank, and therefore the rinse tank will eventually become empty.*
 - *Do not allow pump to run dry. Pump damage will result.*
3. To rinse a chemical container, place container upside down on rinse nozzle and squeeze handle on rinse wand.
 4. To rinse inductor tank, close lid, open INDUCTOR MIX valve and squeeze rinse wand handle for approximately 10 seconds.
 5. Close INDUCTOR MIX valve and release rinse wand when rinsing is complete.
 6. Repeat steps 4 and 5 for additional rinsing, if desired.
 7. When inductor tank is empty, close INDUCTOR DRAIN valve, and quickly move PUMP INLET SELECTOR valve from <RINSE TANK> to <SOLUTION TANK> to minimize the amount of rinse water used.
 8. Close INDUCTOR FLOW valve then set AGITATION CONTROL and FILTER PURGE CONTROL to proper settings.
 9. Raise tank to storage position.

Electric Command Center

The optional electric command center allows remote operation of rinse system, agitation control, and filter purge control. Basic sprayer operation and tank rinsing is similar to the procedure outlined previously, with the following exceptions:

Filter Purge Controls

This control is operated by momentarily actuating the appropriate switch on the control box, instead of using the manual lever located behind the Command Center access door. The control valve cycles from fully closed to fully open in about 7 seconds. The valve setting for each control is determined by monitoring the pressure drop while actuating the switches.

Pump Inlet/Outlet Controls

Pump Inlet and Pump Outlet control switches are “circuit selectors” and do not modulate flow like the Agitation and Filter Purge switches. Although their function is nearly identical to the manual valves of the standard Command Center, it should be noted that there is no <OFF> position with either valve. Because of this, a manual shut-off valve is provided on the Command Center to isolate the tank during plumbing service, or to restrict the pump inlet flow during use of the optional inductor system.



FIG. 3-18

Fence Row Nozzle

The fence row is controlled by two switches on the Electric Command Center/switch box (9007776) (FIG. 3-19). The left-hand (LH) switch turns the left nozzle on; the right-hand (RH) switch turns the right nozzle on.



FIG. 3-19

XRT Autoboam Height Control

Refer to Raven XRT Autoboam Height Control Operations Manual.

Steerable Hitch

Refer to Raven Steerable Hitch Operations Manual.

Hydraulic Instructions

HYPRO Pump

As the signal current increases, the hydraulic flow control valve opens.

To ensure proper hydraulic oil flow metering, follow the calibration procedure described by the manufacturer of the controller that is being used as each controller's procedure is different. In general, balancing reaction time and system stability are key to proper calibration.

The hydraulic flow control valve has a manual override option fitted from the factory. This feature can be used to open or close the valve in the event that the digital controller has an error or fails. To use this feature, remove the override cover on the top of the valve to reveal the red override toggle. The override is engaged by turning the toggle clockwise. One full turn is required to start opening the valve and full open is achieved with 6 full turns. To close the valve, turn the toggle counter clockwise 6 turns until a stop is reached.

Connections to the control assembly are SAE #10 (7/8-14 UNF-2B) O-ring boss ports. Ensure that the mating fitting has an O-ring free of any debris or damage before installation.

Match the high pressure line to the port labelled "IN" and the low pressure line back to tank to the port labelled "OUT".

The port labelled "BYPASS" is a SAE #8 (3/4-16 UNF-2B) port intended return excess oil flow back to the reservoir. This port comes plugged from the factory. When plugged, the hydraulic control assembly can be used with hydraulic circuits that have a variable displacement pump. If the hydraulic circuit uses a fixed displacement pump, the plug must be removed and a line should be run from the bypass port to the reservoir. The maximum input flow is 30 GPM (114 LPM) for the bypass configuration.

Notes

Section IV Maintenance

Lubrication.....	4-2
Spray Pump - ACE HYD 750 Inflation.....	4-4
Sprayer Calibration - Verify Nozzle Flow.....	4-5
Equalizer® Track System.....	4-5
Wing Adjustments - 60' / 80' / 90' / 100' Booms.....	4-6
Outer Wing Adjustments.....	4-6
Wing Tilt Indicator Adjustment.....	4-6
Wing Tip Breakaway Mechanism.....	4-7
Boom Twin Link Suspension Adjustment.....	4-8
Wing Adjustments - 80' / 90' / 100' Booms.....	4-9
Inner Wing Adjustment.....	4-9
Inner Wing Alignment.....	4-9
Wing Latch Pin.....	4-9
Main Wing Fold Cylinder (60' Boom Included).....	4-10
Gull Wing Link.....	4-10
Wing Adjustments - 120' / 132' Booms.....	4-11
Inner Wing Adjustments.....	4-11
Intermediate Wing Adjustment.....	4-11
Main Wing Fold Cylinder.....	4-12
Outer Wing Adjustments.....	4-12
Wing Tilt Indicator Adjustment.....	4-13
Wing Tip Breakaway Mechanism.....	4-13
Boom Twin Link Suspension Adjustment.....	4-14
Filters.....	4-15
Self-Cleaning (Primary) Filter.....	4-15
Secondary Filter.....	4-16
Foam Marker.....	4-17
Filter Maintenance.....	4-17
Chemical Inductor.....	4-18
Chemical Container and Inductor Tank Rinsing.....	4-18
Sprayer Maintenance.....	4-20
Seasonal Storage.....	4-20
Winterizing.....	4-21
Sprayer Plumbing.....	4-21
Foam Marker (Optional).....	4-22
Chemical Inductor (Optional).....	4-22
Gauge Panel.....	4-22
Schematics.....	4-23
Wheel, Hub and Spindle Disassembly and Assembly.....	4-36
Wheels and Tires.....	4-38
Wheel Nut Torque Requirements.....	4-38
Tire Pressure.....	4-39
Tire Warranty.....	4-39
Tracks - Warranty.....	4-40
Complete English and Metric Torque Chart.....	4-41
Hydraulic Fittings - Torque and Installation.....	4-42

Lubrication (continued)

Lubricate the hubs in area shown below:

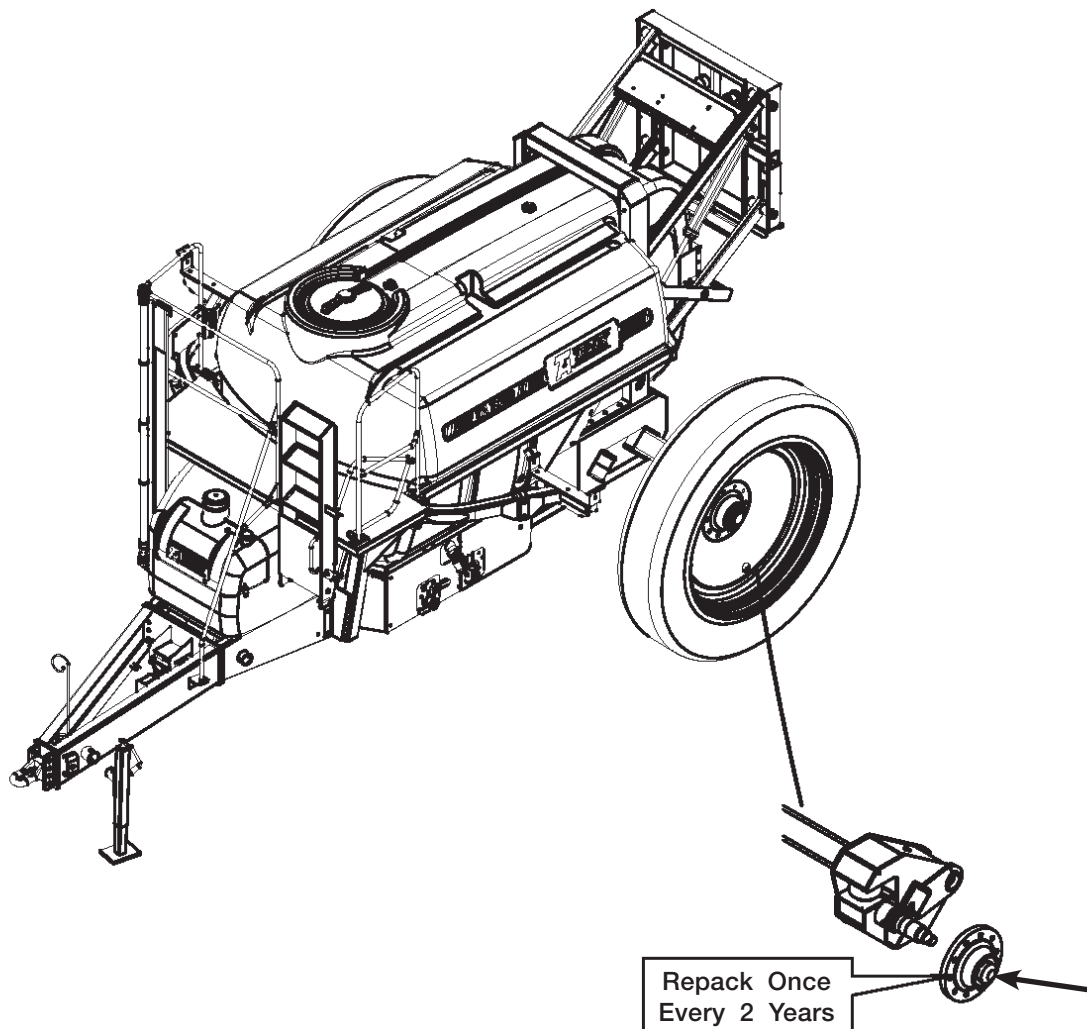

Spray Pump

ACE HYD 750 Inflation

IMPORTANT

- Inflation valve must be assembled in the “IN” port of the regulating valve.

1. Turn regulating valve adjusting knob counter-clockwise until it is at the minimum pressure setting. (FIG. 4-1)
2. Attach air chuck to air valve.
3. Turn adjusting knob on regulating valve clockwise until gauge reads 30 psi. (FIG. 4-1)
4. Remove the air pressure before disconnecting the hose. To add barrier fluid to the fluid chamber, disconnect the hose from the fitting on top of the hydraulically driven centrifugal pump. Remove the fitting on top of the pump. (FIG. 4-2)
5. Fill the fluid chamber by either attaching a 1/8” hose to the barrier fluid and using the hose to fill the fluid chamber where fitting was removed. (FIG. 4-3)
6. Add fluid until level is half-way up the sight gauge on the side of the pump.

NOTE: Any 1/8” hose will attach to the nipple of the barrier fluid bottle (9005518) to ease filling of the sight gauge. (FIG. 4-3)

At the end of each season, it is recommended to change/check the barrier fluid and seal. Follow the guidelines below.

- The pump requires pressure and/or fluid more frequently. Change barrier fluid and seal.
- The barrier fluid becomes cloudy, discolored, or water mixes with barrier fluid. Change barrier fluid and seal.
- The barrier fluid is clear. No service needed. Refill and store for the winter.

Refer to ACE pump manual and operating instructions.



FIG. 4-1

FIG. 4-2

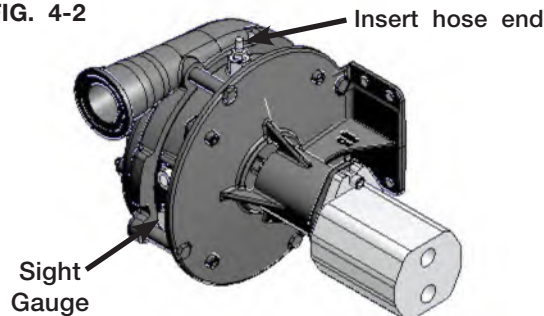

FIG. 4-3

Sprayer Calibration

Verify Nozzle Flow

The following procedure should be repeated periodically to verify the flow rate of the spray nozzles.

IMPORTANT

- *Use water when verifying nozzle flow rate.*
1. Turn on sprayer and set flow such that tip pressure is within the nozzles' pressure range. Choose a pressure setting that coincides with a listing for nozzle being used, in order to have a comparison to the advertised flow value.
 2. Using a calibrated container (TA890020), collect flow from new tip for exactly 1 minute. Compare with advertised value at the pressure setting chosen. (Divide by 128 to obtain GPM, if ounces are being measured.)
 3. Measure flow from several other nozzles for the same 1-minute interval.
 4. Compare flow rate of other tips with flow rate from the new tip. If flow rate from any tip varies by more than 10% from the new tip, replacement is necessary. If more than one tip has an incorrect flow rate, replace all tips.

Equalizer® Track System

Refer to the Equalizer® Track System sprayer manual for information regarding the horizontal track.

Wing Adjustments - 60' / 80' / 90' / 100' Booms

Outer Wing Adjustments

The outer wing contacts a rubber bumper when fully extended. Periodically inspect bumper for deterioration and replace if necessary.

To adjust levelness of outer wing, add or remove washers behind rubber bumper.

An additional area of level adjustment can be obtained by loosening the bolts securing the ramp casting on the breakaway mechanism, and sliding the casting along its mounting slots. (FIG. 4-4)

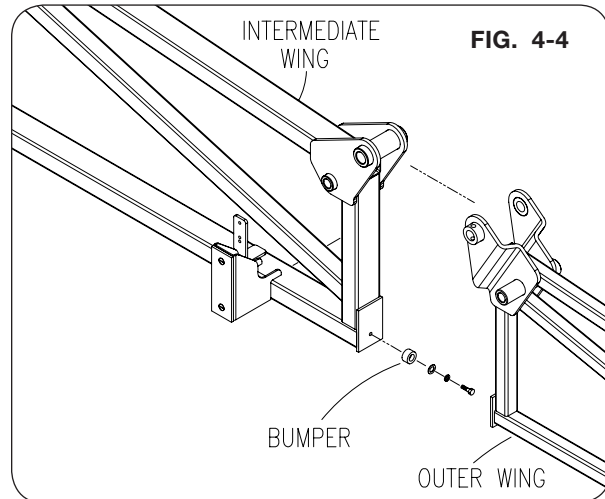

Wing Tilt Indicator Adjustment

The wing tilt indicators (mounted on the inner wings) are adjustable to accurately indicate level orientation.

1. Park sprayer on level surface.
2. Fully extend boom, leveling the wings visually.
3. Using a level on the lower tubes of the three inner wing sections, fine-tune the tilt cylinder lengths until the boom sections are as level as possible.
4. Loosen the tilt indicator bracket on either inner wing and slide until the indicator pointer lines up with the primary mark on the indicator. (FIG. 4-5)
5. Tighten tilt indicator brackets.

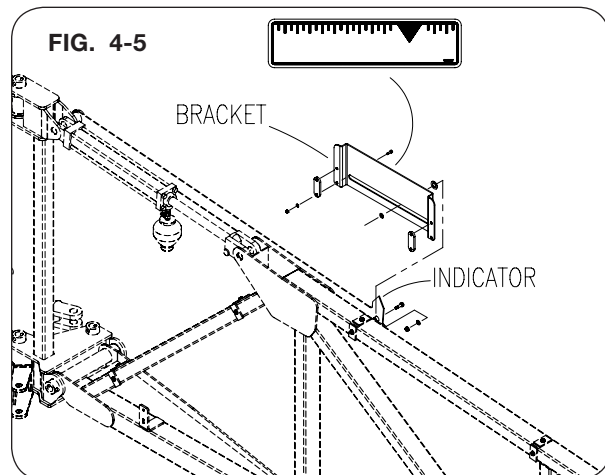

Wing Adjustments - 60' / 80' / 90' / 100' Booms (continued)

Wing Tip Breakaway Mechanism

The force required to operate the wing tip breakaway section is adjustable. The nominal setting is obtained when the spring length is adjusted to X, as shown in (FIG. 4-6)

X = 7 1/8" for 60'/80' Boom

X = 6 1/2" for 90'/100' Boom

Use the 3/4" jam nuts at the bottom of the pivot shaft to adjust the spring installed height.

If an excessive amount of force is required to break the wings away, lengthen spring until a reasonable amount of force required to break wing away is achieved. The breakaway force should always be less than the amount of force required to damage the wing.

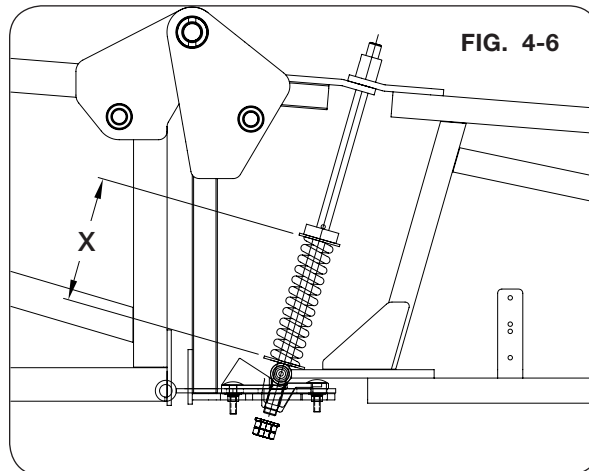

To service the rollers on the breakaway mechanism, use the following procedure:

1. Fully loosen 3/4" jam nuts at bottom of the pivot shaft to remove spring pressure.
2. Loosen setscrews that lock roller wheel bolts in place.
3. Remove roller wheel bolts to disassemble rollers. Replace components as needed.
4. During reassembly, tighten the wheel bolts until all measurable clearance is removed. The wheel should spin freely. Always apply anti-seize to roller bushings and roller ID to ensure rollers do not seize up.
5. Tighten setscrews to lock wheel bolts in place.

Wing Adjustments - 60' / 80' / 90' / 100' Booms (continued)

Boom Twin Link Suspension Adjustment

The side-to-side sway feature, (Twin Link suspension) of the boom must be adjusted correctly to maximize boom stability during operation.

1. Park sprayer on level surface.
2. Fully extend and lower boom. Use tilt controls to adjust both wings as straight as possible with each other and the center section.
3. Place a level on lower horizontal tube of boom center section. Raise and support either end of boom as necessary to achieve level condition.
4. Adjust both stop bolts until a clearance exists between bolt heads and boom support. Readjust stop bolts until bolt head begins to touch boom support. (FIG. 4-7)
5. Loosen stop bolt lock nuts. Loosen each stop bolt 5 full turns for 80'/90'/100' booms and 2 full turns for 60' booms.
6. Tighten locknuts.

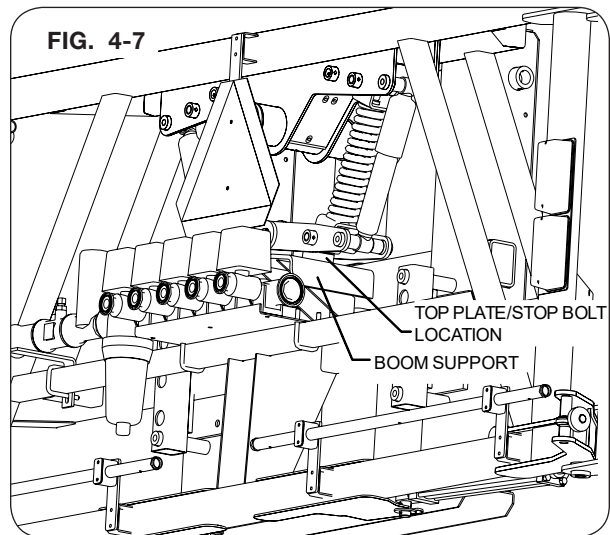

IMPORTANT

- *The optimum adjustment is achieved when both stop bolts are fully contacting boom support when level but clearance is obtained with a minimum amount of lift distance at tip of boom.*

Wing Adjustments - 80' / 90' / 100' Booms

Several areas of adjustment have been designed into the booms to maintain proper wing folding operation throughout the life of the booms.

Inner Wing Adjustments

Due to the interrelated nature of the adjustments of the inner wings, these steps should be verified or adjusted in the sequence presented.

Inner Wing Alignment

1. Hitch sprayer to tractor and fully extend boom.
2. Verify that steel bumper on inner wing is in firm contact with intermediate wing. If wing motion is insufficient to allow steel bumper to contact intermediate wing, perform the following preliminary gull wing link adjustment: (FIG. 4-8)
 - a. Remove the two 3/8" x 1" bolts on the gull wing link at its flange joint.
 - b. Loosen tie rod jam nut on gull wing link.
 - c. Rotate gull wing link tube until bumper on inner wing contacts intermediate wing. Continue to rotate tube as necessary to align holes at flange joint.
 - d. Install bolts and tighten jam nut.
5. Vary amount of washers under bumper until desired degree of straightness between wing sections is achieved.

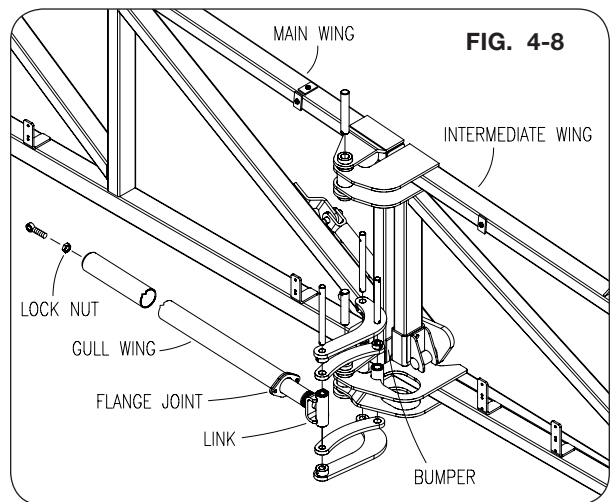

Wing Latch Pin

1. Hitch sprayer to tractor and fully extend boom.
2. Verify that the steel bumper on the inner wing is in firm contact with intermediate wing. If necessary for bumper to contact intermediate wing, perform preliminary Gull Wing Link adjustment. (FIG. 4-9)
3. The latch pin is correctly adjusted when latch fully engages pin, but does not allow pin to bottom-out in latch slot. Remove or add shims behind pin weldment as necessary to achieve correct adjustment. (FIG. 4-9)

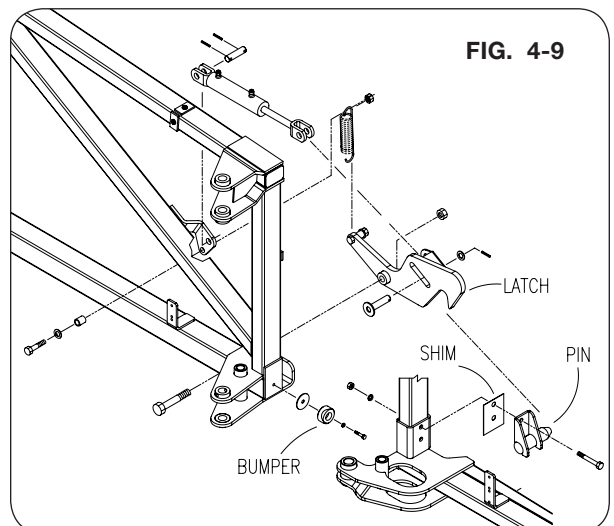

Wing Adjustments - 80' / 90' / 100' Booms (continued)

Main Wing Fold Cylinder (60' Boom Included)

Use the following procedure on these booms:

1. Beginning with wings fully extended and relatively level, adjust jam nuts near head of cylinder until each inner wing section is aligned with the center wing section.
2. Perform steps 1-5 from previous procedure.
3. Inspect position of wings, relative to wing rests. If wings do not line up reasonably well with wing rests, adjust main wing fold cylinder stop bolts as needed until wings align correctly with wing rests. (FIG. 4-10)

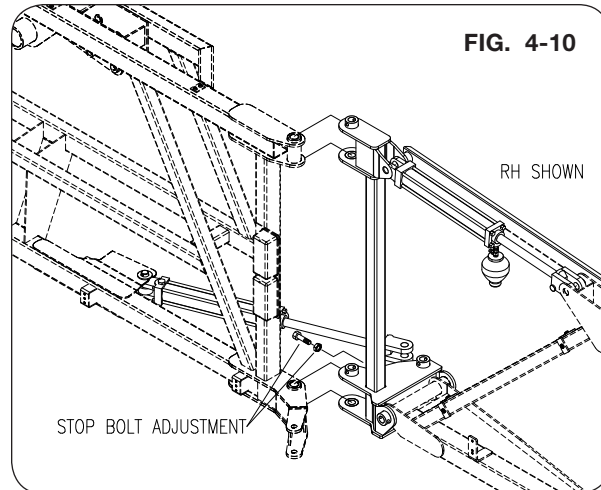

Gull Wing Link

Lastly, the adjustment of the gull wing link should be verified. The correct adjustment of this link allows the wing latch to engage the latch pin when the wing is fully extended, while permitting the intermediate wing to fully fold against the inner wing when fully retracted.

1. Fully extend main wings. If either wing latch does not engage its latch pin, lengthen the gull wing link on that wing 1/2 turn, using the preliminary Gull Wing Link adjustment procedure previously described.
2. Fully raise main lift and retract tilt cylinders to fully tilt wings upward.
3. Fully retract, then extend main wings.
4. If either wing latch still does not engage its latch pin, lengthen the gull wing link on that wing an additional 1/2 turn and repeat steps 2 and 3 until both latches engage their latch pins when wings are extended.
5. Fully retract main wings, then lower onto wing rests. If either intermediate wing does not fold completely, extend main wings and shorten the gull wing link on that side a half turn at a time until wing latches will no longer engage when the wings are extended. When this is achieved, lengthen gull wing link 1/2 turn to complete adjustment.

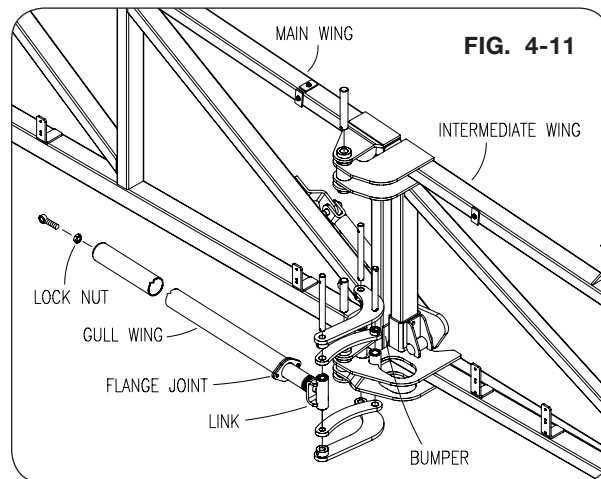

IMPORTANT

- If the above procedure cannot achieve a satisfactory wing adjustment, check for lost motion from worn or damaged linkage pins and/or bushings. Also check for deteriorated yaw control bushings. Repair as necessary and repeat adjustment procedure.

Wing Adjustments - 120' / 132' Booms

Several areas of adjustment have been designed into the booms to maintain proper wing folding operation throughout the life of the booms.

Inner Wing Adjustments

Use the following procedure to align main wings with center section:

1. Hitch sprayer to tractor and fully extend boom.
2. Front-to-rear angle of each main wing section is adjusted by loosening one of two nuts indicated in (FIG. 4-12), followed by fully tightening opposite nut.

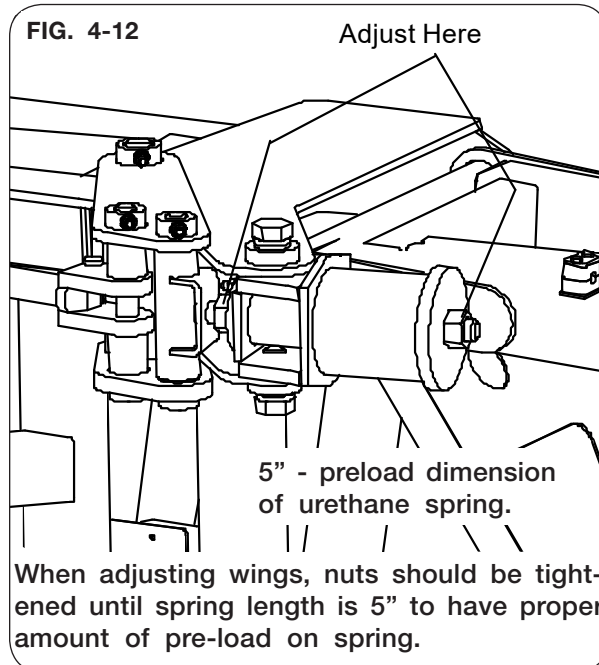

Intermediate Wing Adjustment

For proper boom performance, the intermediate wing latch must fit tightly to the latch pin.

1. Hitch sprayer to tractor and fully extend boom.
2. Loosen four bolts on side of latch plate. (FIG. 4-13)
3. Using stop bolt, adjust latch plate until all clearance to latch pin is removed. (FIG. 4-13)
4. Tighten bolts loosened in Step 2. Tighten bolt and jam nut.
5. Fully fold and unfold main wings. Readjust latch plate if necessary for correct operation.

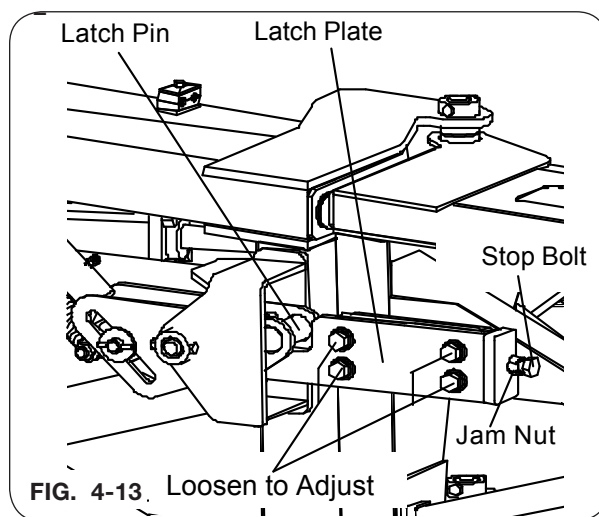

Wing Adjustments - 120' / 132' Booms (continued)

Main Wing Fold Cylinder

Use the following procedure to adjust the alignment of the boom with the wing rests:

1. Begin with the wings in the unfolded position.
2. Retract outer wings and extend tilt cylinders to fully tilt wings upward.
3. Fully raise the main lift.
4. Fully retract main wings.
5. Carefully lower main wings by retracting tilt cylinders. (It may take several seconds before wings begin lowering.) Stop lowering wings just before they enter wing rests.
6. Inspect position of wings, relative to wing rests. If wings do not line up reasonably well with wing rests, adjust main wing fold cylinder stop bolts as needed until wings align correctly with wing rests. (FIG. 4-14)

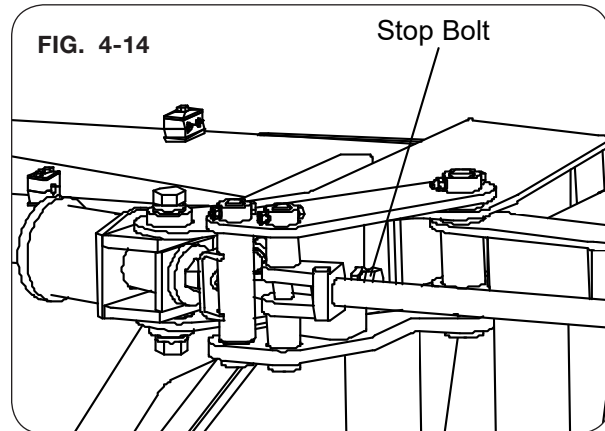

Outer Wing Adjustments

The outer wing contacts a rubber bumper when fully extended. Periodically inspect bumper for deterioration and replace if necessary. (FIG. 4-15)

To adjust levelness of outer wing, add or remove washers behind rubber bumper.

An additional area of level adjustment can be obtained by loosening the bolts securing the ramp casting on the breakaway mechanism, and sliding the casting along its mounting slots.

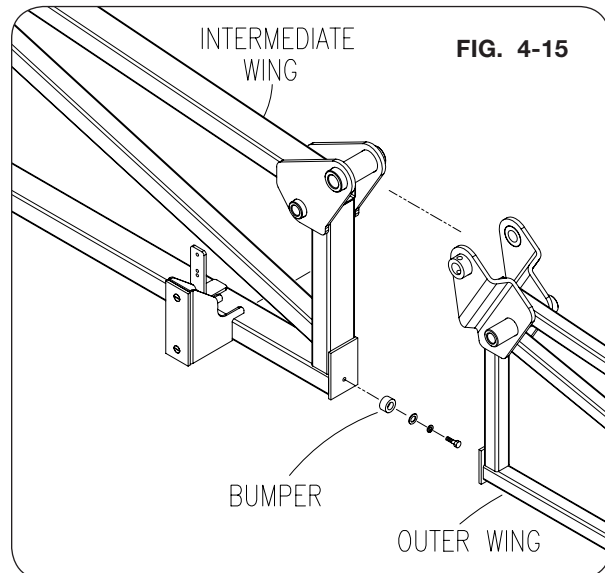

Wing Adjustments - 120' / 132' Booms (continued)

Wing Tilt Indicator Adjustment

The wing tilt indicators (mounted on the inner wings) are adjustable to accurately indicate level orientation.

1. Park sprayer on level surface.
2. Fully extend boom, leveling the wings visually.
3. Using a level on the lower tubes of the three inner wing sections, fine-tune the tilt cylinder lengths until the boom sections are as level as possible.
4. Loosen the tilt indicator bracket on either inner wing and slide until the indicator pointer lines up with the primary mark on the indicator. (FIG. 4-16)
5. Tighten tilt indicator brackets.

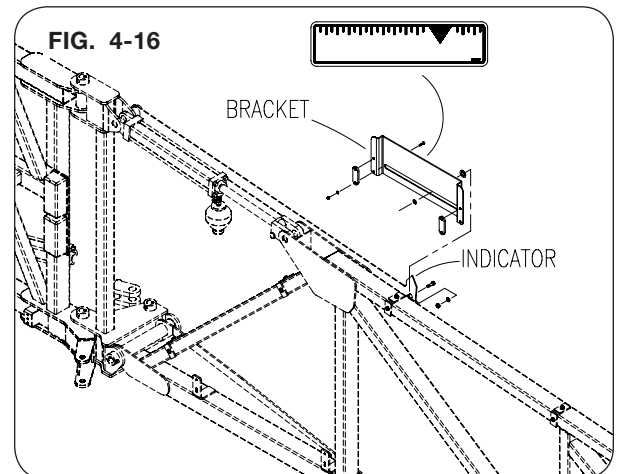

Wing Tip Breakaway Mechanism

The force required to operate the wing tip breakaway section is adjustable. The nominal setting is obtained when the spring length is adjusted to 7-1/8", as shown in (FIG. 4-17). Use the 3/4" jam nuts at the bottom of the pivot shaft to adjust the spring installed height.

If an excessive amount of force is required to break the wings away, lengthen spring until a reasonable amount of force required to break wing away is achieved. The breakaway force should always be less than the amount of force required to damage the wing.

To service the rollers on the breakaway mechanism, use the following procedure:

1. Fully loosen 3/4" jam nuts at bottom of the pivot shaft to remove spring pressure.
2. Loosen setscrews that lock roller wheel bolts in place.
3. Remove roller wheel bolts to disassemble rollers. Replace components as needed.
4. During reassembly, tighten the wheel bolts until all measurable clearance is removed. The wheel should spin freely. Always apply anti-seize to roller bushings and roller ID to ensure rollers do not seize up.
5. Tighten setscrews to lock wheel bolts in place.

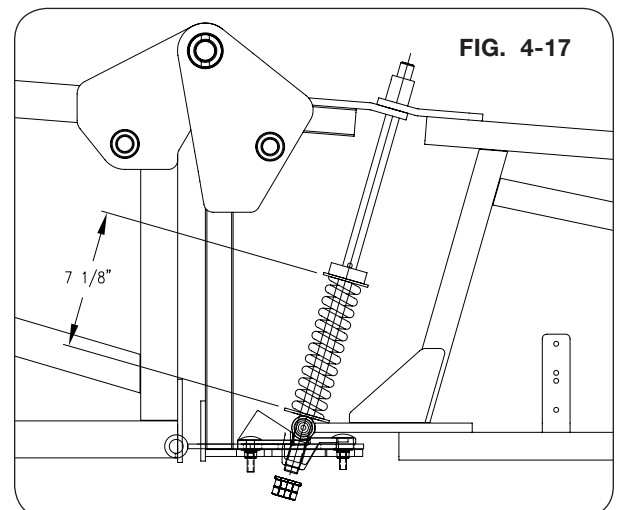

Wing Adjustments - 120' / 132' Booms (continued)

Boom Twin Link Suspension Adjustment

1. Park sprayer on level surface.
2. Fully extend and lower boom. Use tilt controls to adjust both wings as straight as possible with each other and the center section.
3. Loosen jam nut under adjustment shaft bushing. Remove spring yoke set screw. (FIG. 4-18)
4. Place a level on lower horizontal tube of boom center section. Turn adjustment shaft to level boom.
5. Reinsert spring yoke set screw and tighten. Fully tighten adjustment shaft jam nut beneath adjustment shaft bushing.

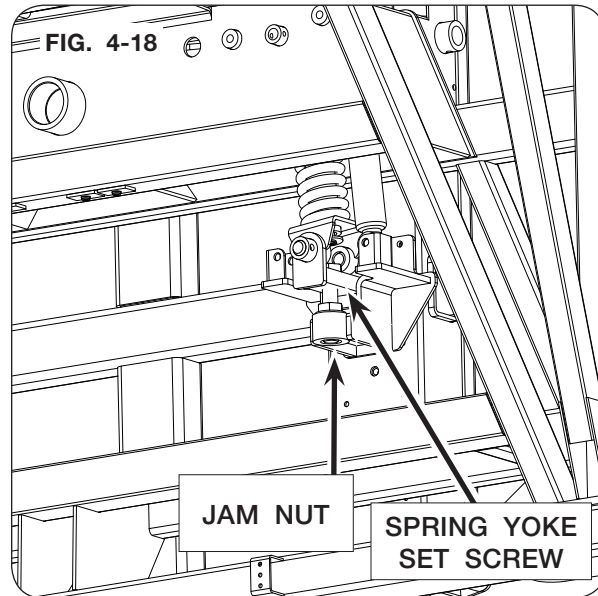

Filters

Self-Cleaning (Primary) Filter

This sprayer uses two filters to help ensure proper spraying operation. These filters will need to be cleaned periodically during use and prior to sprayer storage.

WARNING

- **ALWAYS WEAR PERSONAL PROTECTIVE EQUIPMENT WHEN WORKING WITH OR NEAR CHEMICALS. THIS EQUIPMENT INCLUDES, BUT IS NOT LIMITED TO: PROTECTIVE EYE WEAR, GLOVES, SHOES, SOCKS, LONG-SLEEVED SHIRT, AND LONG PANTS. ADDITIONAL PROTECTION MAY BE REQUIRED FOR MANY TYPES OF CHEMICALS.**
- **RESIDUAL PRESSURE MAY EXIST IN SPRAYER PLUMBING EVEN WHEN UNIT IS NOT IN USE. RELIEVE PRESSURE BEFORE SERVICING ANY PLUMBING.**

The strainer in this filter is continually flushed during use, forcing larger contaminants that cannot pass through the filter screen to be sent back to the solution tank. Since most of these larger contaminants are simply undissolved chemicals, the agitation action in the tank will break down most of this material and allow it to become dissolved. However, some foreign material will not break down, such as rocks, paper labels, etc., and eventually the filter will need to be removed for cleaning.

To clean the filter located at the rear of the command center on the left side of the sprayer, refer to (FIG. 4-19):

1. Rotate the pump outlet valve to <OFF>.
2. Remove the clamp at the bottom of the filter to disconnect the flush hose.
3. Unscrew the filter housing by turning counter-clockwise and remove the filter screen.
4. Clean filter by flushing strainer element with water.
5. Reassemble filter and check for leaks.

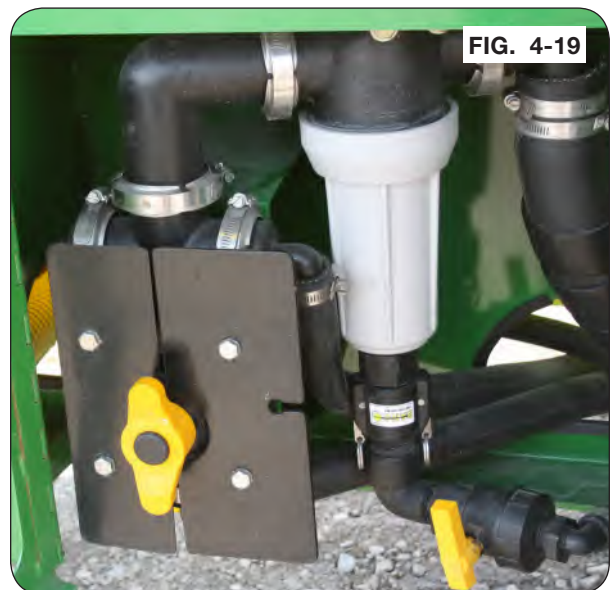

Filters (continued)

Secondary Filter

This sprayer uses two filters to help ensure proper spraying operation. These filters will need to be cleaned periodically during use and prior to sprayer storage.

⚠ WARNING

- ALWAYS WEAR PERSONAL PROTECTIVE EQUIPMENT WHEN WORKING WITH OR NEAR CHEMICALS. THIS EQUIPMENT INCLUDES, BUT IS NOT LIMITED TO: PROTECTIVE EYE WEAR, GLOVES, SHOES, SOCKS, LONG-SLEEVED SHIRT, AND LONG PANTS. ADDITIONAL PROTECTION MAY BE REQUIRED FOR MANY TYPES OF CHEMICALS.
- RESIDUAL PRESSURE MAY EXIST IN SPRAYER PLUMBING EVEN WHEN UNIT IS NOT IN USE. RELIEVE PRESSURE BEFORE SERVICING ANY PLUMBING.

A secondary filter is located on the boom center section, just prior to the boom electric valves, (FIG. 4-20). This filter, similar in construction to the primary filter, is used to eliminate the need for strainers at the spray tips. To clean this filter, unscrew the filter housing and remove the screen. Flush the strainer element with water. After cleaning, reassemble filter and check for leaks.



Foam Marker

Filter Maintenance

Air Filters

Clean the primary filter pad, (located behind the louvered openings on the power unit box) after every 100 hours of use. To clean filter, remove from power unit box and wash in warm soapy water or blow dust-free with compressed air.

An additional cylindrical filter is located on the air compressor inlet. Clean filter by removing and blowing compressed air from inside filter. Replace with a new filter if it cannot be cleaned adequately with compressed air.

Water Filter

An in-line water strainer is located under the sprayer frame, in the water line between the rinse tank and power unit box. To clean strainer, unscrew filter halves and flush strainer element with water.

Foam Concentrate Tank Filter

A screen is installed at the outlet of the tank. To clean screen, drain tank, then remove fitting and screen assembly for cleaning.

Foam Head Screens

The foam head screens, located on the outer wings, can be cleaned by disassembling and washing with hot water.

Chemical Inductor

Chemical Container and Inductor Tank Rinsing

⚠ WARNING

- ALWAYS WEAR PERSONAL PROTECTIVE EQUIPMENT WHEN WORKING WITH OR NEAR CHEMICALS. THIS EQUIPMENT INCLUDES, BUT IS NOT LIMITED TO: PROTECTIVE EYE WEAR, GLOVES, SHOES, SOCKS, LONG-SLEEVED SHIRT, AND LONG PANTS. ADDITIONAL PROTECTION MAY BE REQUIRED FOR MANY TYPES OF CHEMICALS.

Both chemical containers and the inductor tank itself can be rinsed by using clean water from the rinse tank. To do so, ensure that the rinse tank is at least 1/2 full, and use the following procedure and refer to (FIG. 4-21):

1. Perform steps 1 through 4 under “Basic Operation” of inductor.
2. Quickly move PUMP INLET SELECTOR valve from <SOLUTION TANK> to <RINSE TANK>.

IMPORTANT

- *It is recommended to work efficiently while the sprayer pump is drawing from the rinse tank, as the rinse water is returned to the solution tank not the rinse tank, and therefore the rinse tank will eventually become empty.*
 - *Do not allow pump to run dry. Pump damage will result.*
3. To rinse a chemical container, place container upside down on rinse nozzle and squeeze handle on rinse wand.
 4. To rinse inductor tank, close lid, open INDUCTOR MIX valve and squeeze rinse wand handle for approximately 10 seconds.
 5. To rinse out jug rinser close lid, and activate jug rinser for approximately 10 seconds.
 6. Close INDUCTOR MIX valve and release rinse wand when rinsing is complete.
 7. Repeat steps 4 and 5 for additional rinsing, if desired.



Chemical Inductor (continued)

Chemical Container and Inductor Tank Rinsing (continued)

8. When inductor tank is empty, close INDUCTOR DRAIN valve, and quickly move PUMP INLET SELECTOR valve from <RINSE TANK> to <SOLUTION TANK> to minimize the amount of rinse water used. (FIG. 4-22)
9. Close INDUCTOR FLOW valve then set AGITATION CONTROL and FILTER PURGE CONTROL to proper settings.
10. Raise tank to storage position.

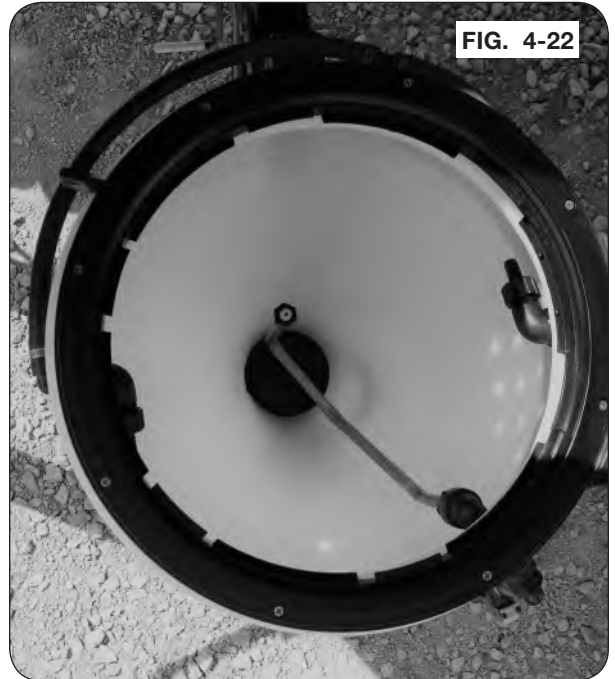

Sprayer Maintenance

DANGER

- ELECTROCUTION WILL CAUSE SERIOUS INJURY OR DEATH. THE SPRAYER IS NOT INSULATED. KEEP AWAY FROM ALL ELECTRICAL LINES AND DEVICES. ELECTROCUTION CAN OCCUR WITHOUT DIRECT CONTACT.



WARNING

- TIPPING OR MOVEMENT OF THE MACHINE CAN CAUSE SERIOUS INJURY OR DEATH. BE SURE MACHINE IS SECURELY BLOCKED.
- EYE PROTECTION AND OTHER APPROPRIATE PERSONAL PROTECTIVE EQUIPMENT MUST BE WORN WHILE SERVICING IMPLEMENT.
- KEEP HANDS CLEAR OF PINCH POINT AREAS.
- MOVING WINGS CAN CAUSE SERIOUS INJURY OR DEATH. KEEP AWAY FROM FOLDING AND UNFOLDING WINGS.
- TIPPING OR MOVEMENT OF SPRAYER CAN CAUSE SERIOUS INJURY OR DEATH. SPRAYER MUST BE HITCHED TO THE TRACTOR BEFORE OPERATING BOOM.
- ALWAYS WEAR PERSONAL PROTECTIVE EQUIPMENT WHEN WORKING WITH OR NEAR CHEMICALS. THIS EQUIPMENT INCLUDES, BUT IS NOT LIMITED TO: PROTECTIVE EYE WEAR, GLOVES, SHOES, SOCKS, LONG-SLEEVED SHIRT, AND LONG PANTS. ADDITIONAL PROTECTION MAY BE REQUIRED FOR MANY TYPES OF CHEMICALS.
- RESIDUAL PRESSURE MAY EXIST IN SPRAYER PLUMBING EVEN WHEN UNIT IS NOT IN USE. RELIEVE PRESSURE BEFORE SERVICING ANY PLUMBING.

CAUTION

- SHARP EDGES ON DRY SPREADER CAN CAUSE SERIOUS INJURY. BE CAREFUL WHEN WORKING AROUND DRY SPREADER.

Seasonal Storage

After season is finished, completely wash machine to remove corrosive fertilizer/chemicals and debris before storing. When using pressure washers, maintain an adequate distance to avoid blasting water into bearings, hydraulic seals or electrical connections.

- Repaint all areas where paint has been removed to keep rust from developing.
- Inspect machine for parts that may need to be replaced so they may be ordered in the off season.
- Lubricate machine at all points outlined in the “Lubrication” section.
- Inspect for damage or worn parts, replace before next season.
- Replace all worn, torn or faded decals and reflectors.
- Ensure ladder is latched and in storage position.
- Store the sprayer inside, away from animals.
- Check hydraulic hoses for weather cracks and replace accordingly.
- After any period of unused time, unit should be operated to check function of hydraulic system.

Winterizing

Sprayer Plumbing

WARNING

- ALWAYS WEAR PERSONAL PROTECTIVE EQUIPMENT WHEN WORKING WITH OR NEAR CHEMICALS. THIS EQUIPMENT INCLUDES, BUT IS NOT LIMITED TO: PROTECTIVE EYE WEAR, GLOVES, SHOES, SOCKS, LONG-SLEEVED SHIRT, AND LONG PANTS. ADDITIONAL PROTECTION MAY BE REQUIRED FOR MANY TYPES OF CHEMICALS.

IMPORTANT

- Do not allow pump to run dry. Pump damage will result.

Before storing the sprayer in freezing climates, perform the following winterizing procedure:

NOTE: If unit is equipped with an optional chemical injection system, rinse water supplied from the main sprayer pump is required.

1. Perform a complete system rinse using procedure in the OPERATION section of this manual.
2. Wash the sprayer thoroughly inside and out with a high-pressure washer.
3. Remove as much water from solution and rinse tanks as possible. Close drain valve on solution tank after draining.
4. Pour approximately 50 gallons of R.V. antifreeze into rinse tank.
5. Perform a tank rinse, using procedure in the OPERATION section of this manual.
6. Run the pump with the following valve settings to flush antifreeze solution throughout system. Run the system for 1 minute alternating between discharging solution from the boom and not discharging solution from the boom in 10–15 second intervals.

NOTE: The rinse tank will continuously lose product while the pump is engaged due to recirculation system.

Valve Settings:

Pump Inlet = Rinse
Agitation Control = Fully Open
Filter Purge = Fully Open
Pump Outlet = Boom

7. Loosen diaphragm caps on nozzle bodies to relieve pressure and allow excess antifreeze to drain from boom.
8. Ensure manual recirculating valve handle is in OFF / CLOSED position. (FIG. 4-23)

(Continued on next page)

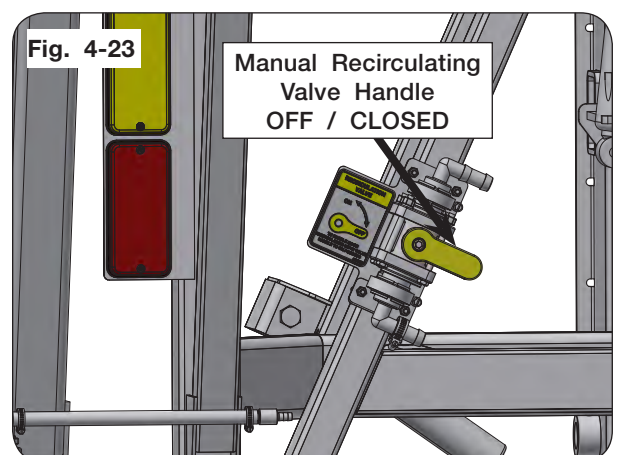

Fig. 4-23

Manual Recirculating
Valve Handle
OFF / CLOSED

Winterizing (continued)

Foam Marker (Optional)

The liquid lines and tank must be drained completely prior to storage. If liquid in the system is allowed to freeze, several components may be damaged. Use the following procedure to winterize the foam marking system:

1. Drain the foam concentrate tank and line by disconnecting at the bulkhead connector on the power unit box. Disconnect the line by pushing the hose fully into the fitting. Then while pushing the inner collar firmly onto the connector, pull the hose from the connector.
2. Flush out concentrate tank with warm water.
3. Reconnect hose by pushing fully into bulkhead connector. Pull carefully on hose near connector to verify that proper connection has been made.
4. Add approximately ½ pint of RV antifreeze solution to concentrate tank.
5. Disconnect liquid line at rinse tank.
6. Attach hose to a suitable temporary container. Fill container with approximately 1 pint of RV antifreeze solution.
7. Run foamer unit until antifreeze solution from temporary container is empty.
8. Reconnect liquid line to rinse tank.

Chemical Inductor (Optional)

1. Refer to the rinsing procedure in this section.

Gauge Panel

1. Uncouple tubes from gauge panel. (FIG. 4-24 & 4-25)
2. Allow tubes to fully drain.

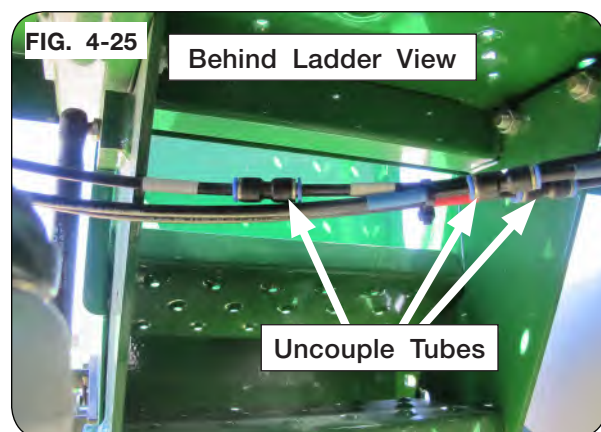
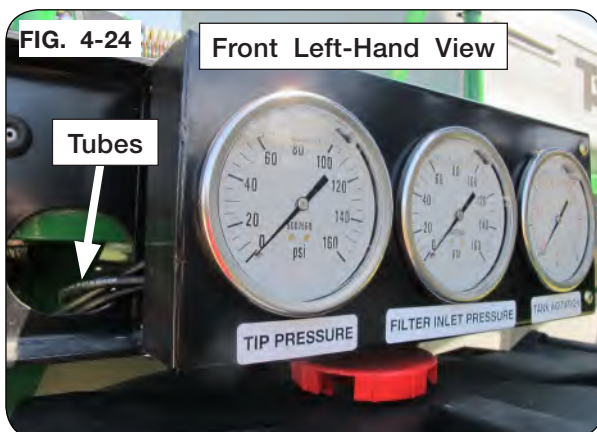

Schematics - Sprayer Chemical

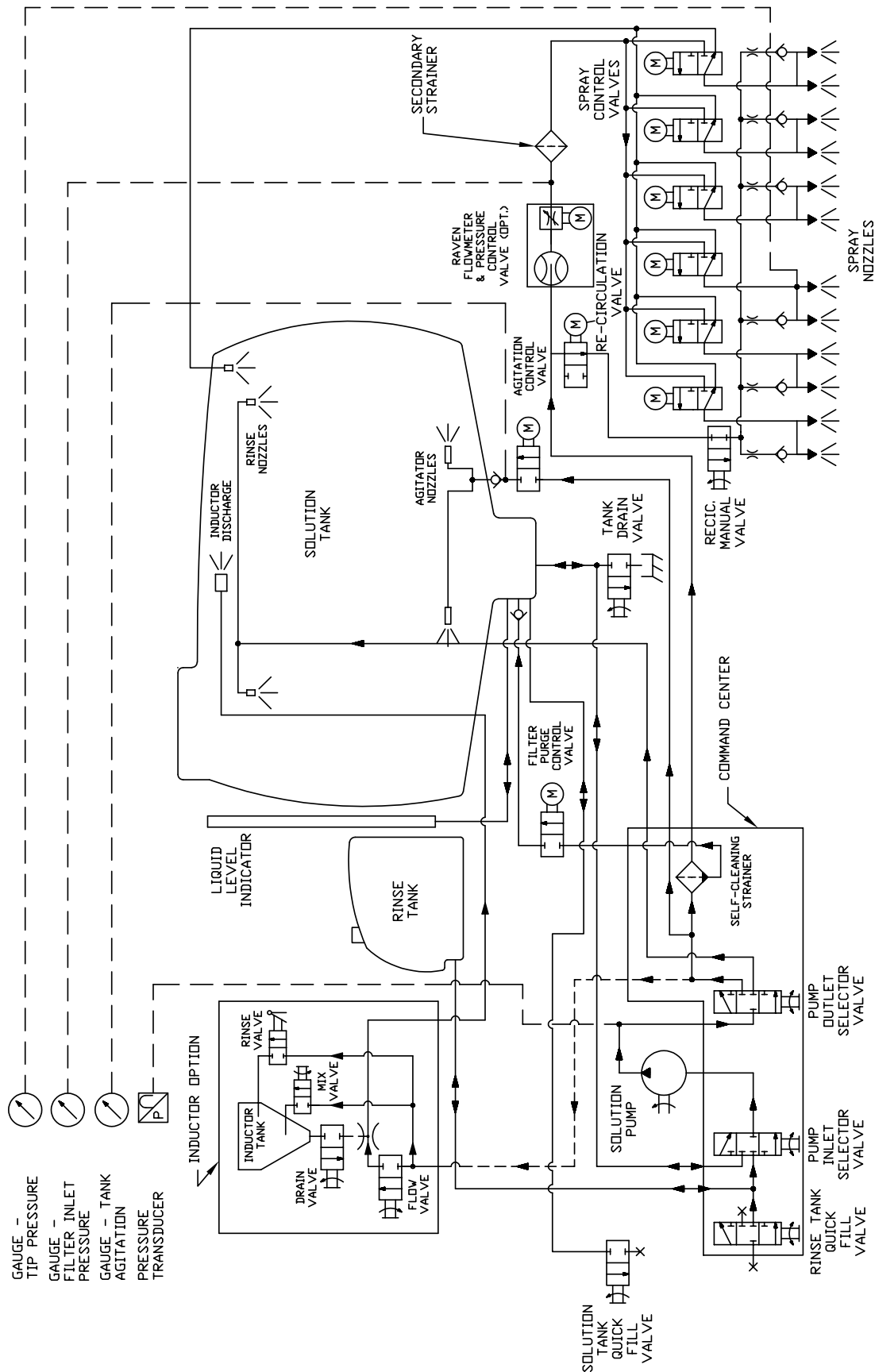

Schematics - Hydraulic (60' Boom)

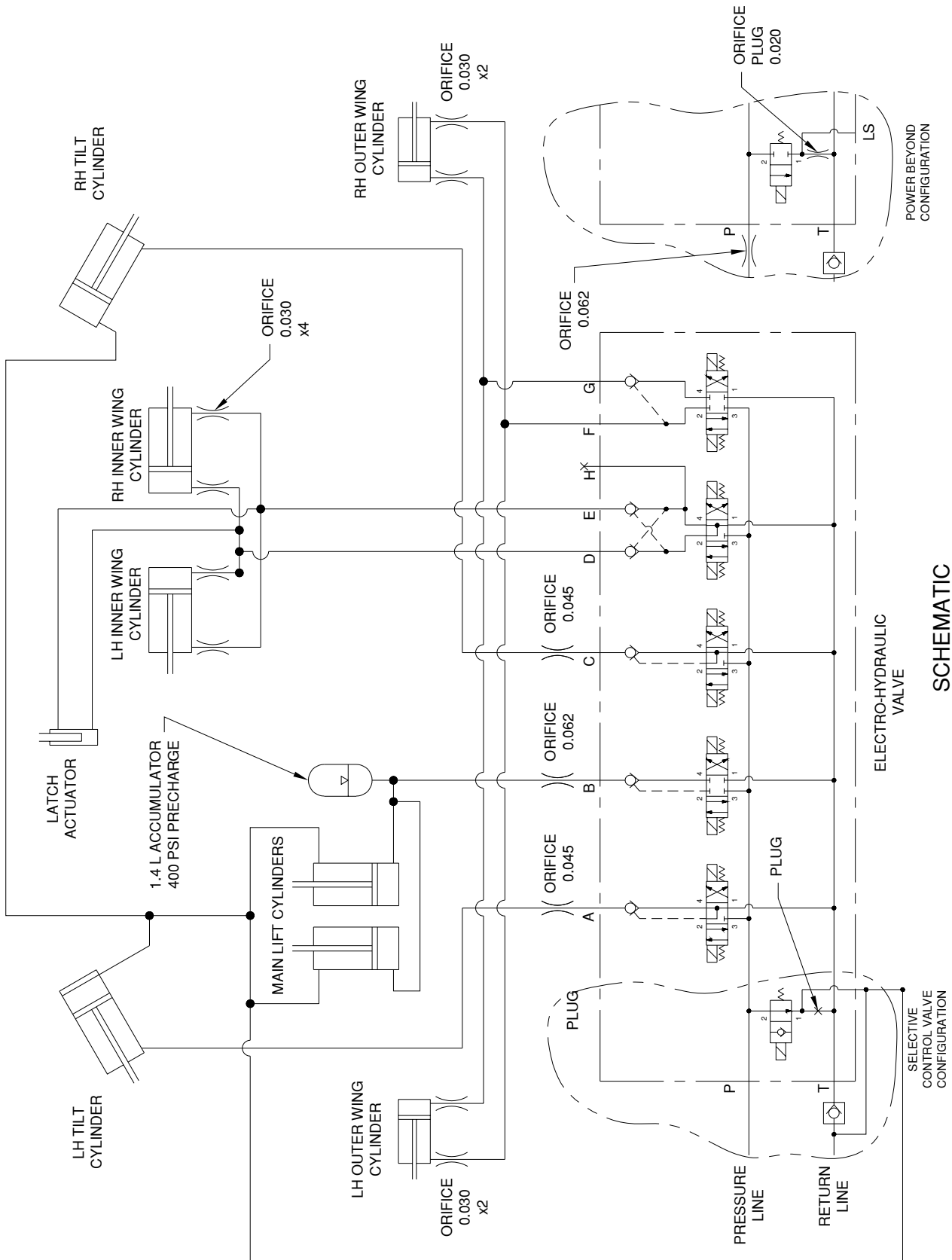

SCHEMATIC
60 FT. BOOM HYDRAULIC

Schematics - Hydraulic (80/90' Boom)

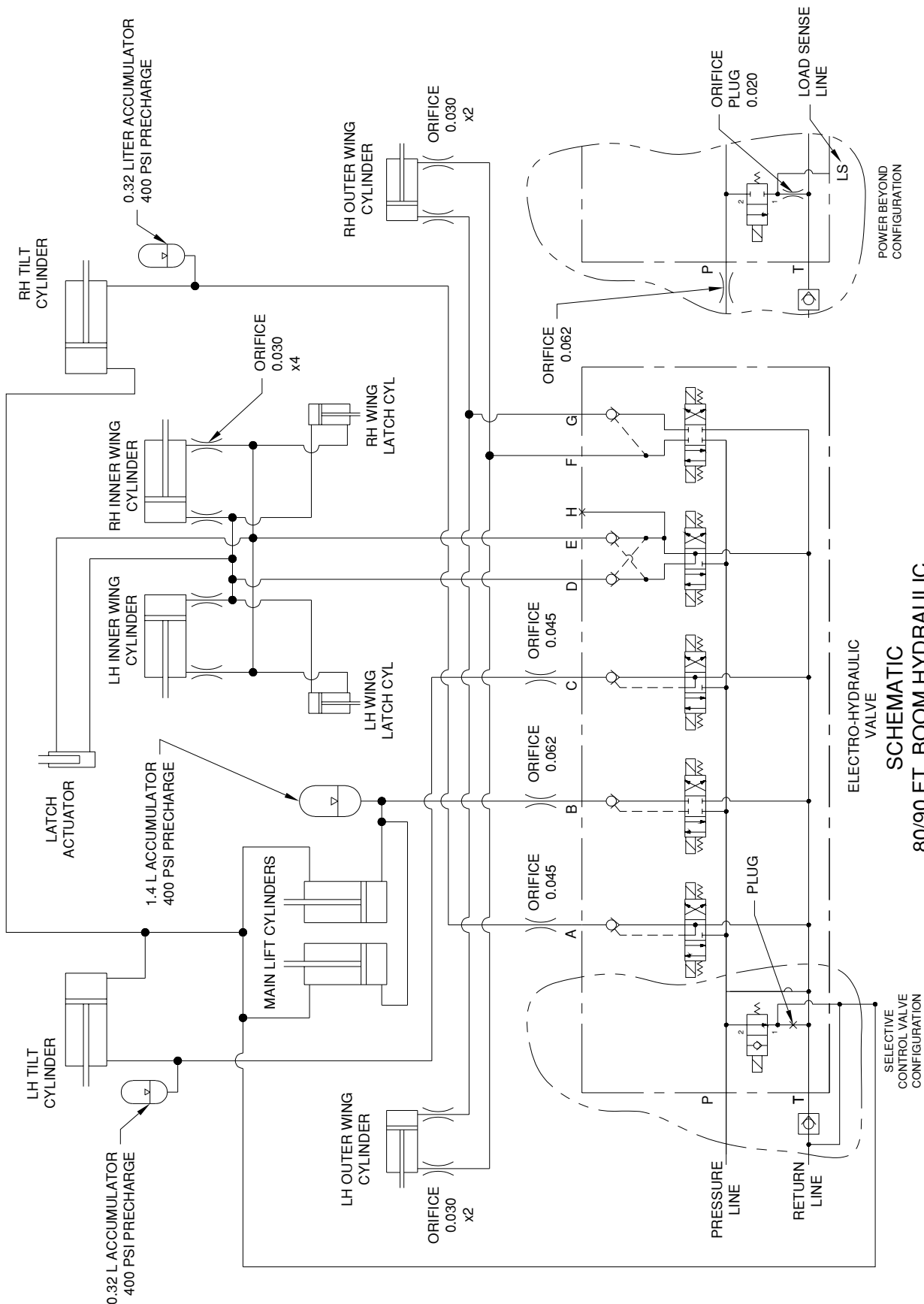

SCHEMATIC
80/90 FT. BOOM HYDRAULIC

Schematics - Hydraulic (120/132' Boom)

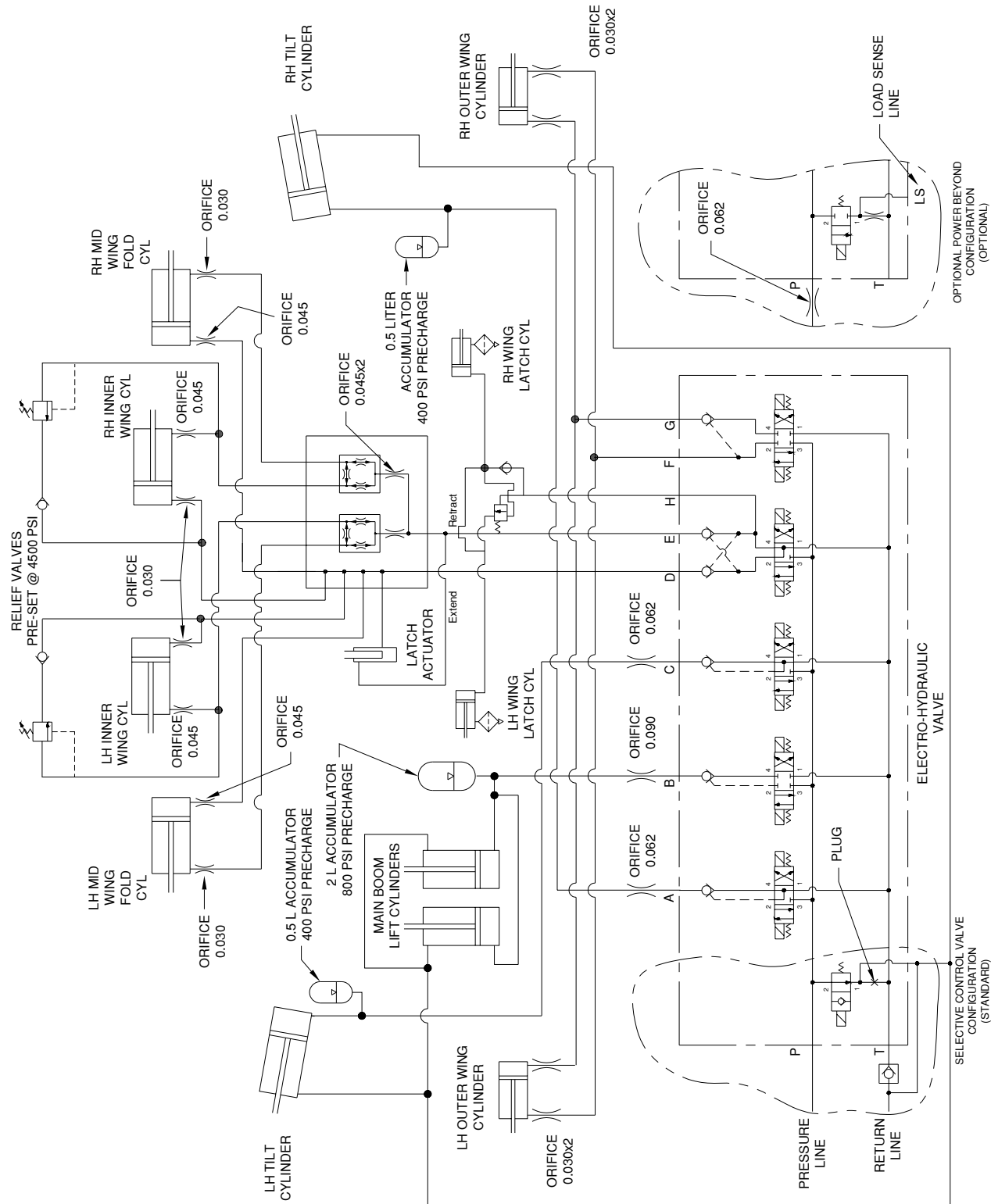

SCHEMATIC
120/132 FT. BOOM HYDRAULIC

Schematic — Electrical — Wireless Controller System

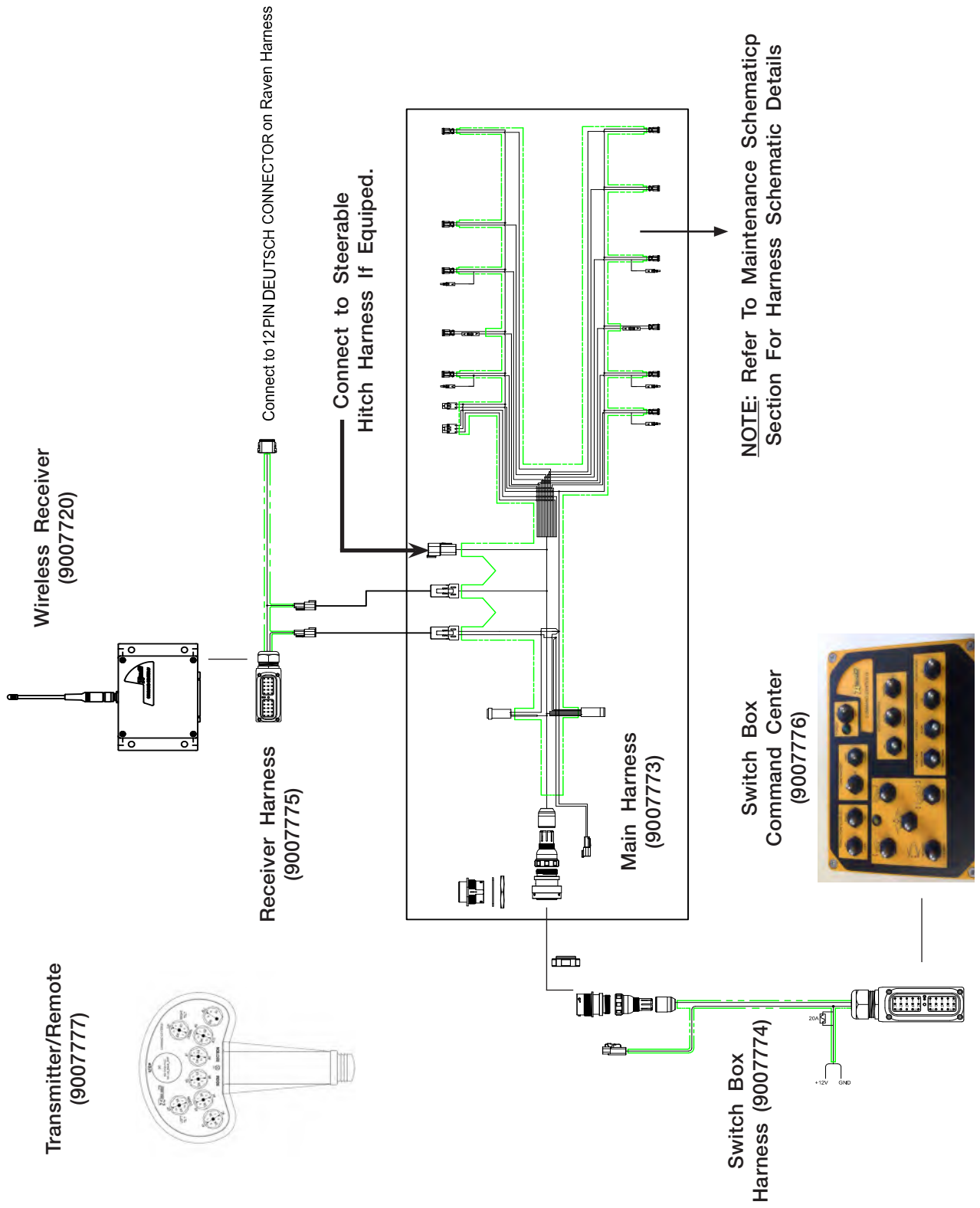

Electrical System Schematic

LIGHTING WIRES

- White -- Ground
- Green -- Right amber flashing lamp
- Yellow -- Left amber flashing lamp
- Brown -- Tail light
- Black -- Optional Work Lights
- Red -- Brake Lights
- Blue -- **Not Used**

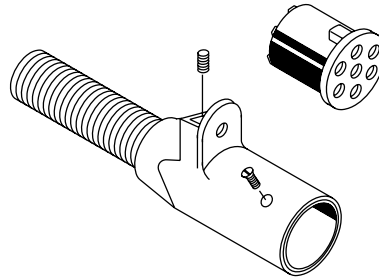

92450

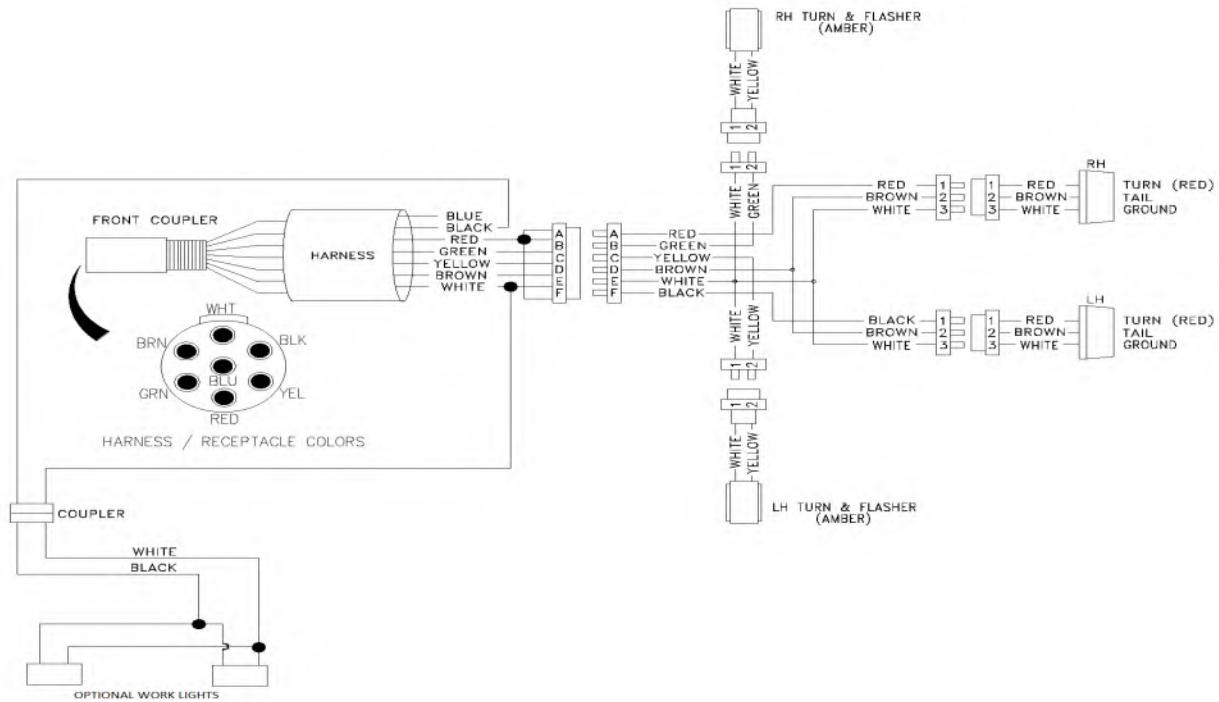

Schematic — Recirculation Valve Cable (9010214)

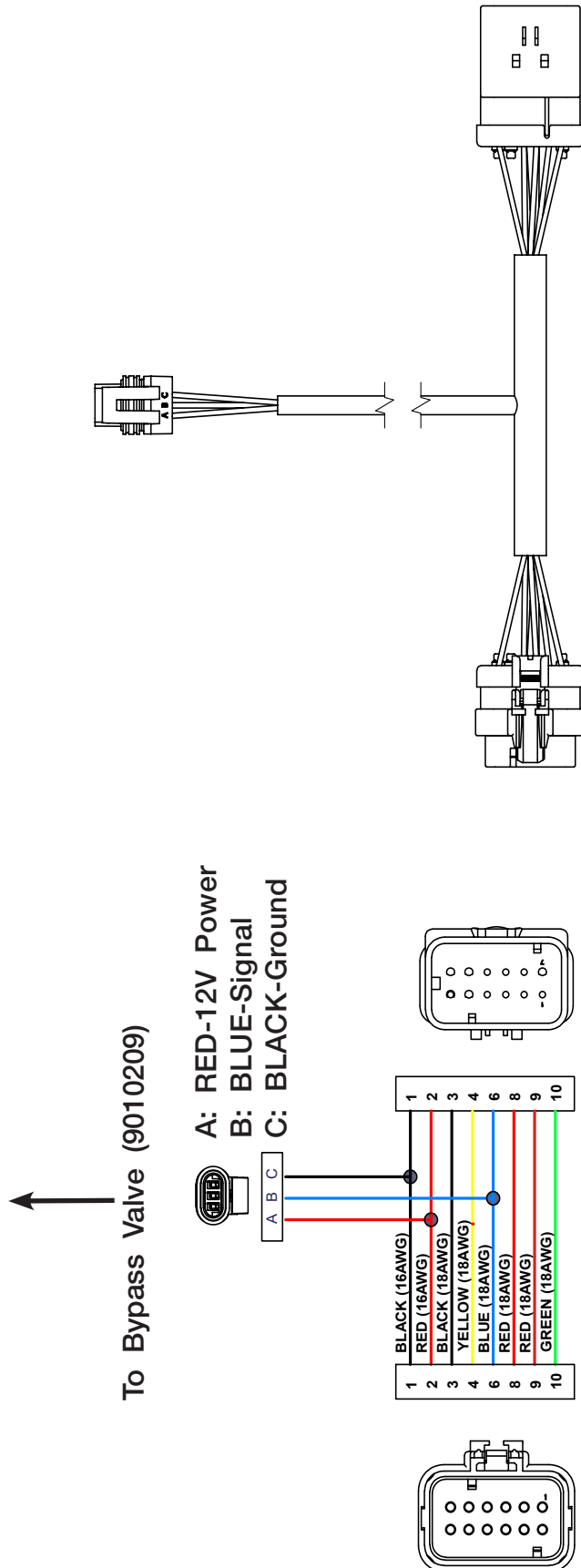

Schematic — Electrical — Main Harness (9007773)

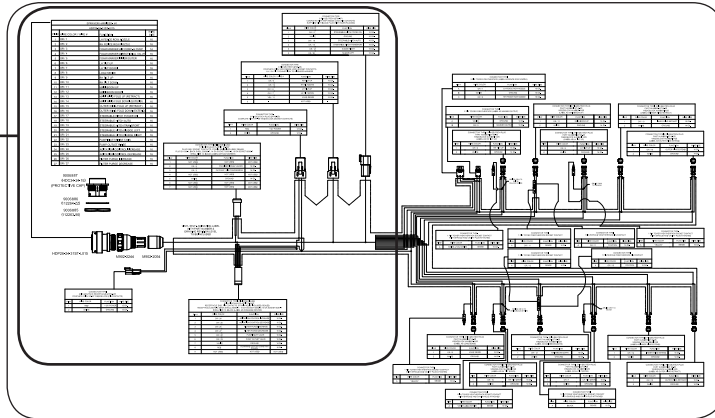

SPRAYER HARNESS - #1 HDP26-24-31ST-4.015			
PIN #	WIRE COLOR / WIRE #	FUNCTION	WIRE SIZE
1	OR / 1	LH FENCE ROW NOZZLE	16
2	OR / 2	RH FENCE ROW NOZZLE	16
3	OR / 3	FOAM MARKER AIR COMP. & PUMP	14
4	OR / 4	FOAM MARKER DIRECTIONAL VALVE	16
5	OR / 5	FOAM MARKER INNER/OUTER	16
6	OR / 6	LH TILT UP	16
7	OR / 7	LH TILT DOWN	16
8	OR / 8	LOAD SENSE	16
9	OR / 9	RH TILT UP	16
10	OR / 10	RH TILT DOWN	16
11	OR / 11	MAIN BOOM UP	16
12	OR / 12	MAIN BOOM DOWN	16
13	OR / 13	MAIN WING FOLD UP (RETRACT)	16
14	OR / 14	MAIN WING FOLD DOWN (EXTEND)	16
15	OR / 15	OUTER WING FOLD UP (RETRACT)	16
16	OR / 16	OUTER WING FOLD DOWN (EXTEND)	16
17	OR / 17	STEERABLE HITCH POWER ON	16
18	OR / 18	STEERABLE HITCH AUTO	16
19	OR / 19	STEERABLE HITCH TRANSPORT	16
20	OR / 20	STEERABLE HITCH NUJGE LEFT	16
21	OR / 21	STEERABLE HITCH NUJGE RIGHT	16
22	OR / 22	PUMP INLET RINSE TANK	16
23	OR / 23	PUMP OUTLET RINSE	16
24	OR / 24	AGITATION CONTROL INCREASE	16
25	OR / 25	AGITATION CONTROL DECREASE	16
26	OR / 26	FILTER PURGE INCREASE	16
27	OR / 27	FILTER PURGE DECREASE	16

CONNECTOR TYPE 6 PIN DEUTSCH (D704-4P) COMPLETE WITH WP WEDGE LOCK (PIN CONTACTS) SUPPLIED WITH BLANK PLUG WITH HOLES PLUGGED			
PIN #	WIRE COLOR	FUNCTION	WIRE SIZE
1	OR / 17	STEERABLE HITCH POWER ON	16 GA.
2	WHITE	GROUND	16 GA.
3	OR / 18	STEERABLE HITCH AUTO	16 GA.
4	OR / 19	STEERABLE HITCH TRANSPORT	16 GA.
5	OR / 21	NUJGE RIGHT	16 GA.
6	OR / 20	NUJGE LEFT	16 GA.

CONNECTOR TYPE 6 PIN DEUTSCH (D704-6S) COMPLETE WITH WP WEDGE LOCK (SOCKET CONTACTS) LH / RH TILT CONNECTION TO WIRELESS HARNESS			
PIN #	WIRE COLOR / WIRE #	FUNCTION	WIRE SIZE
1	OR / 9	RH TILT UP	16 GA.
2	OR / 10	RH TILT DOWN	16 GA.
3	OR / 6	LH TILT UP	16 GA.
4	OR / 7	LH TILT DOWN	16 GA.
5	YEL / 11	LOAD SENSE	16 GA.
6	-	NOT USED	-

CONNECTOR TYPE 2 PIN DEUTSCH PLUG (D704-2S) COMPLETE WITH WP WEDGE LOCK (SOCKET CONTACTS)			
PIN #	WIRE COLOR	FUNCTION	WIRE SIZE
1	RED	+12V POWER	12 GA.
2	WHITE	GROUND	12 GA.

CONNECTOR TYPE: (SILICONE FILLED) 7 PIN CIRCULAR PLASTIC TE-AMP PLUG END, SOCKET CONTACTS, STRAIN RELIEF INCLUDED, SEALED PLUG 211399-1, BACK SHELL 20666-7, 14 GA SOCKET 66513-4, 16 GA SOCKET 66367-7 SHELL SIZE 13, BLACK (LABEL AS FOAM MARKER)			
PIN #	WIRE COLOR	FUNCTION	WIRE SIZE
1	NOT USED	NOT USED	NOT USED
2	OR / 4	FM DIRECTIONAL VALVES	16 GA.
3	OR / 3	FM PUMP / AIR COMPRESSOR	14 GA.
4	NOT USED	NOT USED	NOT USED
5	WHITE	GROUND	14 GA.
6	NOT USED	NOT USED	NOT USED
7	NOT USED	NOT USED	NOT USED

9006887
(HDC34-24-1E)
(PROTECTIVE CAP)

9006886
(112264-ZZ)

9006885
(112263-90)

HDP26-24-31ST-L015

M902-2244

M902-2054

VINYL SELF-LAMINATING LABEL
WITH PART NUMBER &
DRAWING REVISION LEVEL
TO BE INCLUDED

CONNECTOR TYPE: 2 PIN DEUTSCH RECEPTACLE (D704-2P) COMPLETE WITH WP WEDGE LOCK (PIN CONTACTS)			
PIN #	WIRE COLOR	FUNCTION	WIRE SIZE
1	RED	+12V POWER	12 GA.
2	WHITE	GROUND	12 GA.

CONNECTOR TYPE: (SILICONE FILLED) 8 PIN CIRCULAR PLASTIC TE-AMP RECEPTACLE END, PIN CONTACTS, STRAIN RELIEF INCLUDED, SEALED RECEPTACLE 20675-2, BACK SHELL 20666-7, 14 GA SOCKET 66524, 16 GA SOCKET 66367-7 SHELL SIZE 13, BLACK (LABEL AS COMMAND CENTER)			
PIN #	WIRE COLOR	FUNCTION	WIRE SIZE
1	OR / 24	AGITATION CONTROL INCREASE	16 GA.
2	OR / 25	AGITATION CONTROL DECREASE	16 GA.
3	OR / 26	FILTER PURGE INCREASE	16 GA.
4	OR / 27	FILTER PURGE DECREASE	16 GA.
5	OR / 22	PUMP INLET VALVE	16 GA.
6	OR / 23	PUMP OUTLET VALVE	16 GA.
7	WHITE	GROUND	14 GA.
8	RED	COMMAND CENTER CONSTANT POWER	16 GA.
9	NOT USED	NOT USED	NOT USED

Schematic — Electrical — Main Harness (9007773) (continued)

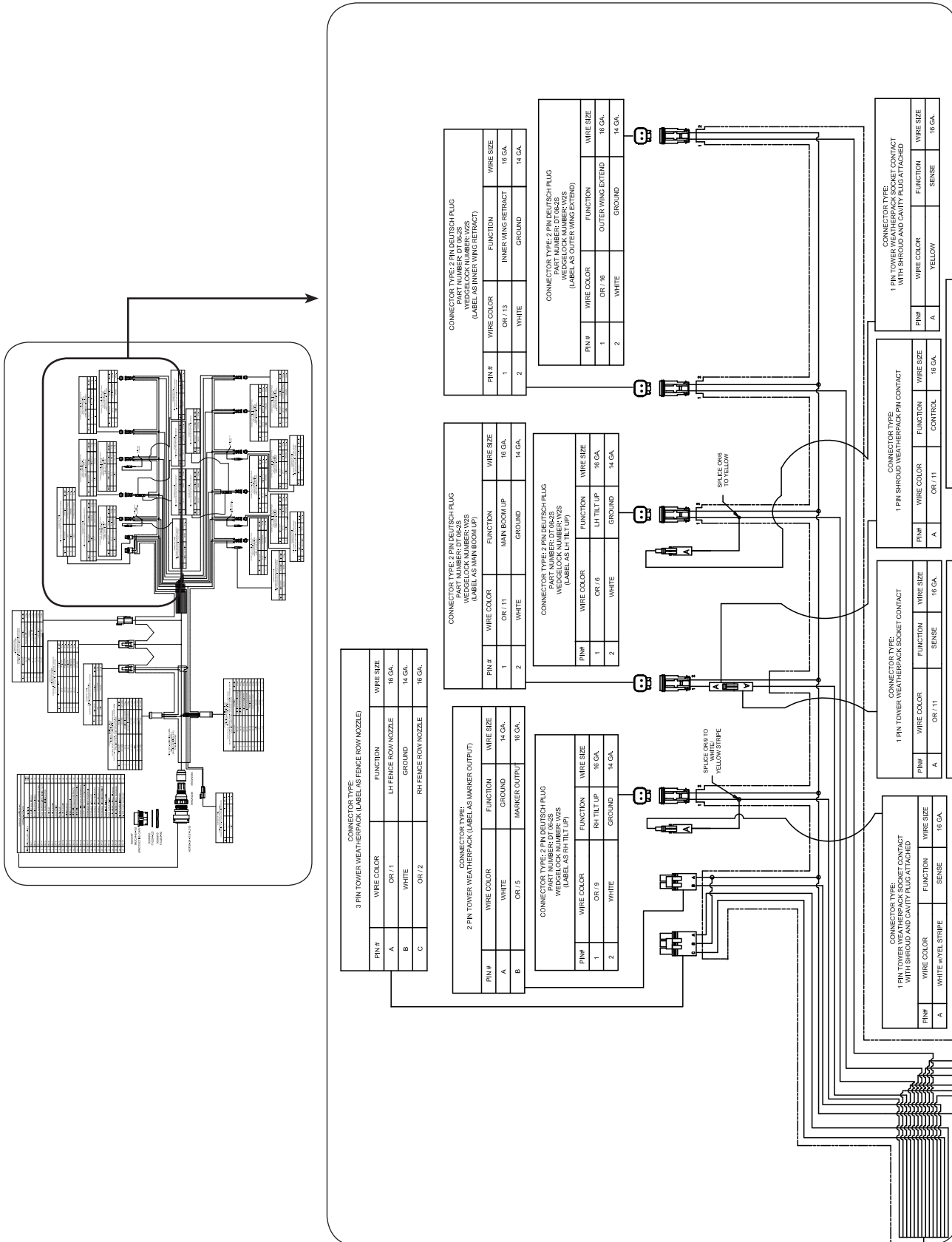

Schematic — Electrical — Main Harness (9007773) (continued)

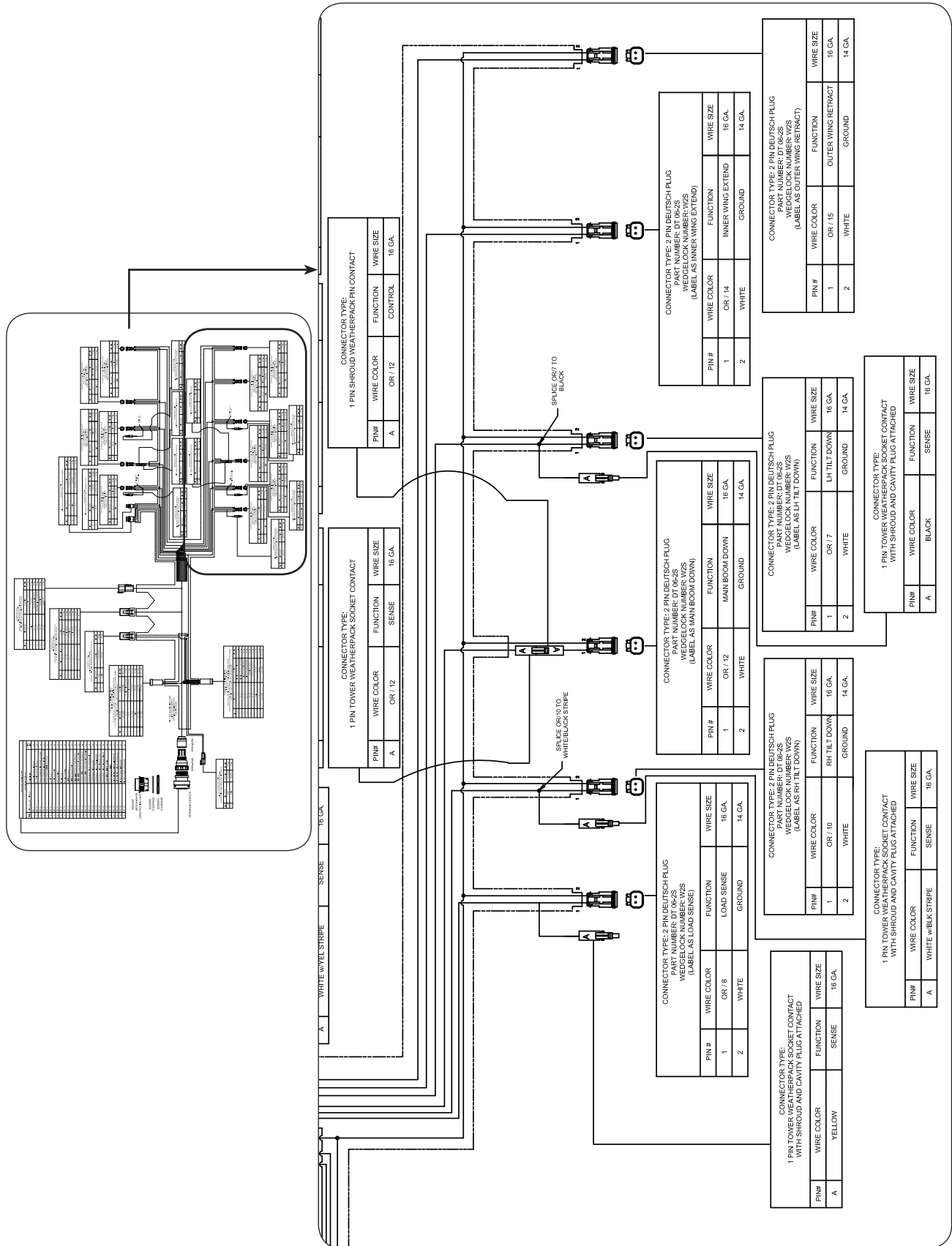

Schematic — Electrical — Receiver Harness (9007775)

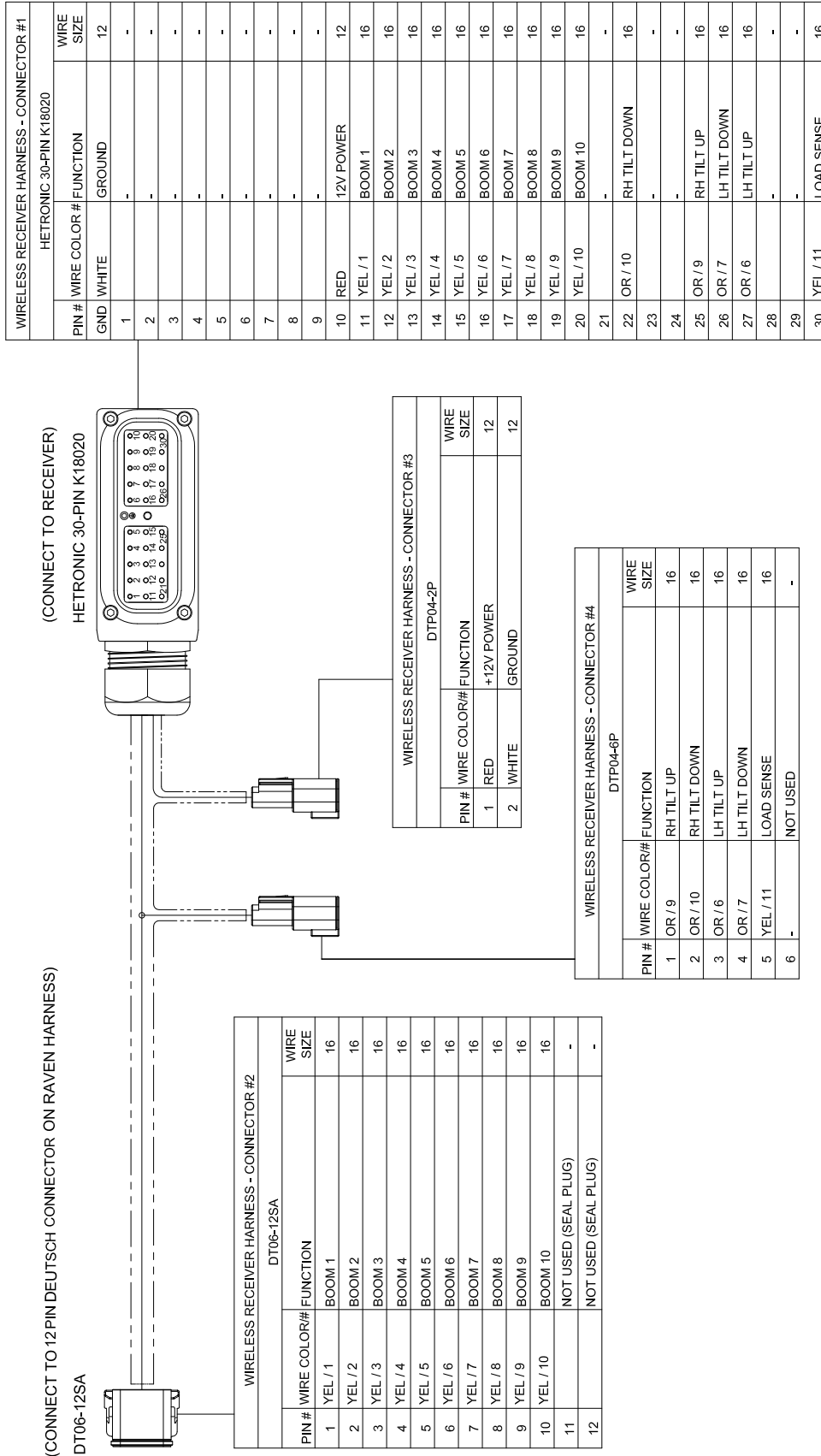

Schematic — Electrical — Switch Box Harness (9007774)

SWITCH CONSOLE HARNESS - #3			WIRE SIZE
HETRONIC 30-PIN K18020			
PIN #	WIRE COLOR#/FUNCTION		
1	OR / 1	LH FENCE ROW NOZZLE UP	16
2	OR / 2	RH FENCE ROW NOZZLE UP	16
3	OR / 3	FOAM MARKER AIR COMP. & PUMP	14
4	OR / 4	FOAM MARKER DIRECTIONAL VALVE	16
5	OR / 5	FOAM MARKER INNER/OUTER LEFT	16
6	OR / 6	LH TILT UP	16
7	OR / 7	LH TILT DOWN	16
8	OR / 8	LOAD SENSE	16
9	OR / 9	RH TILT UP	16
10	OR / 10	RH TILT DOWN	16
11	OR / 11	MAIN BOOM LIFT UP	16
12	OR / 12	MAIN BOOM LIFT DOWN	16
13	OR / 13	MAIN WING FOLD UP (RETRACT)	16
14	OR / 14	MAIN WING FOLD DOWN (EXTEND)	16
15	OR / 15	OUTER WING FOLD UP (RETRACT)	16
16	OR / 16	OUTER WING FOLD DOWN (EXTEND)	16
17	OR / 17	STEERABLE HITCH POWER ON	16
18	OR / 18	STEERABLE HITCH AUTO	16
19	OR / 19	STEERABLE HITCH TRANSPORT	16
20	OR / 20	STEERABLE HITCH NUDDGE LEFT	16
21	OR / 21	STEERABLE HITCH NUDDGE RIGHT	16
22	OR / 22	PUMP INLET RINSE TANK	16
23	OR / 23	PUMP OUTLET RINSE	16
24	OR / 24	AGITATION CONTROL INCREASE	16
25	OR / 25	AGITATION CONTROL DECREASE	16
26	OR / 26	FILTER PURGE INCREASE	16
27	OR / 27	FILTER PURGE DECREASE	16
28	RED	12V POWER	12
29	RED	12V POWER	12
30	RED	12V POWER	12
G	WHITE	GROUND	12

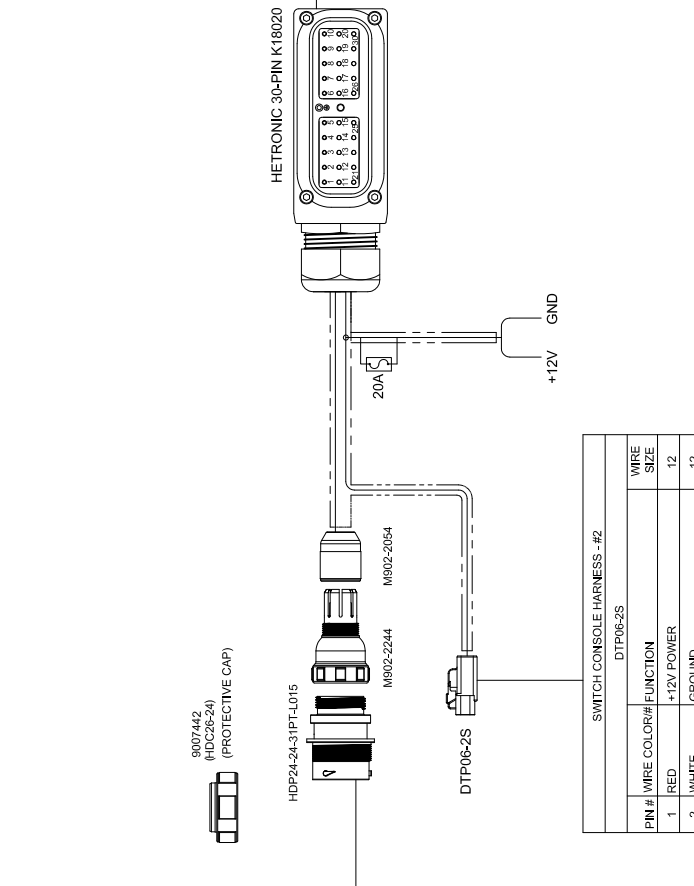

SWITCH CONSOLE HARNESS - #1			WIRE SIZE
HDP24-24-31PT-L015			
PIN #	WIRE COLOR#/FUNCTION		
1	OR / 1	LH FENCE ROW NOZZLE UP	16
2	OR / 2	RH FENCE ROW NOZZLE UP	16
3	OR / 3	FOAM MARKER AIR COMP. & PUMP	14
4	OR / 4	FOAM MARKER DIRECTIONAL VALVE	16
5	OR / 5	FOAM MARKER INNER/OUTER LEFT	16
6	OR / 6	LH TILT UP	16
7	OR / 7	LH TILT DOWN	16
8	OR / 8	LOAD SENSE	16
9	OR / 9	RH TILT UP	16
10	OR / 10	RH TILT DOWN	16
11	OR / 11	MAIN BOOM LIFT UP	16
12	OR / 12	MAIN BOOM LIFT DOWN	16
13	OR / 13	MAIN WING FOLD UP (RETRACT)	16
14	OR / 14	MAIN WING FOLD DOWN (EXTEND)	16
15	OR / 15	OUTER WING FOLD UP (RETRACT)	16
16	OR / 16	OUTER WING FOLD DOWN (EXTEND)	16
17	OR / 17	STEERABLE HITCH POWER ON	16
18	OR / 18	STEERABLE HITCH AUTO	16
19	OR / 19	STEERABLE HITCH TRANSPORT	16
20	OR / 20	STEERABLE HITCH NUDDGE LEFT	16
21	OR / 21	STEERABLE HITCH NUDDGE RIGHT	16
22	OR / 22	PUMP INLET RINSE TANK	16
23	OR / 23	PUMP OUTLET RINSE	16
24	OR / 24	AGITATION CONTROL INCREASE	16
25	OR / 25	AGITATION CONTROL DECREASE	16
26	OR / 26	FILTER PURGE INCREASE	16
27	OR / 27	FILTER PURGE DECREASE	16
28	WHITE	GROUND	14

SWITCH CONSOLE HARNESS - #2			WIRE SIZE
DTP06-2S			
PIN #	WIRE COLOR#/FUNCTION		
1	RED	+12V POWER	12
2	WHITE	GROUND	12

Wheel, Hub and Spindle Disassembly and Assembly

WARNING

- TIPPING OR MOVEMENT OF THE MACHINE CAN CAUSE SERIOUS INJURY OR DEATH. BE SURE MACHINE IS SECURELY BLOCKED.
- FALLING OBJECTS CAN CAUSE SERIOUS INJURY OR DEATH. DO NOT WORK UNDER THE MACHINE AT ANY TIME WHILE BEING HOISTED. BE SURE ALL LIFTING DEVICES AND SUPPORTS ARE RATED FOR THE LOADS BEING HOISTED. THESE ASSEMBLY INSTRUCTIONS WILL REQUIRE SAFE LIFTING DEVICES UP TO 8,000 LBS. SPECIFIC LOAD RATINGS FOR INDIVIDUAL LOADS WILL BE GIVEN AT THE APPROPRIATE TIME IN THE INSTRUCTIONS.
- EYE PROTECTION AND OTHER APPROPRIATE PERSONAL PROTECTIVE EQUIPMENT MUST BE WORN WHILE SERVICING IMPLEMENT.
- KEEP HANDS CLEAR OF PINCH POINT AREAS.

CAUTION

- IMPROPERLY TORQUED WHEEL NUTS/BOLTS CAN CAUSE A LOSS OF IMPLEMENT CONTROL AND MACHINE DAMAGE. TORQUE WHEEL NUTS/BOLTS TO VALUES IN TABLE. CHECK TORQUE BEFORE USE, AFTER ONE HOUR OF UNLOADED USE OR AFTER FIRST LOAD, AND EACH LOAD UNTIL WHEEL NUTS/BOLTS MAINTAIN TORQUE VALUE. CHECK TORQUE EVERY 10 HOURS OF USE THERE-AFTER. AFTER EACH WHEEL REMOVAL START TORQUE PROCESS FROM BEGINNING. WARRANTY DOES NOT COVER FAILURES CAUSED BY IMPROPERLY TORQUED WHEEL NUTS/BOLTS.

IMPORTANT

- *Remove only one wheel and tire from a side at any given time in the following procedure.*

1. Park the empty machine on a firm, level surface. Block the machine to keep it from moving. Set the tractor's parking brake, shut off engine, remove the ignition key, and disconnect hydraulics from the vehicle to the spreader.



2. With machine empty, use a safe lifting device rated for 8,000 lbs. to support the weight of the machine. Place the lifting device under the axle closest to the tire.
3. Use a safe lifting device rated for 1,500 lbs. to support the wheel and tire.

NOTE: For straddle duals, first remove the outer wheel and tire.

WARNING

- ON UNITS WITH DUAL WHEELS, INNER WHEEL AND TIRE MAY FALL FROM HUB CAUSING SERIOUS INJURY OR DEATH. ALWAYS SUPPORT INNER WHEEL WHEN REMOVING OUTER WHEEL AND/OR WHEEL EXTENSION.
4. If only changing wheel and tire, skip to Step 8; otherwise continue with Step 4.

Remove the hardware retaining the hubcap. Next, remove the hubcap, gasket, capscrew, castle nut and spindle washer. Remove hub with bearings from old spindle using a 200 lb. safe lifting device.

Wheel, Hub and Spindle Disassembly and Assembly (continued)

5. Inspect the spindle and replace if necessary. If spindle does not need to be replaced, skip to Step 6; otherwise continue with Step 5.

Remove the capscrew and lock nut that retain the spindle to the axle. Using a safe lifting device rated for 200 lbs., replace the old spindle with a new spindle. Coat axle contact length of spindle shaft with anti-seize lubricant prior to installation. Reuse old hardware to retain spindle to axle. Tighten as outlined in MAINTENANCE section.

6. Remove seal and inspect bearings, spindle washer, castle nut and capscrew. Replace if necessary. Pack both bearings with approved grease and reinstall inner bearing. Install new seal in hub with garter spring facing the hub by tapping on flat plate that completely covers seal while driving it square to hub. (FIG. 4-26) Install until flush with back face of hub. Using a safe lifting device rated for 200 lbs., install hub assembly onto spindle. Install outer bearing, spindle washer and castle nut.

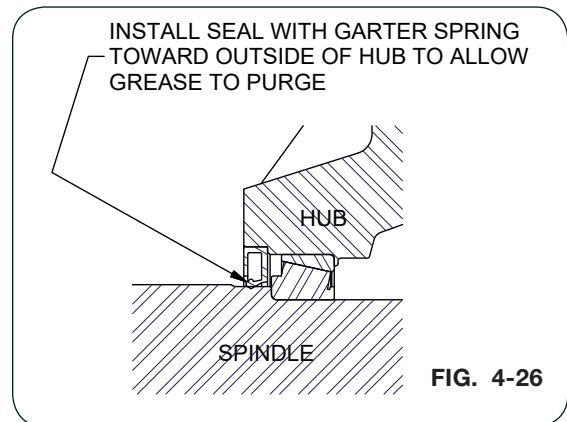

7. Slowly tighten castle nut while spinning the hub until drag causes the hub to stop freely spinning. Do not use an impact! Turn castle nut counterclockwise until the hole in the spindle aligns with the next notch in castle nut. Hub should spin smoothly with little drag and no end play. If play exists, tighten to next notch of castle nut. If drag exists, then back castle nut to next notch of castle nut. Spin and check again. Install cotter pin. Clean face for hub cap gasket and install gasket, grease filled hub cap and retain hubcap with hardware removed. Tighten hubcap hardware in alternating pattern.
8. Attach the wheel(s) and tire(s) to the hub using the same rated safe lifting device for removal. Tighten wheel nuts to appropriate requirements and recheck as outlined in the “Wheel and Tires” section of this manual.
9. Raise sprayer, remove safe load holding devices and lower tire to the ground.

Wheels and Tires

Wheel Nut Torque Requirements

CAUTION

- IMPROPERLY TORQUED WHEEL NUTS/BOLTS CAN CAUSE A LOSS OF IMPLEMENT CONTROL AND MACHINE DAMAGE. TORQUE WHEEL NUTS/BOLTS TO VALUES IN TABLE. CHECK TORQUE BEFORE USE, AFTER ONE HOUR OF UNLOADED USE OR AFTER FIRST LOAD, AND EACH LOAD UNTIL WHEEL NUTS/BOLTS MAINTAIN TORQUE VALUE. CHECK TORQUE EVERY 10 HOURS OF USE THEREAFTER. AFTER EACH WHEEL REMOVAL START TORQUE PROCESS FROM BEGINNING. WARRANTY DOES NOT COVER FAILURES CAUSED BY IMPROPERLY TORQUED WHEEL NUTS/BOLTS.

Failure to check torque before first load may damage wheel nut/bolt seats. Once seats are damaged, it will become impossible to keep nuts/bolts tight. Tighten nuts/bolts to applicable torque values shown in table. Start all nuts/bolts by hand to prevent cross threading. Torque nuts/bolts in the recommended sequence as shown in Diagram 1.

NOTE: Do not use anti-seize on wheel hardware.

WHEEL HARDWARE	
SIZE	FOOT-POUNDS
7/8-14 (UNF)	440 ft.-lbs.
M22 x 2.5	500 ft.-lbs.

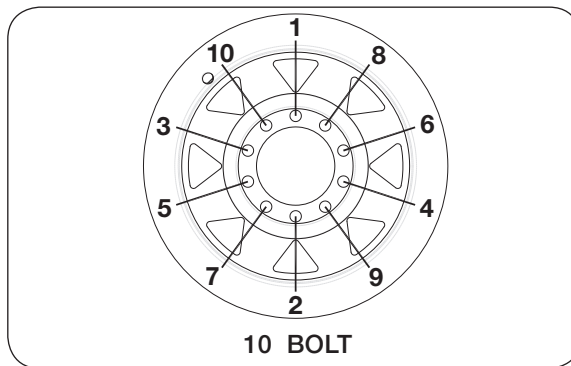

10 BOLT

DIAGRAM 1

Wheels and Tires (continued)

Tire Pressure

The following is to be used as a general guide for tire inflation and figures can vary depending on specific brand of tire used. It is important that tires are inspected after unit is loaded. Start with minimum pressure. The tire should stand up with no side-wall buckling or distress as tire rolls. Record the pressure needed to support the full load and maintain this pressure to achieve proper tire life. Do not exceed maximum recommended tire pressure. Each tire must be inflated to 35 PSI max to seat the beads, deflated to 5-10 PSI, then reinflated to recommended minimum pressure.

Tire Pressure for Top Air Sprayers			
Tire Make	Tire Size	Load Index / Ply	
		Rating	Max PSI
Firestone	480/80R42 R-1	151 A8	36
Goodyear	320/105R54 R-1W	166 A8	75
Mitas	320/95R46 R-1W	152 A8	58
	320/90R50 R-1W	150 A8	52
	320/105R54 R-1W	169 D	58
	380/90R46 R-1W	159 A8	58
	380/90R54 R-1W	152 A8	35
	480/80R50 R-1W	159 A8	35
	650/65R42 R-1W	168 A8	44

Tire Warranty

For questions regarding new tire warranty, please contact your local original equipment tire dealer. Used tires carry no warranty. Following are phone numbers and Websites for your convenience:

Firestone www.firestoneag.com
Phone 800-847-3364

Titan www.titan-intl.com
or Phone 800-USA-BEAR
Goodyear Fax 515-265-9301

Continental/Mitas www.mitas-tires.com
Phone 704-542-3422
Fax 704-542-3474

Tracks

Track Warranty

For questions regarding new track warranty, please contact your local dealer or call Unverferth Manufacturing @ 1-800-264-4580. Used tracks carry no warranty.

Complete English and Metric Torque Chart

Capscrews - Grade 5

NOTE:

- Grade 5 capscrews can be identified by three radial dashes on the head.
- For wheel torque requirements, refer to Wheels and Tires.
- Tighten U-bolts evenly and equally to have the same number of threads exposed on each end.



SIZE ENG.	SIZE METRIC	FOOT POUNDS	NEWTON METERS
1/4-20 1/4-28	M6 x 1	8-10 9-11	11-13 12-15
5/16-18 5/16-24	M8 x 1.25	15-17 17-19	20-23 23-26
3/8-16 3/8-24	M10 x 1.5	25-28 28-31	34-38 38-42
7/16-14 7/16-20	M12 x 1.75	40-45 45-50	54-61 61-68
1/2-13 1/2-20	M14 x 2	62-68 68-75	84-92 92-102
9/16-12 9/16-18	-	90-98 100-110	122-133 134-148
5/8-11 5/8-18	M18 x 2	120-135 124-137	162-183 168-186
3/4-10 3/4-16	M20 x 2.5	200-220 210-230	270-300 285-310
7/8-9 7/8-14	M22 x 2.5	330-350 360-380	425-475 460-515
1-8 1-14	M24 x 3	500-525 540-560	675-710 730-760
1 1/8-7 1 1/8-12	-	600-635 665-700	815-860 920-950
1 1/4-7 1 1/4-12	M30 x 3.5	850-895 940-990	1150-1215 1275-1340
1 3/8-6 1 3/8-12	M36 x 4	1125-1175 1280-1335	1525-1590 1735-1810
1 1/2-6 1 1/2-12	-	1500-1560 1685-1755	2035-2115 2285-2380

IMPORTANT

- Follow these torque recommendations except when specified in text.

Hydraulic Fittings - Torque and Installation

⚠ WARNING

- EYE PROTECTION AND OTHER APPROPRIATE PERSONAL PROTECTIVE EQUIPMENT MUST BE WORN WHILE SERVICING THE IMPLEMENT.
- HIGH-PRESSURE FLUIDS CAN PENETRATE THE SKIN AND CAUSE SERIOUS INJURY OR DEATH. LEAKS OF HIGH-PRESSURE FLUIDS MAY NOT BE VISIBLE. USE CARDBOARD OR WOOD TO DETECT LEAKS IN THE HYDRAULIC SYSTEM. SEEK MEDICAL TREATMENT IMMEDIATELY IF INJURED BY HIGH-PRESSURE FLUIDS.
- HYDRAULIC SYSTEM MUST BE PURGED OF AIR BEFORE OPERATING TO PREVENT SERIOUS INJURY OR DEATH.
- RELIEVE HYDRAULIC SYSTEM OF ALL PRESSURE BEFORE ADJUSTING OR SERVICING. SEE TRACTOR OPERATOR'S MANUAL FOR PROPER PROCEDURES.



Tightening O-Ring Fittings

1. Inspect components for damage or contamination. Do not connect any other type of fitting to an O-ring fitting.
2. For adjustable fittings, ensure the jam nut and washer are fully backed up.
3. Lubricate the O-ring and threads on the fitting with hydraulic oil.
4. Turn the fitting into the port until it is finger tight.
5. For adjustable fittings, set in the desired position.
6. Using a wrench, torque the fitting to the value in the below table. For adjustable fittings the jam nut will be tightened.

NOTE: Never use a power tool to install a fitting.

Dash Size	Thread Size	Straight Stud Torque (Ft-Lbs)	Adjustable Stud Torque (Ft-Lbs)
-5	1/2-20	14-19	10-14
-6	9/16-18	18-24	12-16
-8	3/4-16	27-43	20-30
-10	7/8-14	36-48	30-36
-12	1-1/16-12	65-75	44-54
-14	1-3/16-12	75-99	53-70
-16	1-5/16-12	85-123	59-80
-20	1-5/8"-12	115-161	75-100
-24	1-7/8"-12	125-170	105-125

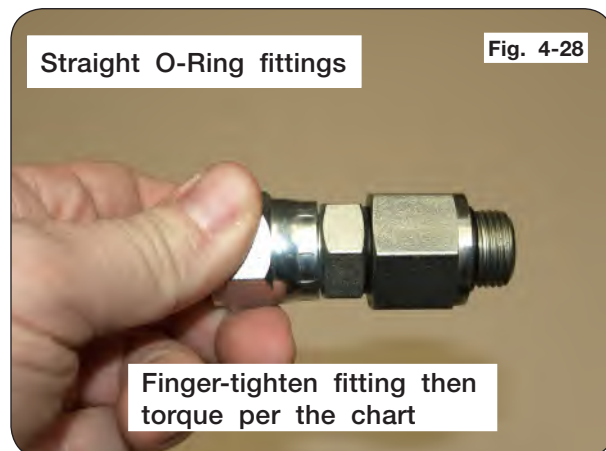

Hydraulic Fittings - Torque and Installation (continued)

Tightening JIC Fittings

1. Inspect all components for damage or contamination. Do not connect any other type of fitting to a JIC fitting.
2. Lubricate the threads with hydraulic oil.
3. Turn the fitting into the port until it bottoms out.
4. Use one wrench on the fixed hex on the hose to prevent twisting and a second on the swivel. Tighten the fitting another 60 degrees (or one flat)

NOTE: Never use a power tool to install a fitting

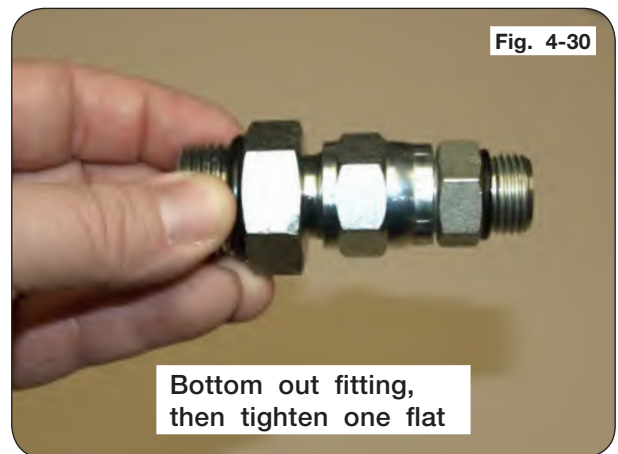

Notes

Section V

Parts

Decals	5-2
Frame & Tongue	5-4
Steerable Hitch Option.....	5-6
Standard Cast Hitch.....	5-9
Ladder	5-10
Platform, Railings - Models 1200 / 1600	5-12
Platform, Railings - Model 2400.....	5-14
Gauge Panel.....	5-16
Toolbox, Side Panels & Command Center Mounting	5-18
Axle	5-20
Suspended Axle.....	5-22
Hub & Spindle	5-24
Wheels & Tires - Models 1200 / 1600	5-26
Wheels & Tires - Model 2400.....	5-30
Equalizer Track Components - Model 1600.....	5-32
Equalizer Track Components - Model 2400.....	5-33
Mast.....	5-34
Lift Assembly, H-Frame.....	5-36
Command Center 4 Components.....	5-38
Command Center 4 Components (Optional Wireless Boom Control)	4-40
GEN 1 ISO Rate Control (RCM) Components.....	5-42
Hose Bracket.....	5-46
Strainer.....	5-47
Main Tank	5-48
Main Tank Plumbing	5-50
Front Plumbing Components - Models 1200 / 1600 / 2400	5-52
Rear Plumbing Components - Models 1200 / 1600 / 2400	5-54
Plumbing Overhead Layout - Models 1200 / 1600 / 2400	5-56
Hydraulic Valve Conversions	5-57
Hydraulic Valve.....	5-58
Inductor Plumbing (Optional).....	5-60
Inductor Mounting (Optional).....	5-64
Rinse Tank	5-66
Sight Gauge	5-68
Spray System & Command Center	5-70
Solution Tank Quick Fill.....	5-72
Spray Pump - ACE (304 PWM / 206) & Optional HYPRO.....	5-74
Spray Pump - (ACE HYD 750 PWM Plumbing).....	5-76
PWM Pump - (ACE 750 PWM & ACE 755).....	5-78
Spray Pump - (ACE FMCS 205F HYD 304 PWM).....	5-80
Spray Pump - (ACE FMCS 150 HYD 206).....	5-82
Spray Pump - (HYPRO 9306C-HM1C).....	5-84
Foam Marker (Optional).....	5-86
Foam Marker Assembly (Optional).....	5-88
Double Drop Foam Marker Components (Optional).....	5-90
Electric Controls (Optional).....	5-92
Raven ISO Tank Fill Meter	5-94

Sprayer TA1200 / TA1600 / TA2400 — Parts

Decals

Please visit www.unverferth.com/parts/ for the most current parts listing.

The diagram illustrates the placement of 46 numbered decals on a sprayer. It includes two vertical height scales on the left side, ranging from 50 to 2400 units. The model names TA1200, TA1600, and TA2400 are prominently displayed in the center. Various safety and operational warning labels are shown, including:

- 30:** Recirculation Valve label with ON/OFF positions.
- 1:** Warning label: NO RIDING. FALLING CAN CAUSE SERIOUS INJURY OR DEATH.
- 2:** Warning label: TO DISABLE BOOM RECIRCULATION MOVE VALVE HANDLE TO OFF POSITION.
- 20:** Warning label: STAND CLEAR OF HIGH-PRESSURE HOSE END OF SPRAYING BOOM. FAILURE TO DO SO MAY CAUSE PERSONAL INJURY OR DEATH.
- 34:** UM Wheel Products unverferth.com logo with text: Always consult your operator's manual for correct tire pressure and wheel hardware torque specifications.
- 21:** Warning label: ALWAYS RELEASE TRIGGER AND LOCK SYSTEM BEFORE LEAVING THE BOOM. FAILURE TO DO SO MAY CAUSE PERSONAL INJURY OR DEATH.
- 22:** Warning label: HIGH-PRESSURE FLUID CAN CAUSE PERSONAL INJURY OR DEATH. NEVER OPEN HOSE OR FITTING UNTIL PRESSURE HAS BEEN RELEASED BY THE OPERATOR.
- 23:** Warning label: HIGH-PRESSURE FLUID CAN CAUSE PERSONAL INJURY OR DEATH. ACCUMULATOR MAINTENANCE PROCEDURES IN HYDRA-FLY SYSTEM. See operator's manual for procedure to follow.
- 17:** THIS PRODUCT IS MANUFACTURED IN THE U.S.A. label.
- 39, 35:** Speed limit signs: 20 mile/h.
- 24:** Arc flash warning label: A B C D E.
- 44:** DANGER label: ELECTRIC SHOCK CAN CAUSE SERIOUS INJURY OR DEATH. KEEP AWAY FROM UTILITY LINES.
- 16:** Label: FILTER INLET PRESSURE.
- 15:** Label: AGITATOR CONTROL.
- 14:** Label: PUMP SELECTOR.
- 13:** Label: TANK AGITATION.
- 40, 36:** Speed limit signs: 30 km/h.
- 41, 37:** Speed limit signs: 15 mile/h.
- 38, 25:** Speed limit signs: 25 km/h.
- 25:** Warning label: Improper adjustment can cause side to separate from sprayer, resulting in an accident and personal injury. DO NOT EXCEED ENGINEER'S DESIGN. Check fastener torques after first hour of use and weekly thereafter.
- 26:** Warning label: IMPROPER ADJUSTMENT CAN CAUSE A BOLT TO SEPARATE FROM THE SPRAYER RESULTING IN AN ACCIDENT AND PERSONAL INJURY. DO NOT EXCEED ENGINEER'S DESIGN. CHECK FASTENER TORQUES AFTER FIRST HOUR OF USE AND WEEKLY THEREAFTER.
- 12:** Label: FILTER HOSE CONTROL.
- 27:** SPRAYER OPERATING INSTRUCTIONS label.
- 31:** INDUCTOR OPERATING INSTRUCTIONS label.
- 11:** Top All label.
- 10:** Label: FILTER INLET PRESSURE.
- 9:** Label: TIP PRESSURE.
- 8:** IMPORTANT label: To prevent inadvertent boom movement out of wing rests, hold boom lift switches down for an additional 15 seconds after booms are completely sealed in rests to drain accumulators.
- 28:** IMPORTANT label: To prevent inadvertent boom movement out of wing rests, hold boom lift switches down for an additional 15 seconds after booms are completely sealed in rests to drain accumulators.
- 43:** IMPORTANT label: To prevent inadvertent boom movement out of wing rests, hold boom lift switches down for an additional 15 seconds after booms are completely sealed in rests to drain accumulators.
- 45:** Label: TANK AGITATION.
- 32:** IMPORTANT label: TO ISOLATE PUMP WHEN SERVICING: 1. Manually close auxiliary valve located on the suction line under the rest tank. 2. Hold filter gauge valve until valve is off (approx. 10 sec.). 3. Hold agitator switch until valve is off (approx. 10 sec.).
- 33:** IMPORTANT label: TO ISOLATE PUMP WHEN SERVICING: 1. Turn back flow valve off by rotating a counter bolt. 2. Turn filter gauge down to off position. 3. Hold agitator switch until valve is off (approx. 10 sec.).
- 3:** DANGER label: HAZARDOUS VOLTAGE CAN SHOCK, BURN, OR KILL. KEEP AWAY FROM OVERHEAD ELECTRICAL WIRES AND DEVICES. TRAVEL A ROUTE AWAY FROM OR WELL BELOW OVERHEAD ELECTRICAL LINES. FAILURE TO HEED MAY RESULT IN ELECTRICAL SHOCK, BURN, OR DEATH.
- 4:** Warning label: NO RIDING. FALLING CAN CAUSE SERIOUS INJURY OR DEATH.
- 5:** Filter gauge label.
- 6:** Filter gauge label.
- 7:** IMPORTANT label: To prevent inadvertent boom movement out of wing rests, hold boom lift switches down for an additional 15 seconds after booms are completely sealed in rests to drain accumulators.

Sprayer TA1200 / TA1600 / TA2400 — Parts

Decals

Please visit www.unverferth.com/parts/ for the most current parts listing.

ITEM	PART NO.			DESCRIPTION	QTY.	NOTES
	1200	1600	2400			
1	-	9004834	-	Decal, Volume Indicator (Gray)	1	
2	9004817	-	-	Decal, Volume Indicator (Gray)	1	
3	TA510544	>	>	Decal, DANGER (Overhead Electrical)	1	
4	9003476	>	>	Decal, WARNING (No Riders)	1	
5	9003807	>	>	Decal, Indicator (Right-Hand)	1	
6	9003808	>	>	Decal, Indicator (Left-Hand)	1	
7	TA510212	>	>	Decal, IMPORTANT (Hydraulic Pressure)	1	
8	9004353	>	>	Decal, IMPORTANT (Boom Sway)	1	
9	9003841	>	>	Decal, Tip Pressure	1	
10	9003687	>	>	Decal, Filter Inlet Pressure	1	
11	TA510008	>	TA510041	Decal, Top Air Logo (1x3)	1	
12	9004557	>	>	Decal, Filter Purge Control	1	
13	9005369	>	9004558	Decal, Pump Inlet	1	
14	9004559	>	>	Decal, Pump Outlet	1	
15	9004561	>	>	Decal, Agitation Control	1	
16	93459	>	>	Decal, 8-Hours Grease	3	
17	TA510031	>	>	Decal, USA	2	
18	9005863	-	-	Decal, 1200 (Gray) 3 x 11	3	Used on Steerable Hitch Tongue & "A" Frame Tongue
	9004863	-	-	Decal, 1200 (Gray) 5 x 18 3/8	1	Used on Frame
19	-	9004861	-	Decal, 1600 (Gray) 5 x 18 9/16	1	Used on Frame
	-	9005839	-	Decal, 1600 (Gray) 3 x 11 1/8	3	Used on "A" Frame Tongue
20	TA510079	>	>	Decal, WARNING (Boom Unfolding)	2	
21	94094	>	>	Decal, WARNING (Tongue)	1	
22	95445	>	>	Decal, WARNING (High Pressure Fluid)	1	
23	900024	>	>	Decal, WARNING (High Pressure Oil)	1	
24	9004722	>	>	Decal, Indicator	1	
25	9004286	-	-	Decal, WARNING (Axle Adjustment)	1	Non-Suspended Axle
26	9003846	>	>	Decal, WARNING (Axle Adjustment)	1	Suspended Axle
27	9005370	>	>	Decal, Sprayer Instructions	1	
28	9005958	>	9005959	Tag, IMPORTANT - Bypass Plumbing	1	
29	-	-	9004958	Decal, 2400 (Gray) LH Frame	1	
	-	-	9005855	Decal, 2400 (Gray) Tongue	2	Used on "A" Frame Tongue
30	-	-	9004852	Decal, Volume Indicator (Gray)	1	
31	-	-	9004324	Decal, Inductor Operation	1	
32	-	-	9006474	Decal, IMPORTANT (Pump Isolation)	1	Used on Units with Electric Command Center Option
33	-	-	9006475	Decal, IMPORTANT (Pump Isolation)	1	
34	94754	>	>	Decal, Wheel Systems	1	
35	9008715	>	>	Decal, Front SIS 20 MPH	1	Wheels
36	9008721	>	>	Decal, Front SIS 30 KPH	1	
37	9008717	>	>	Decal, Front SIS 15 MPH	1	Tracks
38	9008723	>	>	Decal, Front SIS 25 KPH	1	
39	9008714	>	>	Decal, Rear SIS 20 MPH	1	Wheels
40	9008720	>	>	Decal, Rear SIS 30 KPH	1	
41	9008716	>	>	Decal, Rear SIS 15 MPH	1	Tracks
42	9008722	>	>	Decal, Rear SIS 25 KPH	1	
43	9004755	>	>	Decal, IMPORTANT (Drain Accumulator)	1	
44	901258	>	>	Decal, DANGER (Electric Shock)	1	
45	9009844	>	>	Decal, Tank Agitation	1	
46	9010299	>	>	Decal, Recirculation Valve	1	Refer to "Boom" Manual and "Decals" Section For More Information

Frame & Tongue

Please visit www.unverferth.com/parts/ for the most current parts listing.

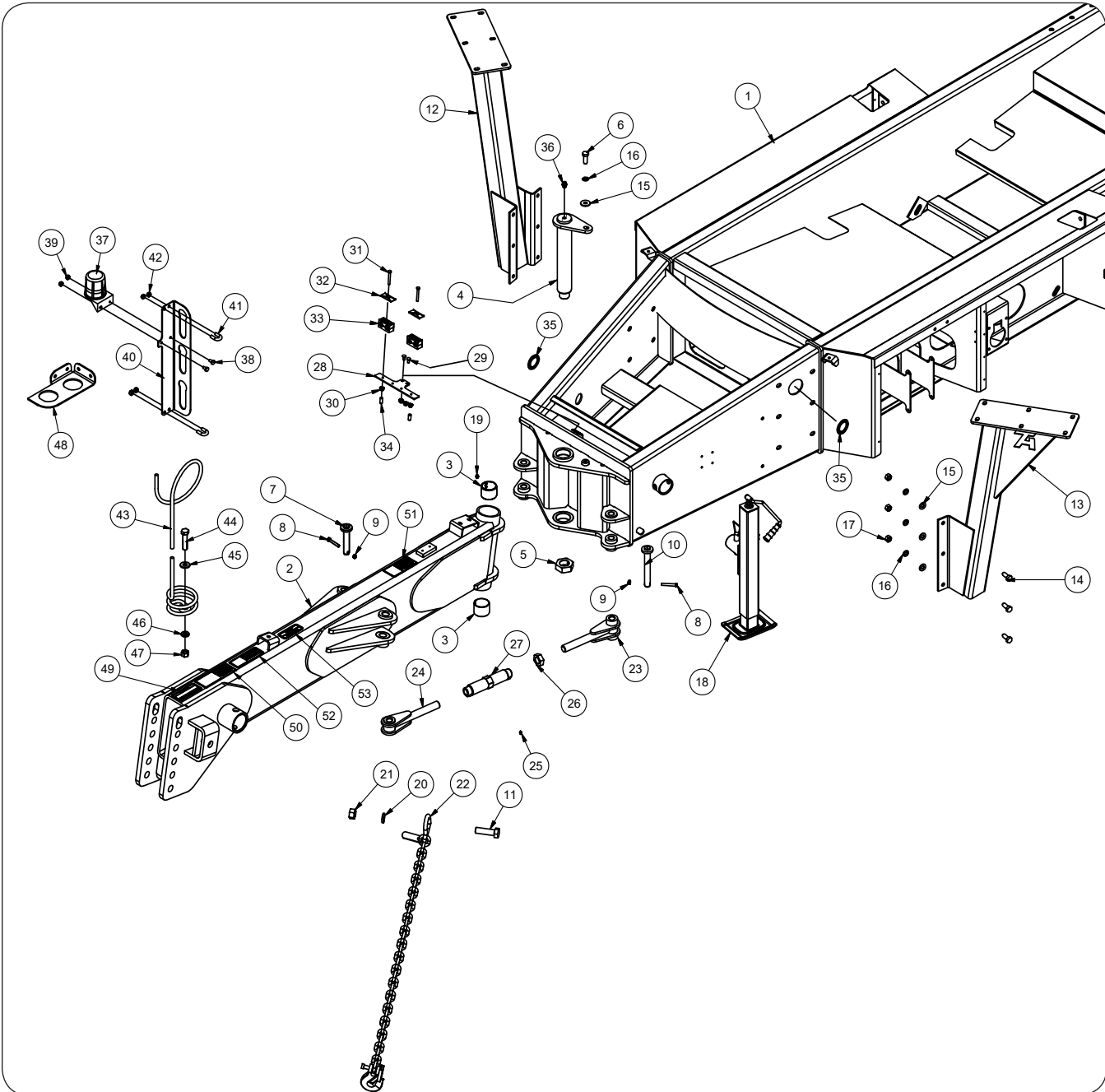

ITEM	PART NO.			DESCRIPTION	QTY.	NOTES
	1200	1600	2400			
1	408100G	407757G	407782G	Frame Weldment =Green=	1	
	408100R	407757R	407782R	Frame Weldment =Red=	1	
2	43299G	>	>	Tongue Weldment =Green=	1	Includes Items 3, 19, 49 to 52
	43299R	>	>	Tongue Weldment =Red=	1	
3	9003230	>	>	Split Bushing	2	
4	408090	>	>	Tongue Pin	1	
5	9005290	>	>	Hex Jam Nut w/Set Screw 1 3/4-5UNC	1	
6	9390-123	>	>	Capscrew 5/8-11UNC x 1 3/4	1	

Sprayer TA1200 / TA1600 / TA2400 — Parts

Frame & Tongue

Please visit www.unverferth.com/parts/ for the most current parts listing.

ITEM	PART NO.			DESCRIPTION	QTY.	NOTES
	1200	1600	2400			
7	407588	>	>	Cylinder Pin 1" Dia. x 5 7/8	2	
8	9390-061	>	>	Capscrew 3/8-16UNC x 2 1/2	4	
9	9928	>	>	Locknut 3/8-16UNC	4	
10	407589	>	>	Cylinder Pin 1" Dia. x 8 1/8	2	
11	9390-188	>	>	Capscrew, 1-8UNC x 3 1/4	1	Grade 5
12	402098G	401126G	401126G	RH Wing Rest Weldment =Green=	1	
	402098R	401126R	401126R	RH Wing Rest Weldment =Red=	1	
13	402099G	401127G	401127G	LH Wing Rest Weldment =Green=	1	
	402099R	401127R	401127R	LH Wing Rest Weldment =Red=	1	
14	9390-122	>	>	Capscrew, 5/8-11UNC x 1 1/2	6	Grade 5
15	9405-100	>	>	Flat Washer, 5/8	7	
16	9404-029	>	>	Lock Washer, 5/8	7	
17	9394-014	>	>	Hex Nut, 5/8-11UNC	6	Grade 5
18	9003295	>	>	Jack, 7000#	1	
19	9000875	>	>	90° Grease Zerk	1	
20	9404-041	>	>	Lock Washer, 1"	1	
21	9394-020	>	>	Hex Nut, 1-8UNC	1	Grade 5
22	9003265	>	95055	Transport Chain w/Hook, Eye, Decal	1	
23	407742	>	>	RH Tongue Adjustment End Weldment	1	
24	407745	>	>	LH Tongue Adjustment End Weldment	1	
25	91160	>	>	Grease Zerk	2	
26	9395-024	>	>	Hex Jam Nut 1 1/4UNC	1	
27	62324	>	>	Turnbuckle	1	
28	407770B	>	>	Hose Bracket =Black=	1	
29	9388-024	>	>	Carriage Bolt 5/16-18UNC x 3/4	2	
30	91257	>	>	Serrated Flange Nut 5/16-18UNC	4	
31	9390-035	>	>	Capscrew 5/16-18UNC x 2 1/4	2	
32	9004857	>	>	Top Plate	2	
33	9004856	>	>	Hose Clamp	2	
34	9005985	>	>	Vinyl Cap	2	
35	9004485	>	>	3" Rubber Grommet	2	
36	9006310	>	>	Threaded Plastic Plug	1	
37	9001968	>	>	Connector Holder	1	
38	9390-001	>	>	Capscrew, 1/4-20UNC x 1/2	2	Grade 5
39	9936	>	>	Lock Nut, 1/4-20UNC	2	Grade 5
40	415546	>	>	Hose Holder	1	
41	9006429	>	>	U-Bolt, 5/16-18UNC x 15/16 x 3/4 C/C	2	Grade 5
42	9807	>	>	Lock Nut, 5/16-18UNC	4	Grade 5
43	9006424	>	>	Coil Spring Hose Holder	1	
44	9390-101	>	>	Capscrew, 1/2-13UNC x 1 1/2	1	Grade 5
45	9405-088	>	>	Flat Washer, 1/2 USS	1	
46	9404-025	>	>	Lock Washer, 1/2	1	
47	9394-010	>	>	Hex Nut, 1/2-13UNC	1	Grade 5
48	409880B	>	>	IBBC Plate Bracket =Black=	1	
49	901258	>	>	Decal, DANGER (Electric Shock)	1	
50	94094	>	>	Decal, WARNING (Tongue)	1	
51	95445	>	>	Decal, WARNING (High Pressure Oil)	1	
52	97575	>	>	Decal, CAUTION (Transport Chain)	1	
53	9010034	>	>	Decal, Hose Legend	1	

Steerable Hitch Option

Please visit www.unverferth.com/parts/ for the most current parts listing.

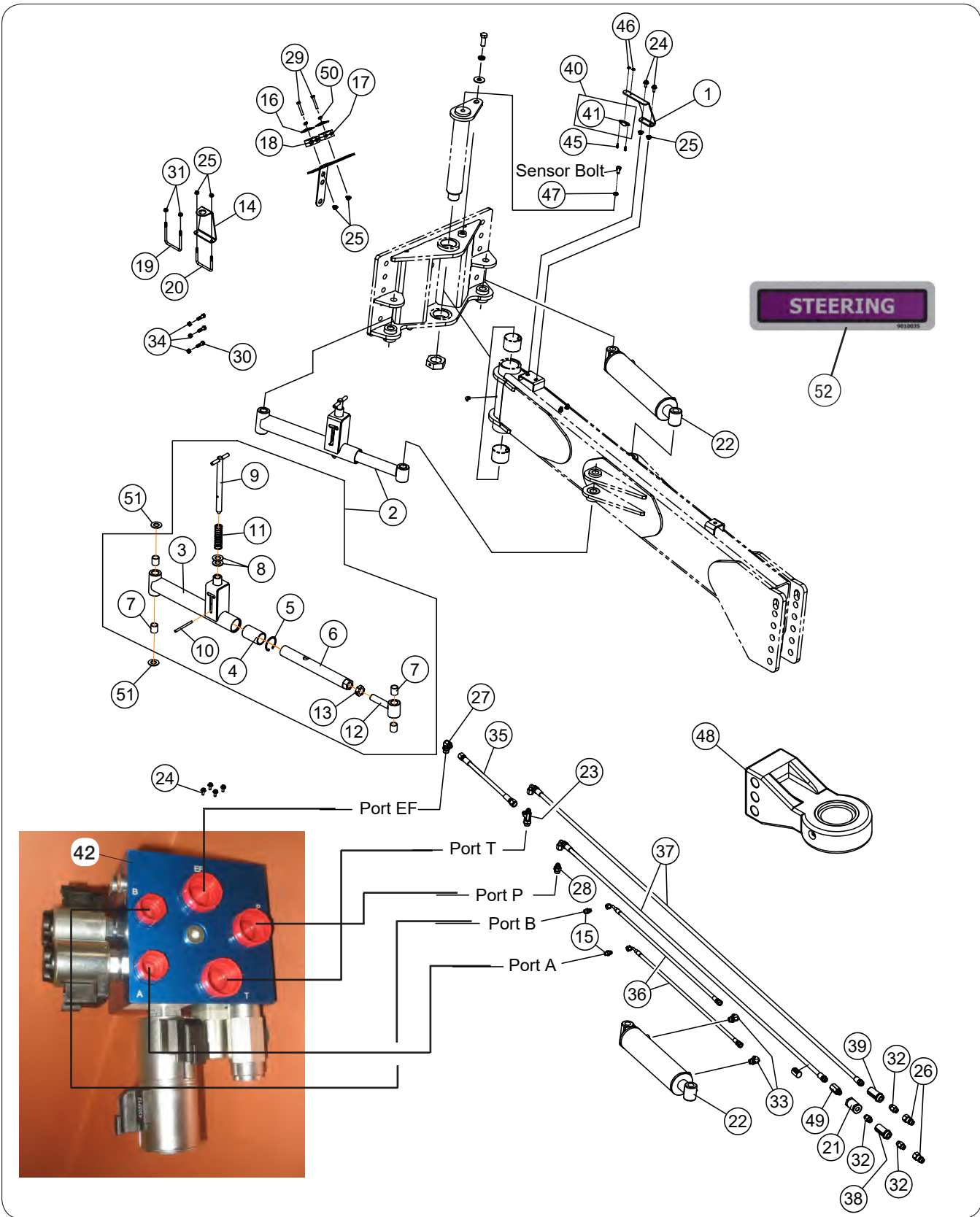

Steerable Hitch Option

Please visit www.unverferth.com/parts/ for the most current parts listing.

ITEM	PART NO.	DESCRIPTION	QTY.	NOTES
1	408092B	Rotary Sensor Bracket Plate (Black)	1	
2	407795B	Lock Assembly (Black)	1	Includes Items 3 - 13
3	407707B	Lock Tube Weldment w/ Pin Chamber =Black=	1	
4	407723	Bushing Guide 2.135" OD	1	
5	9006206	Internal Retaining Ring	1	
6	408613B	Lock Tube Weldment =Black=	1	
7	9003440	Self-Lubricating Bushing, 1.13" OD x 1 1/4" Long	4	
8	9405-110	Flat Washer 7/8"	2	
9	408364	Lock Pin Weldment, 7/8" Dia. x 11	1	
10	9392-167	Roll Pin 5/16" Dia. x 4	1	
11	9005788	Compression Spring	1	
12	408615	Adjustment Rod Weldment	1	
13	9395-020	Hex Jam Nut, 1-8UNC Gr.5	1	
14	407906B	Prox. Switch Bracket Plate =Black=	1	
15	9006150	Adapter 9/16-18 JIC Flare-O Male x 9/16-18 O-Ring Male	2	
16	9003814	Clamp Top Plate	2	
17	9003816	Poly Clamp Pair For 1/4" Hose	2	
18	9004367	Poly Clamp Pair For 3/8" Hose	2	
19	9004454	U-Bolt 1/4-20UNC x 3 3/4 (Used on 120'/132' Booms)	1	
20	9005281	U-Bolt 5/16-18UNC x 2 3/4 (Used on 80'/90'/100' Booms)	1	
21	9005403	Micron Hyd Filter	1	
22	9005673	Welded Cylinder 3 1/2 x 12	1	
	9006653	Seal Kit for Cylinder 3 1/2 x 12	1	
23	9006174	Tee 3/4-16 JIC Flare-O Male x 7/8-14 O-Ring Male x 3/4-16 JIC Flare-O Male	1	
24	91256	Screw/Large Flange, 5/16-18UNC x 3/4	6	
25	91257	Flange Nut 5/16-18UNC	6	
26	91383	Male Tip Coupling 3/4-16	2	
27	9006175	90° Elbow 3/4-16 JIC Flare-O Male x 7/8-14 O-Ring Male	1	
28	9006176	Adapter 3/4-16 JIC Flare-O Male x 7/8-14 O-Ring Male	1	
29	9390-034	Capscrew, 5/16-18UNC x 2 Gr.5	2	
30	9390-055	Capscrew, 3/8-16UNC x 1 Gr.5	3	
31	97189	Hex Nut/Large Flange, 1/4-20UNC	2	
32	98508	Adapter, 3/4-16 O-Ring Male x 3/4-16 O-Ring Male	3	
33	9006173	90° Elbow 9/16-18 JIC Male x 3/4-16 O-Ring Male	2	
34	9398-012	Elastic Locknut 3/8-16UNC	3	

(Continued on next page)

Steerable Hitch Option (continued)

Please visit www.unverferth.com/parts/ for the most current parts listing.

ITEM	PART NO.	DESCRIPTION	QTY.	NOTES
35	9001228	Hose 3/8" Dia. x 15" 3/4"-16 JIC F x 3/4"-16 JIC F	1	
36	9005864	Hose, 1/4" x 66" 90° Elbow 9/16"-18 JIC Female x 9/16"-18 JIC Female	2	
37	9005869	Hose, 3/8" Dia. x 156" 90° Elbow 3/4"-16 JIC Female x 3/4"-16 Male O-Ring	2	
38	9009763	Hose Grips - Purple (+ Extend Port)	1	Steerable Hitch Pressure
39	9009764	Hose Grips - Purple (- Retract Port)	1	Steerable Hitch Return
40	9006721	Steerable Hitch Kit	1	Includes Items 41 - 44
41	9006222	Non-Contact Rotary Sensor	1	Includes Sensor Bolt
42	9005925	Complete Valve Block Assembly	1	
43	9005932	Proximity Sensor (Not Shown)	1	
44	9005924	Raven Steerable Hitch Manual (Not Shown)	1	
45	9006042	Washer Head Capscrew, #8-32 x 1/2"	2	
46	9006041	Serrated Flange Nut, #8-32	2	
47	9005874	Hex Jam Nut, M10x1.0	1	
48	JAP3228	Ball and Socket Cast Hitch, CAT IV	1	See "Standard Cast Hitch" Section
49	94909	Check Valve	1	
50	9404-019	Lock Washer, 5/16"	2	
51	9405-116	Flat Washer 1" SAE	2	
52	9010035	Decal, Hose Legend Steering	1	

Standard Cast Hitch

Please visit www.unverferth.com/parts/ for the most current parts listing.

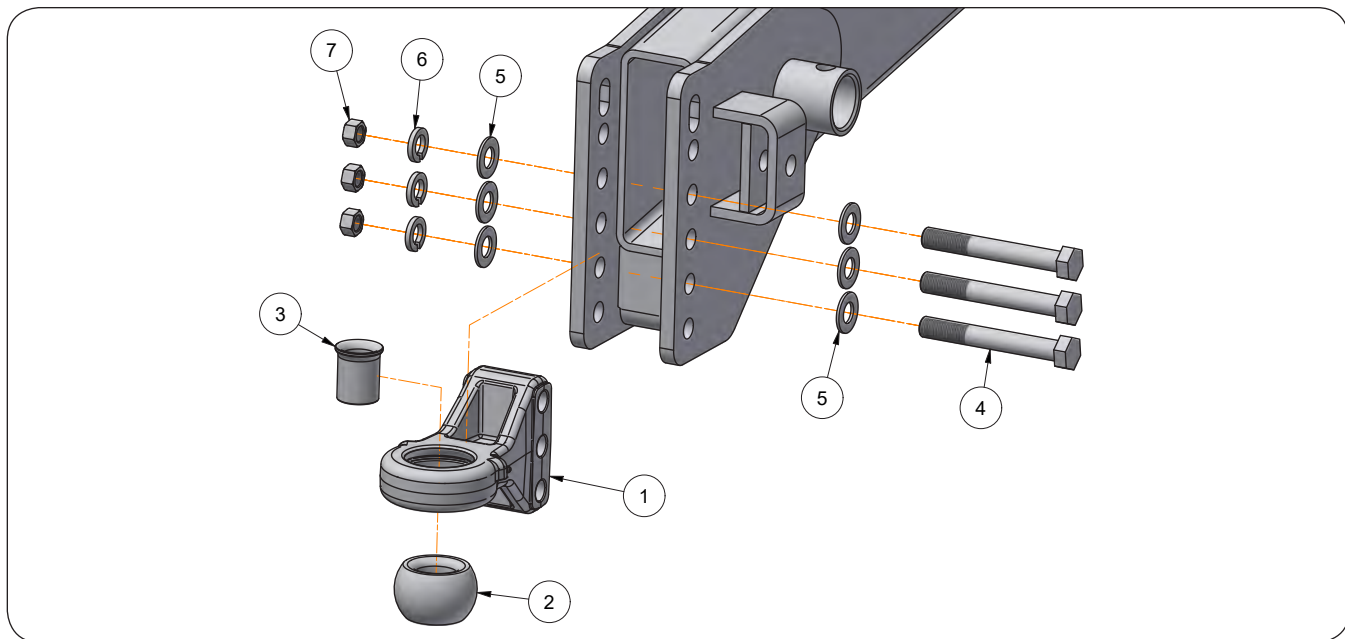

ITEM	PART NO.	DESCRIPTION	QTY.	NOTES
1	JAP3228	Swivel Hitch CAT IV	1	Includes Item 2
2	9503978	Replacement Bushing, CAT IV Ball	1	
3	9009655	Hitch Bushing, 1 1/2" Dia.	1	
4	9390-198	Capscrew 1"-8UNC x 7" Grade 5	3	
5	9405-116	Flat Washer 1"	6	
6	9404-041	Lock Washer 1"	3	
7	9394-020	Hex Nut 1"-8UNC	3	

Ladder

Please visit www.unverferth.com/parts/ for the most current parts listing.

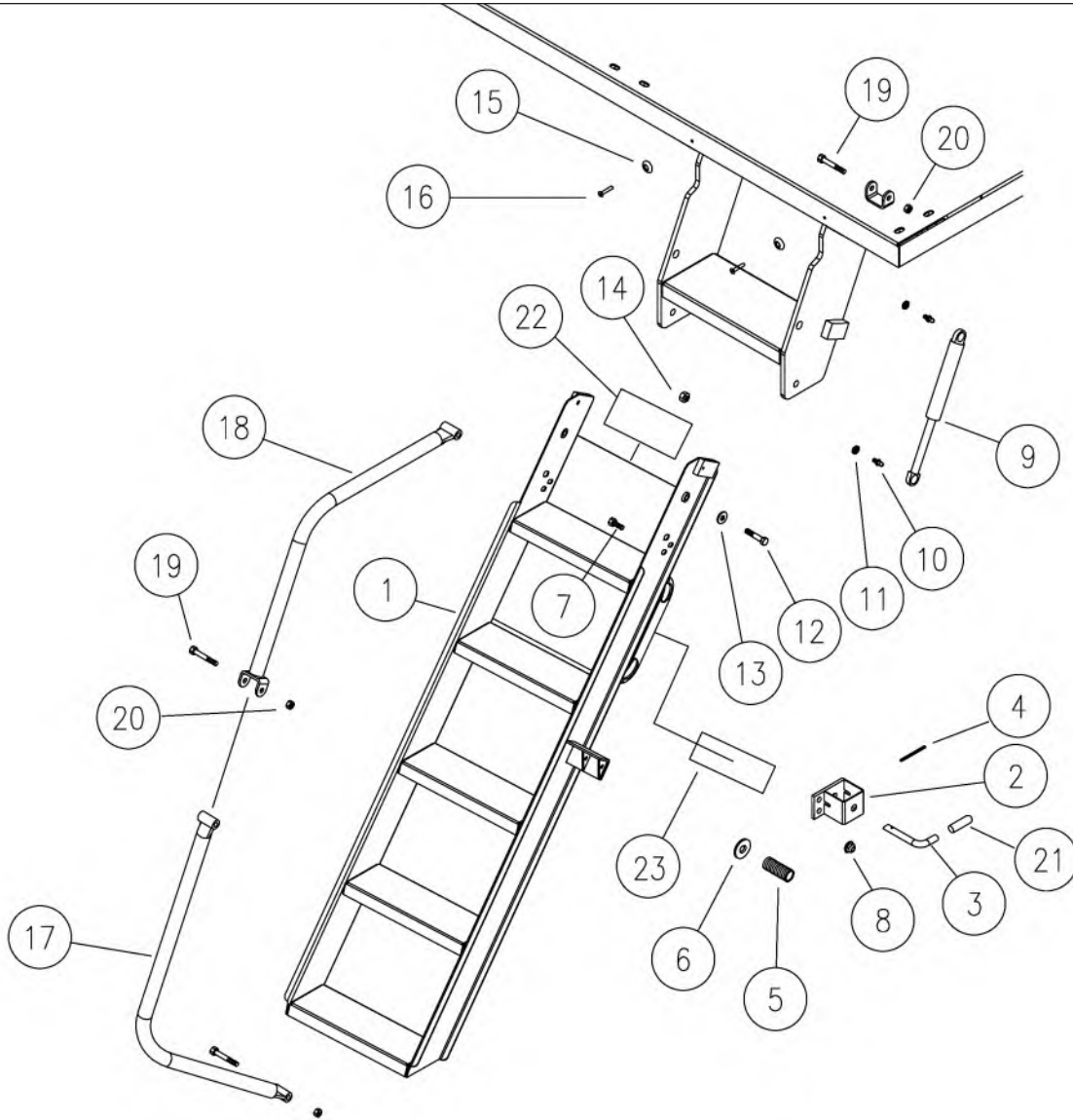

Sprayer TA1200 / TA1600 / TA2400 — Parts

Ladder

Please visit www.unverferth.com/parts/ for the most current parts listing.

ITEM	PART NO.			DESCRIPTION	QTY.	NOTES
	1200	1600	2400			
1	43297G	43298G	43295G	Ladder Weldment =Green=	1	Includes Items 22 and 23
	43297R	43298R	43295R	Ladder Weldment =Red=		
2	401879B	>	>	Latch Pin Weldment	1	
3	401880	>	>	Pin, 1/2" Dia. x 5 3/8	1	
4	9392-107	>	>	Poll Pin, 3/16" Dia. x 2 1/2	1	
5	TA510035	>	>	Spring, 2 1/2" Long	1	
6	9405-088	>	>	Flat Washer, 1/2	1	
7	9390-054	>	>	Capscrew, 3/8-16UNC x 7/8	2	Grade 5
8	91263	>	>	Nut/Large Flg, 3/8-16UNC	2	
9	9003685	>	>	Gas Spring, 6.30" Stroke	2	
10	9003832	>	>	Ball Stud	4	
11	9404-019	>	>	Lock Washer, 5/16	4	
12	9390-101	>	>	Capscrew, 1/2-13NC x 1 1/2	2	Grade 5
13	9405-088	>	>	Flat Washer, 1/2	2	
14	94981	>	9395-010	Locknut, 1/2-13UNC	2	
15	9003850	>	>	Bumper	2	
16	TA0-908386-0	>	>	Pop Rivet, 3/16	2	
17	401829G	>	>	Lower Handrail Weldment =Green=	1	
	401829R	>	>	Lower Handrail Weldment =Red=		
18	401847G	>	>	Upper Handrail Weldment =Green=	1	
	401847R	>	>	Upper Handrail Weldment =Red=		
19	9390-060	>	9390-061	Capscrew, 3/8-16UNC x 2 1/4	2	Grade 5
20	9003396	>	>	Locknut, 3/8-16UNC	3	Grade 5
21	9003870	>	>	Grip	1	
22	901258	>	>	Decal, DANGER (Electric Shock)	1	
23	9003476	>	>	Decal, WARNING (No Riders)	1	

Platform, Railings - Models 1200 / 1600

Please visit www.unverferth.com/parts/ for the most current parts listing.

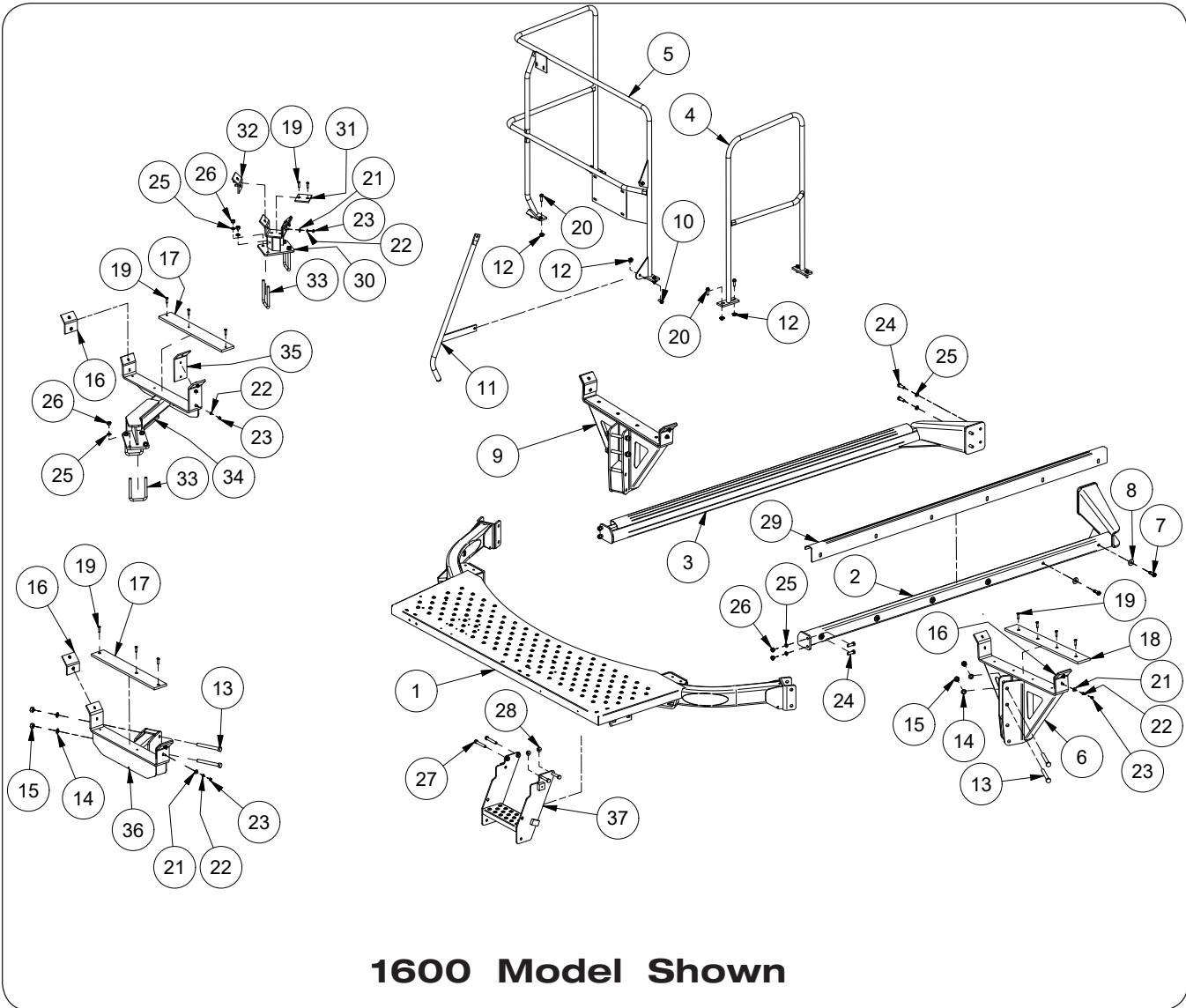

Sprayer TA1200 / TA1600 / TA2400 — Parts

Platform, Railings - Models 1200 / 1600

Please visit www.unverferth.com/parts/ for the most current parts listing.

ITEM	PART NO.		DESCRIPTION	QTY.	NOTES
	1200	1600		(60'/80'-90'/ 110'-132')	
1	402093G	402875G	Platform Weldment =Green=	1	
	402093R	402875R	Platform Weldment =Red=		
2	402817G	401838G	LH Perimeter Weldment =Green=	1	
	402817R	401838R	LH Perimeter Weldment =Red=		
3	402818G	401839G	RH Perimeter Weldment =Green=	1	
	402818R	401839R	RH Perimeter Weldment =Red=		
4	403773G	403773G	LH Platform Railing Weldment =Green=	1	
	403773R	403773R	LH Platform Railing Weldment =Red=		
5	409253R	409253R	RH Platform Railing Weldment =Green=	1	
	409253G	409253G	RH Platform Railing Weldment =Red=		
6	-	403753B	Rest Weldment, LH =Black=	1	Used With 110', 120', 132' Wings
7	-	9009818	Box Bolt 5/16"-18UNC Grade 8	12	
8	-	9405-088	Flat Washer 1/2" USS	12	
9	-	403754B	Rest Weldment, RH =Black=	1	Used With 110', 120', 132' Wings
10	91262	91262	Screw/Lrg Flg 3/8-16UNC x 1 Grade 5	2	
11	407738G	407738G	Handrail Weldment =Green=	1	
	407738R	407738R	Handrail Weldment =Red=		
12	91263	91263	Nut/Lrg Flg 3/8-16UNC Grade 5	12	
13	-	9390-135	Capscrew 5/8-11UNC x 5 1/2 Grade 5	4	
14	-	9404-029	Lock Washer 5/8	4	
15	-	9394-014	Hex Nut 5/8-11UNC Grade 5	4	
16	402609	400875	Pad Rest	2*/4	*For 1200 60' Sprayer
17	-	408582	Pad Rest 23"	2	
18	-	403784	Pad Rest 26 3/4"	2	
19	903171-662	903171-662	Phillips Screw 5/16-18UNC x 1 1/4	12/14/16	
20	9003259	9003259	Capscrew Flg 3/8-16UNC x 1 1/4 Grade 5	10	
21	9405-070	9405-070	Flat Washer, 5/16" USS	12/14/16	
22	9404-019	9404-019	Lock Washer, 5/16	12/14/16	
23	9394-004	9394-004	Nut, 5/16-18UNC Grade 5	12/14/16	
24	9390-101	9390-101	Capscrew 1/2-13UNC x 1 1/2 Grade 5	12	
25	9404-025	9404-025	Lock Washer, 1/2	20	
26	9394-010	9394-010	Nut, 1/2-13UNC Grade 5	12	
27	9390-108	9390-108	Capscrew, 1/2-13UNC x 3 1/4 Grade 5	4	
28	9003397	9003397	Flange Nut, 1/2-13UNC Gr.5	4	
29	-	416458	Tank Support Plate	2	
30	402604B	-	Rest Weldment, RH =Black=	1	Used With 60' Wings
	402605B	-	Rest Weldment, LH =Black=		Used With 60' Wings
31	402601	-	Pad Rest 3 1/8" Long	2	
32	402609	-	Pad Rest 3 1/2" Wide	2	
33	804176	-	U-Bolt, 1/2"	4	
34	408565B	-	Rest Weldment, RH =Black=	1	Used With 80-90' Wings
	408566B	-	Rest Weldment, LH =Black=	1	Used With 80-90' Wings
35	401561	-	Pad Rest With Three Holes	2	
36	-	408583B	Rest Weldment, RH =Black=	1	Used With 80-90' Wings
	-	408584B	Rest Weldment, LH =Black=	1	Used With 80-90' Wings
37	411043G	411037G	Step Weldment =Green=	1	
	411043R	411037R	Step Weldment =Red=	1	

Platform, Railings - Models 2400

Please visit www.unverferth.com/parts/ for the most current parts listing.

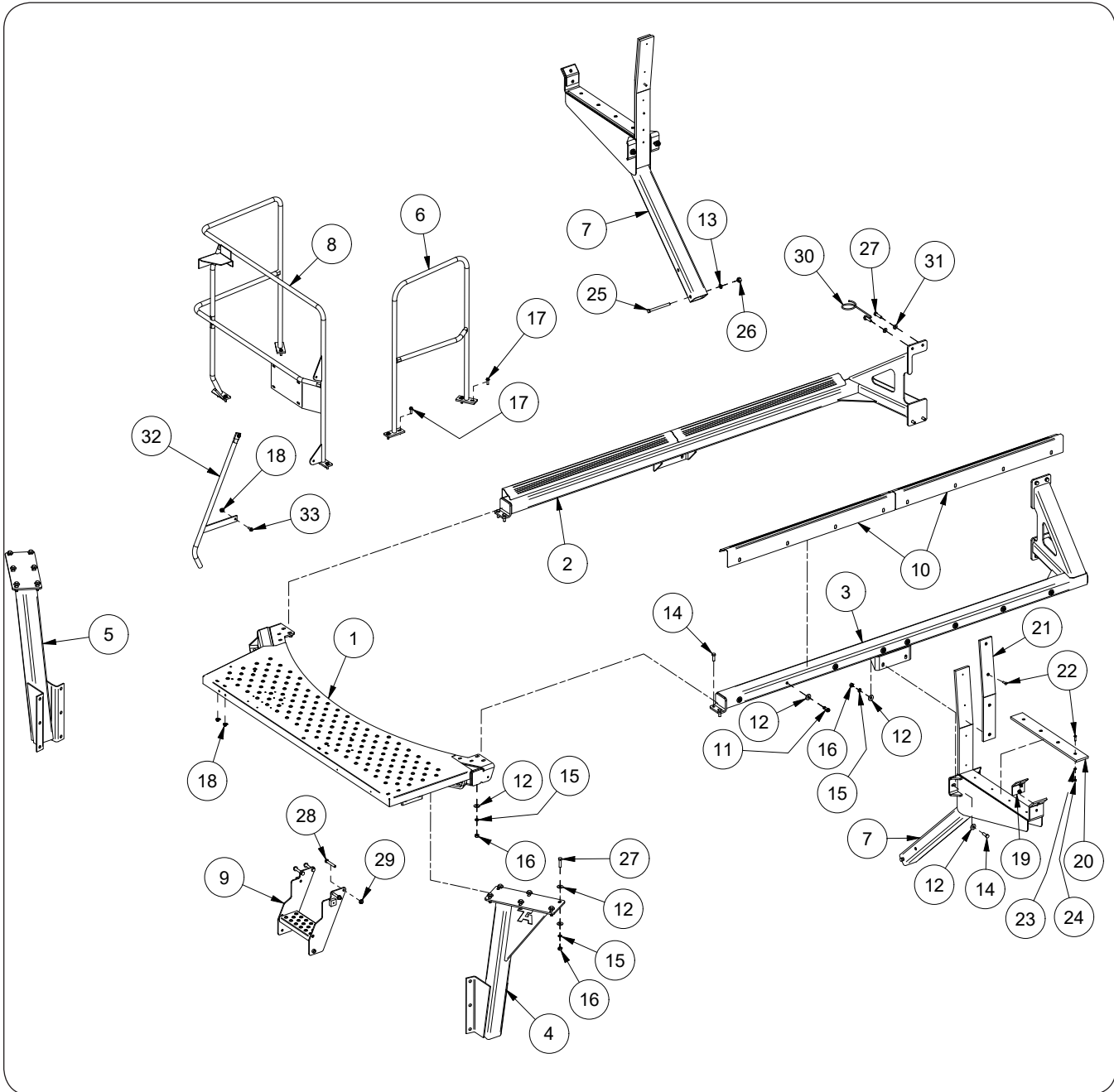

ITEM	PART NO.	DESCRIPTION	QTY.	NOTES
1	403028G	Platform Weldment =Green=	1	
	403028R	Platform Weldment =Red=		
2	403866G	RH Perimeter Weldment =Green=	1	
	403866R	RH Perimeter Weldment =Red=		
3	403867G	LH Perimeter Weldment =Green=	1	
	403867R	LH Perimeter Weldment =Red=		

Platform, Railings - Models 2400

Please visit www.unverferth.com/parts/ for the most current parts listing.

ITEM	PART NO.	DESCRIPTION	QTY.	NOTES
4	401127G	LH Rest Weldment =Green=	1	
	401127R	LH Rest Weldment =Red=		
5	401126G	RH Rest Weldment =Green=	1	
	401126R	RH Rest Weldment =Red=		
6	403076G	LH Railing Weldment =Green=	1	
	403076R	LH Railing Weldment =Red=		
7	403071G	Wing Rest Weldment =Green=	2	
	403071R	Wing Rest Weldment =Red=		
8	409254G	Platform Railing Weldment =Green=	1	
	409254R	Platform Railing Weldment =Red=		
9	411043G	Step Weldment =Green=	1	
	411043R	Step Weldment =Red=		
10	416459G	Tank Support =Green=	1	
	416459R	Tank Support =Red=		
11	9009818	Box Bolt 5/16"-18UNC Grade 8	16	
12	9405-088	Flat Washer, 1/2	52	
13	9404-029	Lock Washer, 5/8	4	
14	9390-101	Capscrew, 1/2-13UNC x 1 1/2 Grade 5	15	
15	9404-025	Lock Washer, 1/2	28	
16	9394-010	Hex Nut, 1/2-13 UNC	20	
17	9003259	Capscrew Flange, 3/8-16UNC x 1 1/4 Grade 5	10	
18	91263	Nut/Large Flange, 3/8-16UNC	12	
19	400875	Poly Rest Pad With Two Holes	2	
20	403784	Poly Rest Pad 26 3/4"	2	
21	404777	Curved Poly Rest Pad	2	
22	903171-662	Flat Head, 5/16-18UNC x 1 1/4	12	Machine Screw
23	9404-019	Lock Washer, 5/16	10	
24	9394-004	Hex Nut, 5/16-18UNC	10	
25	9390-115	Capscrew 1/2"-13UNC x 6 Grade 5	2	
26	9394-014	Hex Nut, 5/8-11UNC	4	
27	9390-103	Capscrew 1/2"-13UNC x 2"	1	
28	9390-108	Capscrew, 1/2-13UNC x 3 1/4 Grade	4	
29	9003397	Flange Nut, 1/2-13UNC	4	
30	9005689	Hose Holder	1	
31	9405-086	Flat Washer 1/2" SAE	1	
32	407738G	Handrail Weldment =Green=	1	
	407738R	Handrail Weldment =Red=		
33	91262	Screw/Large Flange, 3/8-16UNC x 1 Grade 5	2	

Gauge Panel

Please visit www.unverferth.com/parts/ for the most current parts listing.

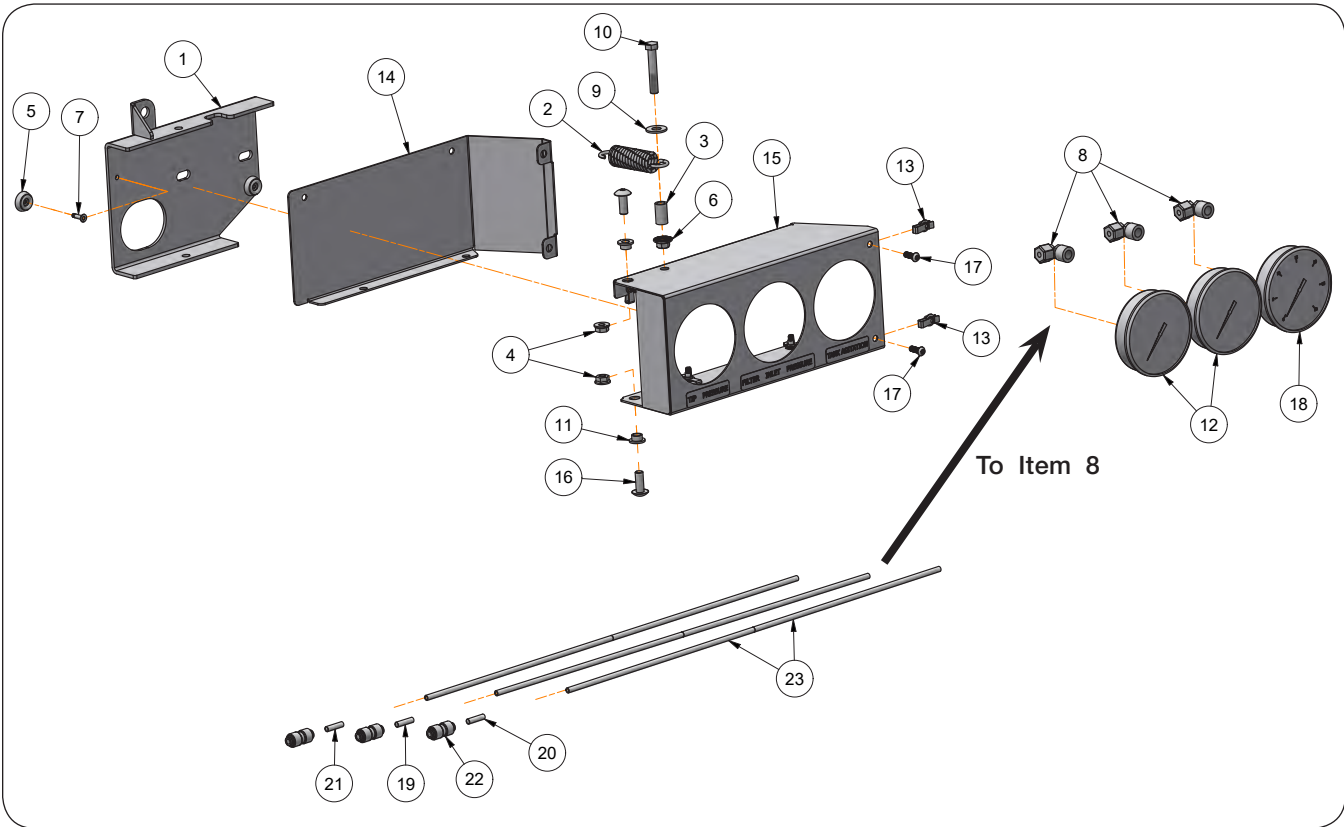

Gauge Panel

Please visit www.unverferth.com/parts/ for the most current parts listing.

ITEM	PART NO.	DESCRIPTION	QTY.	NOTES
1	401114B	Gauge Bracket Mount Weldment =Black=	1	
2	9002044	Extension Spring	1	
3	401109	Spacer Tube	1	
4	9003396	Locknut 3/8"-16UNC	2	
5	9003850	Bumper	2	
6	91263	Flange Nut, 3/8"-16UNC	1	
7	TA0-908386-0	Stainless Pop Rivet 3/8"	2	
8	TA720812	Elbow 1/4" FPT x 1/4" Tube	3	
9	9405-076	Flat Washer 3/8" USS	1	
10	9390-060	Capscrew 3/8"-16UNC x 2 1/4" Grade 5	1	
11	9003862	Washer, Shouldered 1/4"	2	
12	9007569	Pressure Gauge 0-160PSI	2	
13	TA500592	Cage Nut 1/4"-20UNC	6	
14	417964B	Gauge Cover Plate =Black=	1	
15	417960B	Gauge Bracket Weldment =Black=	1	
16	9005312	Truss Head Machine Screw 3/8"-16UNC x 1"	2	
17	9003829	Button Head Socket Screw 1/4"-20UNC x 3/4" Grade 5	6	
18	9009854	Pressure Gauge 0-30PSI	1	
19	9010007	Shrink Wrap, 1/4" Red	0.083	To Filter Inlet Pressure Gauge Specify In Feet (QTY 1" Length)
20	9010008	Shrink Wrap, 1/4" White	0.083	To Tank Agitation Pressure Gauge Specify In Feet (QTY 1" Length)
21	9010009	Shrink Wrap, 1/4" Blue	0.083	To Tip Pressure Gauge Specify In Feet (QTY 1" Length)
22	TA750171	Coupler Push To Connect, 1/4"	3	
23	TA720620	Gauge Tubing, 1/4"	6	Specify In Feet

NOTE: Remove all gauges and store indoors in an upright position to prevent freezing.

Toolbox, Side Panels & Command Center Mounting

Please visit www.unverferth.com/parts/ for the most current parts listing.

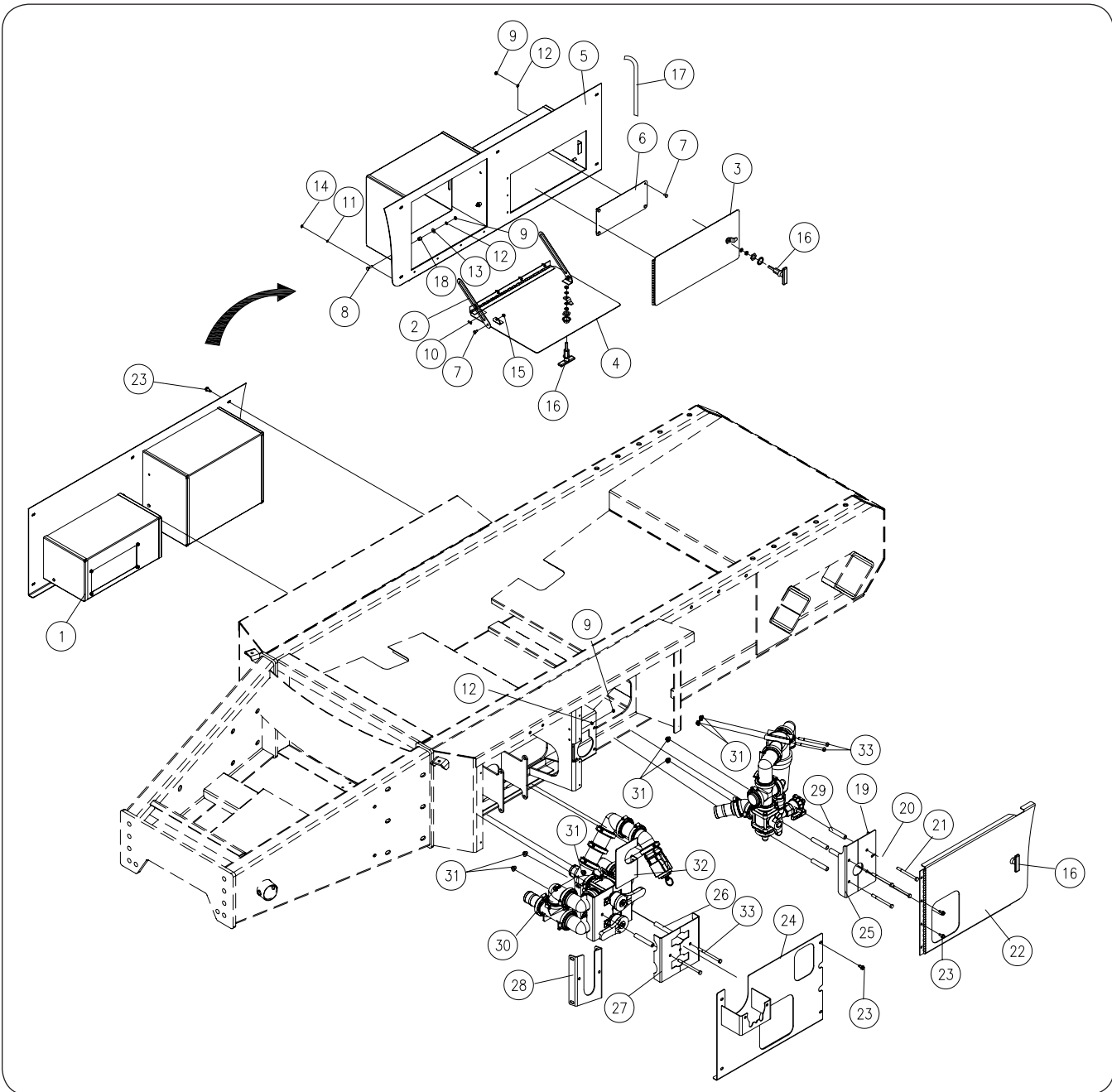

ITEM	PART NO.			DESCRIPTION	QTY.	NOTES
	1200	1600	2400			
1	404517G	404523G	403060G	Toolbox Assembly =Green=	1	
	404517R	404523R	403060R	Toolbox Assembly =Red=	1	
2	401228B	>	>	Door Stop =Black=	2	
3	401800G	>	>	Front RH Side Door Weldment =Green=	1	
	401800R	>	>	Front RH Side Door Weldment =Red=	1	

Sprayer TA1200 / TA1600 / TA2400 — Parts

Toolbox, Side Panels & Command Center Mounting

Please visit www.unverferth.com/parts/ for the most current parts listing.

ITEM	PART NO.			DESCRIPTION	QTY.	NOTES
	1200	1600	2400			
4	402809G	401801G	403061G	Rear RH Side Door Weldment =Green=	1	
	402809R	401801R	403061R	Rear RH Side Door Weldment =Red=	1	
5	403053G	403047G	403898G	RH Side Weldment =Green=	1	
	403053R	403047R	403898R	RH Side Weldment =Red=	1	
6	404647B	>	>	Cover Plate =Black=	1	
7	9390-001	>	>	Capscrew, 1/4-20UNC x 1/2	6	Grade 5
8	9390-005	>	>	Capscrew, 1/4-20UNC x 1	2	Grade 5
9	9394-002	>	>	Nut, 1/4-20UNC	8	Grade 5
10	903171-223	>	>	Flat Head Phillips Screw, #10-32UNF x 1/2	4	
11	9404-013	>	>	Lock Washer, #10	4	
12	9404-017	>	>	Lock Washer, 1/4	8	
13	9405-064	>	>	Flat Washer, 1/4	2	
14	9830-016	>	>	Nut, #10-32UNF	4	
15	9936	>	>	Locknut, 1/4-20UNC	2	
16	TA610014	>	>	T-Handle, Black	3	
17	9003757	>	>	Gasket, 1/4 x 1/2" Foam	10	Specify In Feet
18	401227	>	>	Bushing, 1/2 x 1/4 x 7/16"	2	
19	403881B	>	>	Valve Clamp Weldment, 4 1/4" Wide =Black=	1	
20	9001005	>	>	Rubber Grommet	2	
21	9390-068	>	>	Capscrew, 3/8-16UNC x 4 1/2	4	
22	403046G	-	-	Rear LH Side Door Weldment =Green=	1	
	403046R	-	-	Rear LH Side Door Weldment =Red=	1	
	-	403051G	-	Rear LH Side Door Weldment =Green=	1	
	-	403051R	-	Rear LH Side Door Weldment =Red=	1	
	-	-	403894G	Rear LH Side Door Weldment =Green=	1	
	-	-	403894R	Rear LH Side Door Weldment =Red=	1	
23	9004565	>	>	Capscrew, Flange 5/16-18UNC x 3/4	13	
24	408102G	407447G	407449G	Front LH Side Panel =Green=	1	
	408102R	407447R	407449R	Front LH Side Panel =Red=	1	
25	405110B	>	>	Valve Clamp Weldment, 3 1/4" Wide =Black=	1	
26	403858B	>	>	Bushing, Spacer, 4 3/32" =Black=	2	
27	403870B	>	>	Bracket, Valve, 9" =Black=	2	
28	403874B	>	>	Bracket, Valve, 8 3/4" =Black=	1	
29	403860B	>	>	Bushing, Spacer, 3 9/16" =Black=	4	
30	91262	>	>	Screw, Large Flange 3/8-16UNC x 1	4	Grade 5
31	91263	>	>	Nut, Large Flange 3/8-16UNC	12	Grade 5
32	403871B	>	>	Bracket, Quick Fill =Black=	1	
33	9390-069	>	>	Capscrew, 3/8-16UNC x 5	4	Grade 5
34	TA816029	>	>	Square Air Filter	1	Not Shown

Axle

Please visit www.unverferth.com/parts/ for the most current parts listing.

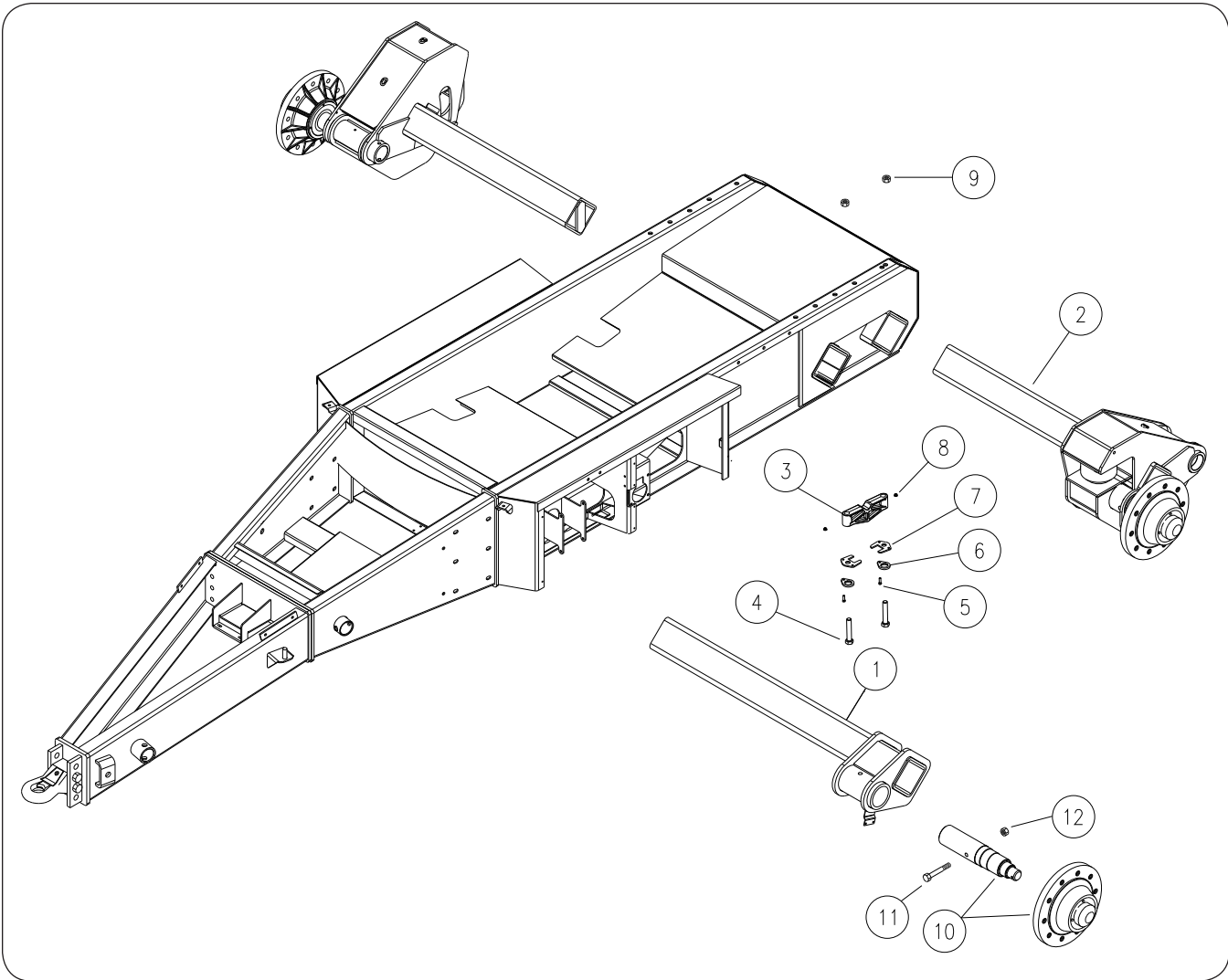

Axle

Please visit www.unverferth.com/parts/ for the most current parts listing.

ITEM	PART NO.			DESCRIPTION	QTY.	NOTES
	1200	1600	2400			
1	402642B	-	-	Axle Weldment, Non-Suspended (Black)	2	
2	402063	400752	406741	Axle Assembly, Suspended (Black)	2	See "Suspended Axle" For Parts Listing
3	404785B	>	>	Clamp =Black=	2	
4	9390-194	>	>	Capscrew, 1-8UNC x 5 1/2 Grade 5	4	
5	9390-056	>	>	Capscrew, 3/8-16UNC x 1 1/4 Grade 5	4	
6	413570B	>	>	Bolt Retainer Plate, 3 5/16" =Black=	4	
7	413569B	>	>	Bolt Retainer Plate, 3 7/8"=Black=	4	
8	9003396	>	>	Locknut, 3/8-16UNC	4	
9	9394-020	>	>	Hex Nut, 1-8UNC Grade 5	4	
10	401593B	-	-	Hub & Spindle Assembly - Non-Suspended Axle (Black)	2	See "Hub & Spindle" For Parts Listing
	400765B	>	>	Hub & Spindle Assembly - Suspended Axle (Black)	2	
11	9390-135	>	>	Capscrew, 5/8-11UNC x 5 1/2 Grade 5	2	
12	95905	>	>	Locknut, 5/8-11UNC	2	

Suspended Axle

Please visit www.unverferth.com/parts/ for the most current parts listing.

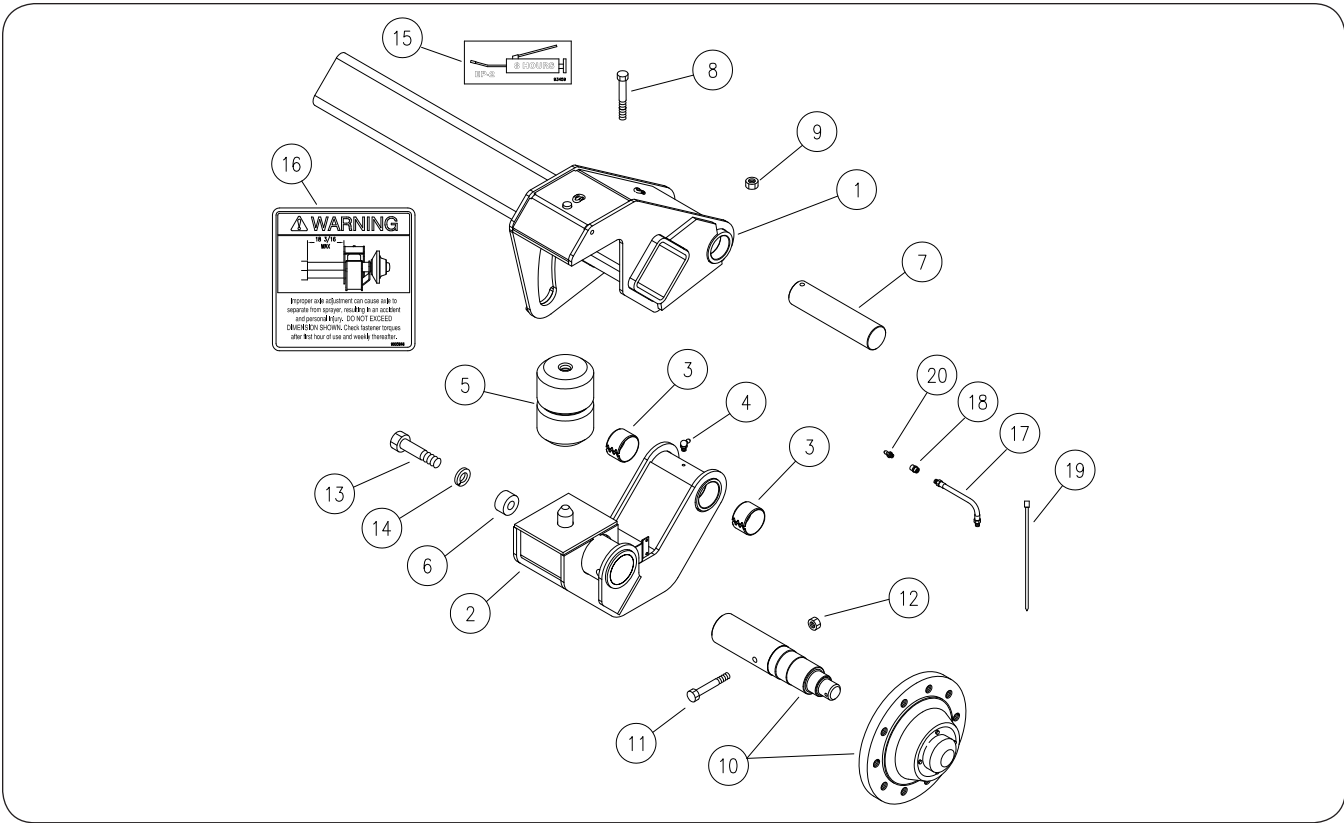

Suspended Axle

Please visit www.unverferth.com/parts/ for the most current parts listing.

ITEM	PART NO.			DESCRIPTION	QTY.	NOTES
	1200	1600	2400			
	402063	400752	406741	Axle Assembly - 120" (Black)	1	Includes Items 1-3 and 5-14
	405829	405830	-	Axle Assembly - 144" (Black)	1	
1	<	400751B	406740B	Upper Axle Weldment - 120" =Black=	1	
	<	405822B	-	Upper Axle Weldment - 144" =Black=	1	
2	<	400741B	413750B	Lower Axle Weldment =Black=	1	
3	<	9003415	>	Bushing 3 1/4 OD x 3 ID x 2	2	
4	<	9000875	>	Grease Zerk, 1/8 NPT 90°	1	
5	9004161	9003597	9004706	Spring/Rubber	1	
6	<	400707	>	Bushing 2 1/2 OD x 1 ID x 1 3/8	1	
7	<	400660	>	Pin 3" Dia. x 12 13/16	1	
8	<	9390-112	>	Capscrew, 1/2-13UNC x 4 1/2 Grade 5	1	
9	<	94981	>	Locknut, 1/2-13UNC	1	
10	<	400765B	>	Hub & Spindle Assembly (Black)	1	See "Hub & Spindle" For Parts Listing
11	<	9390-135	>	Capscrew, 5/8-11UNC x 5 1/2 Grade 5	1	
12	<	95905	>	Locknut, 5/8-11UNC	1	
13	<	9390-189	>	Capscrew, 1-8UNC x 3 1/2 Grade 5	1	
14	<	9404-041	>	Lock Washer, 1"	1	
15	<	93459	>	Decal, Grease - 8 Hours	1	
16	<	9003846	>	Decal, WARNING Axle Adjustment	1	
17	<	9003830	>	Hose, 3/16" x 24" (1/8" NPT)	1	
18	<	9003949	>	Pipe Coupling, 1/8 NPT	1	
19	<	9000107	>	Plastic Tie, 15 1/2"	1	
20	<	93426	>	Grease Zerk, 1/8 NPT	1	

Hub & Spindle

Please visit www.unverferth.com/parts/ for the most current parts listing.

NOTE: For Hub Hardware, Refer To
"Wheels & Tires" For Parts List

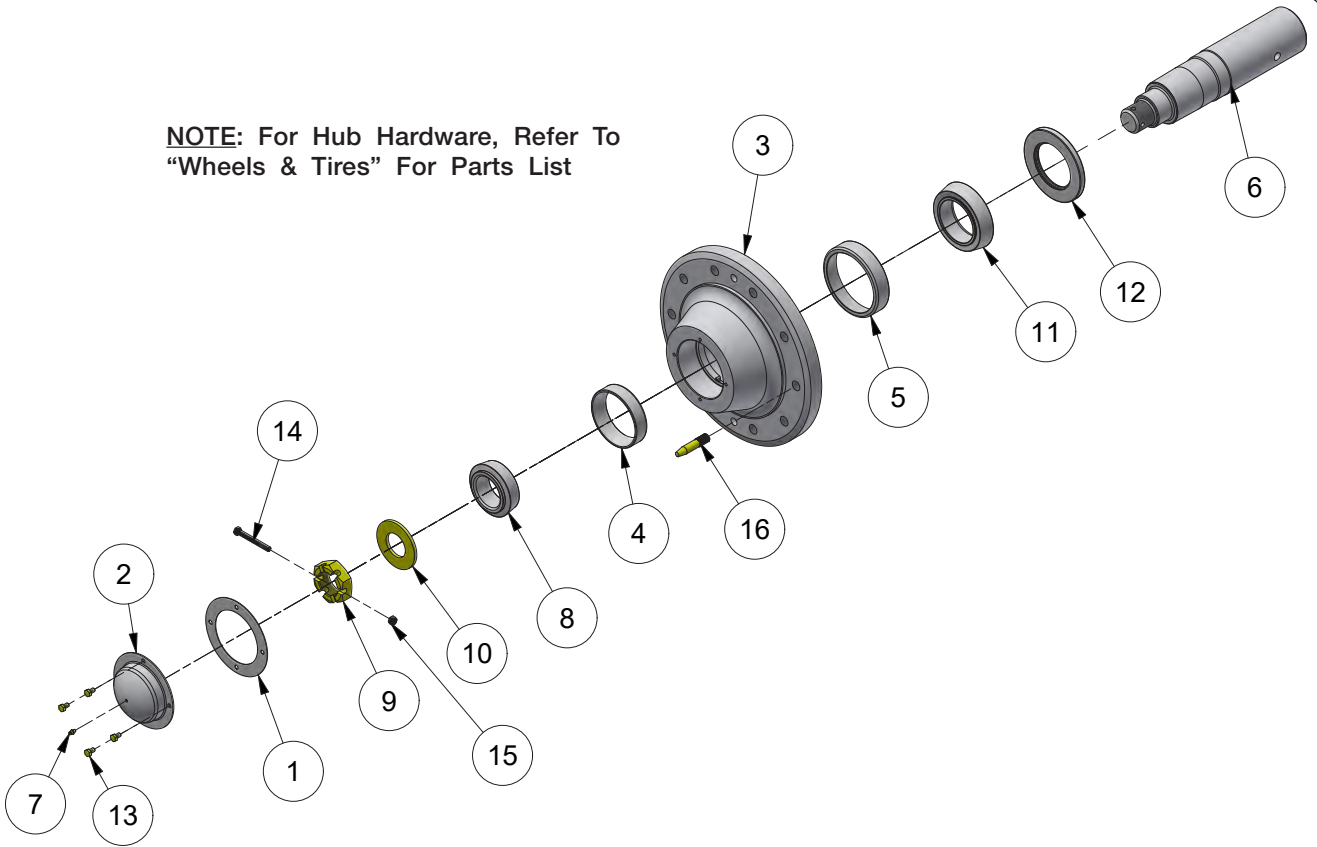

Hub & Spindle

Please visit www.unverferth.com/parts/ for the most current parts listing.

ITEM	PART NO.			DESCRIPTION	QTY.	NOTES
	1200	1600	2400			
	401593B Standard Axle	400765B Suspended Axle	400765B Suspended Axle	Hub & Spindle Assembly (Black)	1	10 Bolt Hub w/ 3 3/4" Spindle Includes Items 1-15
1	284230	>	>	Hub Cap Gasket, 6 1/2" Dia.	1	
2	286171B	>	>	Hub Cap w/Hole =Black=	1	
3	401144B	>	>	Hub w/Cups =Black=	1	Includes Items 4 & 5
4	92462	>	>	Outer Bearing Cup	1	HM212011
5	92476	>	>	Inner Bearing Cup	1	HM218210
6	401580	400743	400743	Spindle 3 3/4" Dia.	1	
7	91160	>	>	Grease Zerk	1	
8	92464	>	>	Outer Bearing Cone	1	HM212049
9	92470	>	>	Castle Nut 2-12UNF Gr. 5	1	
10	92472	>	>	Spindle Washer 2 1/16" ID	1	
11	92545	>	>	Inner Bearing Cone	1	HM218248
12	92565	>	>	Seal 3.685 ID	1	75014036
13	9390-026	>	>	Capscrew 5/16-18UNC x 1/2 Gr. 5	4	
14	9390-064	>	>	Capscrew 3/8"-16UNC x 3 1/4" Gr. 5	1	
15	902875	>	>	Locknut, 3/8"-16UNC	1	
16	19293	>	>	Guide Pin, .625" Dia. x 3.125"	1	

Wheels & Tires - Models 1200 / 1600

Please visit www.unverferth.com/parts/ for the most current parts listing.

EXTENSIONS

3" HUB EXTENSION

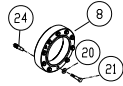

5" HUB EXTENSION

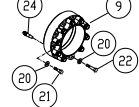

6" HUB EXTENSION

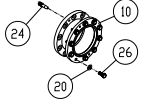

8" HUB EXTENSION

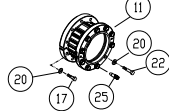

SINGLES

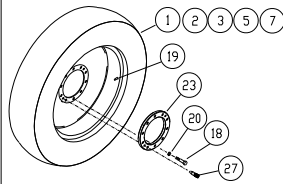

NOTE: See "Wheels and Tires" In MAINTENANCE Section For Torque Information.

TIRES

For questions regarding new tire warranty, please contact your local original equipment tire dealer. Used tires carry no warranty. Tire manufacturers' phone numbers and websites are listed in the Maintenance Section for your convenience.

DUALS

30" DUAL SPACING

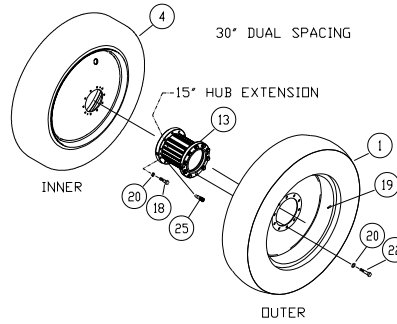

30" DUAL SPACING

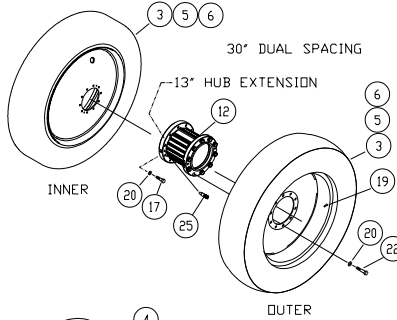

36" DUAL SPACING

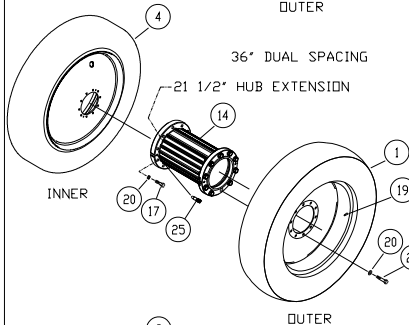

24" DUAL SPACING

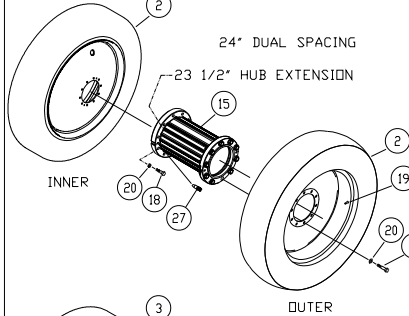

44" DUAL SPACING

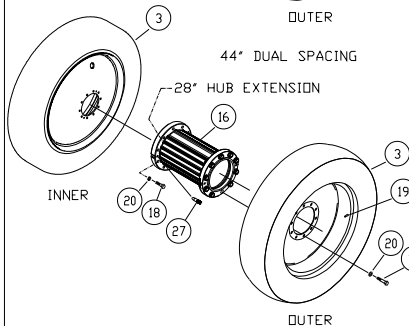

Wheels & Tires - Models 1200 / 1600

Please visit www.unverferth.com/parts/ for the most current parts listing.

ITEM	PART NO.	DESCRIPTION	QTY.	NOTES
1	16477SM/902519	Wheel & Tire Assembly =Silver Mist=	1	TL380/90R46MT R-1W
	16477SM	Wheel Only =Silver Mist=	1	13 x 46 10 Hole
2	16376SM/99213	Wheel & Tire Assembly =Silver Mist=	1	TL480/80R42F R-1
	16369SM	Wheel Only =Silver Mist=	1	16 x 42 10 Hole
3	17142SM/9501538	Wheel & Tire Assembly =Silver Mist=	1	TL320/90R50MT R-1W
	17142SM	Wheel Only =Silver Mist=	1	10 x 50 10 Hole
4	16366SM/902519	Wheel & Tire Assembly =Silver Mist=	1	TL380/90R46 R-1W
	16366SM	Wheel Only =Silver Mist=	1	13 x 46 10 Hole
5	16648SM/9501416	Wheel & Tire Assembly =Silver Mist=	1	TL 320/95R46 R-1W
	16648SM	Wheel Only =Silver Mist=	1	10 x 46 10 Hole
6	17104SM	Wheel & Tire Assembly =Silver Mist=	1	TL 270/95R48A R-1
	17103SM	Wheel Only =Silver Mist=	1	10 x 48 10 Hole
7	111190SM/99299	Wheel & Tire Assembly =Silver Mist=	1	TL 320/90R42 R-1W
	111190SM	Wheel Only =Silver Mist=	1	10 x 42 10 Hole

(Continued on next page)

Sprayer TA1200 / TA1600 / TA2400 — Parts

Wheels & Tires - Models 1200 / 1600 (continued)

Please visit www.unverferth.com/parts/ for the most current parts listing.

ITEM	PART NO.	DESCRIPTION	QTY.	NOTES
Extensions (2 Per Unit)				
8	404792B	Hub Extension 3" Kit =Black=	1	Used With 320/90R46 & 320/90R50 20" Rows Includes Hub & Hardware
9	403201B	Hub Extension 5" Kit =Black=	1	Used With 320/90R46 22" Rows Includes Hub & Hardware
10	17540B	Hub Extension 6" Kit =Black=	1	Includes Hub & Hardware
11	404791B	Hub Extension 8" Kit =Black=	1	Used With 380/90R46 22" Rows Includes Hub & Hardware
12	402863B	Hub Extension 13" Kit =Black=	1	Used With 320/90R46 30" Rows Includes Hub & Hardware
13	404789B	Hub Extension 15" Kit =Black=	1	Used With 380/90R46 30" Rows Includes Hub & Hardware
14	404790B	Hub Extension 21 1/2" Kit =Black=	1	Used With 380/90R46 36" Rows Includes Hub & Hardware
15	18070B	Hub Extension 23 1/2" Kit =Black=	1	
16	19242B	Hub Extension 28" Kit =Black=	1	
Hardware (QTY For One Side Of Unit)				
17	97043	Wheel Bolt, 7/8-14UNF x 4 Grade 8	10	For 8", 13" & 21 1/2" Hub Extensions (Inner Side)
18	97042	Wheel Bolt, 7/8-14UNF x 3 1/2 Grade 8	10	For 15" Hub Extension & Singles
			20	For 23 1/2" & 28" Hub Extensions
19	93300	Valve Stem	1	Singles
			2	Duals
20	97041	Flat Washer, 7/8	10	Singles
			20	Duals
21	9004138	Capscrew, 7/8-14UNF x 6 Grade 8	10	For 3" & 5" Hub Extensions
22	95657	Capscrew, M22 x 2.5P x 65 C10.9	10	For 5", 8", 13", 15" & 21 1/2" Hub Extensions Full Threaded
23	14442SM	Reinforcing Ring =Silver Mist=	1	Singles
24	266459	Guide Pin 7/8" Dia.	1	For 3", 5" & 6" Hub Extensions
25	19293	Guide Pin 5/8" Dia. (3.125 Lg.)	2	For 8", 13", 15" & 21 1/2" Hub Extensions
26	91593	Capscrew, M22 x 2.5P x 50 C10.9	10	For 6" Hub Extension
27	10041	Guide Pin, 5/8" DIA. (2.625 Lg.)	1	Singles
			2	Duals

Notes

Blank area for notes.

Wheels & Tires - Model 2400

Please visit www.unverferth.com/parts/ for the most current parts listing.

EXTENSIONS

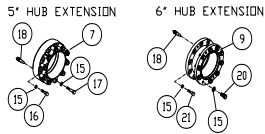

SINGLES

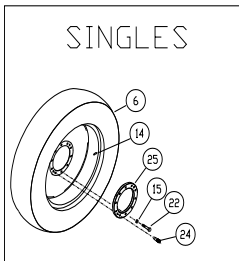

NOTE: See “Wheels and Tires” In MAINTENANCE Section For Torque Information.

TIRES

For questions regarding new tire warranty, please contact your local original equipment tire dealer. Used tires carry no warranty. Tire manufacturers' phone numbers and websites are listed in the Maintenance Section for your convenience.

DUALS

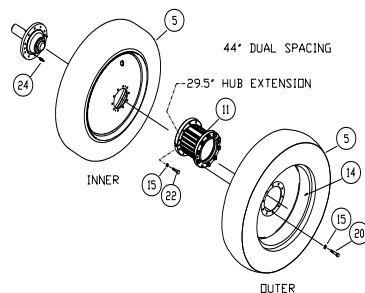
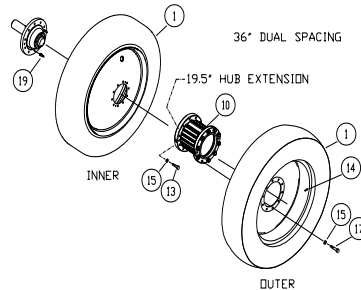
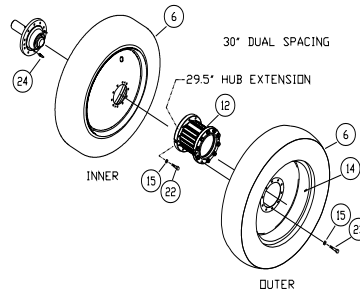
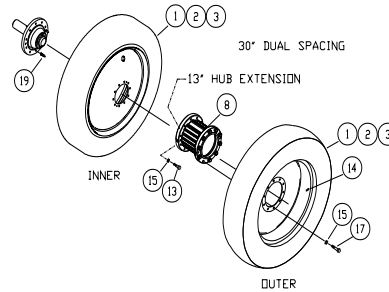
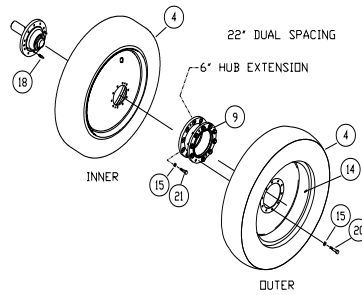

Wheels & Tires - Model 2400

Please visit www.unverferth.com/parts/ for the most current parts listing.

ITEM	PART NO.	DESCRIPTION	QTY.	NOTES
1	17075SM/9501418	Wheel & Tire Assembly =Silver Mist=	1	TL380/90R54 R-1W
	17075SM	Wheel Only =Silver Mist=	1	12 x 54 10 Hole
2	14955SM/96208	Wheel & Tire Assembly =Silver Mist=	1	TL380/90R50 R-1W
	14955SM	Wheel Only =Silver Mist=	1	12 x 50 10 Hole
3	17210SM/902535	Wheel & Tire Assembly =Silver Mist=	1	TL 480/80R50 R-1W
	17210SM	Wheel Only =Silver Mist=	1	15 x 50 10 Hole
4	17142SM/9501538	Wheel & Tire Assembly =Silver Mist=	1	TL320/90R50A R-1W
	17142SM	Wheel Only =Silver Mist=	1	10 x 50 10 Hole
5	111467SM/9503470	Wheel & Tire Assembly =Silver Mist=	1	TLVF320/105R54
	12782SM	Wheel Only =Silver Mist=	1	10 x 54 10 Hole
6	17466SM/902506	Wheel & Tire Assembly =Silver Mist=	1	650/65R42 R-1W
	17466SM	Wheel Only =Silver Mist=	1	20 x 42 10 Hole
Extensions (2 Per Unit)				
7	16383B	Hub Extension, 5" =Black=	1	Used for 22" Rows with 380/90R54 & 380/105R50 Includes Hub & Hardware
	403201B	Extension Kit, 5" =Black=	1	Includes Hub & Hardware
8	16967B	Hub Extension, 13" =Black=	1	Used for 30" Rows with 380/90R54 Includes Hub & Hardware
	402863B	Extension Kit, 13" =Black=	1	Includes Hub & Hardware
9	17540B	Hub Extension 6" Kit =Black=	1	Includes Hub & Hardware
10	18875B	Hub Extension 19.5" Kit =Black=	1	Used for 36" Rows with 380/90R54
11	14961B	Hub Extension 29.5" Kit =Black=	1	Includes Hub & Hardware
12	14960B	Hub Extension 29.5" Kit =Black=	1	
Hardware (QTY For One Side Of Unit)				
13	97043	Wheel Bolt, 7/8-14UNF x 4 Grade 8	10	For 13" & 19.5" Hub Extensions
14	93300	Valve Stem	1	Singles
			2	Duals
15	97041	Flat Washer, 7/8	10	Singles
			20	Duals
16	9004543	Capscrew, 7/8-14UNF x 5 1/2 Grade 8	10	For 5" & 6" Hub Extension
17	95657	Capscrew, M22 x 2.5P x 65 C10.9	10	For 5", 13" & 19.5" Hub Extensions Full Threaded
18	266459	Guide Pin 7/8" Dia.	1	For 5" & 6" Hub Extensions
19	19293	Guide Pin 5/8" Dia. (3.125 Lg.)	2	For 13", 19.5" & 29.5" Hub Extensions
20	91593	Capscrew, M22 x 2.5P x 50 C10.9	10	
21	96780	Capscrew, 7/8-14UNF x 3 Grade 8	10	For 6" Hub Extension
22	97042	Capscrew, 7/8-14UNF x 3 1/2 Grade 8	10	For 29.5" Hub Extension & Singles
23	97726	Capscrew, M22 x 2.5P x 60 C10.9	10	
24	10041	Guide Pin, 5/8" DIA. (2.625 Lg.)	1	Singles
			2	For 29.5" Hub Extension Duals
25	14442SM	Reinforcing Ring =Silver Mist=	1	

Equalizer® Track Components - Model 1600

Please visit www.unverferth.com/parts/ for the most current parts listing.

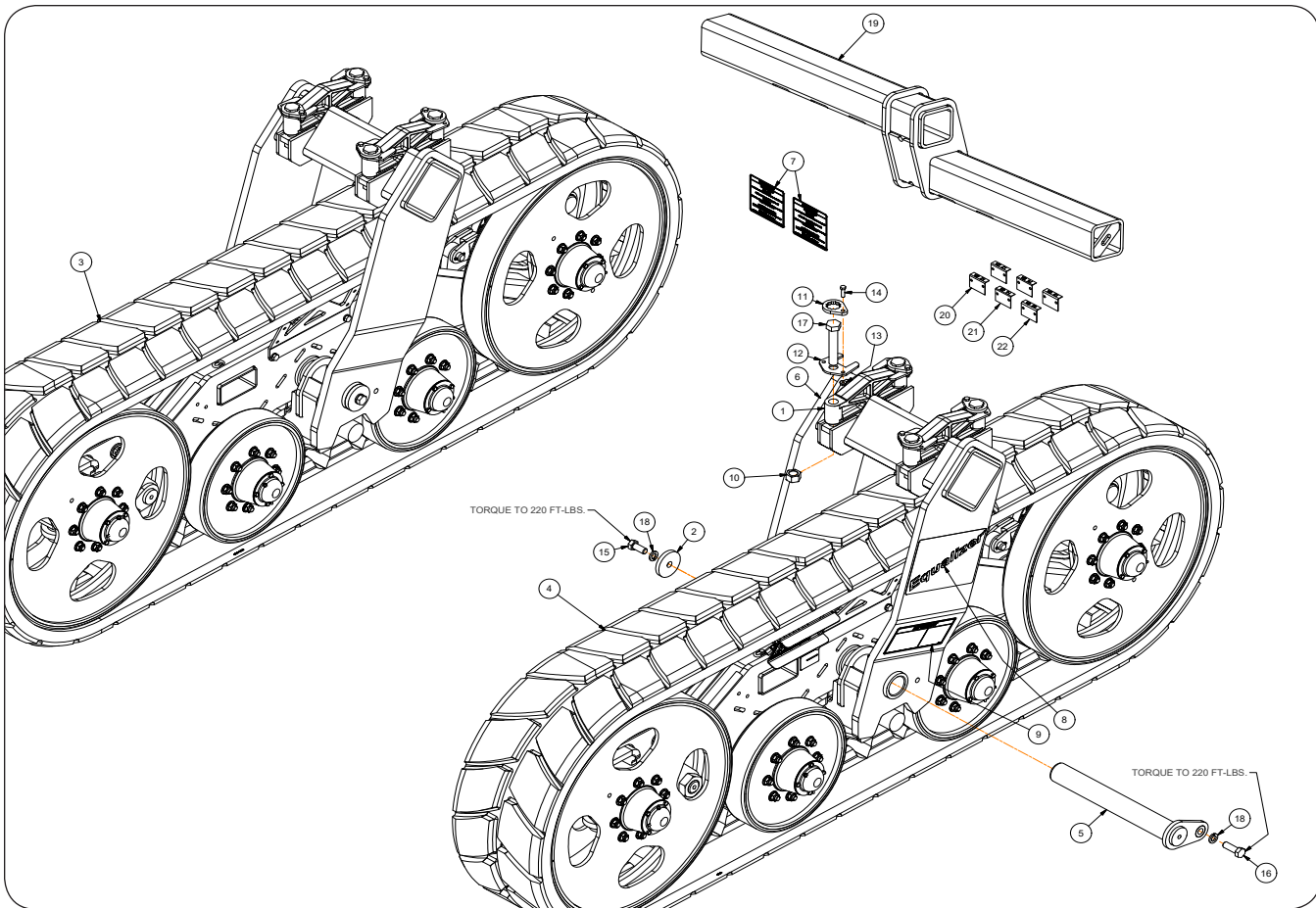

ITEM	PART NO.	DESCRIPTION	QTY.	NOTES
1	404785B	Axle Clamp =Black=	4	
2	408646	Pin Retainer Plate	2	
3	409132B	Track Assembly, Right-Hand =Black=	1	
4	409133B	Track Assembly, Left-Hand =Black=	1	
5	411223	Pivot Pin Weldment	2	
6	411250B	Track Fork Weldment =Black=	2	
7	9007523	Decal, Important Track Guidelines	2	
8	9007564	Decal, Equalizer	2	
9	9007616	Decal, Important Track Grease	2	
10	9394-020	Center Locknut, 1-8UNC	8	
11	413570B	Bolt Retainer Plate 3 5/16" =Black=	8	
12	413569B	Bolt Retainer Plate 3 7/8" =Black=	8	
13	9003396	Locknut, 3/8-16UNC	8	
14	9390-056	Capscrew, 3/8-16UNC x 1 1/4 Gr.5	8	
15	9390-144	Capscrew, 3/4-10UNC x 1 3/4 Gr.5	2	
16	9390-146	Capscrew, 3/4-10UNC x 2 1/4 Gr.5	2	
17	9390-194	Capscrew, 1-8UNC x 5 1/2 Gr.5	8	
18	9404-033	Lock Washer, 3/4 #10	4	
19	411116B	Axle Weldment =Black=	2	
20	411098B	12 Gauge Shim =Black=	2	
21	411103B	14 Gauge Shim =Black=	2	
22	411105B	10 Gauge Shim =Black=	2	

Equalizer® Track Components - Model 2400

Please visit www.unverferth.com/parts/ for the most current parts listing.

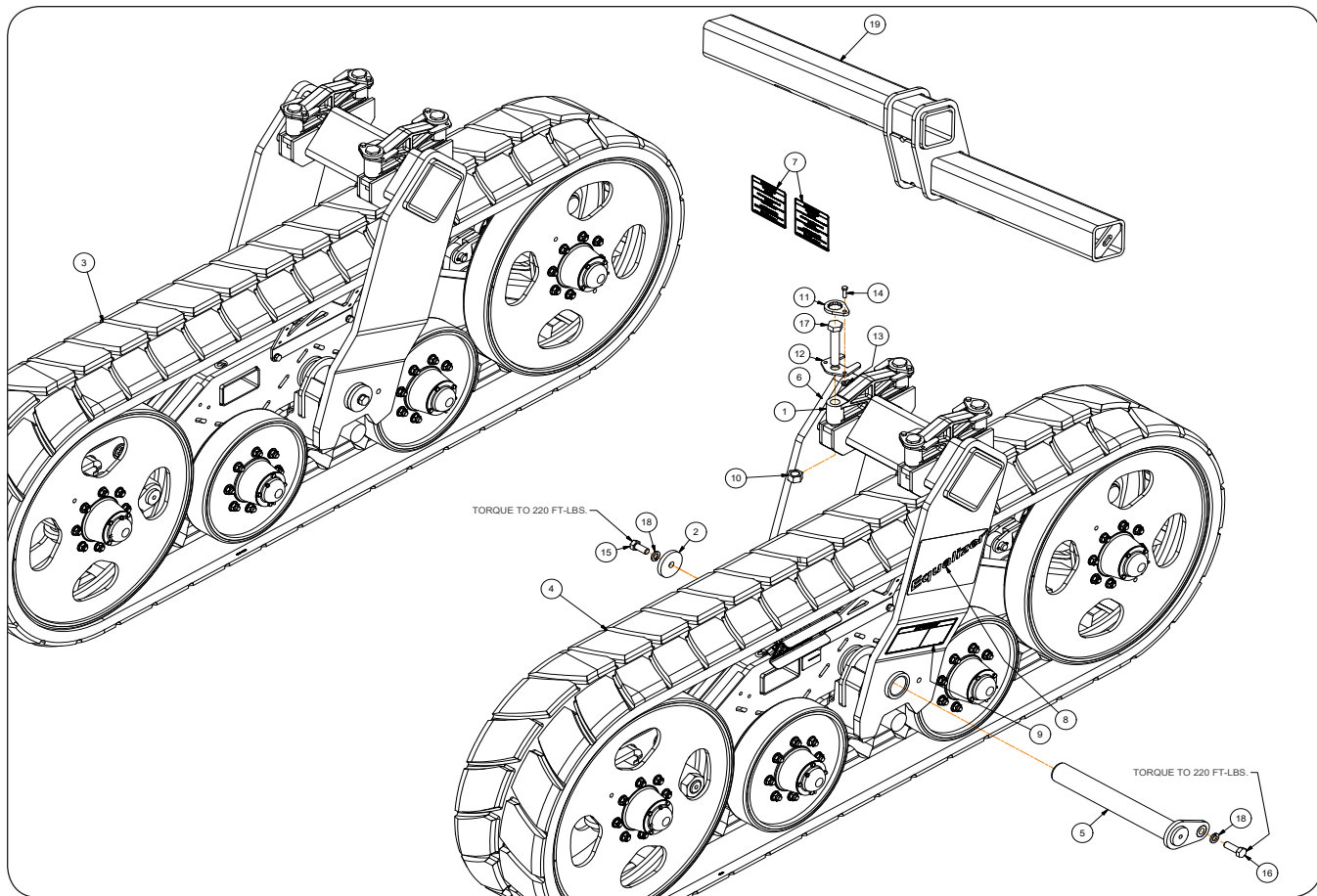

ITEM	PART NO.	DESCRIPTION	QTY.	NOTES
1	404785B	Axle Clamp =Black=	4	
2	408646	Pin Retainer Plate	2	
3	409132B	Track Assembly, Right-Hand =Black=	1	
4	409133B	Track Assembly, Left-Hand =Black=	1	
5	411223	Pivot Pin Weldment	2	
6	411217B	Track Fork Weldment =Black=	2	
7	9007523	Decal, Important Track Guidelines	2	
8	9007564	Decal, Equalizer	2	
9	9007616	Decal, Important Track Grease	2	
10	9394-020	Center Locknut, 1-8UNC	8	
11	413570B	Bolt Retainer Plate 3 5/16" =Black=	8	
12	413569B	Bolt Retainer Plate 3 7/8" =Black=	8	
13	9003396	Locknut, 3/8-16UNC	8	
14	9390-056	Capscrew, 3/8-16UNC x 1 1/4 Gr.5	8	
15	9390-144	Capscrew, 3/4-10UNC x 1 3/4 Gr.5	2	
16	9390-146	Capscrew, 3/4-10UNC x 2 1/4 Gr.5	2	
17	9390-194	Capscrew, 1-8UNC x 5 1/2 Gr.5	8	
18	9404-033	Lock Washer, 3/4 #10	4	
19	409324B	Axle Weldment =Black=	2	

Mast

Please visit www.unverferth.com/parts/ for the most current parts listing.

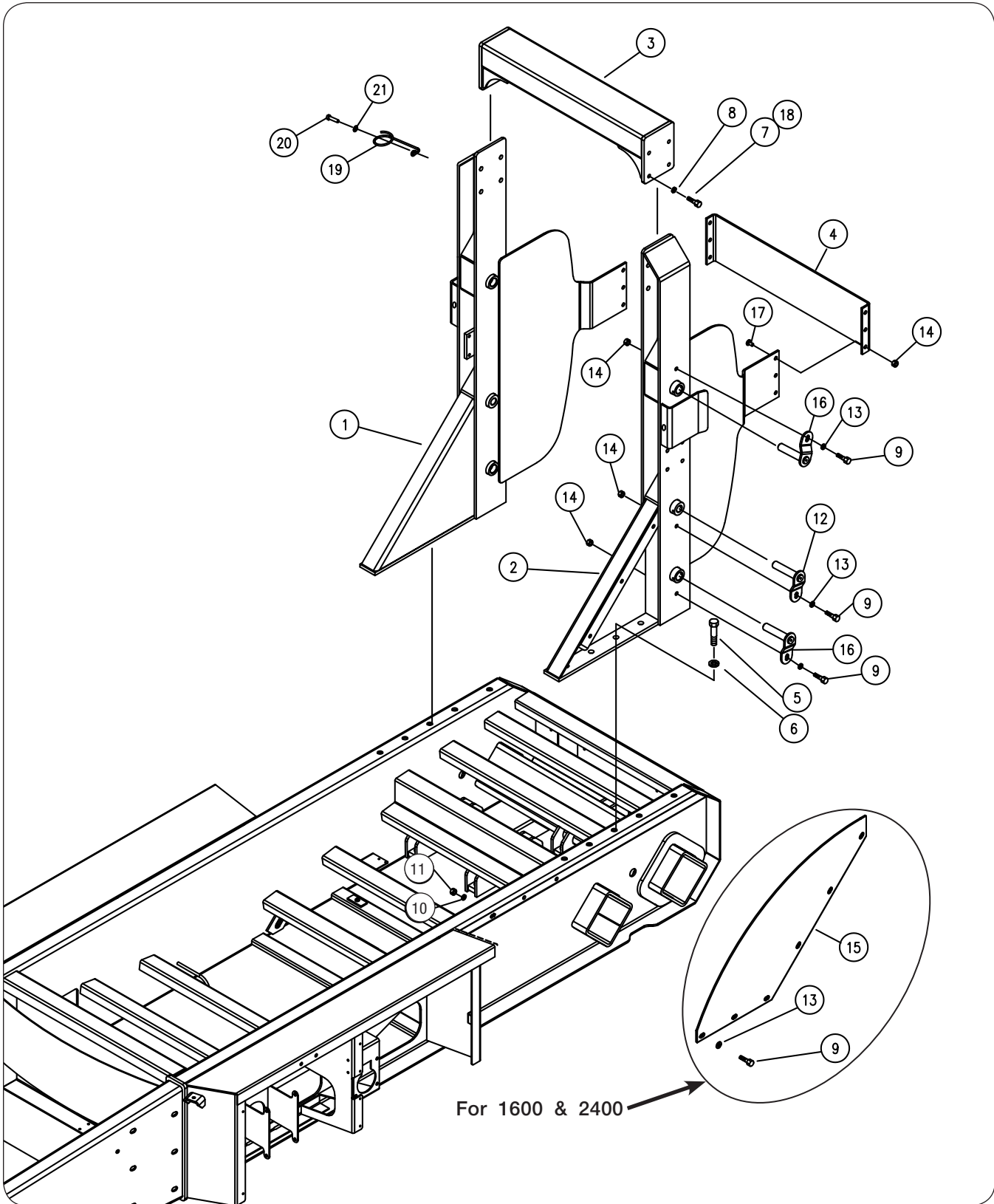

Sprayer TA1200 / TA1600 / TA2400 — Parts

Mast

Please visit www.unverferth.com/parts/ for the most current parts listing.

ITEM	PART NO.			DESCRIPTION	QTY.	NOTES
	1200	1600	2400			
1	402089G	400679G	402698G	RH Mast Weldment =Green=	1	
	402089R	400679R	402698R	RH Mast Weldment =Red=	1	
2	402090G	400680G	402699G	LH Mast Weldment =Green=	1	
	402090R	400680R	402699R	LH Mast Weldment =Red=	1	
3	401239G	>	>	Cross Tube Weldment =Green=	1	
	401239R	>	>	Cross Tube Weldment =Red=	1	
4	401852G	>	>	Rear Bracket =Green=	1	
	401852R	>	>	Rear Bracket =Red=	1	
5	9390-145	>	>	Capscrew, 3/4-10UNC x 2 Grade 5	10	
6	9404-033	>	>	Lock Washer, 3/4	10	
7	9390-121	>	>	Capscrew, 5/8-11UNC x 1 1/4 Grade 5	6	
8	9404-029	>	>	Lock Washer, 5/8	8	
9	9390-100	>	>	Capscrew, 1/2-13UNC x 1 1/4 Grade 5	*6 / 12	*For 1200
10	-	9404-025	>	Lock Washer, 1/2	12	For 1600 & 2400
11	-	9394-010	>	Hex Nut, 1/2-13UNC Grade 5	12	
12	402072	>	>	Flag Pin Weldment, 1"	2	
13	9405-088	>	>	Flat Washer, 1/2	*6 / 12	*For 1200
14	94981	>	>	Locknut, 1/2-13UNC	6	
15	-	401844G	-	Plate, Fender =Green=	2	
	-	401844R	-	Plate, Fender =Red=	2	
	-	-	405119G	LH Fender Weldment =Green=	1	
	-	-	405119R	LH Fender Weldment =Red=	1	
	-	-	405118G	RH Fender Weldment =Green=	1	
	-	-	405118R	RH Fender Weldment =Red=	1	
16	402071	>	>	Flag Pin Weldment, 1 1/4"	4	
17	9388-102	>	>	Carriage Bolt 1/2-13UNC x 1 G5	6	
18	9390-122	>	>	Capscrew 5/8-11UNC x 1 1/2 G5	2	
19	9005689	>	>	Hose Holder	1	
20	9390-102	>	-	Capscrew, 1/2"-13UNC x 1 3/4" G5	1	
	-	-	9390-103	Capscrew, 1/2"-13UNC x 2" G5	1	
21	9405-086	>	>	Flat Washer, 1/2" SAE	1	

Lift Assembly, H-Frame

Please visit www.unverferth.com/parts/ for the most current parts listing.

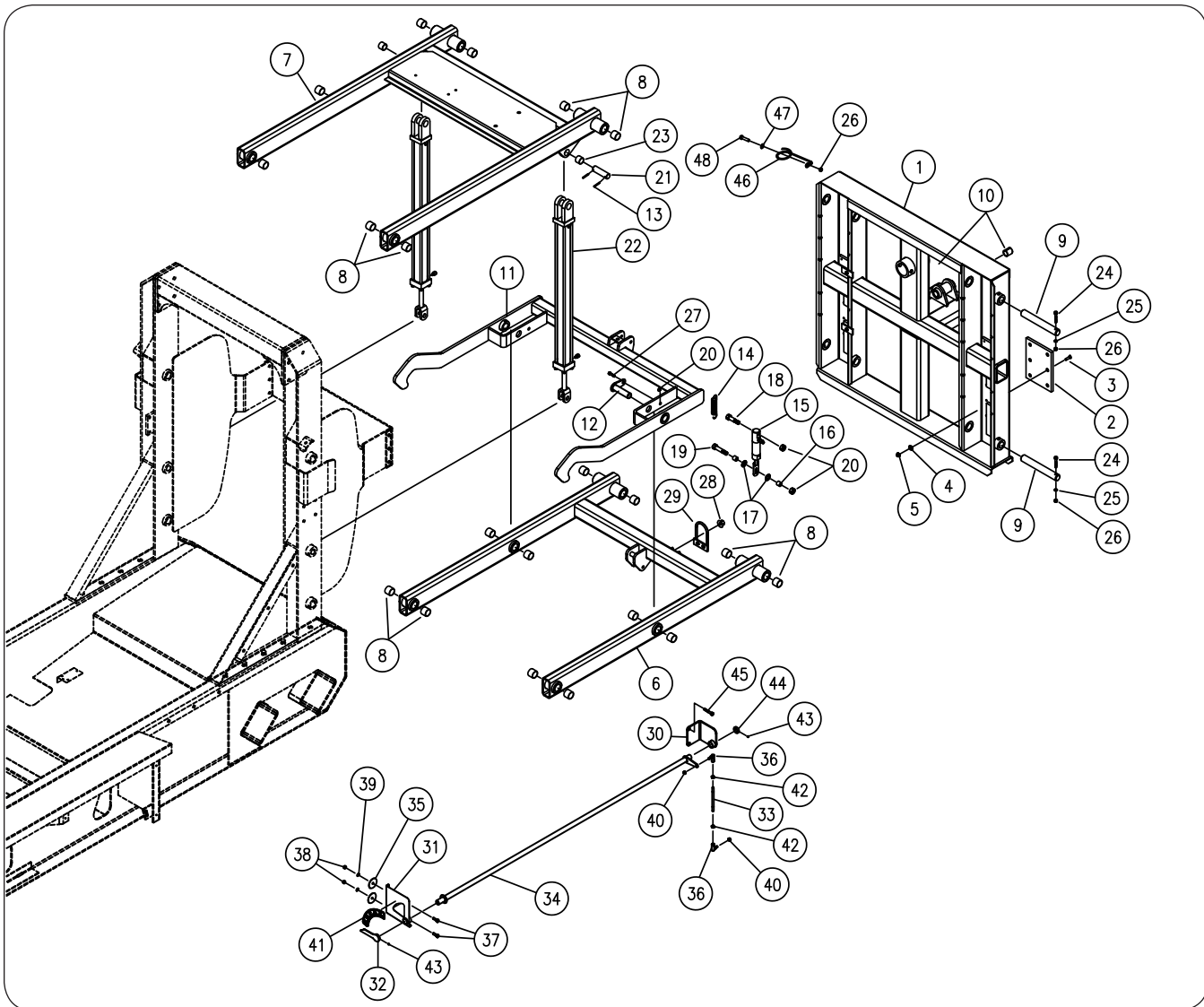

ITEM	PART NO.		DESCRIPTION	QTY.	NOTES
	60'/80'/90'/100' Booms	110'/120'/132' Booms			
1	413809G	413807G	H-Frame Weldment =Green=	1	
	413809R	413807R	H-Frame Weldment =Red=		
2	401099	407298	Pad	2	
3	900907-640	903171-660	Flat Head Screw, 5/16-18UNC x 1	12	
4	-	9404-019	Lock Washer, 5/16	12	
5	9005639	-	Serrated Flange Nut, 5/16-18UNC	12	
	-	9394-004	Hex Nut, 5/16-18UNC		
6	411003G	411004G	Lower Parallel Lift Weldment =Green=	1	
	411003R	411004R	Lower Parallel Lift Weldment =Red=		
7	408534G	408923G	Upper Parallel Lift Weldment =Green=	1	
	408534R	408923R	Upper Parallel Lift Weldment =Red=		
8	9003828	>	Self-Lubricating Bushing, 1 1/4 x 1	20	
9	401071	>	Pin	4	
10	9003440	>	Self-Lubricating Bushing, 1 1/8 x 1	2	

Sprayer TA1200 / TA1600 / TA2400 — Parts

Lift Assembly, H-Frame

Please visit www.unverferth.com/parts/ for the most current parts listing.

ITEM	PART NO.		DESCRIPTION	QTY.	NOTES
	60'/80'/90'/100' Booms	110'/120'/132' Booms			
11	401216G	>	Lock Weldment =Green=	1	
	401216R	>	Lock Weldment =Red=		
12	404766	>	Pin Weldment	2	
13	9392-140	>	Roll Pin, 1/4 x 2	4	
14	9004436	>	Extension Spring	1	
15	9005606	>	Latching Ram Cylinder	1	
16	400251	>	Bushing, 3/4 x .56 x .69	2	
17	9405-088	>	Flat Washer, 1/2	4	
18	9390-107	>	Capscrew, 1/2-13UNC x 3 Gr.5	1	
19	9390-109	>	Capscrew, 1/2-13UNC x 3 1/2 Gr.5	1	
20	94981	>	Locknut, 1/2-13UNC	4	
21	804572	>	Pin, Upper Cylinder	2	
22	9003680	-	Cylinder, 2 x 24	2	Seal Kit# 9003105
	-	9004462	Cylinder, 2-1/2 x 24	2	Seal Kit# 9004489
23	95122	>	Tension Bushing, 1 1/4 x 1 x 3/4	2	
24	9390-061	>	Capscrew, 3/8-16UNC x 2 1/2 Grade 5	3	
25	9404-021	>	Lock Washer, 3/8	2	Model 2400
26	9928	>	Locknut, 3/8-16UNC	4	
27	9390-100	>	Capscrew, 1/2-13UNC x 1 1/4 Grade 5	2	
28	91263	>	Large Flange Nut, 3/8-16UNC Grade 5	2	
29	401848B	>	Hose Hanger Weldment =Black=	1	
30	405836B	>	Indicator Rear Bracket =Black=	1	
31	405843B	>	Indicator Front Bracket =Black=	1	
32	405845R	>	Indicator Needle =Red=	1	
33	405849	>	Link Rod	1	Model 1200
	405853	>	Link Rod		Model 1600
	405842	>	Link Rod		Model 2400
34	405850B	>	Indicator Pipe =Black=	1	Model 1200
	405839B	>	Indicator Pipe =Black=		Model 1600
	406096B	>	Indicator Pipe =Black=		Model 2400
35	9004497	>	Fender Washer 3/8	32	
36	9004585	>	Ball Joint	2	
37	900900-056	>	Capscrew, 3/8-16UNC x 1 1/4 SS	2	
38	900901-006	>	Hex Nut, 3/8-16UNC SS	2	
39	900903-021	>	Lock Washer, 3/8 SS	2	
40	TA91148	>	Locknut, 3/8-24UNF	2	
41	9004722	>	Indicator Decal	1	
42	9394-005	>	Hex Nut, 3/8-24UNF	2	
43	9399-057	>	Setscrew 1/4-20UNF x 1/4	2	Cup Point/Hex Socket
44	405847B	>	Retaining Bushing =Black=	1	
45	9390-122	>	Capscrew, 5/8"-11UNC x 1 1/2" G5	2	
46	9006039	>	Hose Holder	1	
47	9006212	>	Flat Washer, 3/8" Stainless Steel	1	
48	9390-063	>	Capscrew, 3/8"-16UNC x 3" G5	1	

Command Center 4 Components

Please visit www.unverferth.com/parts/ for the most current parts listing.

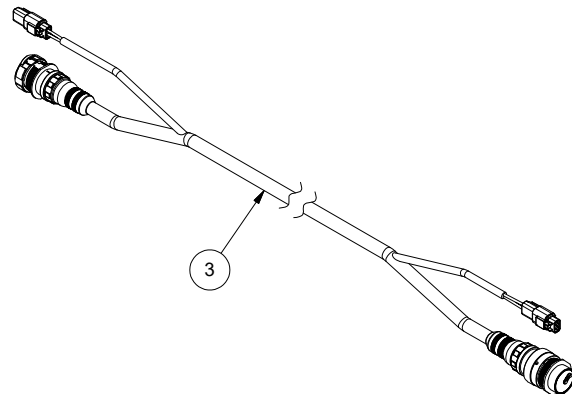
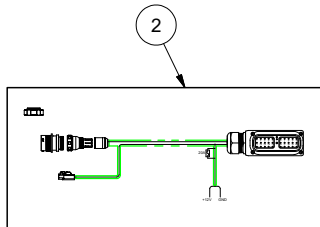
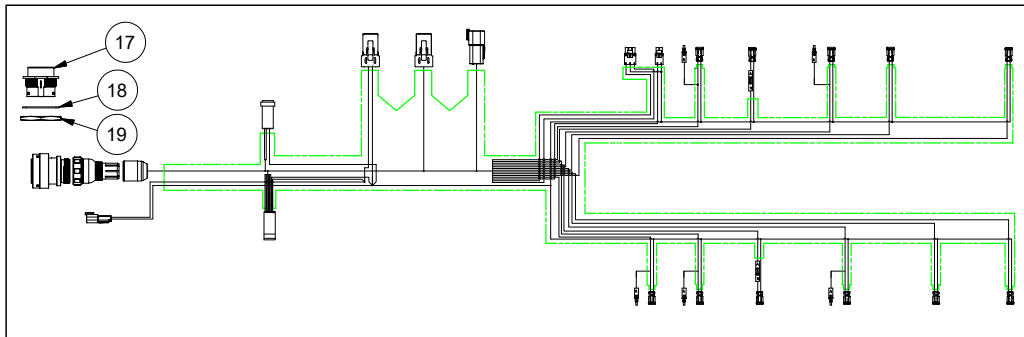
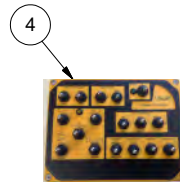
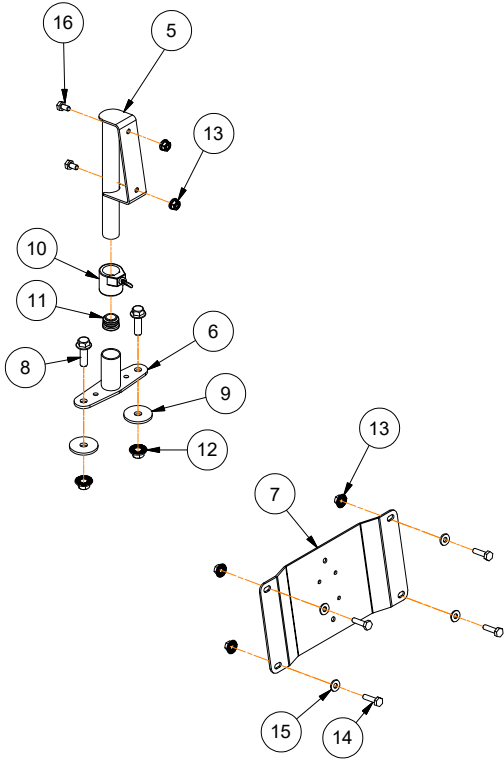

Command Center 4 Components

Please visit www.unverferth.com/parts/ for the most current parts listing.

ITEM	PART NO.	DESCRIPTION	QTY.	NOTES
1	9007773	Main Harness	1	
2	9007774	Switch Box Console Harness	1	
3	9007792	Extension Harness 120"	1	(Optional For Item 4)
4	9007776	Switch Box	1	
5	407802B	Control Box Bracket Weldment, 7 5/8" =Black=	1	
6	407805B	Control Box Bracket Weldment, 5" Wide =Black=	1	
7	411911B	Controller Plate-Bracket =Black=	1	
8	9003259	Flange Screw 3/8"-16UNC x 1 1/4"	2	
9	9005696	Fender Washer 3/8"	2	
10	9005888	Adjuster Tube	1	
11	9005889	Finishing Plug	1	
12	91263	Large Flange Nut 3/8"-16UNC	2	
13	97189	Large Flange Hex Nut 1/4"-20UNC	6	
14	9390-005	Capscrew 1/4"-20UNC x 1"	4	
15	9405-062	Flat Washer 1/4" SAE	4	
16	9390-003	Capscrew 1/4"-20UNC x 3/4"	6	
17	9006887	Deutsch Connector Cap	1	
18	9006886	Lockwasher Size 24	1	
19	9006885	Panel Nut Size 24	1	

Command Center 4 Components (Optional Wireless Boom Control)

Please visit www.unverferth.com/parts/ for the most current parts listing.

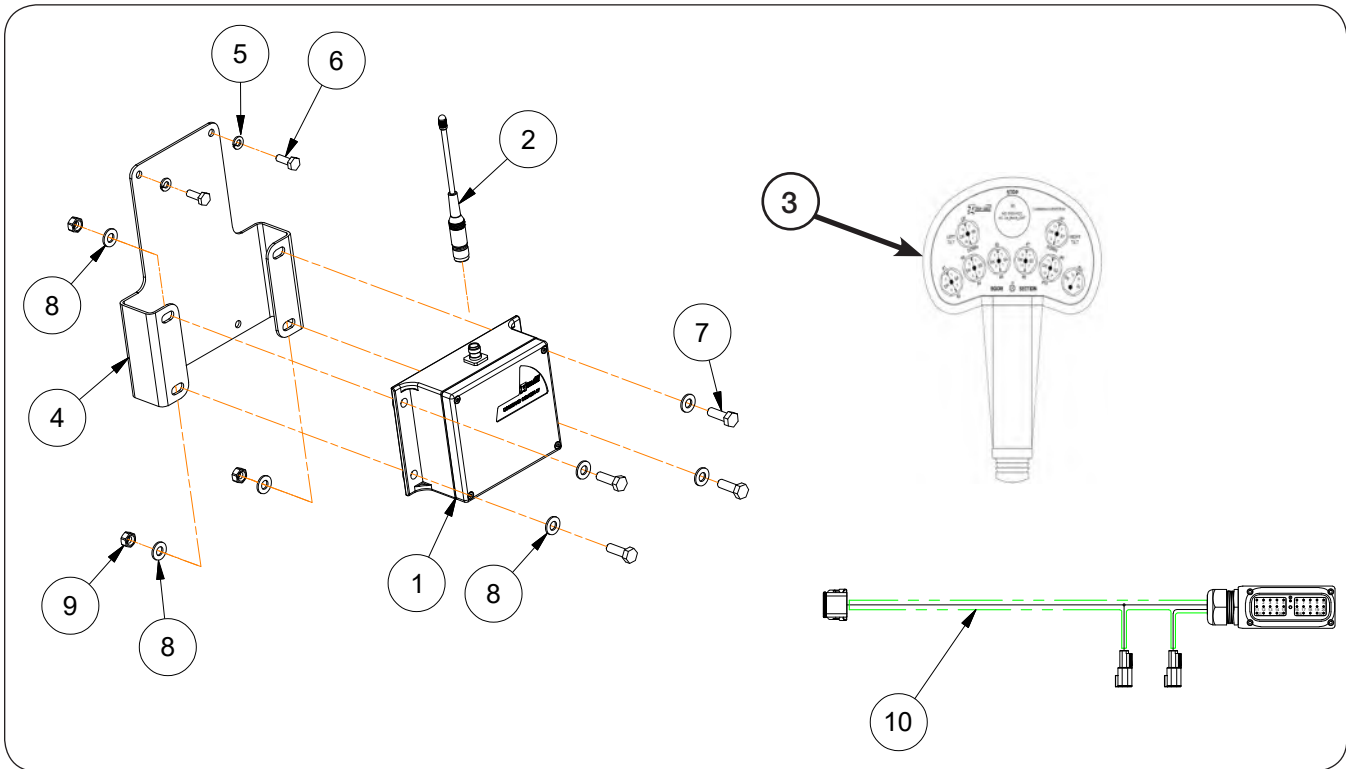

ITEM	PART NO.	DESCRIPTION	QTY.	NOTES
1	9007720	Receiver	1	
2	9007721	Antenna 9/16" Dia. x 6"	1	
3	9007777	Transmitter - Boom Valves & Tilt	1	
4	411910B	Receiver Plate-Bracket =Black=	1	
5	9404-017	Lock Washer 1/4"	4	
6	9390-003	Capscrew 1/4"-20UNC x 3/4"	6	
7	9390-030	Capscrew 5/16"-18UNC x 1"	4	
8	9405-068	Flat Washer 5/16" SAE	8	
9	9398-010	Elastic Locknut 5/16"-18UNC	4	
10	9007775	Receiver Harness 96"	1	

Notes

Please visit www.unverferth.com/parts/ for the most current parts listing.

GEN 1 ISO Rate Control (RCM) Components

Please visit www.unverferth.com/parts/ for the most current parts listing.

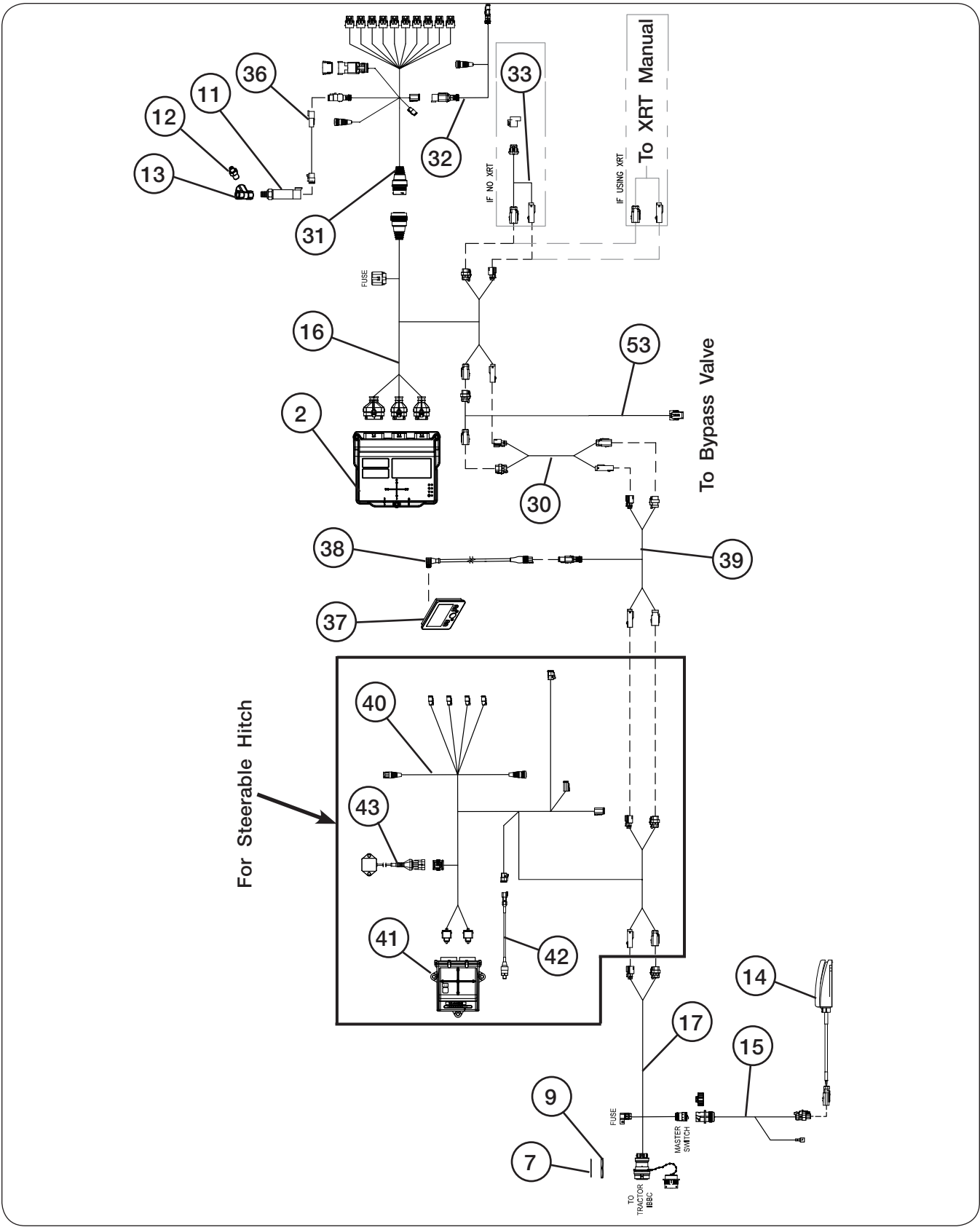

GEN 1 ISO Rate Control (RCM) Components

Please visit www.unverferth.com/parts/ for the most current parts listing.

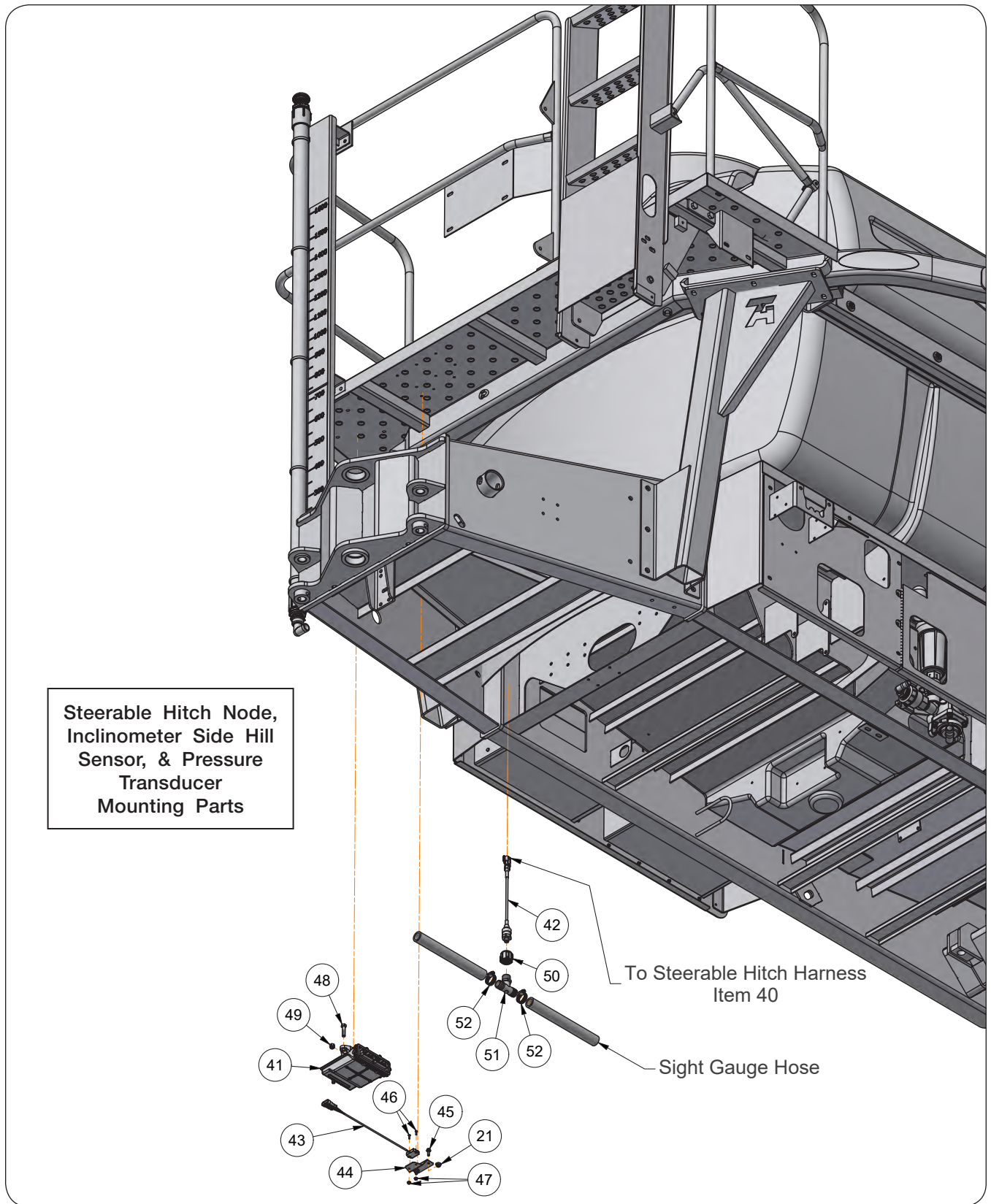

(Continued on next page)

GEN 1 ISO Rate Control (RCM) Components

Please visit www.unverferth.com/parts/ for the most current parts listing.

Switch Box Mounting Parts

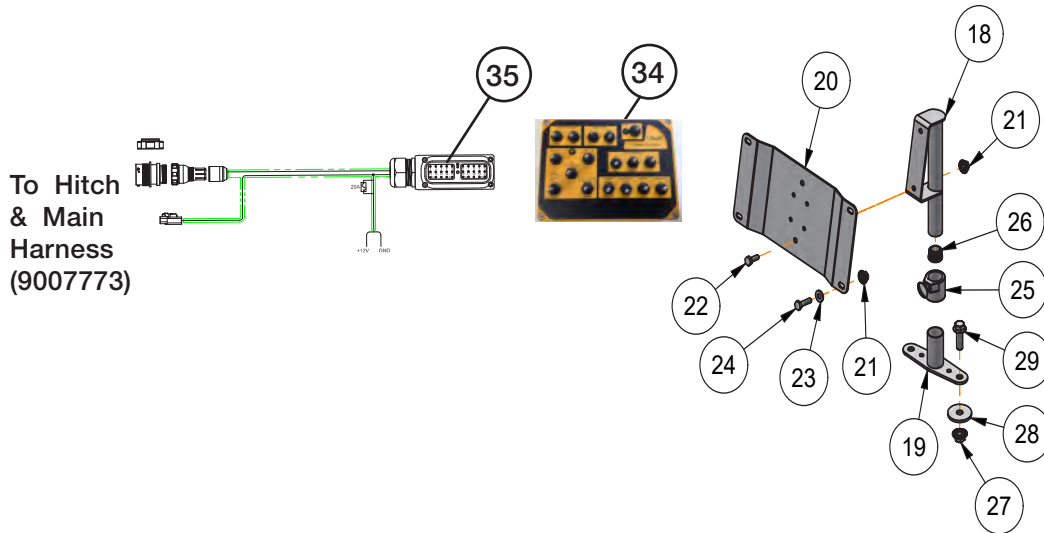

Rate Control Module Node Mounting Parts

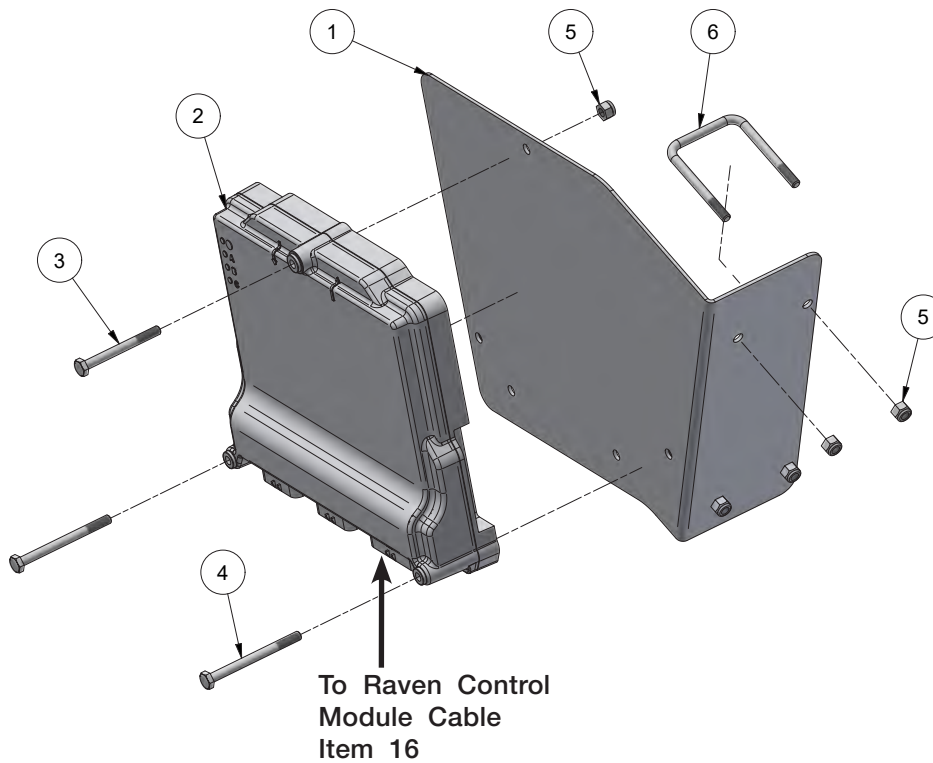

Sprayer TA1200 / TA1600 / TA2400 — Parts

GEN 1 ISO Rate Control (RCM) Components

Please visit www.unverferth.com/parts/ for the most current parts listing.

ITEM	PART NO.	DESCRIPTION	QTY.	NOTES
1	416495B	Plate-Node Bracket =Black=	1	
2	9010054	Rate Control Module Node Level 0	1	Non Hawkeye Sprayers
	9009904	Rate Control Module	1	Hawkeye Sprayers
3	900900-011	Capscrew 1/4"-20UNC x 2 1/2" (SS)	1	
4	900900-013	Capscrew 1/4"-20UNC x 3" (SS)	2	
5	900905-007	Lock Nut 1/4"-20UNC	7	
6	9005638	U-Bolt 1/4"-20UNC x 2 3/4"	2	
7	9006886	Connector Lock Washer Size 24	1	
8	416497	Quick Reference Guide Sprayers	1	Not Shown
9	9006885	Panel Nut Size 24	1	
10	9000106	Cable Tie 7 1/2"	12	Not Shown
11	9503299	Pressure Transducer 1-5 VOLT, 0-250 PSI	1	
12	TA809325	1/4" Hex Pipe Nipple	1	
13	TA809190	Tee- 1/4" FPT	1	
14	9005916	Foot Switch, ISO Node W/ Harness	1	
15	9503390	Foot Switch Cable, 23'	1	
16	9008095	Raven Control Module, Cable-Node	1	
17	9008094	Cable-ISO Tractor	1	
18	407802B	Control Box Mount Weldment, 7 5/8" =Black=	1	
19	407805B	Control Box Bracket Weldment, 5" =Black=	1	
20	411911B	Control Box Bracket Plate =Black=	1	
21	97189	Large Flange Hex Nut 1/4"-20UNC	6	
22	9390-003	Capscrew 1/4"-20UNC x 3/4" Gr. 5	2	
23	9405-062	Flat Washer 1/4" SAE	4	
24	9390-005	Capscrew 1/4"-20UNC x 1" Gr. 5	4	
25	9005888	Tube Adjuster	1	
26	9005889	Finishing Plug	1	
27	91263	Large Flange Nut 3/8"-16UNC	2	
28	9005696	Fender Washer 3/8"	2	
29	9003259	Flange Screw 1/4"-20UNC x 1 1/4"	2	
30	9009901	Extension Cable GEN 1 ISO 17 FT.	1	
31	9009902	Product Control Cable 10 Section	1	
32	9009903	Extension Cable Pump / Fill Flowmeter	1	
33	9008096	Cable Adapter, JD GEN 1 ISO To Terminator	1	
34	9007776	Sprayer Switch Box	1	
35	9007774	Switch Box Console Harness	1	
36	9010272	Extension Cable For Pressure Transducer 25 FT.	1	
37	9009914	Raven ISO Tank Fill Display Console, 4 15/16"	1	
38	9009916	Fill Display Cable	1	
39	9009907	Adapter Cable For Tank Fill Monitor 10 FT.	1	
40	9009380	Steerable Hitch Harness GEN 1 ISO Sprayer	1	
41	9006470	Steerable Hitch Node ISO	1	
42	9009382	Steerable Hitch Pressure Transducer 1-5 VOLT, 0-5PSI	1	
43	9010412	Dual Axis Inclinometer Side Hill Sensor Sprayer	1	Replacement Kit #417804B Includes Items 43-47 & Item 21 (97189 - QTY 2)
44	417803B	Tilt Sensor Plate =Black=	1	
45	97420	Flange Screw, 1/4"-20UNC x 3/4" Gr. 5	2	
46	903172-091	Phillips Pan Head Screw, #6-32 x 1/2"	2	
47	9004709	Serrated Flange Hex Nut, 1/4"-20UNC	2	
48	9390-057	Capscrew 3/8"-16UNC x 1 1/2" Gr. 5	3	
49	9398-012	Locknut 3/8"-16UNC	3	
50	407503	Pipe Cap, 3/4"-14 NPT x 1/4"- 18 NPT	1	
51	TA810496	Tee, 3/4"-14 MPT x 1" Hose Barb	1	
52	TA800912	Hose Clamp SAE #16	2	
53	9010214	Recirculation Valve Cable	1	

Hose Bracket

Please visit www.unverferth.com/parts/ for the most current parts listing.

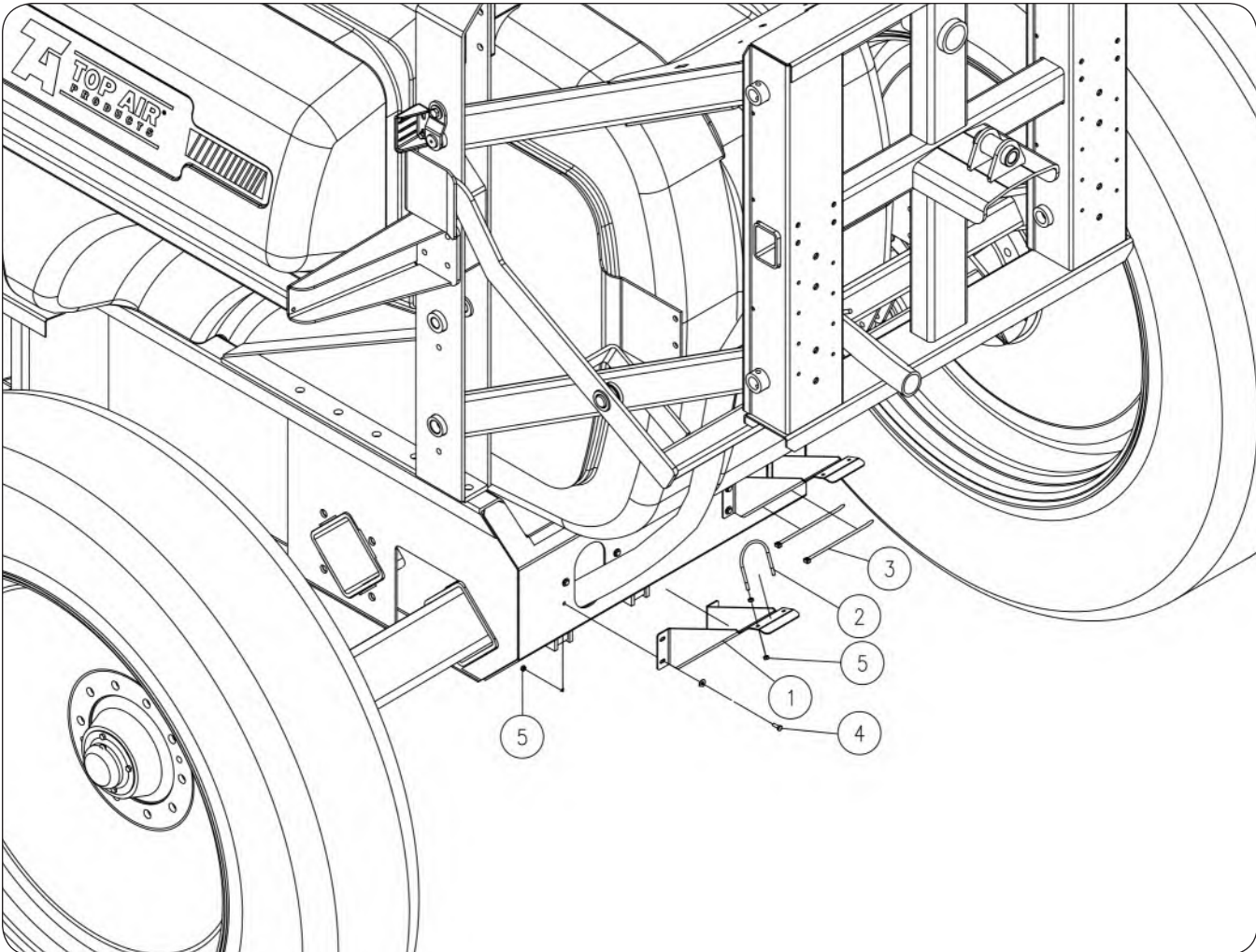

ITEM	PART NO.	DESCRIPTION	QTY.	NOTES
1	403774B	Hose Bracket =Black=	2	
2	9001115	U-Bolt 1/4-20UNC	2	
3	9003735	Cable Tie 11" Long	5	
4	97420	Capscrew, 1/4-20UNC x 3/4 Grade 5	8	
5	97189	Flange Nut, 1/4-20UNC Grade 5	16	

Strainer

Please visit www.unverferth.com/parts/ for the most current parts listing.

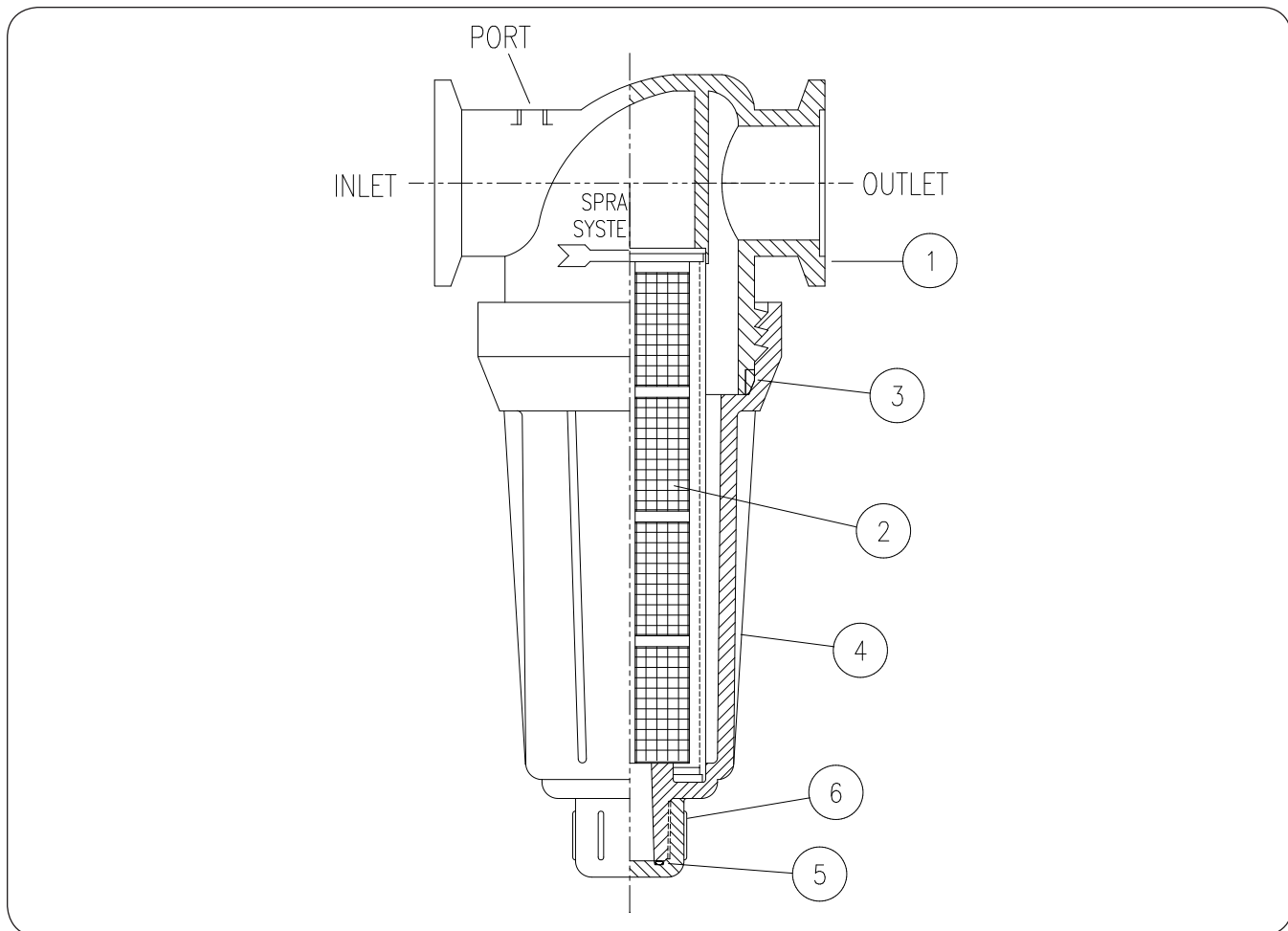

ITEM	PART NO.		DESCRIPTION	QTY.	NOTES
		With Inlet Port			
	9010128	9010129	Strainer Complete	1	2" Flange
1	TA868841	403257	Strainer Head	1	
2	TA869071	>	Screen, 80 Mesh (Polypropylene Frame)	1	
3	TA856055	>	Gasket 3 1/2" I.D., EPDM	1	
4	TA868842	>	Bowl, Polypropylene	1	
5	TA856065	>	Gasket 13/16" I.D., EPDM	1	
6	TA868844	>	Cap, Polypropylene	1	

Main Tank

Please visit www.unverferth.com/parts/ for the most current parts listing.

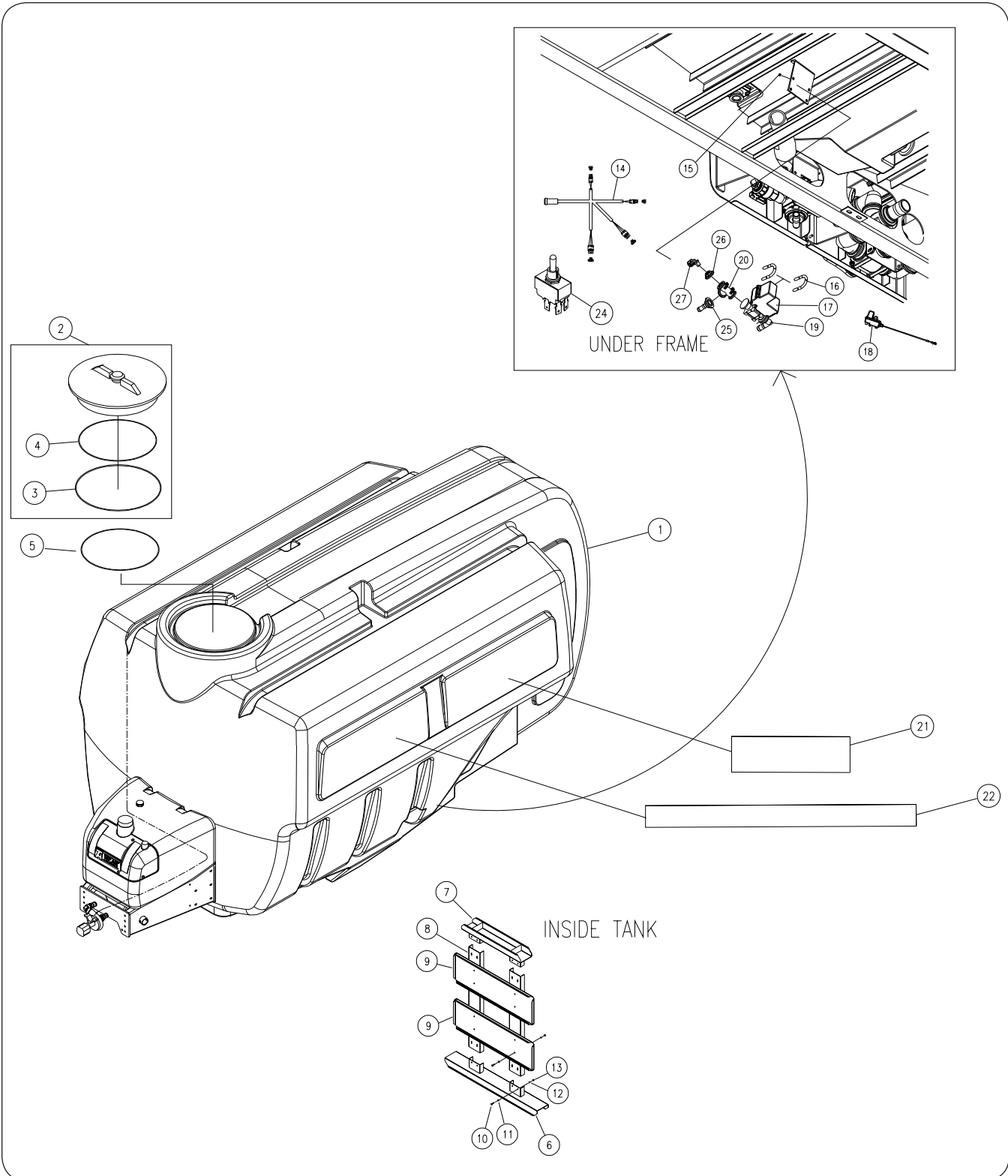

Sprayer TA1200 / TA1600 / TA2400 — Parts

Main Tank

Please visit www.unverferth.com/parts/ for the most current parts listing.

ITEM	PART NO.			DESCRIPTION	QTY.	NOTES
	1200	1600	2400			
1	407371	407372	407375	Tank, =Gray=	1	
2	9008576	>	>	Tank Lid Vented & Hinged 16"	1	Includes Items 3 & 4
3	9010319	>	>	Tank Lid Gasket, 16 1/8" I.D.	1	
4	9010320	>	>	Tank Lid O-Ring, 15 7/8" I.D.	1	
5	TA805198	>	>	O-Ring For 16" Lid	1	
6	401817	>	403739	Lower Baffle Weldment	1	
7	401818	>	>	Upper Baffle Weldment	1	
8	402696	401819	406799	Upright	2	
9	401820	>	>	Baffle Panel	2	
10	900900-054	>	>	Capscrew, 3/8-16UNC x 7/8 SS	16	
11	900902-044	>	>	Flat Washer, 1/2 SS	16	
12	9004497	>	>	Fender Washer, 3/8 SS	32	
13	900906-006	>	>	Locknut, 5/16-18UNC SS	16	
14	9004550	>	>	Harness, Valve	1	
15	9807	>	>	Locknut, 5/16-18UNC	4	
16	100965	>	>	U-Bolt, 5/16-18UNC x 2.18 x 1.6cc G5	2	
17	9003957	>	>	Electric Ball Valve	1	
18	TA854876	>	>	Replacement Motor Valve	1	
19	TA815018	>	>	Elbow, 1" Flange x 1" HB	1	
20	TA815005	>	>	Tee Fitting 1" Flange x 1" Flange	1	
21	9009056	>	9009086	Decal, Top Air Tank Logo	2	
22	9009081	9009082	9009084	Decal, Top Air Right-Side	1	
	9009062	9009083	9009085	Decal, Top Air Left-Side	1	
23	9009057	>	-	Decal, Top Air Stripe	2	Not Shown
24	9004564	>	>	Momentary Switch	1	
25	TA815013	>	>	Hose Barb 1" Flange x 3/4" HS	1	Poly Pipe Plug
26	9504009	>	>	Manifold Plug	1	
27	TA720802	>	>	Elbow 1/4" NPT x 1/4" Gauge Tube	1	Poly Reducer
28	TA805192	>	>	Tank Repair Kit - Poly	1	Not Shown
29	TA805160	>	>	Welding Rod - Poly	1	Not Shown

(Continued on next page)

Main Tank Plumbing

Please visit www.unverferth.com/parts/ for the most current parts listing.

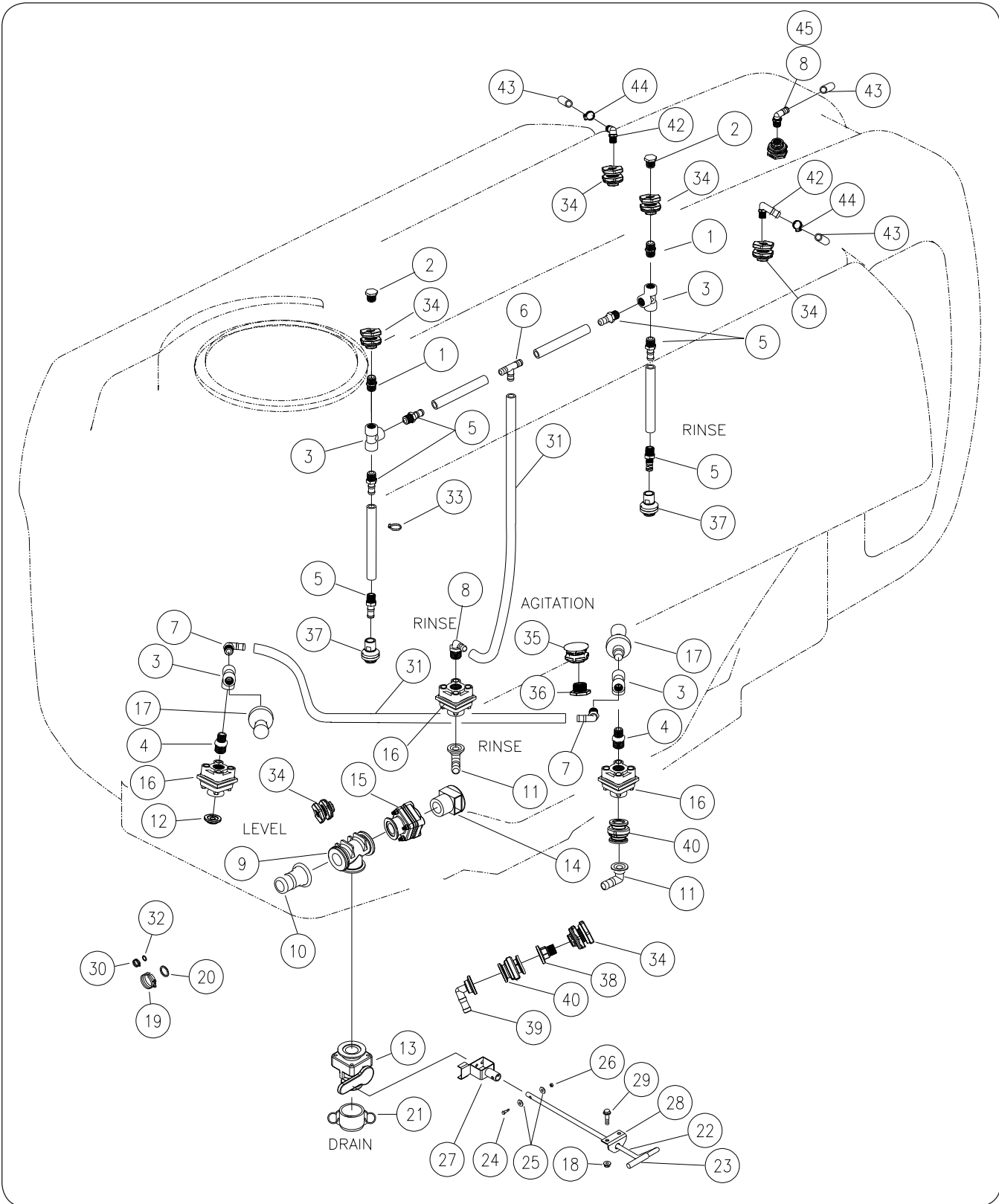

Sprayer TA1200 / TA1600 / TA2400 — Parts

Main Tank Plumbing

Please visit www.unverferth.com/parts/ for the most current parts listing.

ITEM	PART NO.			DESCRIPTION	QTY.	NOTES
	1200	1600	2400			
1	TA814605	>	>	Nipple, Short Poly - 3/4"	2	
2	TA814751	>	>	Plug, MPT 3/4	2	Poly Pipe Plug
3	TA814781	>	>	Tee, Poly Pipe - 3/4"	4	
4	TA814815	>	>	Reducer Nipple, 1 x 3/4	2	Poly Reducer
5	TA814861	>	>	Hose Barb, 3/4 x 3/4 MPT	6	
6	TA814891	>	>	Tee, 3/4" Hose Barb	1	
7	TA814961	>	>	Elbow, 3/4 MPT x 3/4 HB	2	
8	TA814965	>	-	Elbow, 1 MPT x 3/4 HB 90°	2	1200 Sprayers & 80'-100' Boom Sprayers
9	TA815007	>	>	Tee, 2" Std. Flange	1	Manifold Tee
10	TA815016	>	>	Flange Hose Barb, 2" Fl. X 2" HB	1	Straight
11	TA815018	>	>	Flange Hose Barb, 1" Fl. X 1" HB 90°	1	
12	TA815022	>	>	Flange Plug, 1"	1	
13	TA815047	>	>	Valve, 2" Fl. x 2" QDC	1	
14	TA815074	>	>	Vent Cap, 2"	1	
15	TA815076	>	>	Tank Fitting, 2" Flange	1	
16	TA815077	>	>	Tank Fitting, 1" Flange	3	
17	TA816012	>	>	Agitation Fitting	2	
18	91263	>	>	Large Flange Nut, 3/8-16UNC GR. 5	1	
19	TA815025	>	>	Flange Clamp, 2"	A/R	
20	TA811944	>	>	EPDM Gasket, 2"	A/R	
21	TA811500	>	>	Cap Coupler Poly 2"	1	
22	402634B	>	>	Handle, Dump Valve =Black=	1	
23	9004015	>	>	Grip, Yellow	1	
24	9390-008	>	>	Capscrew, 1/4-20UNC x 1 3/4	1	
25	9405-064	>	>	Flat Washer, 1/4	2	
26	9936	>	>	Locknut, 1/4-20UNC	1	
27	402611B	>	>	Handle Weldment =Black=	1	
28	402635B	>	>	Bracket =Black=	1	
29	95585	>	>	Large Flange Bolt, 3/8-16UNC x 3/4	1	
30	TA815026	>	>	Flange Clamp, 1"	A/R	
31	TA806250	>	>	Hose, 3/4" EPDM	A/R	Specify In Feet
32	TA815029	>	>	EPDM Gasket, 1"	A/R	
33	TA800912	>	>	Hose Clamp, Stainless Steel	10	
34	TA805408	>	>	Tank Manifold Fitting, 3/4" Double Threaded	6	
35	TA805424	>	>	Tank Fitting 1 1/2" Anti-Vortex	1	2 3/4" Hole Required
36	TA810015	>	>	Hex Plug 1 1/2"	1	
37	9005451	>	>	Rinse Nozzle 3/4-14NPT Female	2	
38	TA816021	>	>	Adapter, 1"M Flange x 3/4"M MPT	1	
39	TA815017	>	>	Hose Barb 90° Elbow, 1" Flange x 3/4"	1	
40	9006665	>	>	Check Valve - 1" Flange	2	
41	TA805412	>	>	Tank Fitting 1"	1	2 1/4" Hole Required
42	TA814963	>	>	Elbow, 90 Degree 3/4"-14NPTF x 1" Hose	2	
43	TA806275	>	>	Hose, 1" EPDM	A/R	Specify In Feet
44	TA800912	>	>	Hose Clamp, 13/16" To 1 1/2" Dia. SS	2	
45	-	TA814966	>	Elbow, 1 MPT x 1 HB 90°	1	120'-132' Boom Sprayers For Flowback Routing

Front Plumbing Components - Models 1200 / 1600 / 2400

Please visit www.unverferth.com/parts/ for the most current parts listing.

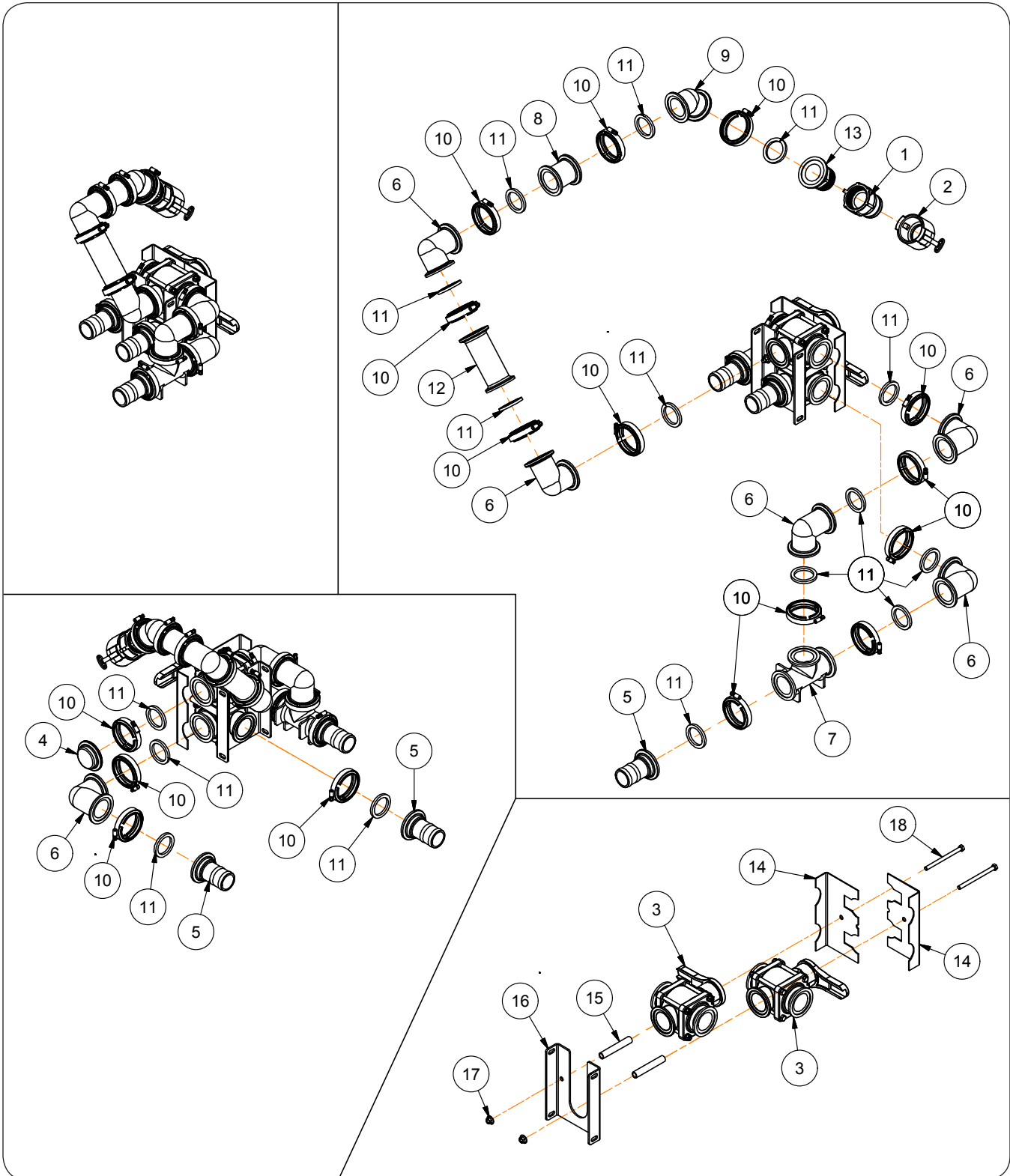

Front Plumbing Components - Models 1200 / 1600 / 2400

Please visit www.unverferth.com/parts/ for the most current parts listing.

ITEM	PART NO.	DESCRIPTION	QTY.	NOTES
1	TA810625	Quick Disconnect Coupling 2" Male Adapter x 2-11 1/2 NPTF Female	1	
2	TA811500	Cap Coupler Poly 2"	1	
3	TA816020	3-Way Ball Valve, 2" Full Port w/ Handle	2	
4	TA816013	Plug, 2" Full Port Flange	1	
5	TA816008	Straight 2" Full Port Flange x 2" HB	3	
6	TA816010	Elbow, 2" Full Port Flange	6	
7	TA816011	Tee, 2" Full Port Flange x 2" Full Port Flange x 2" Full Port Flange	1	
8	TA816014	Coupler, 2" Full Port Flange	1	
9	TA816015	45° Elbow 2" Full Port Flange x 2" Full Port Flange	1	
10	TA816000	Clamp, 2" Full Port Flange	16	
11	TA816001	Gasket, 2" Full Port Flange	16	
12	TA816055	Coupler 2" Full Port 6" Long	1	
13	TA816016	Adapter 2" Flange Male x 2" NPT Male	1	
14	403870B	Bracket Valve =Black=	2	
15	403858B	Bushing-Spacer =Black=	2	
16	403874B	Bracket-Valve =Black=	1	
17	91263	Large Flange Nut 3/8-16UNC	2	
18	9390-069	Capscrew 3/8-16UNC x 5 Grade 5	2	

Rear Plumbing Components - Models 1200 / 1600 / 2400

Please visit www.unverferth.com/parts/ for the most current parts listing.

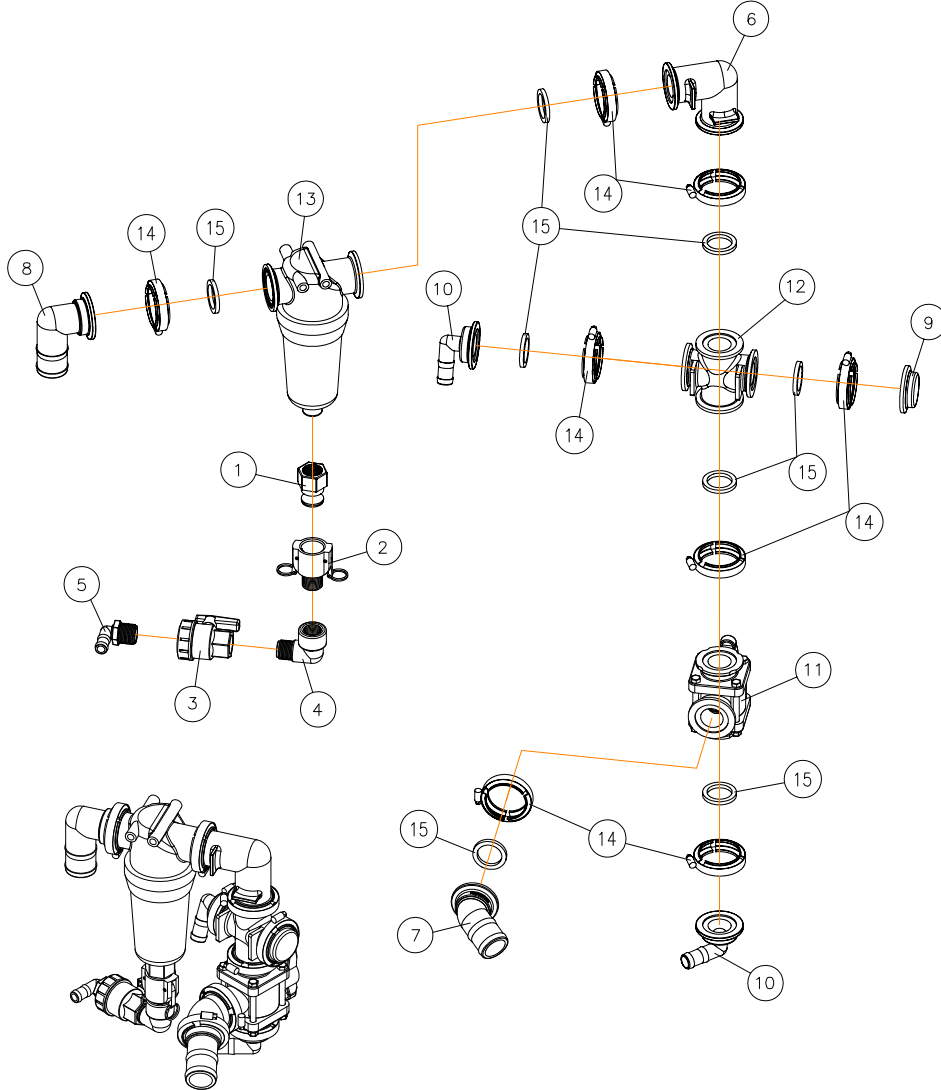

Rear Plumbing Components - Models 1200 / 1600 / 2400

Please visit www.unverferth.com/parts/ for the most current parts listing.

ITEM	PART NO.	DESCRIPTION	QTY.	NOTES
1	TA810550	Coupler, 1" Quick	1	
2	TA810675	Coupler, 1" Female Quick	1	
3	TA811517	Ball Valve, 1" Union	1	
4	TA814692	Elbow, 1" Street	1	
5	TA814965	Elbow, 1 NPT x 3/4 HB 90°	1	
6	TA815004	Elbow, 2" STD Flange	1	
7	9005587	Adapter, 2" Flange x 2" HB	1	
8	TA815021	Adapter, 2" STD Flange x 2" HB 90°	1	
9	TA815023	2" STD Flange Plug	1	
10	TA815024	2" Flange x 1" HB 90° Elbow	2	
11	TA815048	2" 3-Way Ball Valve	1	
12	TA816019	Cross, 2" 4-Way	1	
13	9010128	2" Flange Strainer Complete, 80 Mesh	1	
14	TA815025	Clamp, 2" Flange	8	
15	TA811944	Gasket, 2" Flange	8	

Plumbing Overhead Layout - Models 1200 / 1600 / 2400

Please visit www.unverferth.com/parts/ for the most current parts listing.

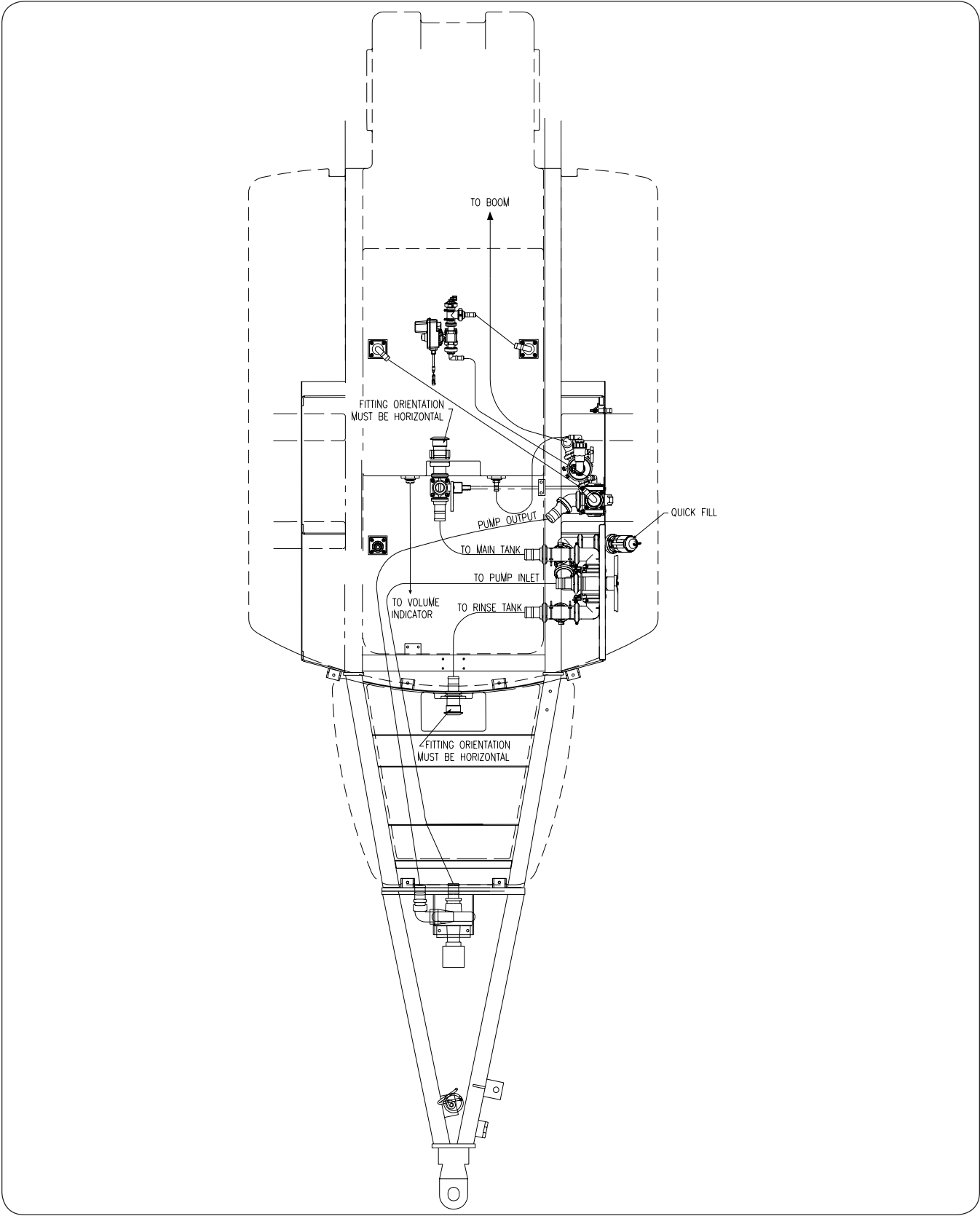

Hydraulic Valve Conversions

Please visit www.unverferth.com/parts/ for the most current parts listing.

CLOSED CENTER CONVERSION

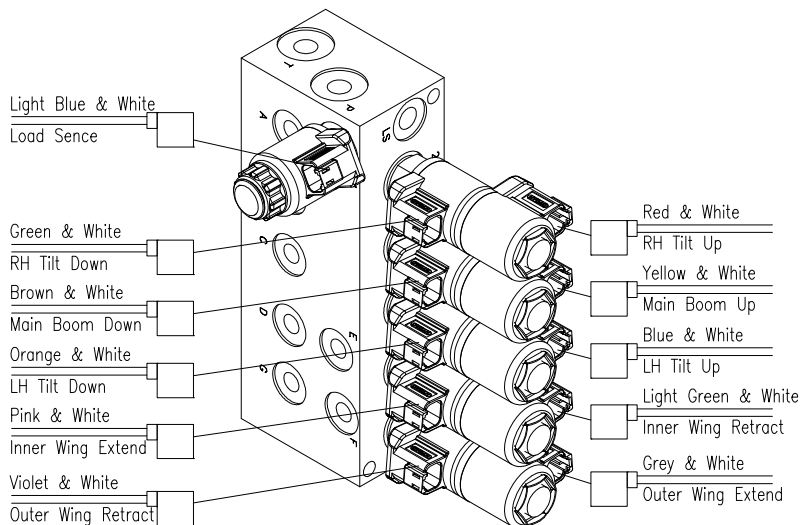
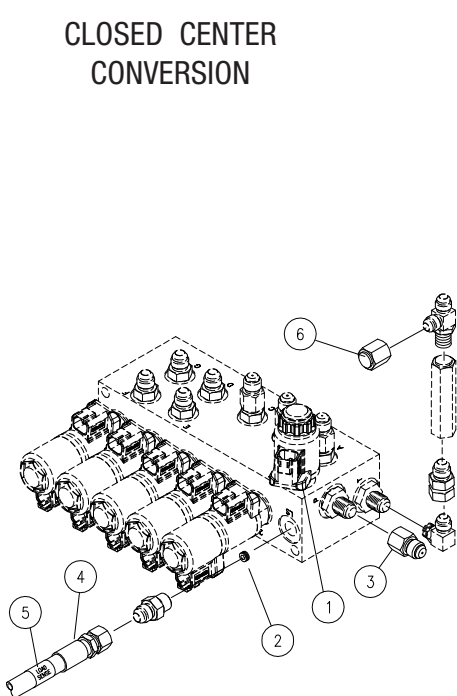

CLOSED CENTER CONVERSION (For Power Beyond Load Sense Tractors)			
ITEM	PART NO.	DESCRIPTION	QTY.
	402406	1600 Kit Includes:	1
1	9003852	Cartridge, Closed Center	1
2	9003933	Orifice (Closed Center)	1
3	9002199	Restrictor Reducer, .062"	1
4	9003948	Hose, 1/4 x 3/2"	1
5	9003940	Hose Marker	1
6	9001850	Cap	1

PRESSURE COMPENSATING CLOSED CENTER CONVERSION

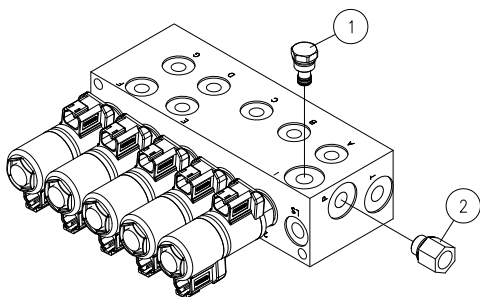

PRESSURE COMPENSATING CLOSED CENTER CONVERSION			
ITEM	PART NO.	DESCRIPTION	QTY.
	406107	Kit Includes:	1
1	9006486	Cavity Plug	1
2	9006531	Port Reducer O-Ring Orifice	1

Hydraulic Valve

Please visit www.unverferth.com/parts/ for the most current parts listing.

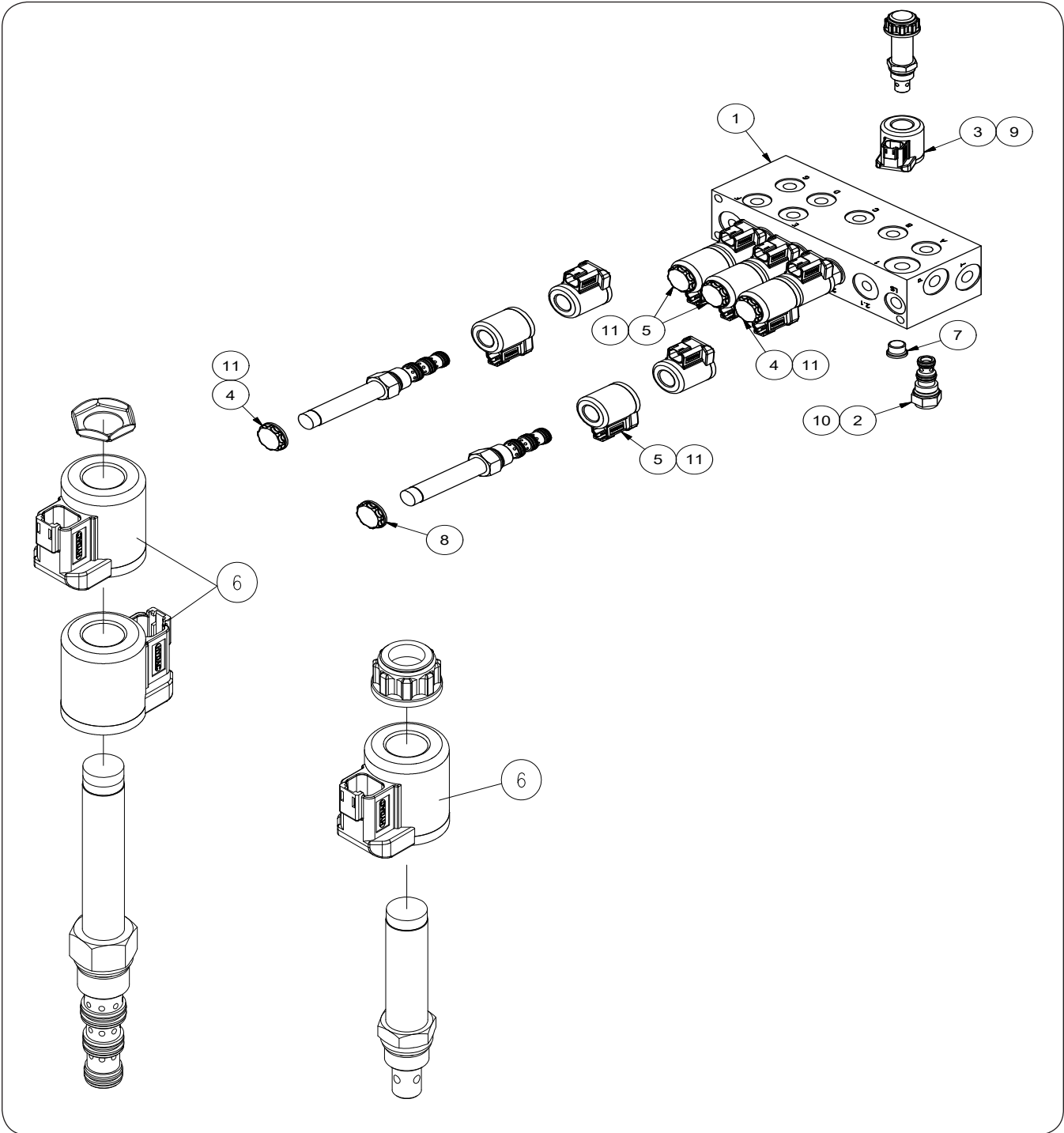

Hydraulic Valve

Please visit www.unverferth.com/parts/ for the most current parts listing.

ITEM	PART NO.	DESCRIPTION	QTY.	NOTES
	9006399	Hydraulic Valve Complete	1	
1	9003851	Manifold Block, Aluminum	1	
2	9003856	Check Valve, Pilot Operated	6	
3	9003857	Cartridge, 2-Position (Open Center)	1	Load Sense / Unloader
4	9003854	Cartridge Valve, 3-Position	2	Boom Lift, Outer Wing Fold
5	9003855	Cartridge Valve, 3-Position (Special)	3	RH / LH Tilt, Main Wing Fold
6	9005769	Coil, 12 Volt DC	11	
7	9003423	Hollow Hex Head Plug	1	Standard
8	9004760	Coil Nut w/O-Ring Groove	-	
Seal Kits				
9	9003904	Seal Kit, For 2 Pos, Cartridge	1	Item 3
10	9003905	Seal Kit, For Check Valve	1	Item 2
11	9003906	Seal Kit, For 3-Pos, Cartridge	1	Item 4 & 5

Inductor Plumbing - Optional

Please visit www.unverferth.com/parts/ for the most current parts listing.

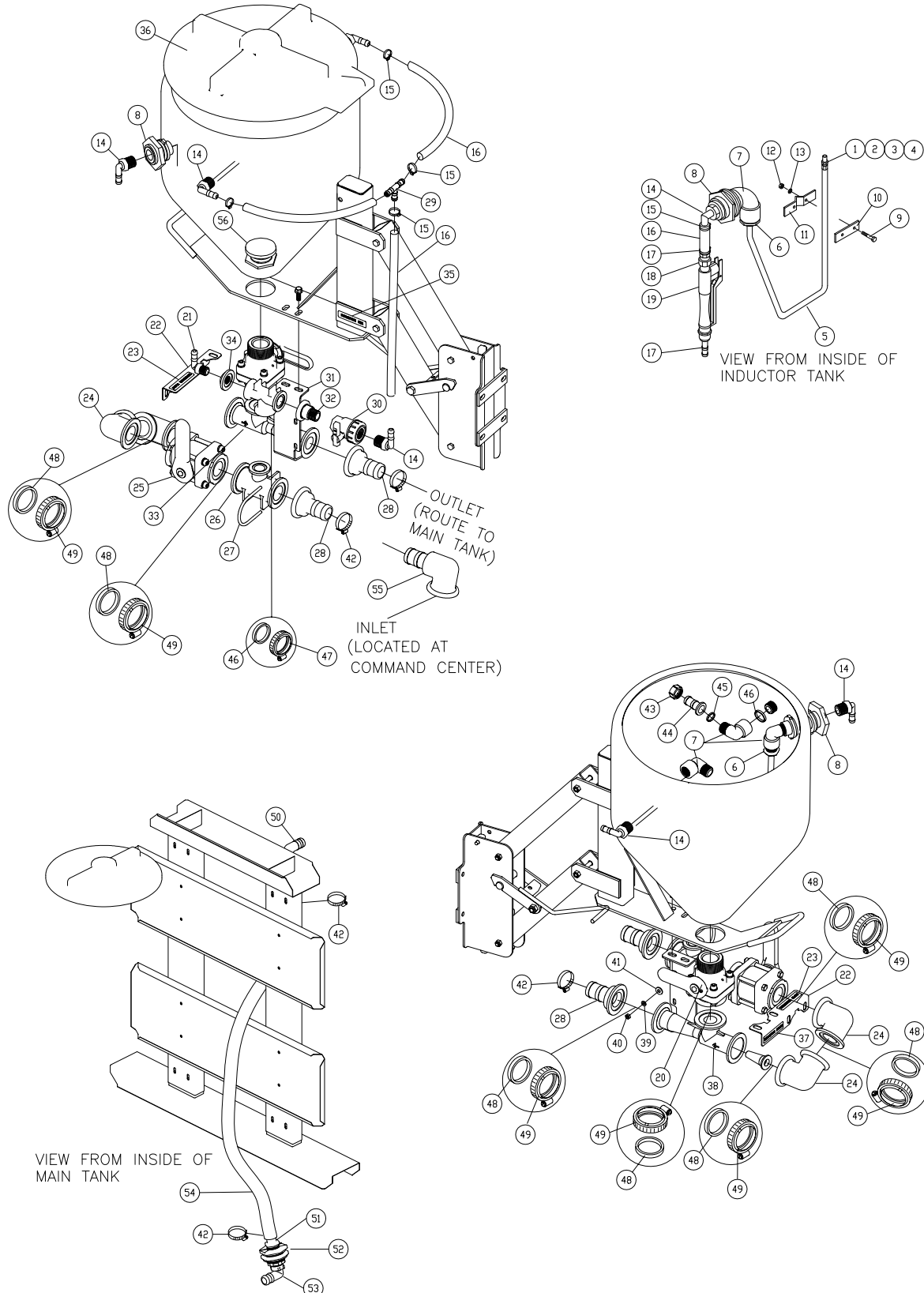

Inductor Plumbing - Optional

Please visit www.unverferth.com/parts/ for the most current parts listing.

ITEM	PART NO.	DESCRIPTION	QTY.	NOTES
1	TA848450	Full Jet Celcon Tip - FL15	1	
2	TA865240	Mesh Strainer (8079-PP-50-NY)	1	
3	TA865180	T-Jet Cap (8027-NY)	1	
4	TA867250	T-Jet Cap, Extra Long (8027-1-NY)	1	
5	TA1-114776-0	Tube, Inductor Bottle Washer	1	
6	TA814651	Reducer Bushing, 3/4 x 1/4" Poly	1	
7	TA814691	Street Elbow, 3/4" Poly	1	
8	TA805408	Fitting, 3/4" Double Thread	1	
9	TA0-907048-0	Capscrew, 5/16-18NC x 1 SS	2	
10	TA1-114778-0	Support, Bottle Washer	1	
11	TA1-114777-0	Clamp, Bottle Washer	1	
12	TA0-907826-0	Nut, 5/16-18NC SS	2	
13	TA0-908480-0	Lock Washer, 5/16 SS	2	
14	TA814960	Elbow, 90° - 3/4" MPT x 1/2 Hose	1	
15	TA800902	Hose Clamp, M-6 SS	2	
16	TA806225	Hose, 1/2" EPDM	AR	Specify Length In Feet
17	TA810100	Hose Barb, 1/4" MPT x 1/2" Straight	1	
18	TA861885	T-Jet Adapter, 4676-NY-1/4	1	
19	TA885299	Spray Gun (22650-PP-1/4)	1	
20	TA816022	Valve, 2" Flg x 2" MPT	1	
21	TA814956	Elbow, 1/2 Poly x 1/2 NPTF	1	
22	402872B	Bracket, Ind. Valve	1	
23	9004320	Decal, Inductor Flow	1	
24	TA816017	Elbow, 2" Flg - Short	2	
25	TA815045	2" Ball Valve	1	
26	TA815006	2" Flg. x 1" Flg Tee	1	
27	9001114	U-Bolt, 1/4-20UNC x 3 1/2	1	
28	TA815015	2" Flg x 1 1/2" HB	2	
29	TA808725	1/2" HB Tee	1	
30	TA811515	Banjo, 3/4" Ny-Glass Ball Valve	1	
31	402651B	Plate, Inductor	1	
32	TA816021	Adapter, 1" Flg x 1/2 FPT	1	
33	TA815005	1" Flg Tee	1	
34	TA816023	Plug, 1" Flg x 1/2 FPT	1	
35	9004322	Decal, Inductor Mix	1	

(Continued on next page)

Inductor Plumbing - Optional (continued)

Please visit www.unverferth.com/parts/ for the most current parts listing.

ITEM	PART NO.	DESCRIPTION	QTY.	NOTES
36	TA805210	Solution Tank Lid	1	
37	9004321	Decal, Inductor Drain	1	
38	TA816018	Flanged Venturi, 2"	1	
39	9404-014	Lock Washer, 1/4"	2	
40	9394-002	Nut, 1/4-20UNC Gr. 5	2	
41	9405-064	Flat Washer, 1/4"	2	
42	TA800916	Hose Clamp, Stainless Stl.	7	
43	TA809160	3/4" Hex Nut	2	
44	TA809754	Hose Barb, 1/2" Flat Seat	2	
45	TA809746	Poly Washer	2	
46	TA815029	Gasket, Seal	5	
47	TA815029	Clamp, 1" Flange	3	
48	TA811944	Gasket, Seal	8	
49	TA815025	Clamp, 2" Flange	8	
50	TA808518	Elbow, 1 1/2" Hose Barb	1	
51	TA814875	Adapter, 1 1/2" HB x 1 1/2" NPTF-Male	1	
52	TA805422	Double Threaded Fitting, 1 1/2"	1	
53	TA814975	Elbow, 1 1/2"HB x 1 1/2" Male NPT	1	
54	TA806325	Hose, 1 1/2" EPDM	AR	Specify Length In Feet
55	TA815020	Elbow, 2" Flange x 1 1/2" HB	1	Command Center Hook-Up
56	9005306	Anti-Vortex Fitting 2"	1	

Notes

A large, empty rectangular area with rounded corners, intended for handwritten notes. The area is currently blank.

Inductor Mounting - Optional

Please visit www.unverferth.com/parts/ for the most current parts listing.

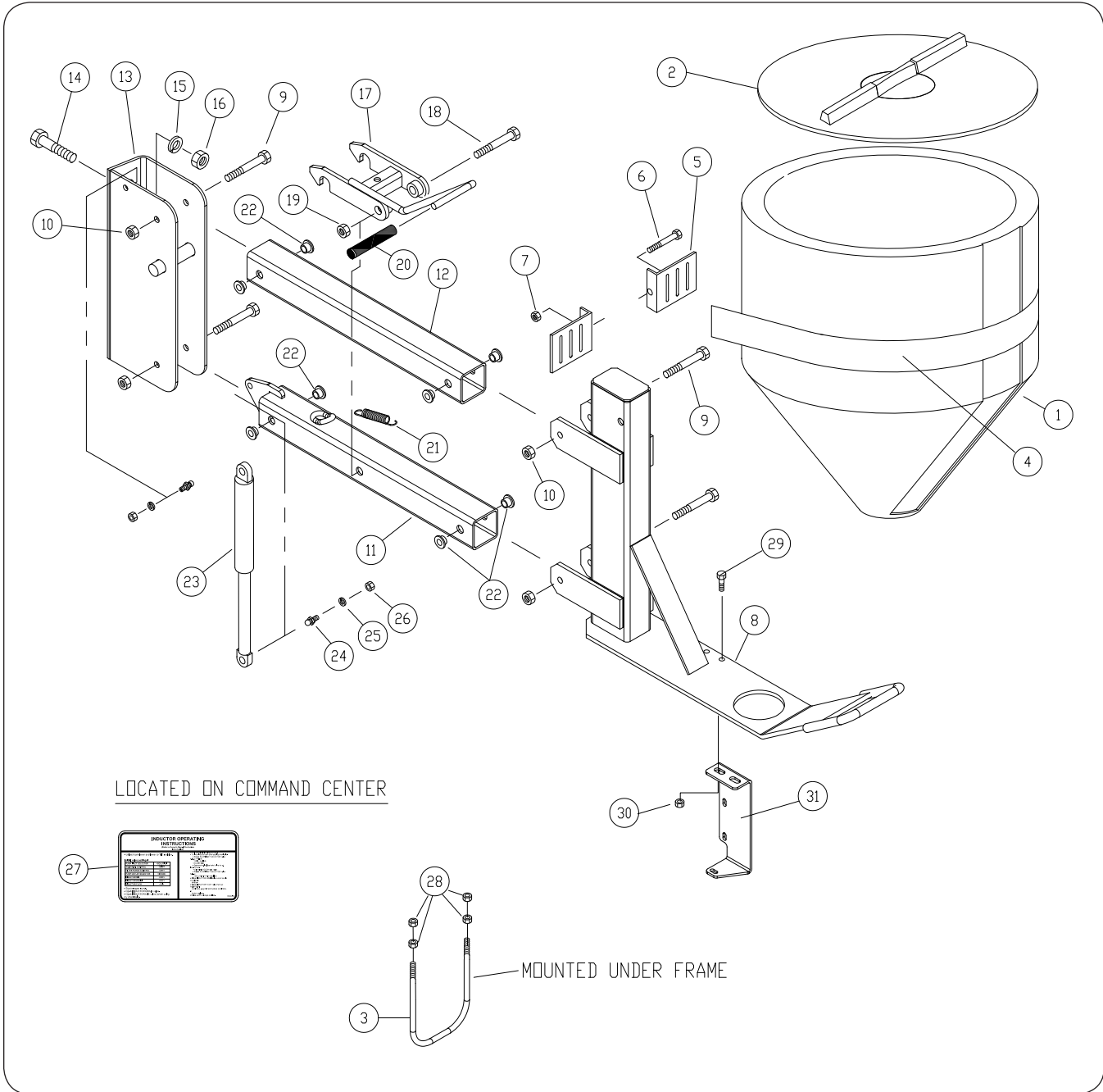

Inductor Mounting - Optional

Please visit www.unverferth.com/parts/ for the most current parts listing.

ITEM	PART NO.	DESCRIPTION	QTY.	NOTES
1	407469	15-Gallon Tank With Lid (Gray)	1	Includes Item 2
2	TA805210	Lid, 16" - Complete	1	
3	9004014	U-Bolt	1	
4	TA500499	Tank Strap	5.5 Ft	Specify In Feet
5	TA510025	Clip, Tank Strap	2	
6	9390-063	Capscrew, 3/8-16UNC x 3	1	Grade 5
7	9928	Lock Nut, 3/8-16UNC	1	Grade 5
8	407096B	Inductor Support Weldment =Black=	1	
9	9390-064	Capscrew, 3/8-16UNC x 3 1/4	4	Grade 5
10	9928	Locknut, 3/8-16UNC	4	Grade 5
11	400684B	Lower Lift Arm Weldment =Black=	1	
12	400666B	Upper Lift Tube =Black=	1	
13	400686B	Inductor Mount =Black=	1	
14	9390-099	Capscrew, 1/2-13UNC x 1	2	Grade 5
15	9404-025	Lock Washer, 1/2	2	
16	9394-010	Hex Nut, 1/2-13UNC	2	Grade 5
17	400717B	Lock Weldment =Black=	1	
18	9390-111	Capscrew, 1/2-13UNC x 4	1	Grade 5
19	94981	Locknut, 1/2-13UNC	1	
20	9003869	Grip	1	
21	9000725B	Spring =Black=	1	
22	9003862	Shoulder Washer, 3/8" ID	8	
23	9003684	Gas Spring	1	
24	9003832	Ball Stud	2	
25	9404-019	Lock Washer, 5/16	2	
26	9394-004	Hex Nut, 5/16-18UNC	2	Grade 5
27	9004324	Decal, Inductor Operating Instructions	1	
28	9394-002	Hex Nut, 1/4-20UNC	4	Grade 5
29	91262	Large Flange Screw, 3/8-16UNC x 1	2	Grade 5
30	91263	Nut, Large Flange 3/8-16UNC	1	Grade 5
31	402651B	Plate, Inductor =Black=	1	

Rinse Tank

Please visit www.unverferth.com/parts/ for the most current parts listing.

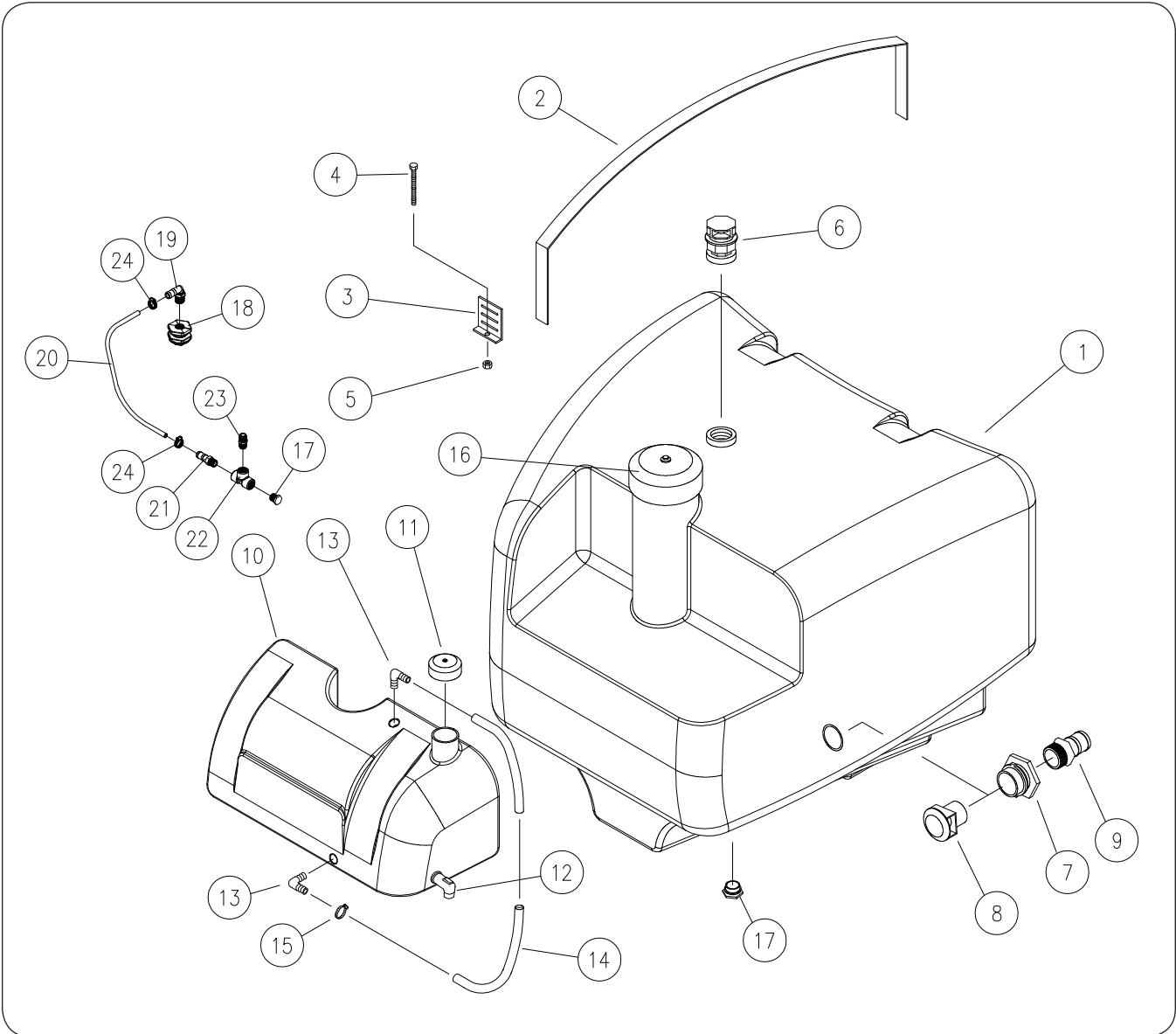

Rinse Tank

Please visit www.unverferth.com/parts/ for the most current parts listing.

ITEM	PART NO.			DESCRIPTION	QTY.	NOTES
	1200	1600	2400			
1	407373	-	-	Rinse Tank, 140 Gallon =Gray=	1	
	-	407374	>	Rinse Tank, 165 Gallon =Gray=	1	
2	TA500499	>	>	Nylon Strap, 2"	A/R	Specify In Feet
3	TA510025	>	>	Clip, Strap	2	
4	TA0-907131-0	>	>	Capscrew, 3/8-16UNC x 4 1/2	2	Grade 5 - Full Threaded
5	9398-012	>	>	Elastic Locknut, 3/8-16UNC	2	Grade 5
6	TA816056	>	>	1" Antivortex Fitting, Tank Vent	1	
7	TA805428	>	>	Tank Fitting, 2"	1	
8	TA815074	>	>	Vent Cap	1	
9	TA814880	>	>	Hose Barb, 2" x 2" MPT	1	
10	406067	>	>	Clean Water Tank =Gray=	1	USE 406356
11	TA510074	>	>	Cap - Vented	1	
12	TA510073	>	>	KBI Fitting (Spigot)	1	
13	TA808275	>	>	Elbow, 3/4 MPT x 1/2 HB 90°	2	
14	TA806554	>	>	Clear Vinyl Hose, 1/2" Dia.	A/R	Specify In Feet
15	TA801065	>	>	Hose Clamp, 1/4" x 3/8"	1	
16	TA805503	>	>	Tank Lid - 5"	1	
17	TA814750	>	>	Plug, 1/2"-14 NPTF	2	
18	TA805408	>	>	Manifold Fitting, 3/4"	1	
19	TA814961	>	>	90° Hose Barb Elbow, 3/4 x 3/4-14NPT Male Poly	1	
20	TA806558	>	>	Clear Vinyl Tubing, 3/4" Dia.	A/R	Specify In Feet
21	TA814857	>	>	Straight Poly Hose Barb, 1/2-14MPT x 3/4 HS	1	
22	TA814780	>	>	Tee, 1/2" Female Poly	1	
23	TA814600	>	>	Nipple 1/2" x Close Poly	1	
24	TA800910	>	>	Hose Clamp	2	

Sight Gauge

Please visit www.unverferth.com/parts/ for the most current parts listing.

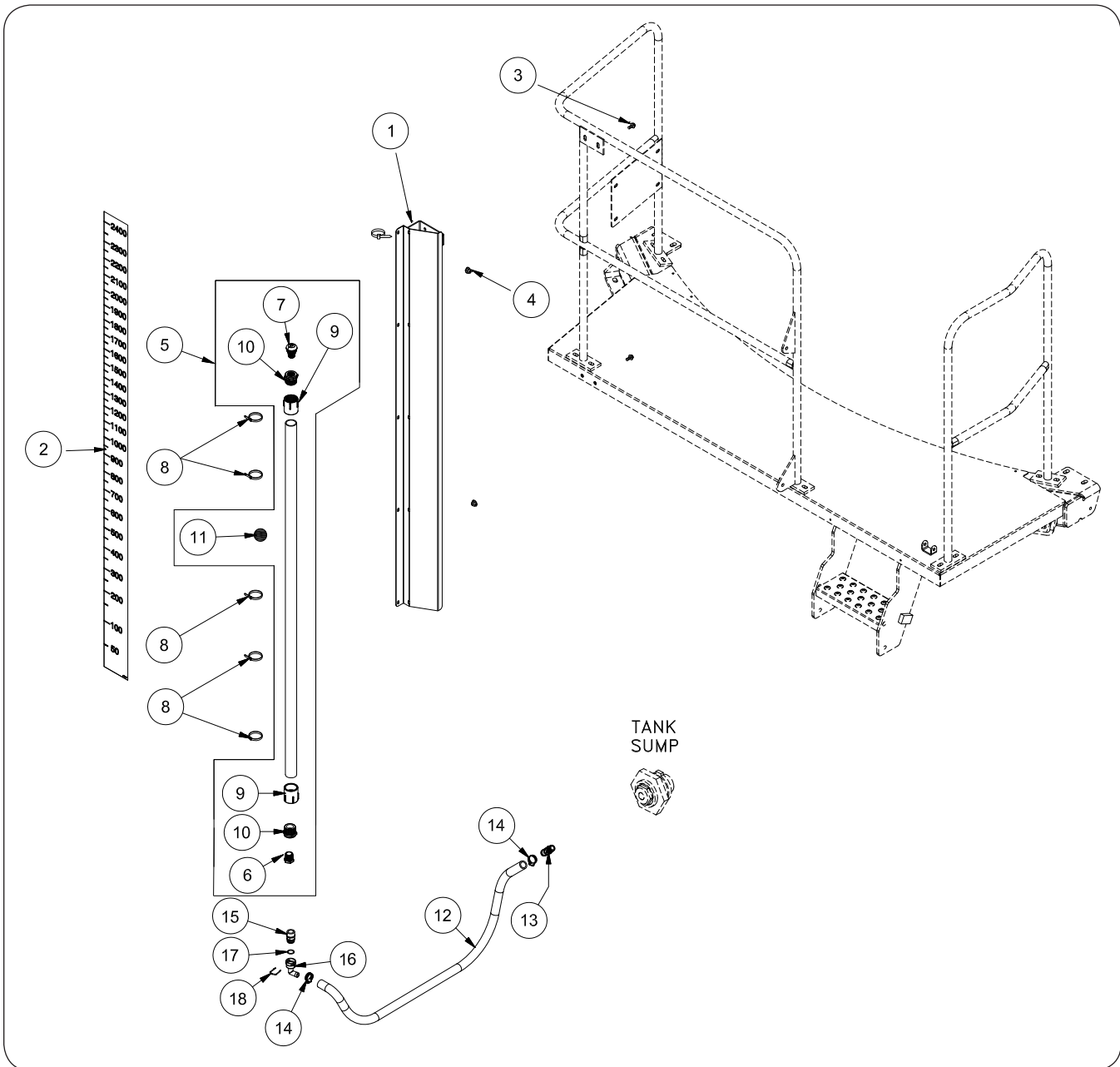

Sight Gauge

Please visit www.unverferth.com/parts/ for the most current parts listing.

ITEM	PART NO.			DESCRIPTION	QTY.	NOTES
	1200	1600	2400			
1	402806B	400745B	405703B	Sight Gauge Weldment =Black=	1	
2	9004817	9004834	9004852	Decal, "Volume Indicator" (Gray)	1	
3	95585	>	>	Capscrew Large Flange, 3/8-16 x 3/4	4	Grade 5
4	91263	>	>	Large Flange Nut, 3/8-16UNC	4	Grade 5
5	407461	407462	407463	Sight Gauge Tube	1	Includes Items 6, 7, 9-11
6	TA814654			Reducer Bushing Poly, 1" x 1/2" NPTF	1	
7	9005558	>	>	Breather, Tank Vent	1	
8	9000104	>	>	Cable Tie	5	
9	9004547	>	>	Adapter, 1 1/2 SCH40 F x 1 1/2 NPTF	2	
10	TA814661	>	>	Reducer Bushing Poly, 1 1/2" x 1"	2	
11	9003683	>	>	Indicator Ball, Red - 1 1/4	1	
12	TA806275	>	>	Hose, 1" EPDM	A/R	Specify In Feet
13	TA814863	>	>	Adapter, Straight 3/4-14MPT x 1" Hose Shank	1	
14	TA800912	>	>	Hose Clamp, S.S.	2	
15	9006477	>	>	Adapter, 1" Male Pipe Quick Connect	1	
16	TA854886	>	>	Quick Connect Kit	1	Includes Items 17 & 18
17	TA854887	>	>	O-Ring for Quick Connect Kit	1	
18	TA854883	>	>	Clip for Quick Connect Kit	1	

Spray System & Command Center

Please visit www.unverferth.com/parts/ for the most current parts listing.

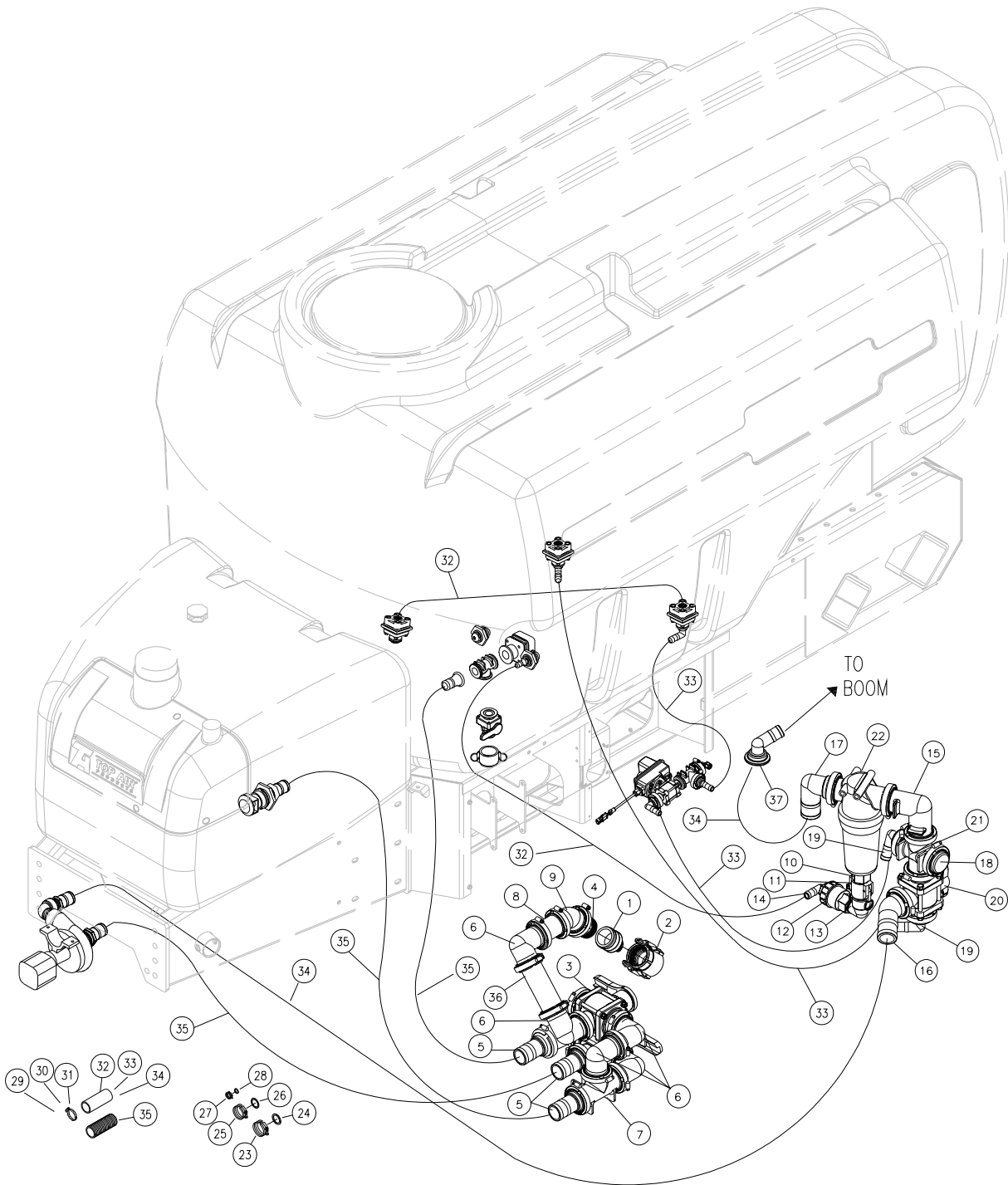

FOR BETTER VIEWING
PURPOSES, THE COMMAND
CENTER PLUMBING HAS
BEEN ROTATED 90°

Spray System & Command Center

Please visit www.unverferth.com/parts/ for the most current parts listing.

ITEM	PART NO.	DESCRIPTION	QTY.	NOTES
1	TA810625	Quick Disconnect Coupling Poly 2" Male Adapter x 2-11 1/2 NPTF Female	1	
2	TA811500	Cap Coupler Poly 2"	1	
3	TA816020	3-Way Ball Valve, 2" FP	1	
4	TA816016	Adapter, 2" Full Port Flange x 2" MPT	1	
5	TA816008	Straight 2" Full Port Flange x 2" HB	3	
6	TA816010	Elbow, 2" Full Port Flange	5	
7	TA816011	Tee, 2" Full Port Flange	1	
8	TA816014	Coupler, 2" Full Port Flange	1	
9	TA816015	Coupler, 2" Full Port Coupling 45°	1	
10	TA810550	Quick Coupler, 1"	1	
11	TA810675	Female Quick Coupler, 1"	1	
12	TA811517	Ball Valve Union, 1"	1	
13	TA814692	Street Elbow, 1"	1	
14	TA814965	Elbow, 1 NPT x 3/4 HB 90°	1	
15	TA815004	Elbow, 2" STD Flange	1	
16	9005587	45° Elbow, 2" Flange x 2" Hose Barb	1	
17	TA815021	Adapter, 2" STD Flange x 2" HB 90°	1	
18	TA815023	2" STD Flange Plug	1	
19	TA815024	2" Flange x 1" HB 90° Elbow	2	
20	TA815048	3-Way Ball Valve, 2"	1	
21	TA816019	4-Way Cross, 2"	1	
22	9010128	2" Flange Line Strainer Complete (80 Mesh)	1	
23	TA816000	Clamp, 2" Full Port Flange	A/R	
24	TA816001	Gasket, 2" Full Port Flange	A/R	
25	TA815025	Clamp, 2" Flange	A/R	
26	TA811944	Gasket, 2" Flange	A/R	
27	TA815026	Clamp, 1" Flange	A/R	
28	TA815029	Gasket, 1" Flange	A/R	
29	TA800912	Hose Clamp, 13/16" - 1 1/2"	A/R	
30	TA800910	Clamp - 1/2" Size 12 SS	A/R	
31	TA800922	Hose Clamp, 3/4" - 2 5/8" SS	A/R	
32	TA806250	Hose, 3/4" EPDM	A/R	Specify In Feet
33	TA806275	Hose, 1" EPDM	A/R	Specify In Feet
34	TA806328	Hose, 2" EPDM	A/R	Specify In Feet
35	TA806332	Hose, 2" Fertilizer Solution	A/R	Specify In Feet
36	TA816055	Coupler, 2" Full Port Coupling x 6"	1	
37	TA808520	2" Hose Barb Elbow	1	

Solution Tank Quick Fill

Please visit www.unverferth.com/parts/ for the most current parts listing.

Model 1200

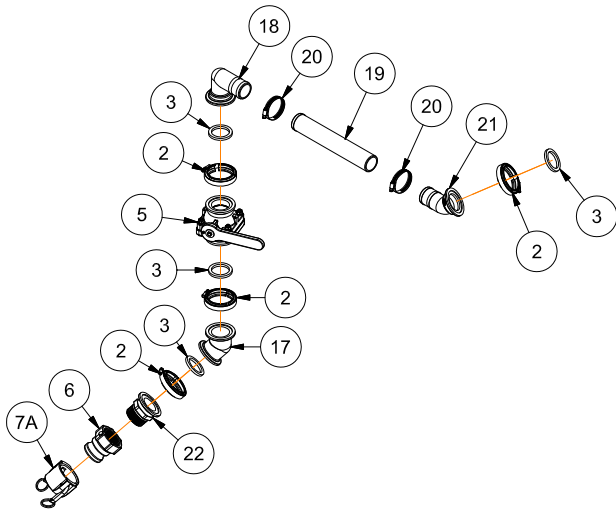

Model 1600

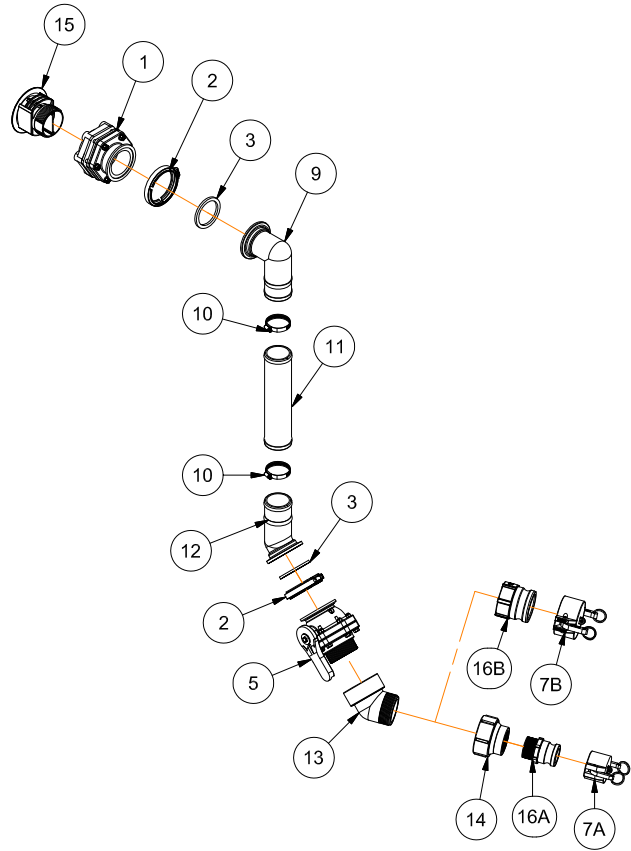

Model 2400

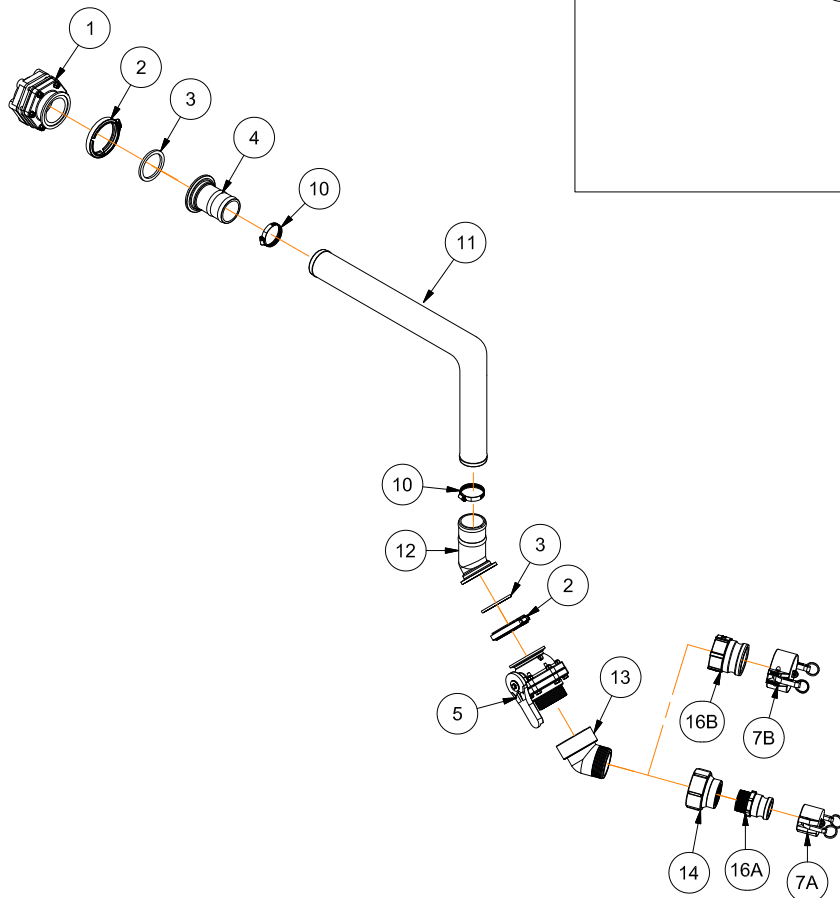

Sprayer TA1200 / TA1600 / TA2400 — Parts

Solution Tank Quick Fill

Please visit www.unverferth.com/parts/ for the most current parts listing.

ITEM	PART NO.			DESCRIPTION	QTY.			NOTES
	1200	1600	2400		1200	1600	2400	
1	-	TA816042	TA816042	Tank Flange Manifold 3" Flange x 3" NPTF	-	1	1	
2	TA816000	TA816039	TA816039	Clamp/Flange	4	2	2	
3	TA816001	TA816038	TA816038	Gasket EPDM	4	2	2	
4	-	-	TA816047	Straight Hose Barb 3" Flange x 3" Hose Shank	-	-	1	
5	9006056	TA816041	TA816041	Stubby Valve	1	1	1	
6	TA810625	-	-	Quick Disconnect Coupling Poly 2" Male Adapter x 2-11 1/2 NPTF	1	-	-	
7A	TA811500	TA811500	TA811500	Cap Coupler Poly 2"	1	1	1	
7B	-	TA811816	TA811816	Quick Disconnect Cap 3"	-	1	1	Does Not Use Item #14
8	TA0-903700-0	TA0-903700-0	TA0-903700-0	End Fill Chain Size 12	A/R	A/R	A/R	Not Shown Specify in Feet
9	-	9005533	-	90° Elbow 3" Flange x 3" HB	-	1	-	
10	-	TA800926	TA800926	Hose Clamp 1 3/4" To 3 3/4" SS	-	2	2	
11	-	TA806334	TA806334	3" Fertilizer Solution Hose	-	A/R	A/R	Specify in Feet
12	-	9005528	9005528	45° Elbow 3" Flange x 3" HB	-	1	1	
13	-	TA814730	TA814730	45° Elbow 3" Male x 3" Female	-	1	1	
14	-	TA814719	TA814719	Reducer Coupling 3-8 NPTF Female x 2-11 1/2 NPTF Female	-	1	1	Not Used When Using The 3" Adapter & Quick Disconnect Coupler
15	-	TA816053	-	3" Anti-Vortex Plug	-	1	-	Not Shown
16A	-	TA811250	TA811250	Coupler 2" NPTM/Male Threads	-	1	1	
16B	-	TA811810	TA811810	Quick Disconnect Coupling 3" Male Adapter x 3-8 NPTF	-	1	1	Does Not Use Item #14
17	TA816015	-	-	45° Elbow, 2" FP x 2" FP	1	-	-	
18	TA816009	-	-	90° Elbow, 2" FP x 2" HB	1	-	-	
19	TA806332	-	-	2" Fertilizer Solution Hose	A/R	-	-	
20	TA800922	-	-	Hose Clamp 3/4" To 2 5/8" SS	2	-	-	
21	9005845	-	-	45° Elbow, 2" HB to 2" HB	1	-	-	
22	TA816016	-	-	Adapter 2" FP Flange x 2" MP	1	-	-	

Spray Pump - ACE (304 PWM / 206) & Optional HYPRO

Please visit www.unverferth.com/parts/ for the most current parts listing.

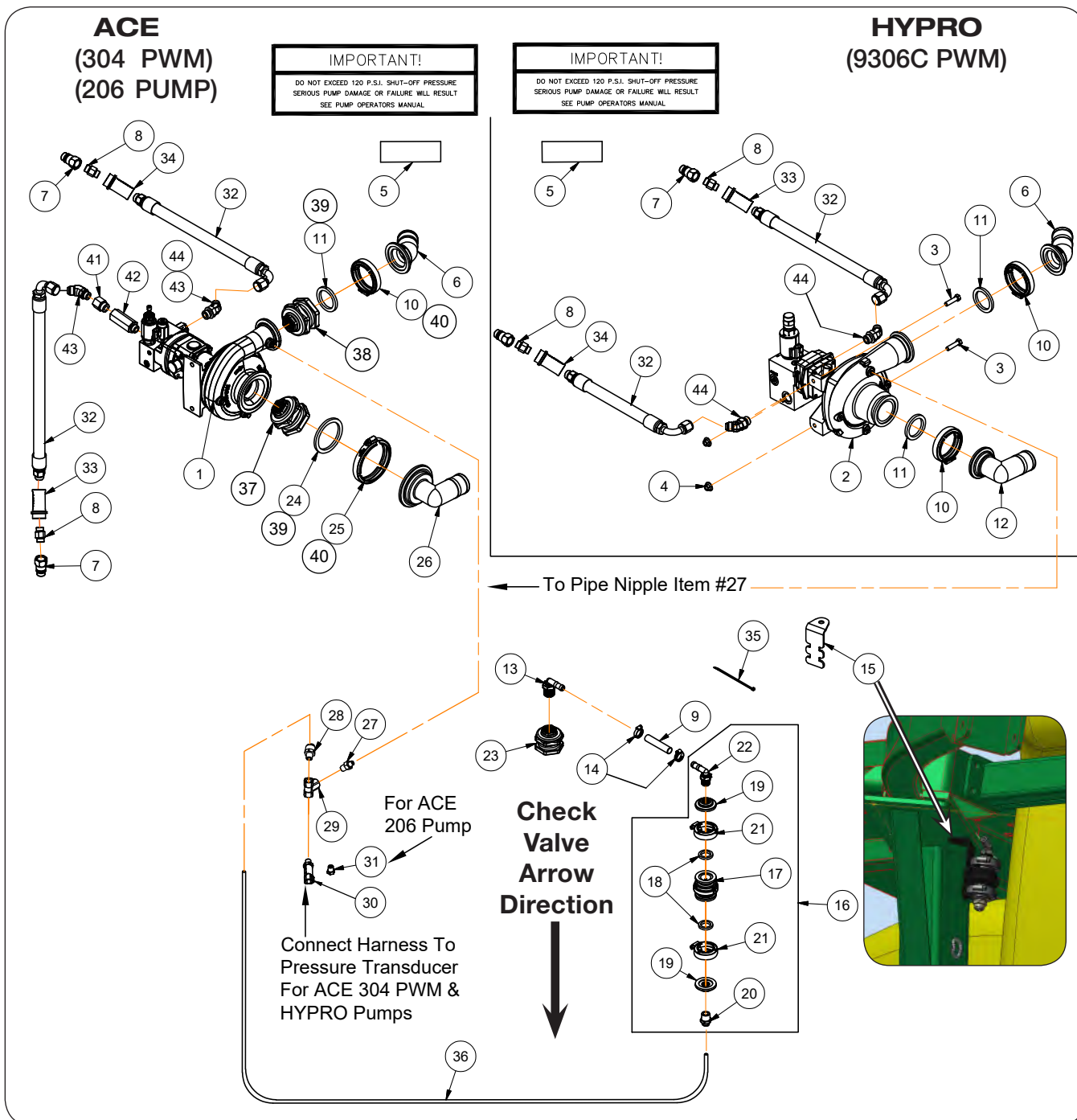

ITEM	PART NO.	DESCRIPTION	QTY.	NOTES
1	9007100	Spray Pump, ACE (304 PWM)	1	80,90,110,120,132' Booms
	TA825250	Spray Pump, ACE (206)	1	60' Boom
2	9007141	Spray Pump, HYPRO (9306C PWM)	1	Opt/80,90,110,120,132' Booms
3	9390-057	Capscrew, 3/8-16UNC x 1 1/2 Grade 5	2	
4	91263	Large Flange Hex Nut, 3/8-16UNC Grade 5	2	
5	TA510212	Decal, "Important" (Hydraulic Pressure)	1	

Sprayer TA1200 / TA1600 / TA2400 — Parts

Spray Pump - ACE (304 PWM / 206) & Optional HYPRO

Please visit www.unverferth.com/parts/ for the most current parts listing.

ITEM	PART NO.	DESCRIPTION	QTY.	NOTES
6	9005845	45° Elbow, 2" Flange x 2" Hose Barb	1	For ACE Pump (304) & HYPRO Pump
	9005587		1	For ACE Pump (206)
7	95477	Male Tip, 7/8-14 O-Ring For 3/4" Hose	2	
8	99955	Adapter, 7/8"-14 SAE Male O-R Both Ends	2	
9	TA806225	Hose 1/2" EPDM	A/R	Specify in Feet
10	TA816000	Worm Screw Flange Clamp 2"	1 / 2	ACE Pump (304) QTY 1 & HYPRO QTY 2
11	TA816001	Gasket - 2" EPDM	1 / 2	ACE Pump (304) QTY 1 & HYPRO QTY 2
12	TA816009	90° Elbow, 2" Flange x 2" Hose Barb	1	For HYPRO Pump
13	TA814960	90° Elbow 3/4-14 NPTF Male x 1/2 Hose Shank	1	
14	TA800902	Hose Clamp, 7/8" Stainless Steel	2	
15	411079B	Vent Bracket =Black=	1	
16	411078	Air Vent Assembly	1	Includes Items 17 through 22
17	9007339	1" Flange Check Valve	1	
18	TA815029	Gasket - 1" EPDM	2	
19	TA816023	1" Flange Plug x 1/2" FPT	2	
20	9007340	3/8" Push to Connect x 1/2" MNPT	1	
21	TA815026	Flange Clamp 1" Worm Screw	2	
22	TA814956	90° Elbow 1/2-14 NPTF Male x 1/2 Hose Shank	1	
23	TA805408	Manifold Fitting 3/4" Double Threaded	1	1 5/8" Hole Required
24	TA816038	Gasket - 3" EPDM	1	For ACE Pump (304)
25	TA816039	Worm Screw Flange Clamp 3"	1	For ACE Pump (304)
26	9005844	90° Elbow, 3" Flange x 2" Hose Barb	1	For ACE Pump (304)
	TA815021	90° Elbow, 2" Flange x 2" Hose Barb	1	For ACE Pump (206)
27	9007182	Pipe Nipple, 1/4" NPT x 1/8" NPT (Stainless Steel)	1	
28	TA750120	Quick Coupler 1/4-18 NPT x 3/8" Push to Connect	1	
29	TA809190	Poly Pipe Tee, 1/4"	1	
30	9503299	Pressure Transducer 1-5 VOLT, 0-250 PSI	1	For ACE Pump (304) & HYPRO Pump
31	TA809875	Hex Plug, 1/4" NPT	1	For ACE Pump (206)
32	9009306	Hose 3/4 x 150 90° Swivel 7/8-14 Male O-Ring x 7/8-14 Male O-Ring	2	
33	9010049	Hose Grips - Blue (+ Retract Port)	1	Pump Supply
34	9010050	Hose Grips - Blue (- Extend Port)	1	Pump Return
35	9000106	Cable Tie	A/R	
36	TA750051	3/8" OD Tubing	A/R	Specify in Feet
37	TA815010	Adapter 2" Flange x 1 1/2" Male NPTF	1	For ACE Pump (206)
38	TA815009	Adapter 2" Flange x 1 1/4" Male NPTF	1	For ACE Pump (206)
39	TA811944	Gasket - 1 5/8" Dia.	2	For ACE Pump (206)
40	TA815025	Worm Screw Flange Clamp 2"	2	For ACE Pump (206)
41	91035	Adapter 3/4-3/4-16 O-Ring Female x 1/2-14 Male NPTF	2	For ACE Pump (206)
42	9005187	Flow Limiter	1	For ACE Pump (206)
43	9009307	45° Elbow, 3/4-16 O-Ring Male x 7/8-14 JIC Male	1 / 2	ACE Pumps (304) QTY 1 & (206) QTY 2
44	9502614	45° Elbow, 7/8-14 JIC Male x 7/8-14 O-Ring Male	1 / 2	ACE Pump (304) QTY 1 & HYPRO QTY 2

Spray Pump - (ACE HYD 750 PWM Plumbing)

Please visit www.unverferth.com/parts/ for the most current parts listing.

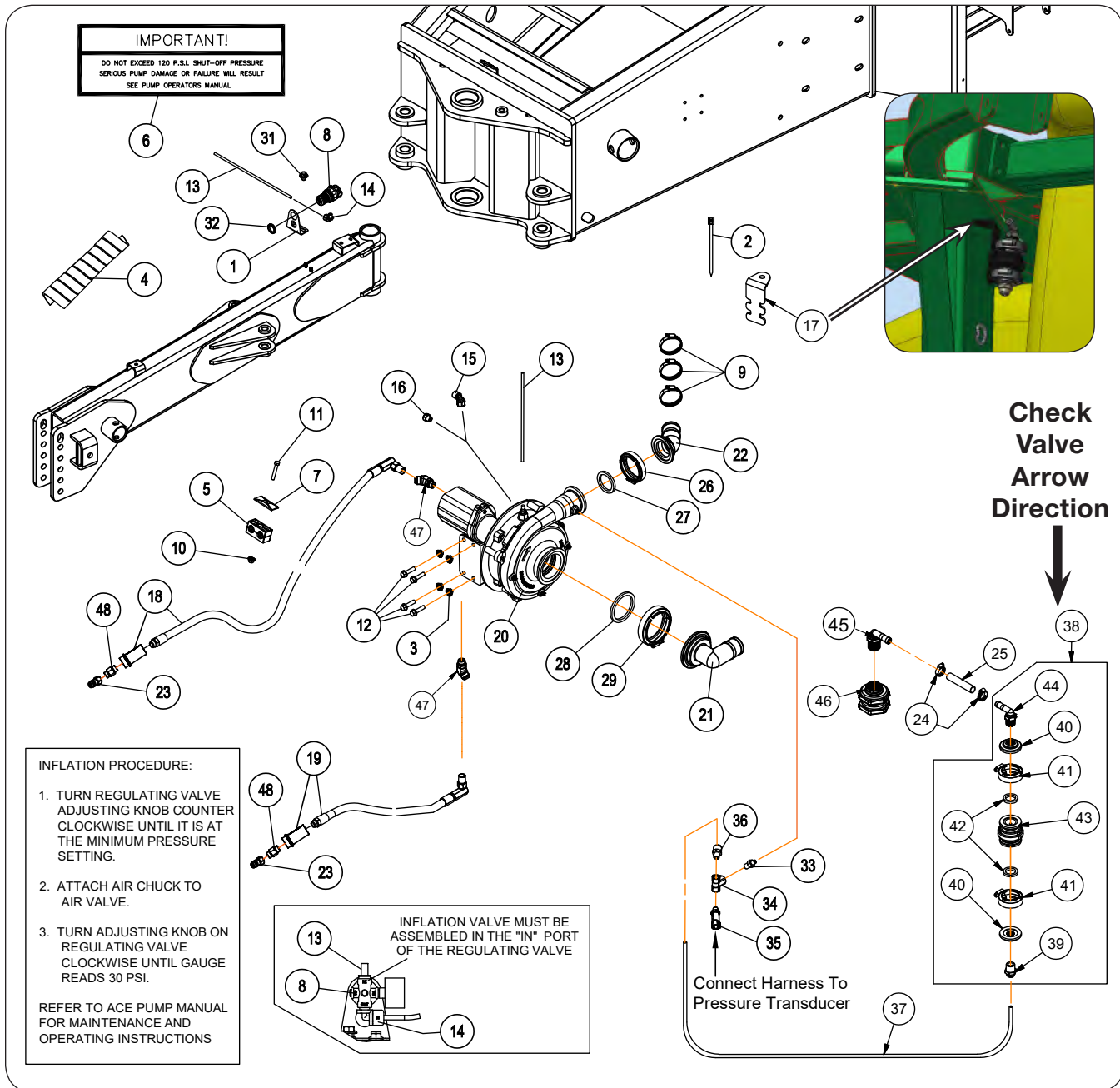

ITEM	PART NO.	DESCRIPTION	QTY.	NOTES
1	407597B	Regulator Bracket =Black=	1	
2	9000106	Cable Tie, 6" Lg.	4	
3	91263	Large Flange Nut, 3/8-16UNC G5	6	
4	9004075	Spiral Hose Wrap	A/R	
5	9007372	Poly Double Hose Clamp	1	
6	TA510212	Decal, "IMPORTANT"	1	
7	9007373	Top Plate for Hose Clamp	1	
8	408097	Regulating Valve	1	
9	TA800922	Hose Clamp, SS (SC-36)	3	
10	91257	Large Flange Hex Nut 5/16-18UNC	1	

Sprayer TA1200 / TA1600 / TA2400 — Parts

Spray Pump - (ACE HYD 750 PWM Plumbing)

Please visit www.unverferth.com/parts/ for the most current parts listing.

ITEM	PART NO.	DESCRIPTION	QTY.	NOTES
11	9390-036	Capscrew 5/16-18UNC x 2 1/2 G5	1	
12	9390-056	Capscrew 3/8-16UNC x 1 1/4 G5	4	
13	TA720620	Gauge Tubing 1/4" Dia.	A/R	
14	TA720802	90° Elbow 1/4" NPT x 1/4" Gauge Tube	1	
15	TA720812	90° Elbow 1/4" FPT x 1/4" Gauge Tube	1	
16	TA809325	1/4" Close Nipple	1	
17	411079B	Vent Bracket =Black=	1	
18	9010049	Hose Grips - Blue (+ Retract Port)	1	Pump Supply
	9009303	Hose 3/4" x 232" (3000 PSI)	1	
19	9010050	Hose Grips - Blue (- Extend Port)	1	Pump Return
	9009303	Hose 3/4" x 232" (3000 PSI)	1	
20	9008132	ACE 750 Hydraulic PWM Pump	1	
21	9005844	90° Elbow 3" Flange x 2" Hose Barb	1	
22	9005845	45° Elbow 2" Flange x 2" Hose Barb	1	
23	95477	Male Tip, 7/8-14 O-Ring	2	
24	TA800902	Hose Clamp M-6 Stainless Steel	1	
25	TA806225	Hose 1/2" EPDM	A/R	Specify in Feet
26	TA816000	Worm Screw Flange Clamp 2"	1	
27	TA816001	Gasket 2"	1	
28	TA816038	Gasket 3"	1	
29	TA816039	Worm Screw Flange Clamp 3"	1	
31	9006040	Flange Screw, 3/8-16UNC x 1/2 Gr.5	2	
32	9006051	Regulator Metal Panel Nut	1	
33	9007182	Pipe Nipple, 1/4" NPT x 1/8" NPT	1	Stainless Steel
34	TA809190	Poly Pipe Tee, 1/4"	1	
35	9503299	Pressure Transducer 1-5 VOLT, 0-250 PSI	1	
36	TA750120	Quick Coupler 1/4-18 NPT x 3/8" ID	1	
37	TA750051	3/8" OD Tubing	A/R	Specify in Feet
38	411078	Air Vent Assembly	1	Includes Items 39 through 44
39	9007340	3/8" Push to Connect x 1/2" MNPT	1	
40	TA816023	1" Flange Plug x 1/2" FPT	1	
41	TA815026	Flange Clamp 1" Worm Screw	1	
42	TA815029	Gasket - 1" EPDM	1	
43	9007339	1" Flange Check Valve	1	
44	TA814956	90° Elbow 1/2-14 NPTF Male x 1/2 Hose Shank	1	
45	TA814960	90° Elbow 3/4-14 NPTF Male x 1/2 Hose Shank	1	
46	TA805408	Manifold Fitting 3/4" Double Threaded	1	1 5/8" Hole Required
47	9502614	45° Elbow, 7/8"-14 JIC Male x 7/8"-14 Male	2	
48	99955	Adapter, 7/8"-14 SAE Male O-R Both Ends	2	

PWM Pump - (ACE 750 PWM & ACE 755)

Please visit www.unverferth.com/parts/ for the most current parts listing.

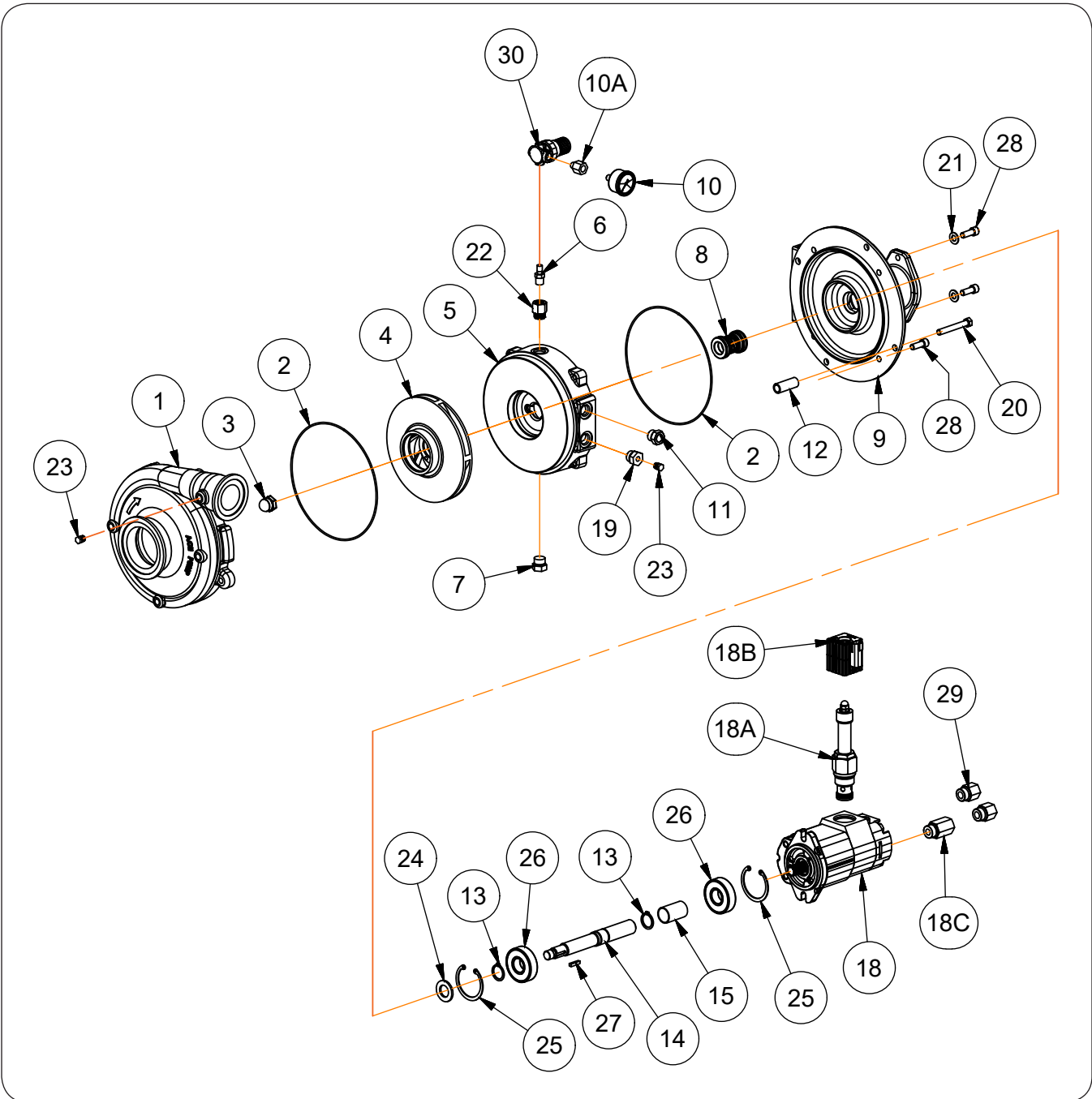

Sprayer TA1200 / TA1600 / TA2400 — Parts

PWM Pump - (ACE 750 PWM & ACE 755)

Please visit www.unverferth.com/parts/ for the most current parts listing.

ITEM	PART NO.	DESCRIPTION	QTY.	NOTES
	9008132	PWM Pump, 750	1	For Standard Pump 750
	9008739	PWM Pump, 755 (Stainless Steel)		For Stainless Steel Pump 755
1	9005502	Volute, 300 x 220 Flange	1	For Standard Pump 750
	9008855	Volute, 300 x 220 Flange (Stainless Steel)		For Stainless Steel Pump 755
2	9005503	O-Ring	2	
3	9005504	Acorn Nut, 5/8-11 SS	1	
4	9005505	Impeller	1	For Standard Pump 750
	9008856	Impeller (Stainless Steel)		For Stainless Steel Pump 755
5	9005506	Seal Plate	1	For Standard Pump 750
	9008853	Seal Plate (Stainless Steel)		For Stainless Steel Pump 755
6	9005507	Air Valve, Clamp-In (for Tubeless Tire)	1	
7	9005508	Plug	1	
8	9005509	Dual Seal Assembly	1	
9	9005510	Pump Mounting Frame	1	
10	9008866	Pump Pressure Gauge	1	
11	9005512	Oil Level Sight Gauge	1	
12	9005513	Spacer Tube	4	For Standard Pump 750 ONLY
13	9005514	Snap Ring	2	
14	9005515	Pump Shaft	1	
15	9005516	Shaft Spacer	1	
16	9005518	Royal Purple Barrier Fluid (Quart)	1.32	Qty. in quarts
17	9005519	Liquid Side Pump Seal Kit, ACE 750	1	Includes Items 2, 8 and 16
18	9008148	PWM Hydraulic Motor Assembly	1	
	9005781	Seal Kit	1	
18A	9008228	Valve	1	
18B	9008229	Coil	1	
18C	9007530	Reverse Check Assembly	1	
19	9008257	Adapter Plug, 3/4 x 1/8	1	
20	900900-062	Capscrew, 3/8-16UNC x 2 3/4 (Stainless Steel)	4	For Standard Pump 750
	900900-061	Capscrew, 3/8-16UNC x 2 1/2 (Stainless Steel)		For Stainless Steel Pump 755
21	900902-037	Flat Washer, 3/8	3	
22	99928	Adapter, 3/4 x 1/4	1	
23	TA826325	ACE Pipe Plug	5	
24	TA831022	Slinger, 7/8" Shaft	1	
25	TA831024	Snap Ring	2	
26	TA831026	Bearing	2	
27	TA831030	Key, .188 x .188 x .875	1	
28	TA831034	Capscrew, 3/8"NC x 1	6	
29	98801	Reducer 7/8-14 O-Ring Male x 3/4-16 O-Ring Female	2	
30	9006050	Air Regulator	1	

Spray Pump - (ACE FMCS 205F HYD 304 PWM)

Please visit www.unverferth.com/parts/ for the most current parts listing.

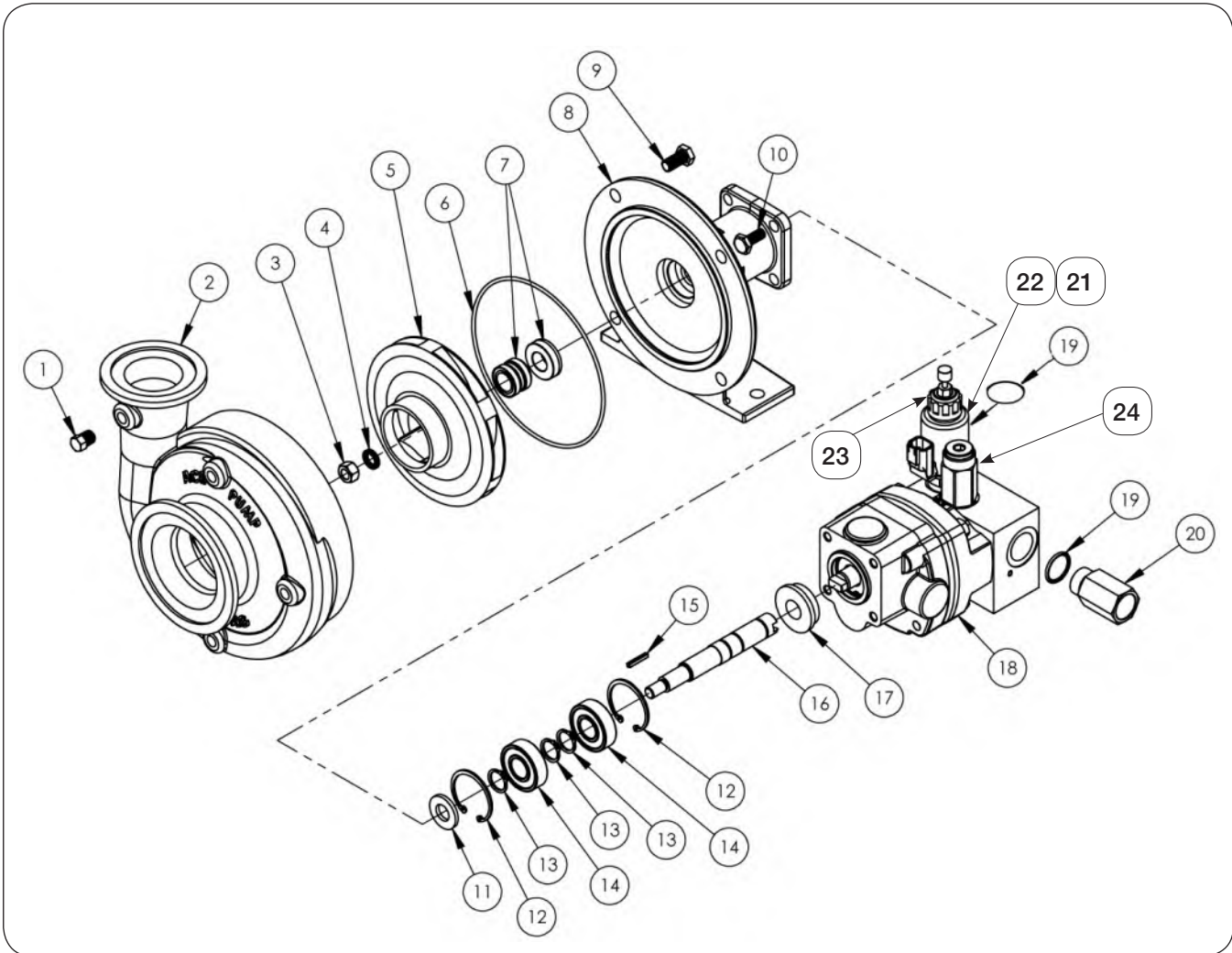

Spray Pump - (ACE FMCS 205F HYD 304 PWM)

Please visit www.unverferth.com/parts/ for the most current parts listing.

ITEM	PART NUMBER	DESCRIPTION	QTY.	NOTES
	9007100	Pump Complete, ACE FMCS-205-HYD-304	1	Includes Items 1 thru 22
1	TA826325	Pipe Plug	4	
2	9007526	Volute, 300 Standard Flange x 220 Full Port Flange, Cast Iron	1	
	9005902	Repair Kit - FMC-205 Pump w/Carbide Shaft Seal & O-Ring	-	Includes Items 6 & 7
3	900901-005	Hex Nut, 3/8"-24UNF, Stainless Steel	1	
4	9007531	Washer, 3/8", Stainless Steel, Self-Locking	1	
5	TA827920	Impeller, Thermoplastic	1	
	TA830732	Impeller, Cast Iron (Optional)		
6	TA827875	O-Ring	1	
7	9005894	Silicon Carbide Seal	1	
8	9005895	Mounting Frame, 205 Pump	1	
9	9390-053	Capscrew, 3/8"-16UNC x 3/4"	4	
10	TA829300	Capscrew, 5/16"-18UNC x 3/4" (Motor to Pump)	4	
11	TA826275	Slinger	1	
12	9005897	Snap Ring, Internal	2	
13	9005898	Snap Ring, External	3	
14	9005899	Ball Bearing, Sealed	2	
15	TA830736	Key, 1/8" x 1/8" x 13/16" - Extended	1	
16	9005900	Shaft, Extended Keyway, Impeller	1	
17	9005901	Seal Support Spacer	1	
18	9007396	Hydraulic Motor, 304/205 - 11 GPM, PWM	1	
	TA830910	Repair Kit - Hydraulic Motor	-	Not Shown
19	TA831035	O-ring, #10 SAE fitting	1	
20	9007530	Reverse Check Assembly, #10 SAE x #10 SAE	1	
21	9007887	Cartridge Valve Assembly, 12-Volt Proportional	1	Includes Items 22 & 23
	22	9010200	Proportional Control Valve Normally Closed W/Manual Override	1
	23	9009262	PWM Pump Coil	1
24	9007889	Pressure Reducing Valve Assembly	1	

Spray Pump - (ACE FMCS 150 HYD 206)

Please visit www.unverferth.com/parts/ for the most current parts listing.

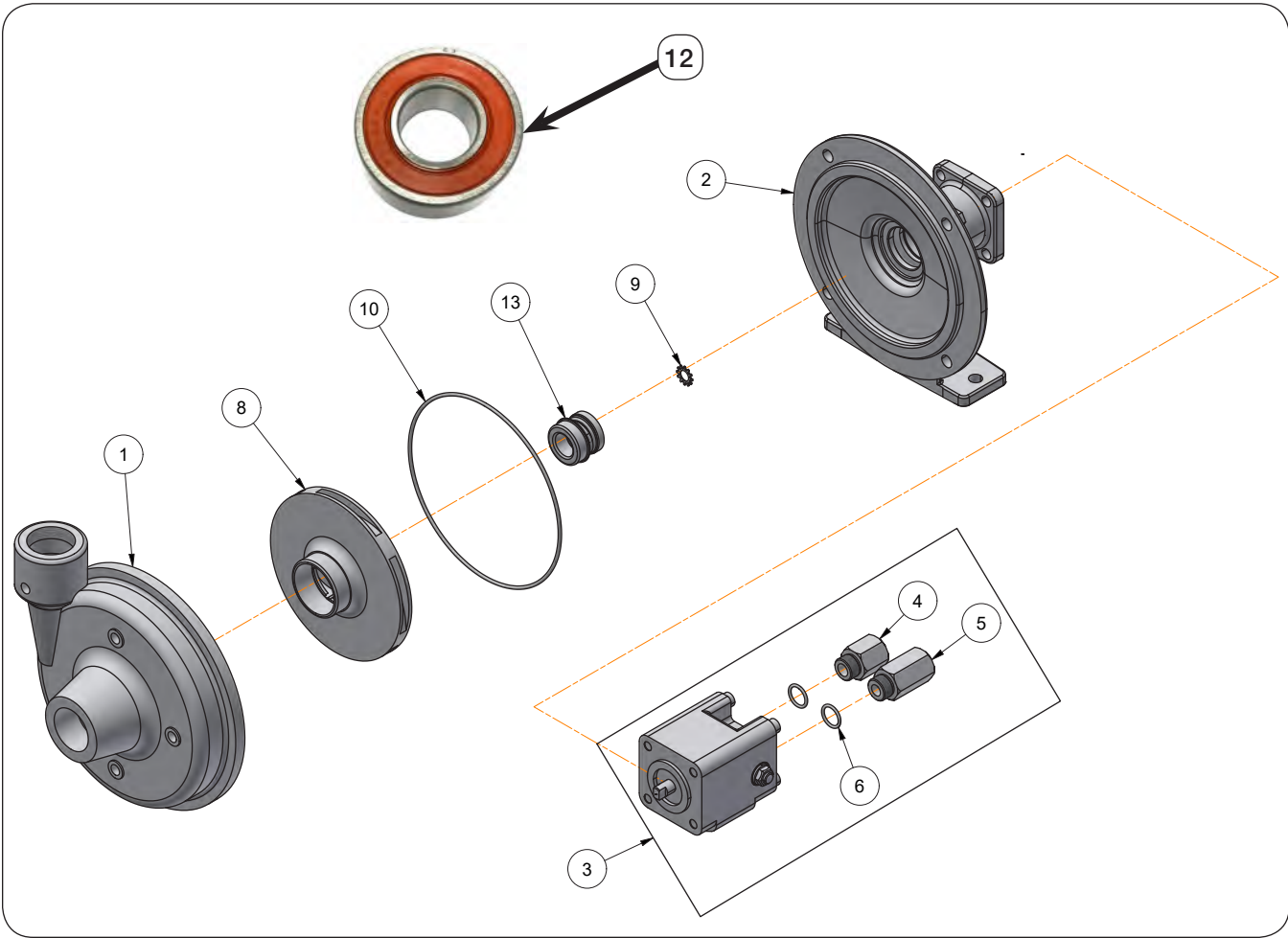

Spray Pump - (ACE FMCS 150 HYD 206)

Please visit www.unverferth.com/parts/ for the most current parts listing.

ITEM	PART NO.	DESCRIPTION	QTY.	NOTES
	TA825250	Pump Complete, ACE FMCS-150-HYD-206	1	Includes Items 1 thru 13
1	TA827910	Volute, 1 1/2" Suction & 1 1/4" Discharge	1	
2	TA829560	Mounting Frame (Black)	1	
3	TA829260	Hydraulic Motor, 206/150 - 27 GPM	1	Includes Items 4 thru 7
4	9010063	Restrictor Orifice, 1.50", #8 SAE Male	1	
5	9010062	Reverse Flow Check, 2.00", #8 SAE Male	1	
6	9840	O-Ring, 0.644" I.D	2	
7	TA830955	Seal Kit For Hyd. Motor	1	Not Shown
8	TA827918	Impeller, Thermoplastic	1	
9	TA829500	Star Washer 3/8" (Stainless Steel)	1	
10	TA827900	O-Ring Volute Seal	1	
11	9504344	Seal Kit For ACE Pump	1	Includes Items 9, 10, & 13
12	TA826725	ACE Bearing, Sealed Ball Bearing	2	
13	TA830733	Silicon Carbide Seal	1	

Spray Pump - (HYPRO 9306C-HM1C)

Please visit www.unverferth.com/parts/ for the most current parts listing.

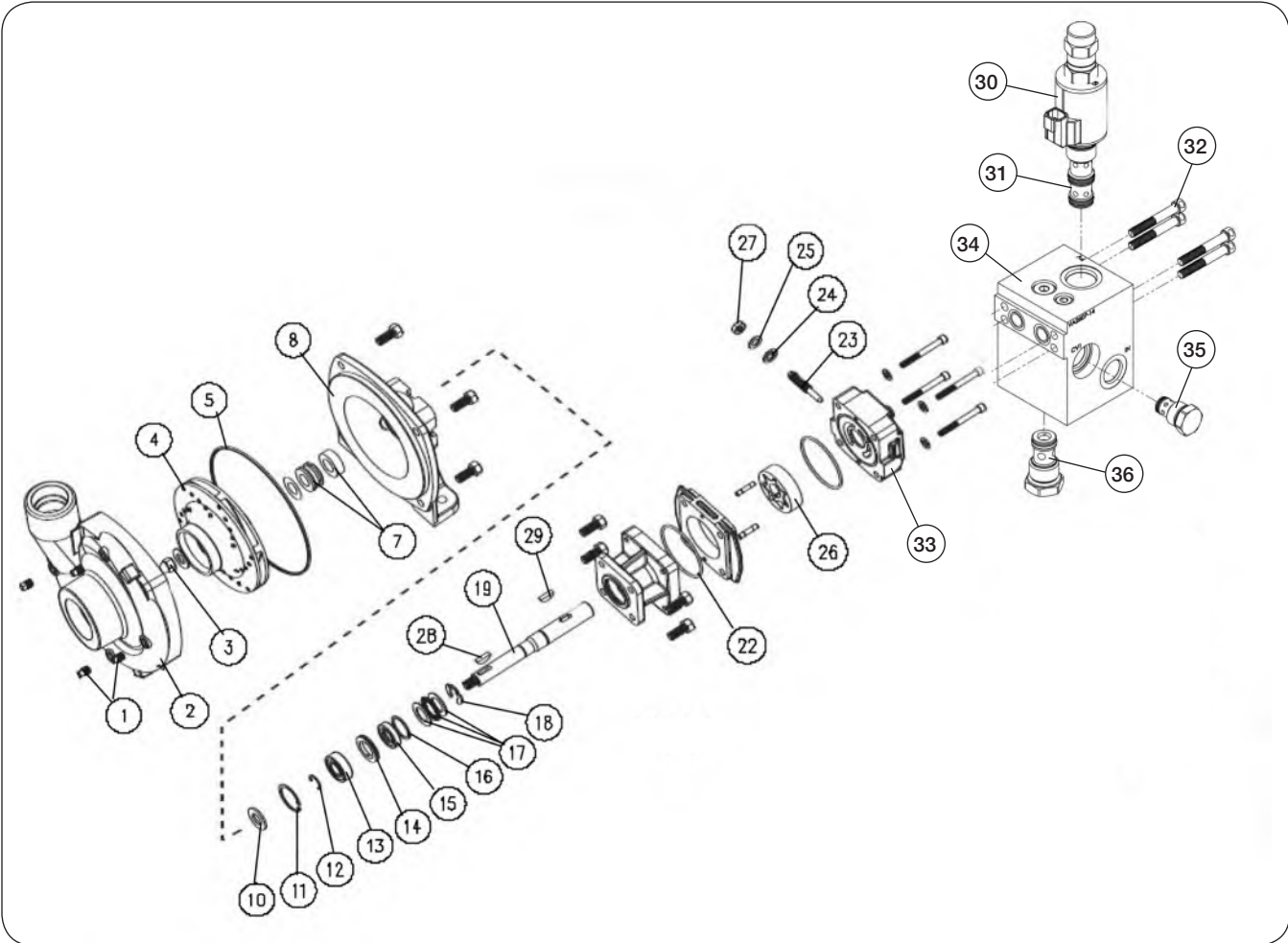

Spray Pump - (HYPRO 9306C-HM1C)

Please visit www.unverferth.com/parts/ for the most current parts listing.

ITEM	PART NO.	DESCRIPTION	QTY.	NOTES
	9007141	Pump Complete, Hypro 9306C - PWM	1	Includes Items 1 thru 29
1	TA840300	Drain Vent Plug	4	
2	-	Pump Casing	1	
3	TA840101	Impeller Nut	1	
4	TA836050	Impeller	1	
5	TA838775	O-Ring	1	
7	TA839575	Viton Seal	1	
8	TA837475	Mounting Flange	1	
9	98801	Reducer, 7/8-14 OR Male x 3/4-16 OR Female Nut	2	
10	TA838300	Slinger Ring	1	
11	TA839125	Retaining Ring	1	
12	TA839050	Snap Ring	1	
13	TA839250	Ball Bearing	1	
14	TA838325	Spacer	1	
15	TA839450	Shaft Seal	1	
16	TA838350	Seal Spacer	1	
17	TA839350	Thrust Bearing Assembly	1	
18	TA839075	Snap Ring	1	
19	TA837050	Shaft, 7"	1	
22	TA838900	O-Ring	2	
23	TA840400	Bypass Adjusting Screw	1	
24	TA838700	Gasket	1	
25	TA840225	Washer	1	
26	TA841225	Gerotor	1	
27	TA840075	Lock Nut	1	
28	TA838625	Woodruff Key	1	
29	TA838650	Roll Pin	1	
30	9007540	PWM Valve Coil	1	
31	9007538	Proportional Cartridge Valve	1	
32	9007541	Hex Capscrew	4	
33	9007535	Motor End Cover	1	
34	9007542	PWM Manifold Assembly	1	
35	9007537	Check Valve (#10)	1	
36	9007536	Check Valve (#12)	1	

Foam Marker - Optional

Please visit www.unverferth.com/parts/ for the most current parts listing.

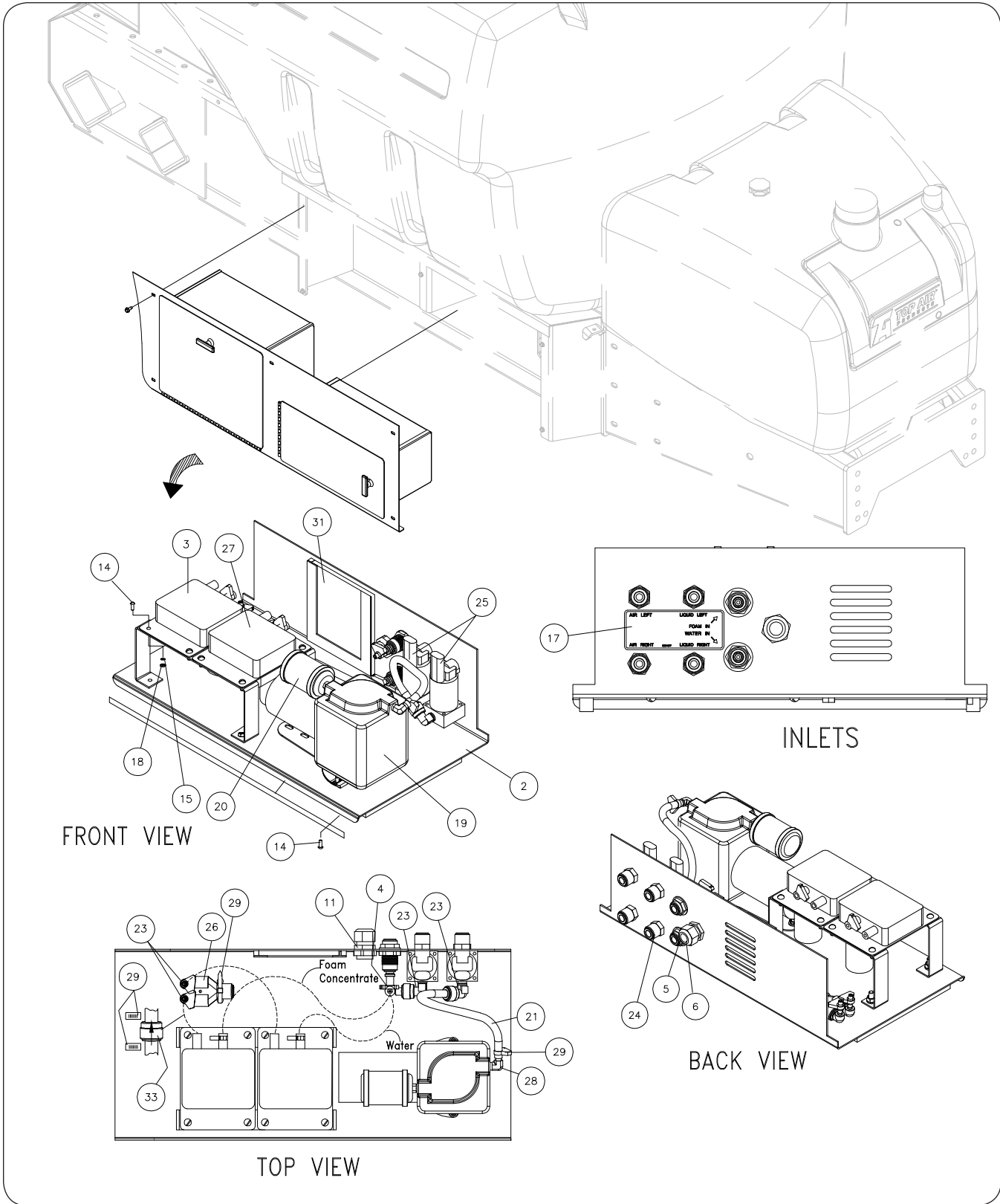

Foam Marker - Optional

Please visit www.unverferth.com/parts/ for the most current parts listing.

ITEM	PART NO.	DESCRIPTION	QTY.	NOTES
2	9005229	Tray Weldment	1	
3	9005227	Pump, Concentrate	1	
4	TA816032	Hose Barb Stem	2	
5	9003944	Bulkhead, 3/8"	2	
6	9004551	Strain Relief	1	
8	9004553	Harness Solenoid Valve	2	Not Shown
9	9004554	Wire Nut, Yellow	3	Not Shown
10	9004555	Wire Nut, Orange	2	Not Shown
11	9004556	Hex Nut, 1/2" NPT	1	
12	9390-003	Capscrew, 1/4-20UNC	4	
13	9394-002	Nut, 1/4-20UNC	4	
14	9403-022	Machine Screw, #10-24UNC	11	
15	9404-013	Lock Washer, #10	8	
16	9404-017	Lock Washer, 1/4	4	
17	9004627	Decal, Tray Marker	1	
18	9830-017	Hex Nut, #10-24	8	
19	TA750019	Compressor	1	
20	TA750020	Filter	1	
21	TA750051	Tubing, 1/4" x 3/8" Air Line	1	Specify Feet
22	9006313	In-Line Check Valve	2	Not Shown
23	TA750118	Elbow, 1/4 MPT x 3/8 HB 90°	2	
24	TA750120	Adapter	4	
25	9005223	Solenoid Valve	1	
26	TA750287	Tee, 3/8 OD Y Quick Coupler	1	
27	9005226	Pump, Water	1	
28	TA801710	Elbow, 1/8"MPTx 1/4"HB	1	
29	TA801906	Nyglass Clamp	7	
30	TA809168	Plastic Tie, 6"	1	
31	TA816029	Air Filter Square	1	
33	TA816032	Elbow, 3/8 Stem x 1/4 HB 90°	4	

Foam Marker Assembly - Optional

Please visit www.unverferth.com/parts/ for the most current parts listing.

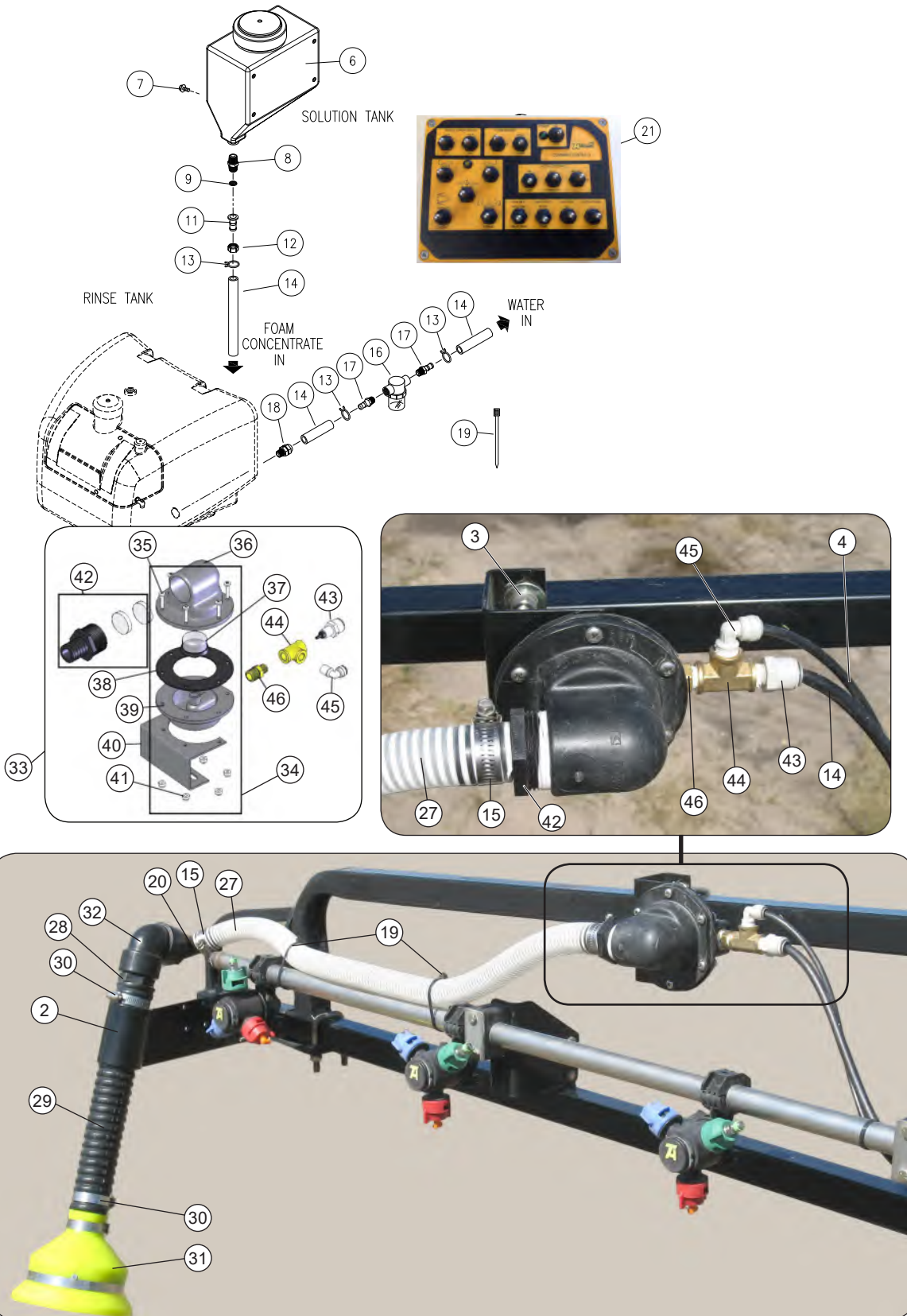

Foam Marker Assembly - Optional

Please visit www.unverferth.com/parts/ for the most current parts listing.

ITEM	PART NO.	DESCRIPTION	QTY.	NOTES
1	TA750289	Union 1/4" Hose Push-to-Connect Style	4	
2	405823B	Foamer Bracket	4 - 2	
3	9004685	U-Bolt, 3/8-16UNC for 1 1/2" Tube	4	Stainless Steel
	9004688	U-Bolt, 3/8-16UNC for 2" Tube		
	900902-038	Flat Washer, 3/8	8	
	9005640	Serrated Flange Nut, 3/8-16UNC	8	
4	TA720620	Gauge Tubing 1/4" OD	A/R	
6	9004816	Tank, Solution =Grey=	1	
7	91256	Screw/Large Flange 5/16-18UNC x 3/4	4	Grade 5
8	TA809400	Close Nipple, 3/4"	1	
9	9005604	Garden Hose Washer w/Strainer	1	
11	TA809750	Hose Barb, 1/4" Flat Seat	1	
12	TA809160	Hex Nut, 3/4" FPT	1	
13	TA750219	Squeeze Clamp	3	
14	TA750051	Nylon Tubing 3/8" OD	A/R	
15	TA800914	Hose Clamp, SC-20	4	Stainless Steel
16	TA813070	Strainer 80 Mesh Line	1	
17	TA810180	Adapter, 1/2 NPT x 1/4 Hose Barb	2	
18	TA750120	Quick Coupler, 1/4 MPT x 3/8	1	
19	9000107	Tie Strap, 12"	A/R	
20	TA814971	90° Elbow, Poly	2	
21	9007776	Control Box Command Center IV	1	
25	9004720	Flange Nut 1/4-20UNC	8 - 2	Stainless Steel
27	TA750034	Hose 1" Foam	A/R	
28	TA814869	Adapter, 1 1/4 NPTF Male x 1 1/2 Hose Barb	2	
29	TA816044	Hose 1 1/2 Collector	2	
30	TA800920	Hose Clamp, SC-32	4	Stainless Steel
31	TA750062	Collector Head, 1 1/2"	2	
32	TA814793	90° Elbow, 1 1/4 NPTF Female	2	
33	9005220	Foamhead Assembly	1	Includes Items 34-46
34	9005221	Foam Assembly	1	
35	9005209	Screw	5	
36	9005210	Top Housing	1	
37	9005211	3/8 Screen	1	
38	9005212	Gasket	1	
39	9005213	Bottom Housing	1	
40	9005214	Mounting Bracket	1	
41	9005215	Nut	5	
42	9005208	Homogenizer Nipple	1	
43	9005216	Venturi 1/4" x 3/8"	1	
44	9005217	Tee 1/4"	1	
45	9005218	90° Elbow 1/4" x 1/4"	1	
46	9005219	Adapter, 1/4" x 3/8"	1	

Double Drop Foam Marker Components - Optional

Please visit www.unverferth.com/parts/ for the most current parts listing.

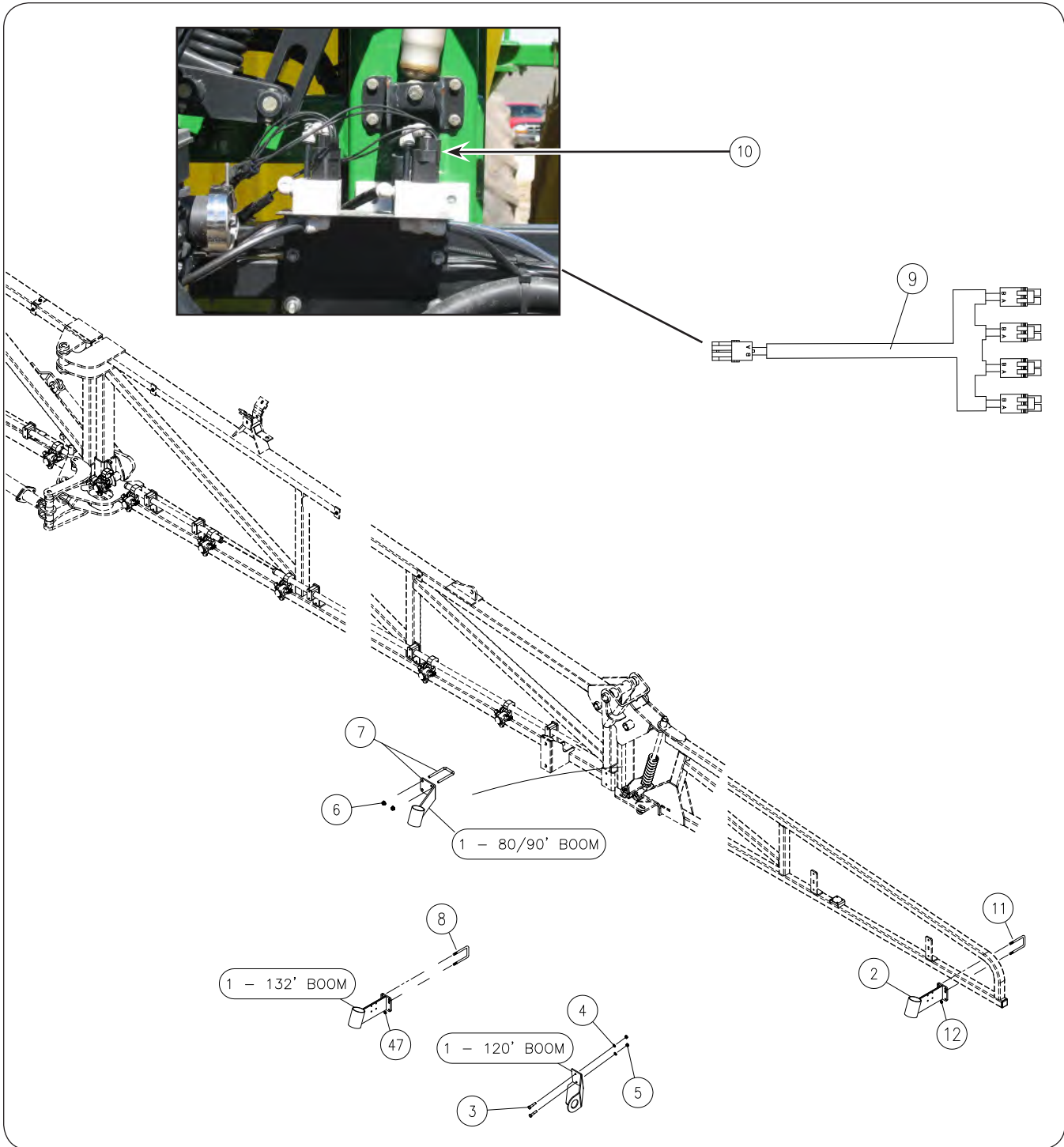

Double Drop Foam Marker Components - Optional

Please visit www.unverferth.com/parts/ for the most current parts listing.

ITEM	PART NO.			DESCRIPTION	QTY.	NOTES
	80/90' Booms	120' Boom	132' Boom			
1	407676B	405314B	-	Plate, RH Foamer Bracket =Black=	1	
	407674B	405315B	-	Plate, LH Foamer Bracket =Black=	1	
	-	404589B	-	Plate, RH Foamer Bracket =Black=	1	Model 2400
	-	404590B	-	Plate, LH Foamer Bracket =Black=	1	Model 2400
2	405823B	>	>	Foamer Bracket	4-2	
3	-	900900-030	-	Capscrew 5/16-18UNC x 1	2	Stainless Steel
4	-	900903-019	-	Lock Washer 5/16	2	Stainless Steel
5	-	900901-004	-	Hex Nut 5/16-18UNC	2	Stainless Steel
6	9005640	-	-	Serrated Flange Nut 3/8-16UNC	8	Stainless Steel
7	9004684	-	-	U-Bolt 3/8-16UNC x 4	4	Stainless Steel
8	-	9004683	-	U-Bolt 1/4-20UNC x 3 3/4	2	Stainless Steel
9	9005485	>	>	Harness, Switch	1	
10	9005203	>	>	Dual Drop Control Module Block	1	
	9005206	>	>	Dual Drop 3 Way Solenoid Valve	1	
	9005207	>	>	Dual Drop Control Module Bracket	1	
11	9004714	>	>	U-Bolt 1/4-20UNC	4	Stainless Steel
12	9004720	>	>	Flange Nut 1/4-20UNC	8	Stainless Steel

Electric Controls - Optional

Please visit www.unverferth.com/parts/ for the most current parts listing.

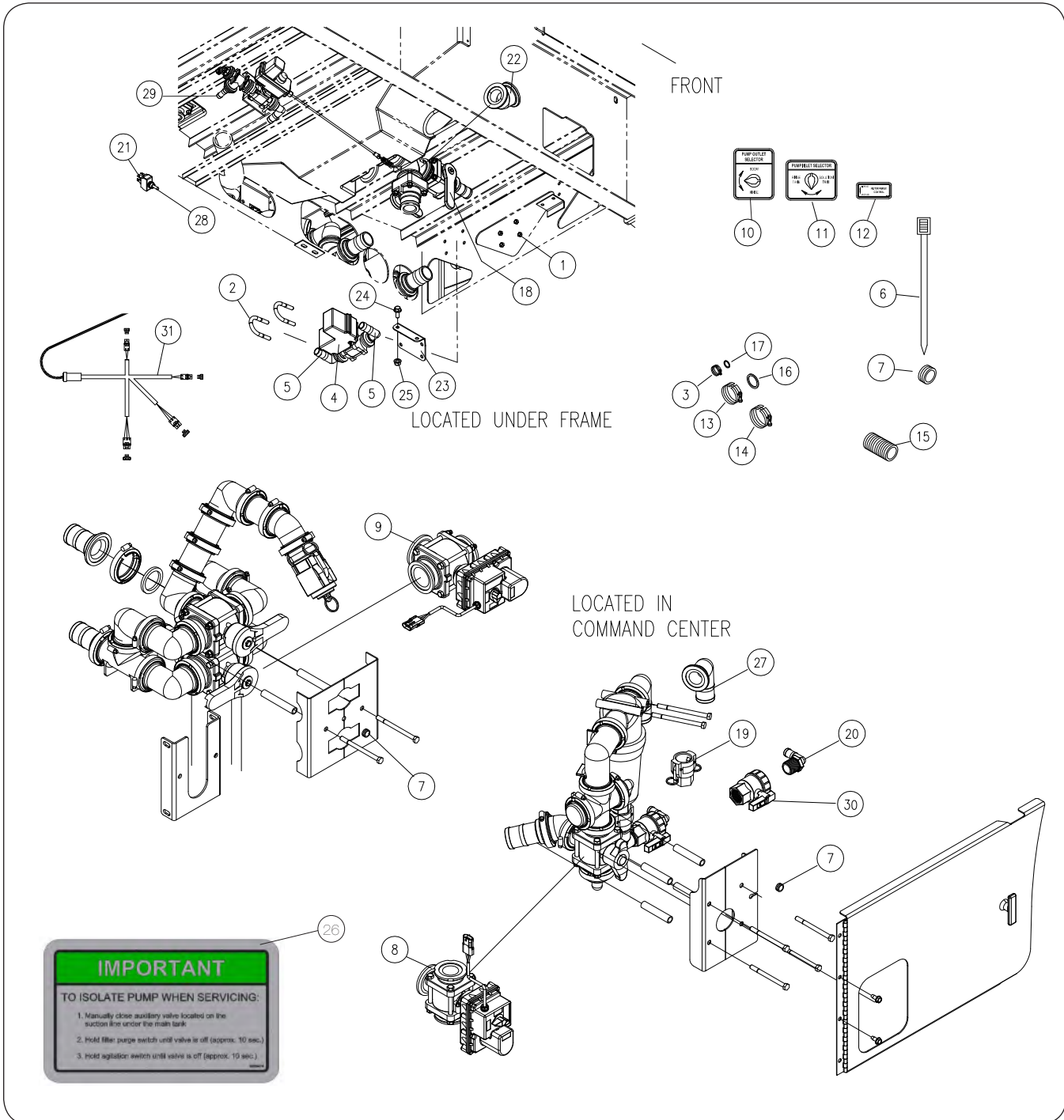

Electric Controls - Optional

Please visit www.unverferth.com/parts/ for the most current parts listing.

ITEM	PART NO.	DESCRIPTION	QTY	NOTES
	403885	Electric Control Valve Kit	1	Includes Items 1 Through 29
1	9807	Locknut, 5/16-18UNC	4	
2	100965	U-Bolt, 5/16-18UNC x 2.18 x 1.6cc	2	
3	TA815026	Clamp, 1" Flange	2	
4	9003957	Electric Ball Valve, 1" Flange	1	Includes Motor
	TA854876	Motor	1	Not Shown Separately
5	TA815017	Elbow, 1" Flange x 3/4" Hose Barb	2	
6	9000107	Cable Tie, 15 1/2	A/R	
7	9001005	Rubber Grommet	2	
8	9003955	Ball Valve, 2" STD Flange Electric	1	
9	9003956	Ball Valve, 2" Full Port Flange Electric	1	
10	9004008	Decal, Outlet Selector	1	
11	9004006	Decal, Pump Inlet	1	
12	9004560	Decal, Filter Purge Control	1	
13	TA815025	Clamp, 2" Flange	2	
14	TA800910	Clamp, 2" Full Port Flange STAINLESS STEEL	2	
15	TA806250	Hose, 3/4 EPMD	8 FT.	
16	TA811944	Gasket, 2" Flange	2	
17	TA815029	Gasket, 1" Flange	2	
18	TA815045	Ball Valve, 2" Flange	1	
19	TA810925	1" Female Coupler	1	
20	TA814965	90° Elbow, 1" NPT x 3/4" Hose Barb	1	
21	9004564	Electric Agitation Switch	1	
22	TA816004	45° Elbow, 2" Flange	1	
23	408324B	Valve Bracket =Black=	1	
24	91256	Large Flange Screw, 5/16-18UNC x 3/4 Gr.5	2	
25	91257	Large Flange Hex Nut, 5/16-18UNC	2	
26	9006474	Decal, IMPORTANT "Pump Isolation"	1	Used on Units with Electric Command Center Option
27	TA815021	90° Elbow, 2" Flange x 2" Hose Barb	1	
28	9001112	Electric Agitation Switch Rubber Seal	1	
29	TA815012	Straight Hose Barb, 1" Flange x 3/4" HS	1	
30	TA811517	Ball Valve, 1" Union	1	
31	9004550	Harness, Valve / Agitation Switch	1	

Raven ISO Tank Fill Meter

Please visit www.unverferth.com/parts/ for the most current parts listing.

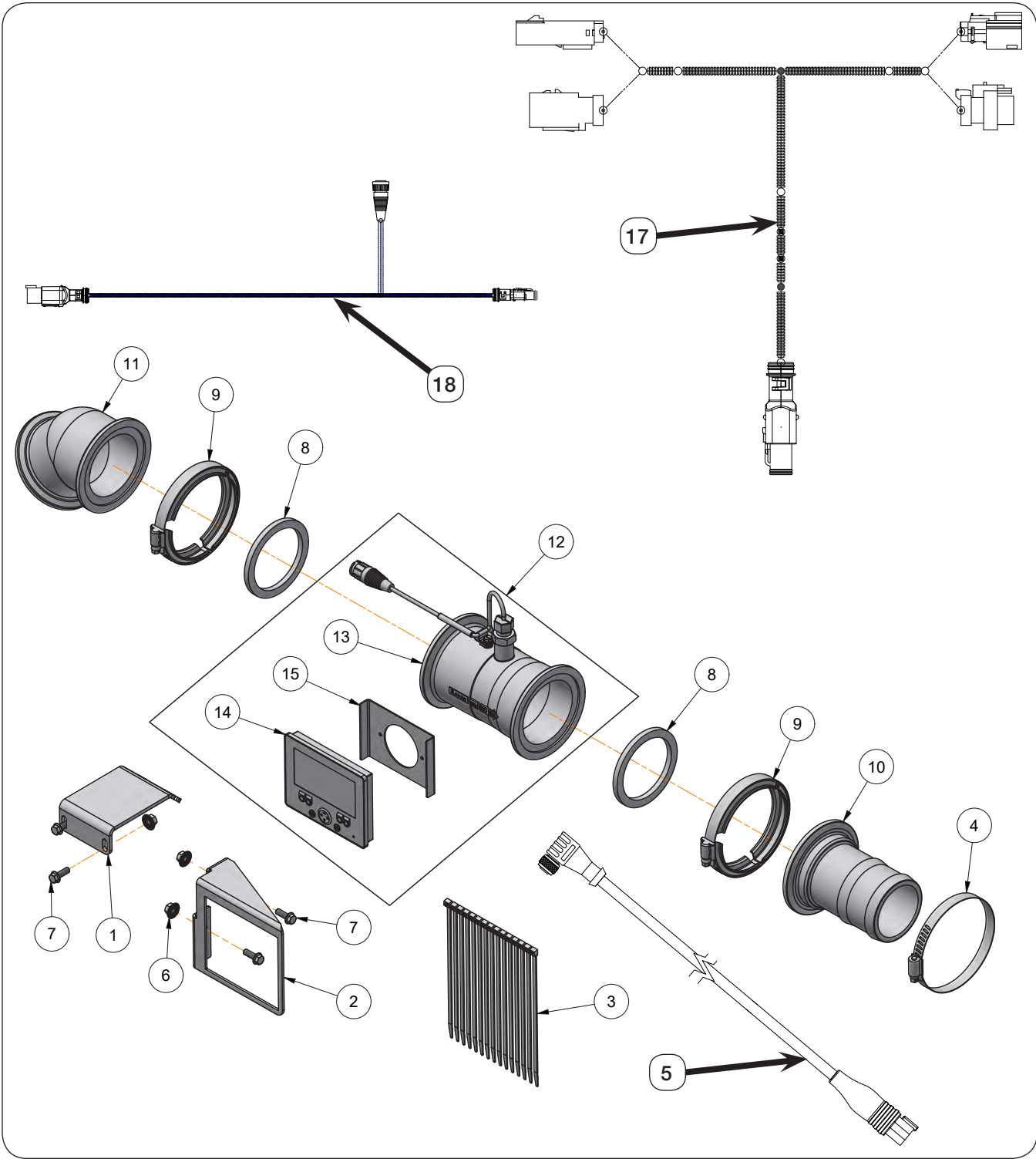

Raven ISO Tank Fill Meter

Please visit www.unverferth.com/parts/ for the most current parts listing.

ITEM	PART NO.	DESCRIPTION	QTY	NOTES	
	416582B	Raven ISO Tank Fill Kit (Black)	-	Includes All Items and Instruction Sheet	
1	414070B	Flow Meter Bracket =Black=	1		
2	416611B	Display Mounting Plate =Black=	1		
3	9000106	Cable Tie 7 1/2"	15		
4	9007462	Hose Clamp 4 1/2" Dia.	1		
5	9009916	Tank Fill Monitor Display Cable	1		
6	97189	Large Flange Hex Nut 1/4"-20UNC	4		
7	97420	Flange Screw 1/4"-20UNC x 3/4" G5	4		
8	TA816038	Gasket 3" EPDM	2		
9	TA816039	3" Flange Clamp	2		
10	TA816047	Hose Barb 3" Flange x 3" Hose Shank	1		
11	TA816049	Coupler 3" Flange x 45 Degree	1		
12	9009911	Raven ISO Tank Fill Kit	1	Includes Items 14-17 Refer to "Rate Control Module (RCM) Electrical Components" For Parts List	
	13	9007170	Raven ISO Flow Meter	1	
	14	9009914	Display Console	1	
	15	9009915	Display Mounting Bracket	1	
	16	9007759	Tank Fill Quick Reference Guide	1	Not Shown
17	9009907	JD ISO Tee to Tank Fill Monitor, Cable 10'	1		
18	9009903	Extension Cable Pump / Fill Flowmeter	1		



Scan the QR code for additional product information.



Unverferth[®]
Manufacturing Company, Inc.

www.unverferth.com