



**DRILL FILL AUGER  
FITS 30' and 40' CASE IH 500T  
and NEW HOLLAND P2085 DRILLS**

Beginning With Serial #D62870100

Part No. 2004186

## Foreword

Your new FILL AUGER is designed and manufactured to give you years of dependable service. To keep it running efficiently, read the instructions in this operator's manual.

This manual covers operation, service, assembly, and parts for your FILL AUGER. Read and study manual completely before attempting to operate this implement. Take this manual to the field for handy reference when operating, adjusting, or servicing your machine.

“Right-Hand” and “Left-Hand” side of the machine are determined by standing behind the implement and facing in the direction of forward travel.

### IMPORTANT

- *The information, specifications, and illustrations in the manual are on the basis of information available at the time it was written. Due to continuing improvements in the design and manufacture of Unverferth products, all specifications and information contained herein are subject to change without notice.*

# Drill Fill Auger — Introduction

## Product Information

Please fill out and retain this portion for your records. All products manufactured by Unverferth Mfg. Co., Inc. are warranted to be free from material and workmanship defects for one full year from time of consumer delivery. Your local dealer will gladly assist you with any warranty questions.

The serial number plate is located as shown in FIG. 1.

Product \_\_\_\_\_

Serial Number \_\_\_\_\_

Date of Purchase \_\_\_\_\_

Dealer \_\_\_\_\_

City \_\_\_\_\_ State \_\_\_\_\_ Zip \_\_\_\_\_

Please supply this information when you have questions or when ordering repair or replacement parts. Your dealer needs this information to give you prompt, efficient service.

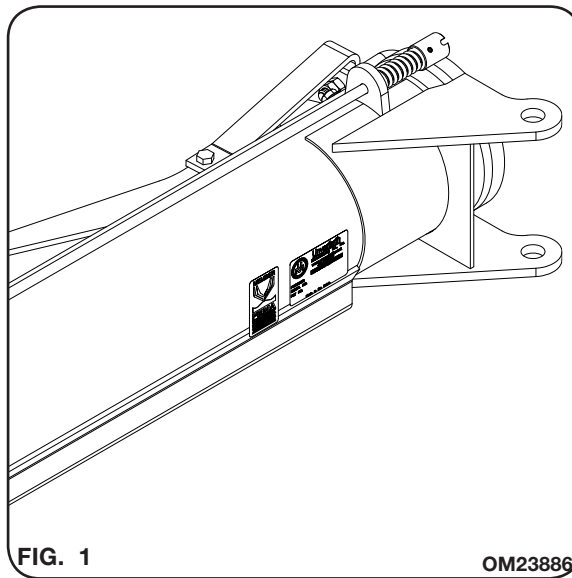

## PRE-OPERATION CHECKLIST

<input type="checkbox"/> Safety and operating procedures reviewed	<input type="checkbox"/> Field adjustment information reviewed
<input type="checkbox"/> Hardware tightened	<input type="checkbox"/> Lubrication procedures reviewed
<input type="checkbox"/> Machine lubricated	<input type="checkbox"/> Warranty information reviewed
	<input type="checkbox"/> Hydraulic hoses properly routed/fittings tight

**Table of Contents**

**SECTION I  
Safety**

General Hazard Information ..... 1-2  
Safety Decals ..... 1-3  
Following Safety Instructions ..... 1-4  
Before Operating or Servicing ..... 1-4  
During Operation ..... 1-5  
Before Transporting ..... 1-5  
During Transport ..... 1-5  
Pressurized Oil ..... 1-6  
Preparing for Emergencies ..... 1-7  
Wearing Protective Equipment ..... 1-7

**SECTION II  
Set Up**

Shipping Bundles ..... 2-2  
Auger Assembly ..... 2-3  
Mounting Bracket & Support Stand ..... 2-10  
Attaching The Auger ..... 2-20  
Hydraulics ..... 2-21  
Spout Assembly ..... 2-23  
Hydraulic Flow Control Installation (Optional) ..... 2-24  
Check Valve Kit Installation (Optional) ..... 2-25

**Table of Contents**

**SECTION III  
Operation**

Preparing Drill .....3-2  
Operating Procedures .....3-2  
Transporting .....3-5  
Hydraulic System .....3-6

**SECTION IV  
Maintenance**

Lubrication .....4-2  
Lower Auger Bearing .....4-2  
    Miscellaneous Lube Points .....4-2  
Storage/Maintenance .....4-2  
Troubleshooting .....4-3  
Torque Chart .....4-4  
Hydraulic Fittings .....4-5

**SECTION V  
Parts**

Transport & Pivot Support Stands .....5-2  
Lower Auger Components .....5-4  
Upper Auger Components .....5-6  
Hopper Components .....5-8  
Flow Control Valve Kit Components (Optional) .....5-10  
Check Valve Kit Components (Optional) .....5-11

**Notes**

# **SECTION I**

## **Safety**

General Hazard Information .....	1-2
Safety Decals .....	1-3
Following Safety Instructions .....	1-4
Before Operating or Servicing .....	1-4
During Operation .....	1-5
Before Transporting .....	1-5
During Transport .....	1-5
Pressurized Oil .....	1-6
Preparing for Emergencies .....	1-7
Wearing Protective Equipment .....	1-7

## General Hazard Information

No accident-prevention program can be successful without the wholehearted cooperation of the person who is directly responsible for the operation of the equipment.

A large number of accidents can be prevented only by the operator anticipating the result before the accident is caused and doing something about it. No power-driven equipment, whether it be transportation or processing, whether it be on the highway, in the field, or in the industrial plant, can be safer than the person who is at the controls. If accidents are to be prevented--and they can be prevented--it will be done by the operators who accept the full measure of their responsibility.

It is true that the designer, the manufacturer, and the safety engineer can help; and they will help, but their combined efforts can be wiped out by a single careless act of the operator.

It is said that, "the best kind of a safety device is a careful operator." We, at Unverferth Mfg. Co., Inc. ask that you be that kind of operator.



**REMEMBER:  
THINK SAFETY**  
A CAREFUL OPERATOR IS THE  
BEST INSURANCE AGAINST AN  
ACCIDENT!

### SIGNAL WORDS



**INDICATES AN EXTREMELY HAZARDOUS SITUATION OR ACTION  
THAT WILL RESULT IN SERIOUS INJURY OR DEATH.**



**INDICATES A HAZARDOUS SITUATION OR ACTION THAT COULD  
RESULT IN SERIOUS INJURY OR DEATH.**



**INDICATES AN UNSAFE SITUATION OR ACTION THAT MAY RESULT  
IN PERSONAL INJURY.**



*Is used for instruction on operating, adjusting, or servicing a machine.*



## Safety Decals

**⚠ WARNING** REPLACE LOST, DAMAGED, PAINTED, OR UNREADABLE DECALS IMMEDIATELY. IF PARTS THAT HAVE DECALS ARE REPLACED, ALSO MAKE SURE TO INSTALL NEW DECALS. THESE DECALS INFORM AND REMIND THE OPERATOR WITH OPERATIONAL INFORMATION AND SAFETY MESSAGES.

**⚠ DANGER**

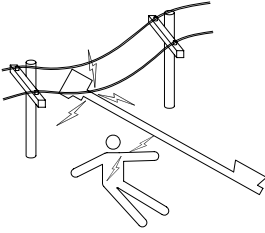

CONTACT with UTILITY LINES can cause SERIOUS INJURY or DEATH.

STAY CLEAR of all UTILITY LINES.

93558

**⚠ WARNING**



HIGH PRESSURE OIL can cause SERIOUS INJURY or DEATH.

KEEP AWAY from LEAKS. RELIEVE PRESSURE before SERVICING. Seek IMMEDIATE TREATMENT.

93551

**⚠ WARNING**



FALLING AUGER can cause SERIOUS INJURY or DEATH.

EXTEND and LOCK AUGER before removing from transport stand.

99960

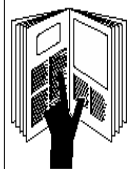

**⚠ WARNING**

READ and understand OPERATOR'S MANUAL before using this machine. Failure to follow operating instructions can result in SERIOUS INJURY or DEATH.

97961



**⚠ WARNING**

KEEP all guards or doors in place when in operation. Failure to do so could result in SEVERE INJURY or DEATH.

98766





**⚠ WARNING**



FALLING CAN CAUSE SERIOUS INJURY OR DEATH. SECURE RAILING AND CHAINS INTO WORKING POSITION BEFORE OPERATING. SEE OPERATOR'S MANUAL FOR DETAILS.

9501891

## Following Safety Instructions

- Read and understand this operator's manual, and the towing vehicle's operator's manual, before operating. 
- All machinery should be operated only by trained and authorized personnel.
- To prevent machine damage, use only attachments and service parts approved by the manufacturer.
- Always shut tractor engine off & remove key before servicing the implement. 
- Avoid personal attire such as loose fitting clothing, shoestrings, drawstrings, pants cuffs, long hair, etc., that may become entangled in moving parts.
- Never attempt to operate implement unless you are in driver's seat. 

## Before Operating or Servicing

- Do not stand between towing vehicle and implement during hitching
- Avoid working under the unit; however, if it becomes absolutely unavoidable, make sure the implement is safely blocked. 
- Always make certain everyone and everything is clear of the machine before beginning operation.
- Turn engine off and remove key from ignition before servicing or adjusting equipment. 
- Verify that all safety shields are in place and secured.
- Ensure that all applicable safety decals are installed and legible.

## During Operation

- Keep away from overhead power lines. Electrical shock can cause serious injury or death.
- Regulate speed to field conditions, maintain complete control at all times
- Use extreme care when operating close to ditches, fences, or on hillsides.
- Never lubricate equipment when in operation.
- Seed being transported may contain seed treatment. Read and follow all requirements for personal protective equipment and first aid as outlined on seed tags.
- Be sure that all safety shields are in place, and that the clean-out door is closed and securely latched.

## Before Transporting

- Install transport locks before transporting.
- Comply with state and local laws governing highway safety when moving machinery.
- Check for proper function of all available transport lights. Make sure that all reflectors are clean and in place on machine.

## During Transport

- Comply with state and local laws governing highway safety when moving machinery.
- Maximum speed of implement should never exceed 20 mph. Do not exceed 10 mph during off-highway travel.
- Use transport lights as required by local laws to adequately warn operators of other vehicles.
- Use good judgment when transporting equipment on highways. Regulate speed to road conditions and maintain complete control.

### Pressurized Oil

- Relieve pressure before disconnecting hydraulic lines from tractor, loosening any hydraulic fittings or servicing hydraulic system. See hydraulic power unit manual for procedure to relieve pressure.

---
- Use a piece of cardboard or wood to detect leaks of hydraulic fluid under pressure. Correct hydraulic leaks immediately.

---
- High-pressure fluids can penetrate the skin and cause serious injury or death. Seek medical treatment immediately if injured by high-pressure fluids.

---
- Hydraulic system must be purged of air before operating to prevent serious injury or death.

---
- Do not bend or strike high-pressure lines. Do not install bent or damaged tubes or hoses.

---
- Repair all oil leaks. Leaks can cause fires, personal injury, and environmental damage.

---
- Route hoses and lines carefully to prevent premature failure due to kinking and rubbing against other parts. Make sure that all clamps, guards and shields are installed correctly.

---
- Check hydraulic hoses and tubes carefully. Replace components as necessary if any of the following conditions are found:
  - End fittings damaged, displaced, or leaking.
  - Outer covering chafed or cut and wire reinforcing exposed.
  - Outer covering ballooning locally.
  - Evidence of kinking or crushing of the flexible part of a hose.
  - Armoring embedded in the outer cover.

## Preparing for Emergencies

- Keep a first aid kit and properly rated fire extinguisher nearby.



- Keep emergency numbers for fire, rescue, and poison control personnel near the phone.



## Wearing Protective Equipment

- Wear clothing and personal protective equipment appropriate for the job.



- Wear steel-toed shoes when operating.



- Wear hearing protection when exposed to loud noises.



- Do not wear additional hearing impairing devices such as radio headphones, etc.

- This product may contain a chemical known to the state of California to cause cancer, or birth defects, or other reproductive harm.

**Notes**

**SECTION II**  
**Set Up**

Shipping Bundles ..... 2-2  
Auger Assembly ..... 2-3  
Mounting Bracket & Support Stand ..... 2-10  
Attaching The Auger ..... 2-20  
Hydraulics..... 2-21  
Spout Assembly..... 2-23  
Hydraulic Flow Control Installation (Optional)..... 2-24  
Check Valve Kit Installation (Optional)..... 2-25

# Drill Fill Auger — Set Up

## Shipping Bundles

You should receive the following bundles:

### PARTS BUNDLE PART #2004182B

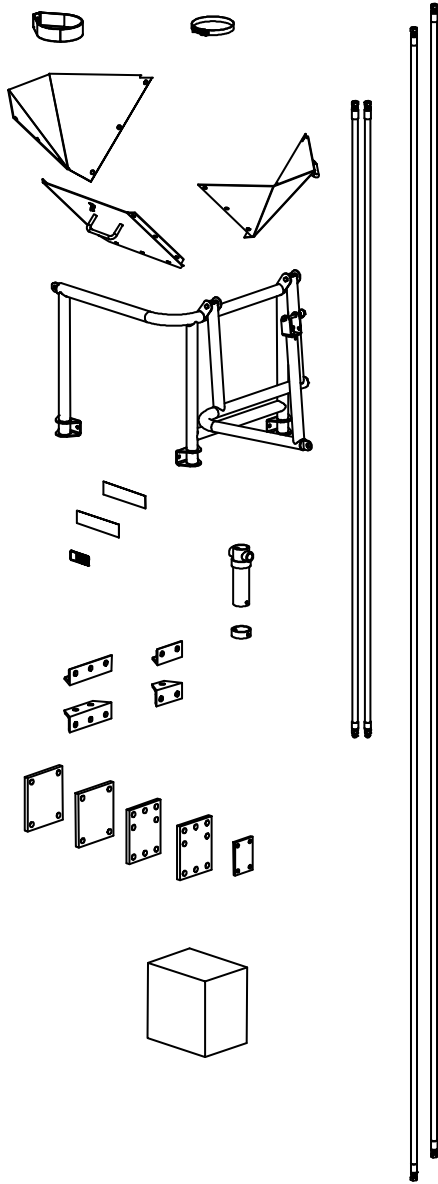

### HOPPER LID BUNDLE PART #23664

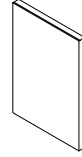

### AUGER ASSEMBLY PART #2004181B

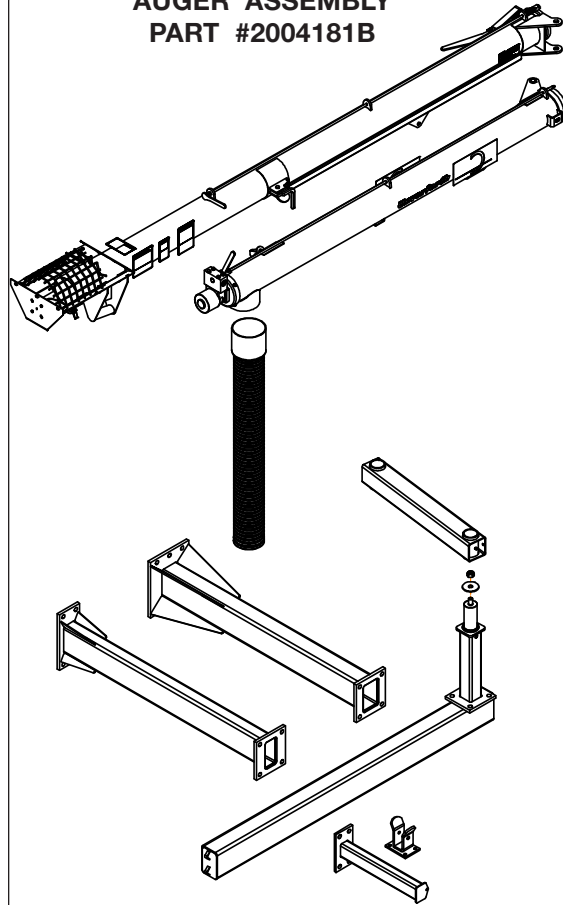

**FLIGHTING BUNDLES:**  
BRUSH - 23528B & 23534B  
STEEL - 23469B & 23479B  
PLASTIC - 26869, 900301, & 900302



## Auger Assembly

### **WARNING**

- **EYE PROTECTION AND OTHER APPROPRIATE PERSONAL PROTECTIVE EQUIPMENT MUST BE WORN WHILE SERVICING IMPLEMENT.**
- **KEEP HANDS CLEAR OF PINCH POINT AREAS.**
- **FALLING OBJECTS CAN CAUSE SERIOUS INJURY OR DEATH. DO NOT WORK UNDER THE MACHINE AT ANY TIME WHILE BEING HOISTED. BE SURE ALL LIFTING DEVICES AND SUPPORTS ARE RATED FOR THE LOADS BEING HOISTED. THESE ASSEMBLY INSTRUCTIONS WILL REQUIRE SAFE LIFTING DEVICES UP TO 500 LBS. SPECIFIC LOAD RATINGS FOR INDIVIDUAL LOADS WILL BE GIVEN AT THE APPROPRIATE TIME IN THE INSTRUCTIONS.**

This section contains all of the instructions required for the complete assembly of the entire FILL AUGER to your planter.

For your safety, and the safety of others, use proper tools and equipment and always use safe working procedures. Refer to these instructions before starting any work on your machine.

### **IMPORTANT**

- *The procedures for assembling this unit were intended for two or more people.*

For ease of assembly, install all hardware loosely until assembly is complete and then tighten according to “Torque Chart”.

Place machine on a solid level surface with sufficient clear space to unfold the wings of the machine. Unfold wings (if present), lower unit to the ground, block from moving, set the tractor brakes, shut-off the engine, and removed the ignition key.

Use a hoist and lifting devices rated at 500 lbs. minimum when handling the lower and upper augers.

1. Remove the auger halves and flighting from the shipping crate.

## Auger Assembly (Continued)

2. On the hopper end of the fill auger, install flange bearing (9735) provided in the part bundle (2004182B). Secure bearing in place using four 3/8"-16UNC x 1 1/4" capscrews (9390-056), 3/8" USS flat washers (9405-076) and 3/8"-16UNC locknuts (9928). See FIG. 2-2.
3. Using a safe lifting device rated at 50 lbs., hoist and insert the fighting shaft into the flange bearing (9735) and retain in place by tightening the set screw on the locking collar found on the flange bearing. See FIG. 2-2.

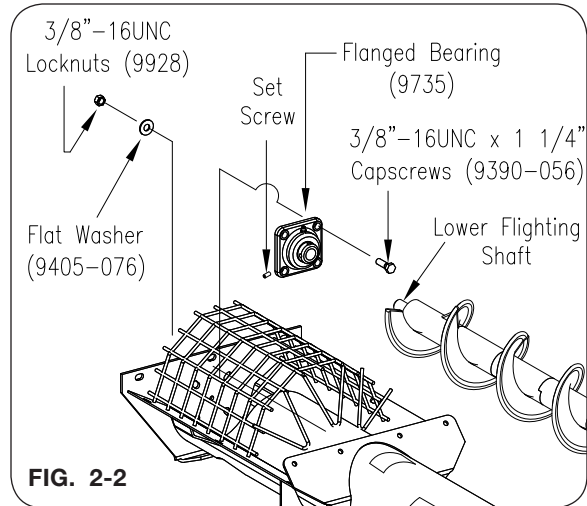

## Brush & Steel Fighting Only

4. Attach the fighting to the opposite end of the lower auger with two 3/8"-16UNC x 3/4" large flange capscrews (95585) and 3/8"-16UNC locknuts (9928) provided in parts box. See FIG. 2-3.

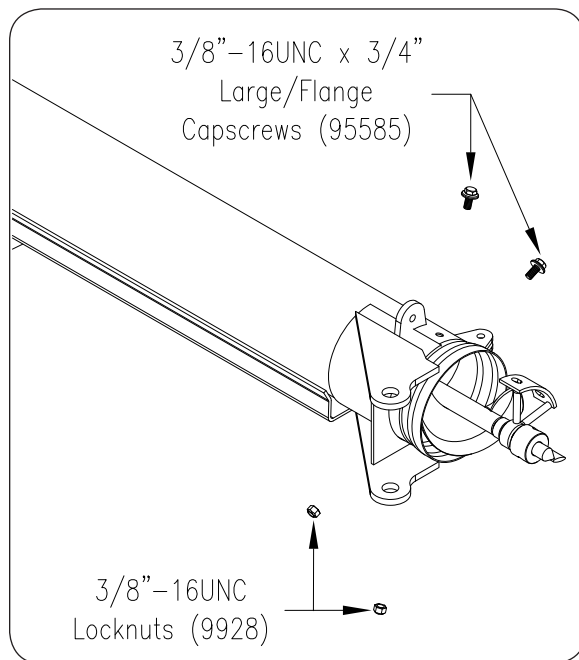

## Auger Assembly (Continued)

### Plastic Flighting Only

- 4A. Remove the two 5/16"-18UNC x 2 1/4" capscrews (91484) and 5/16"-18UNC elastic stop nuts (92929-007) from the end of the plastic flighting and insert the shaft weldment (25561B). Secure into position with the previously removed capscrews and elastic stop nuts. Attach the plastic flighting to the opposite end of the lower auger with 3/8"-16UNC x 3/4" large flange capscrews (95585) and 3/8"-16UNC locknuts (9928) provided in parts box. See FIG. 2-4.

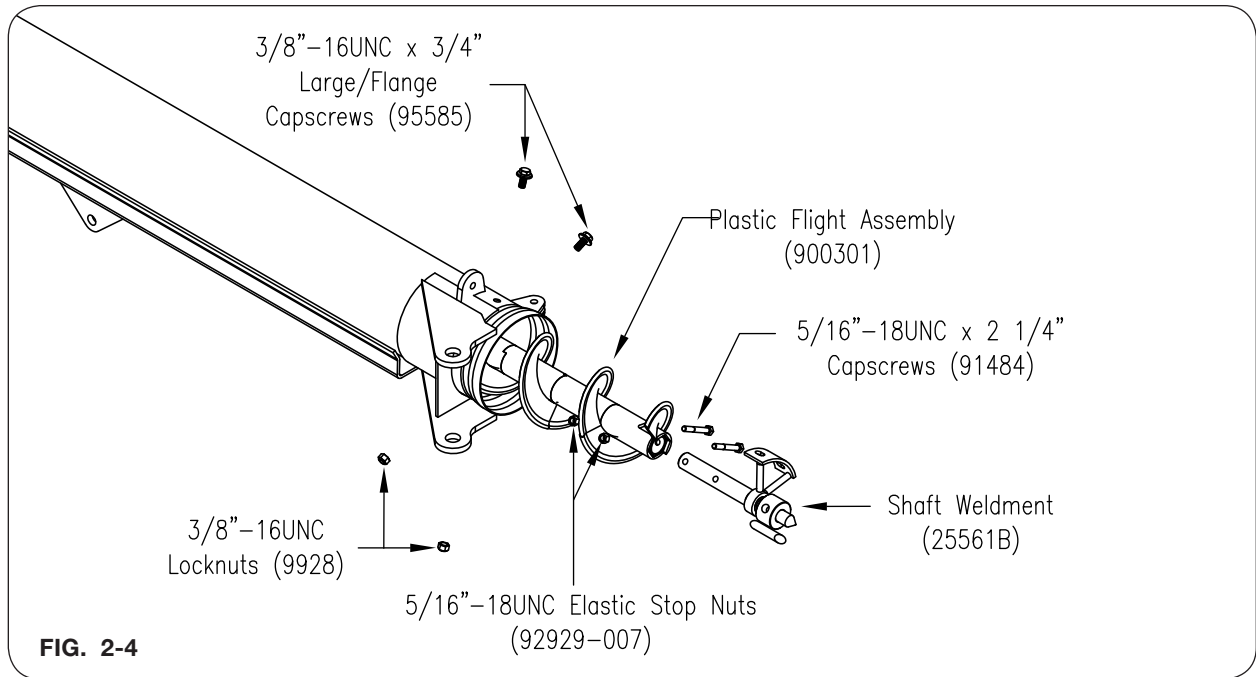

- 4B. Remove the two 5/16"-18UNC x 2 1/4" capscrews (91484) and 5/16"-18UNC elastic stop nuts (92929-007) from the end of the upper plastic flighting and insert the drive coupler weldment (23885). Secure into position with the previously removed capscrews and elastic stop nuts. See FIG. 2-5.

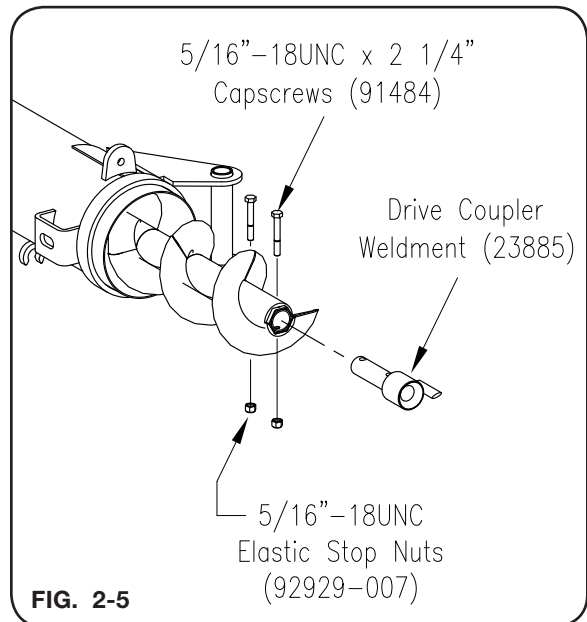

## Auger Assembly (Continued)

### Brush, Steel & Plastic Flightings

5. On the spout end of the fill auger, remove end cap (2865B) by removing self-drilling screws (9512). Also, remove the 3/8"-16UNC x 1 3/4" capscrew (9390-058) and 3/8"-16UNC locknut (9928) from the hydraulic motor (91604B). Retain all hardware removed. See FIG. 2-6.

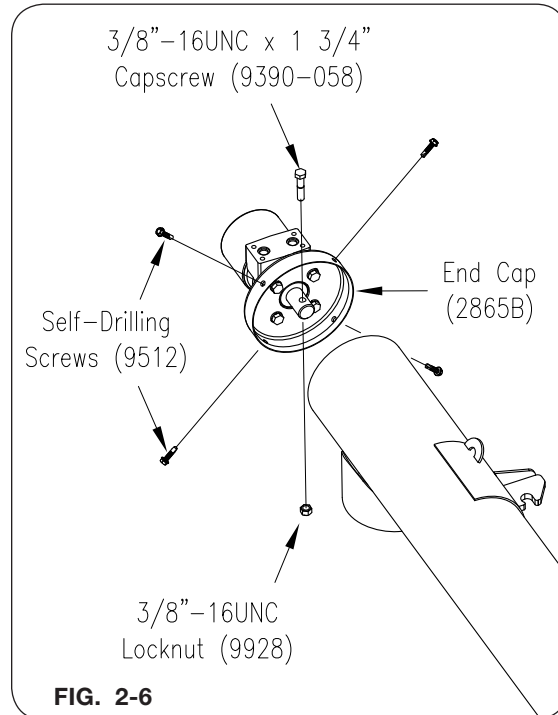

6. Attach the flighting to the hydraulic motor (91604B) with the 3/8"-16UNC x 1 3/4" capscrew (9390-058) and 3/8"-16UNC locknut (9928) previously removed (FIG. 2-7).

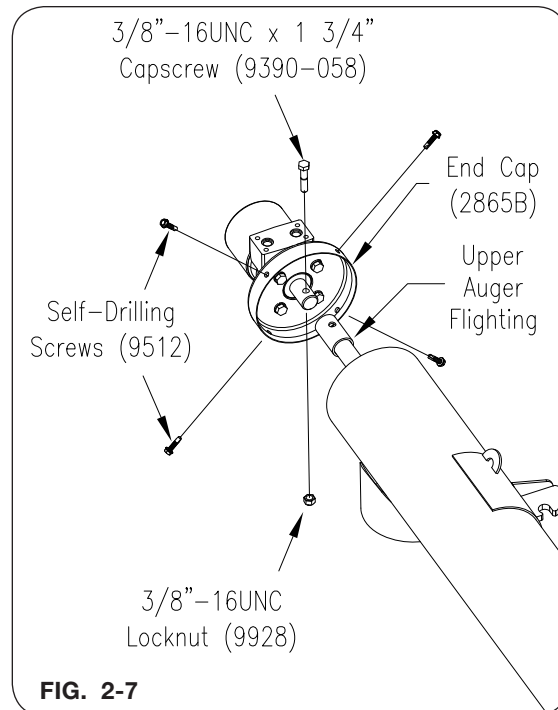

## Auger Assembly (Continued)

7. Assemble the upper and lower auger together using the 7/8" Dia. x 7 7/8" pin (23975) and two 7/8"-14UNF thin locknuts (96976-036) (FIG. 2-8). Tighten according to "Torque Chart".

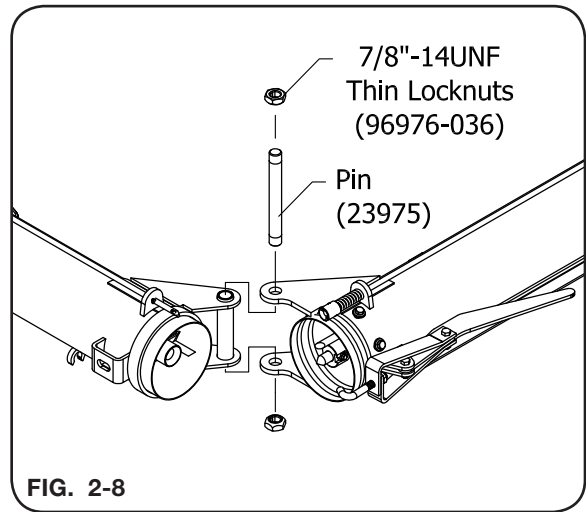

8. Latch both halves together (FIG. 2-9).

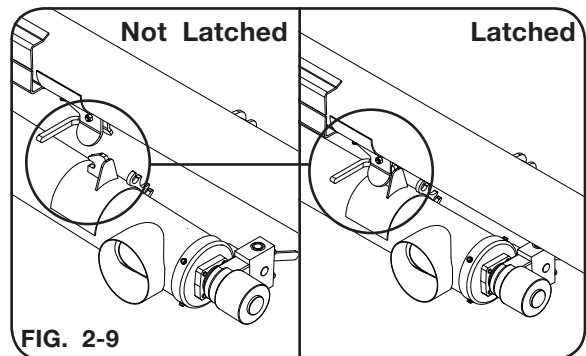

9. Loosely assemble the back hopper panel (108020B) to the lower auger using 5/16"-18UNC x 3/4" flange screws (91256) and 5/16"-18UNC large flange hex nuts (91257) (FIG. 2-10).

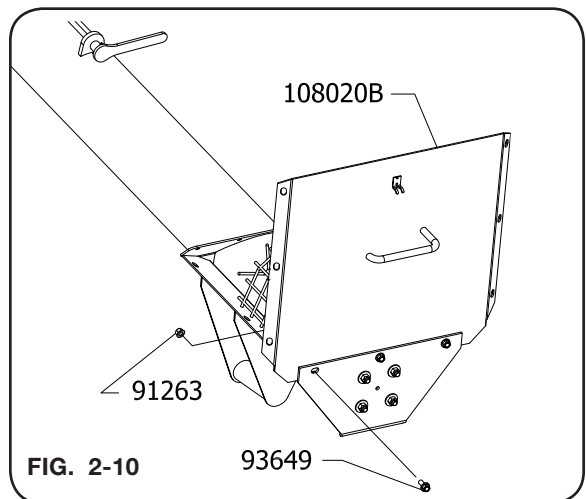

## Auger Assembly (Continued)

- Loosely assemble the hopper side panels (23150B & 23151B) to the lower auger and the back hopper panel using 5/16"-18UNC x 3/4" flange screws (91256) and 5/16"-18UNC large flange hex nuts (91257 (FIG. 2-11).
- Tighten the hopper panel hardware according to "Torque Chart".

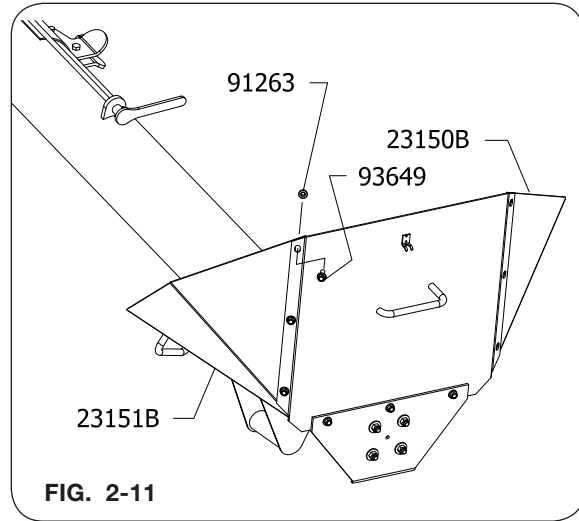

- Attach the hopper seal (108021) to the lid weldment (23661B) using plate (23270B), 1/4"-20UNC x 5/8" capscrews (9390-002), 1/4" SAE flat washers (9405-062), and 1/4"-20UNC locknuts (9936) (FIG. 2-12 & FIG. 2-13).
- Attach the other end of the hopper seal (108021) to the lower auger using plate (23271B), 1/4"-20UNC x 5/8" capscrews (9390-002), 1/4" SAE flat washers (9405-062), and 1/4"-20UNC locknuts (9936) (FIG. 2-12 & FIG. 2-13).

**NOTE:** If the hopper lid does not fit properly, adjust the side hopper panels accordingly. Retighten hardware according to "Torque Chart".

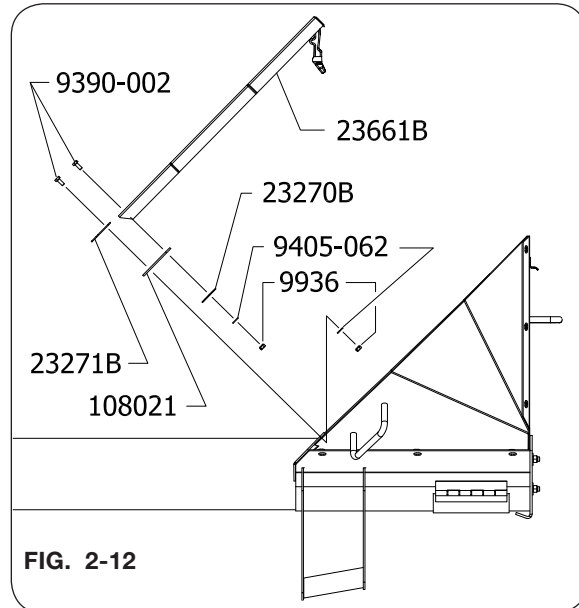

## Auger Assembly (Continued)

15. Install fluorescent orange decal (9003125) and red reflector (9003126) to the extreme left-hand side of the hopper. Be sure that reflectors are clearly visible when looking at rear of unit. (FIG. 2-14)

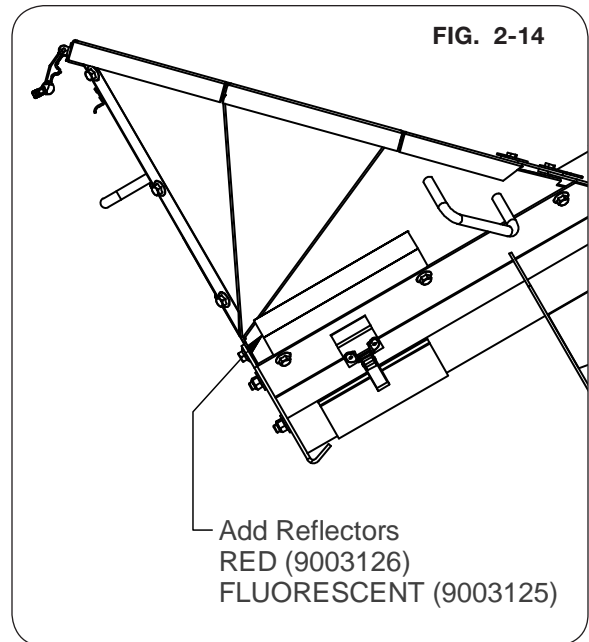

16. Assemble the pivot tube weldment (23452B) to the lower auger. Insert the tube (23523) into the pivot weldment (23452B) and secure it to the lower auger with capscrew 5/8"-11UNC x 5 1/2" (9390-135) and 5/8"-11UNC locknut (9801) (FIG. 2-15). Tighten hardware according to "Torque Chart".

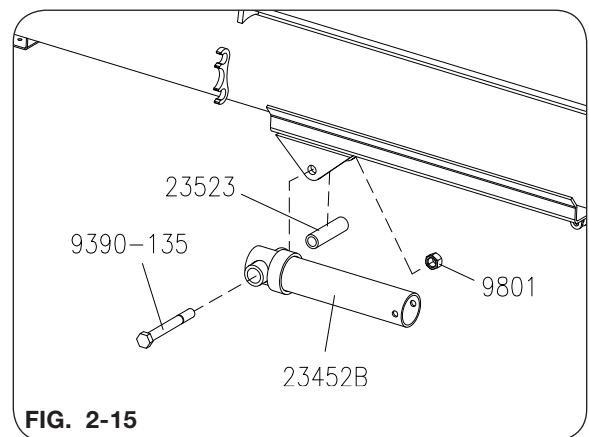

## Mounting Brackets and Support Stand

### CAUTION

- DO NOT USE REAR PLATFORM BEFORE REPLACEMENT RAILING IS INSTALLED. FAILURE TO DO SO COULD LEAD TO FALLING, CAUSING DAMAGE OR SERIOUS PERSONAL INJURY.

Case IH 500T & New Holland P2085 Drills require replacement of the right-hand side safety railing prior to installation of the drill fill.

1. Attach the WARNING decal (9501891) above the drill ladder and to the platform. (FIG. 2-16)

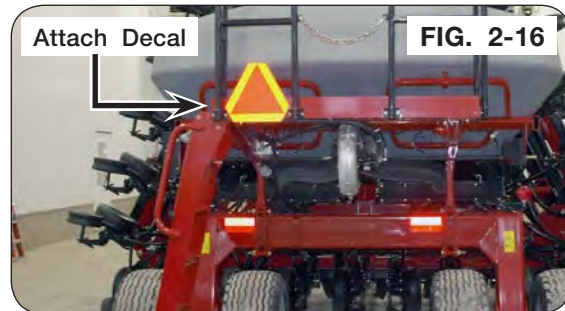

2. Remove and save the right-hand side railing and mounting hardware from the drill platform on the rear of the drill. (FIG. 2-17)



3. Fold over the new right-hand side railing and pin it together. (FIG. 2-18)

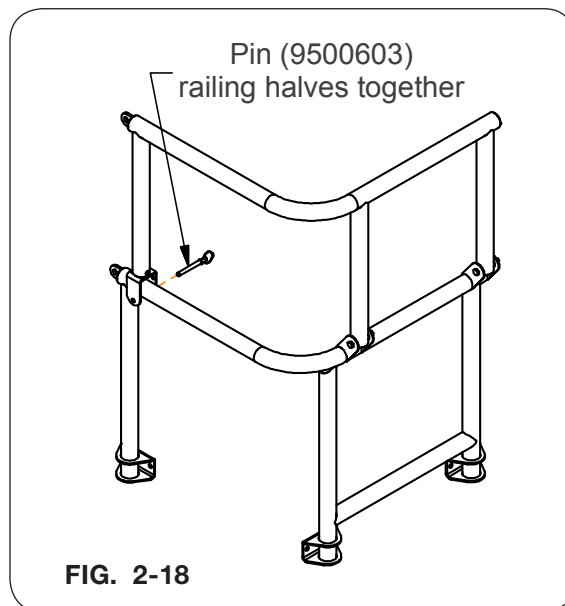



## Mounting Brackets and Support Stand (continued)

4. Install provided replacement railing with previously removed hardware (FIG. 2-19). Attach the previously removed railing chain.



5. Remove and save the self tapping screws from the rear frame that hold the electrical line in place. (FIG. 2-20 and FIG. 2-21)

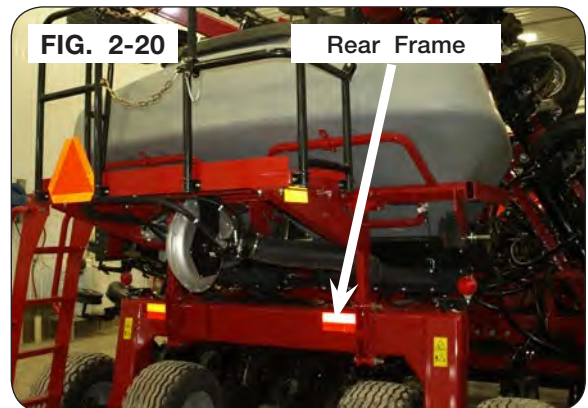

## Mounting Brackets and Support Stand (continued)

6. With a minimum safe lifting device rated for 200 lbs., lift the right-hand main arm weldment (2004136B) (FIG. 2-22).

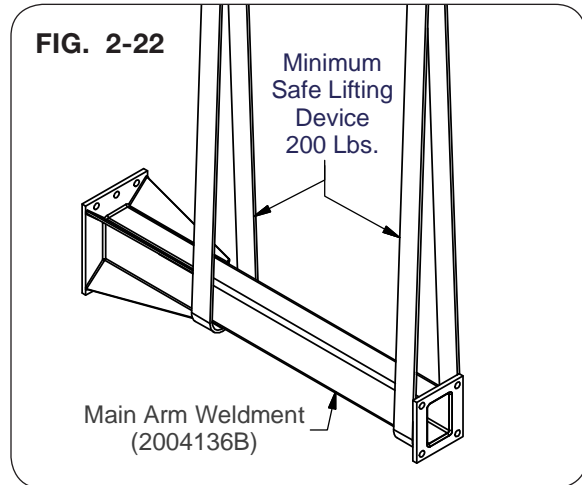

7. Locate the drill's right-hand vertical tank support tube. Position the auger right-hand main arm weldment (2004136B) 11.5" to the left as shown in (FIG. 2-23 & FIG. 2-24).

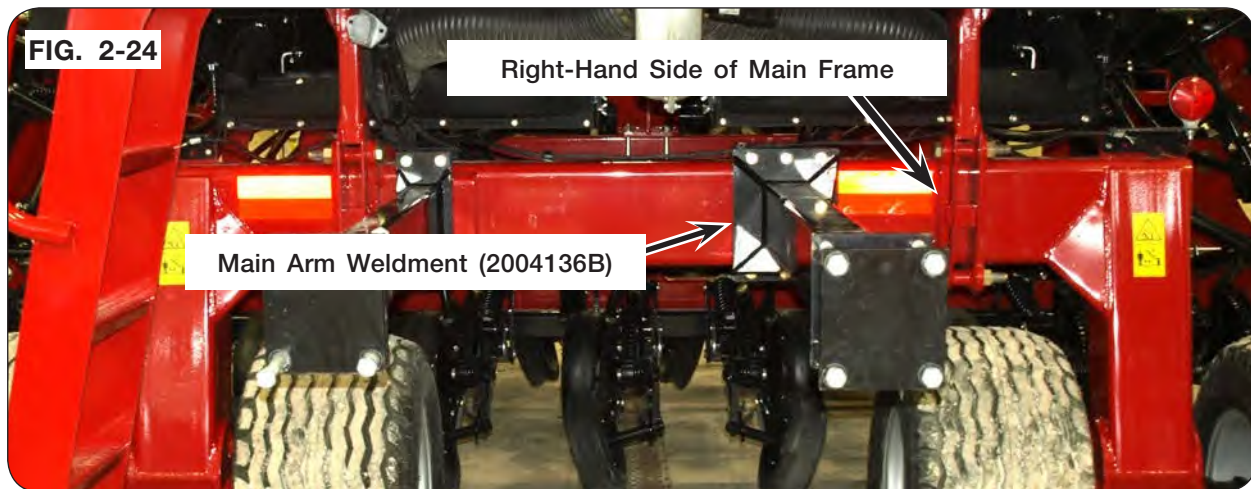
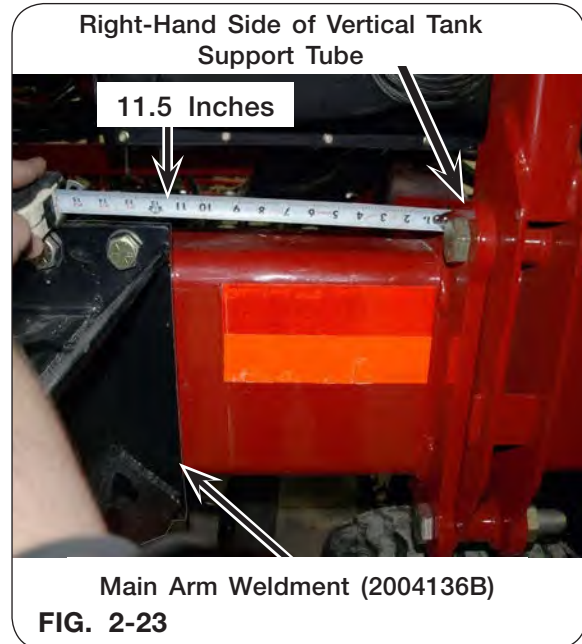

## Mounting Brackets and Support Stand (continued)

- Loosely assemble the main arm weldment (2004136B) to the left-side of the main frame with two angles (2004151B), six 3/4"-10UNC x 8" capscrews (91299-161), and six 3/4"-10UNC locknuts (9802) (FIG. 2-25). Align the angles (2004151B) and secure with two 3/4"-10UNC x 10" capscrews (91299-257), and 3/4"-10UNC locknuts (9802) (FIG. 2-25).

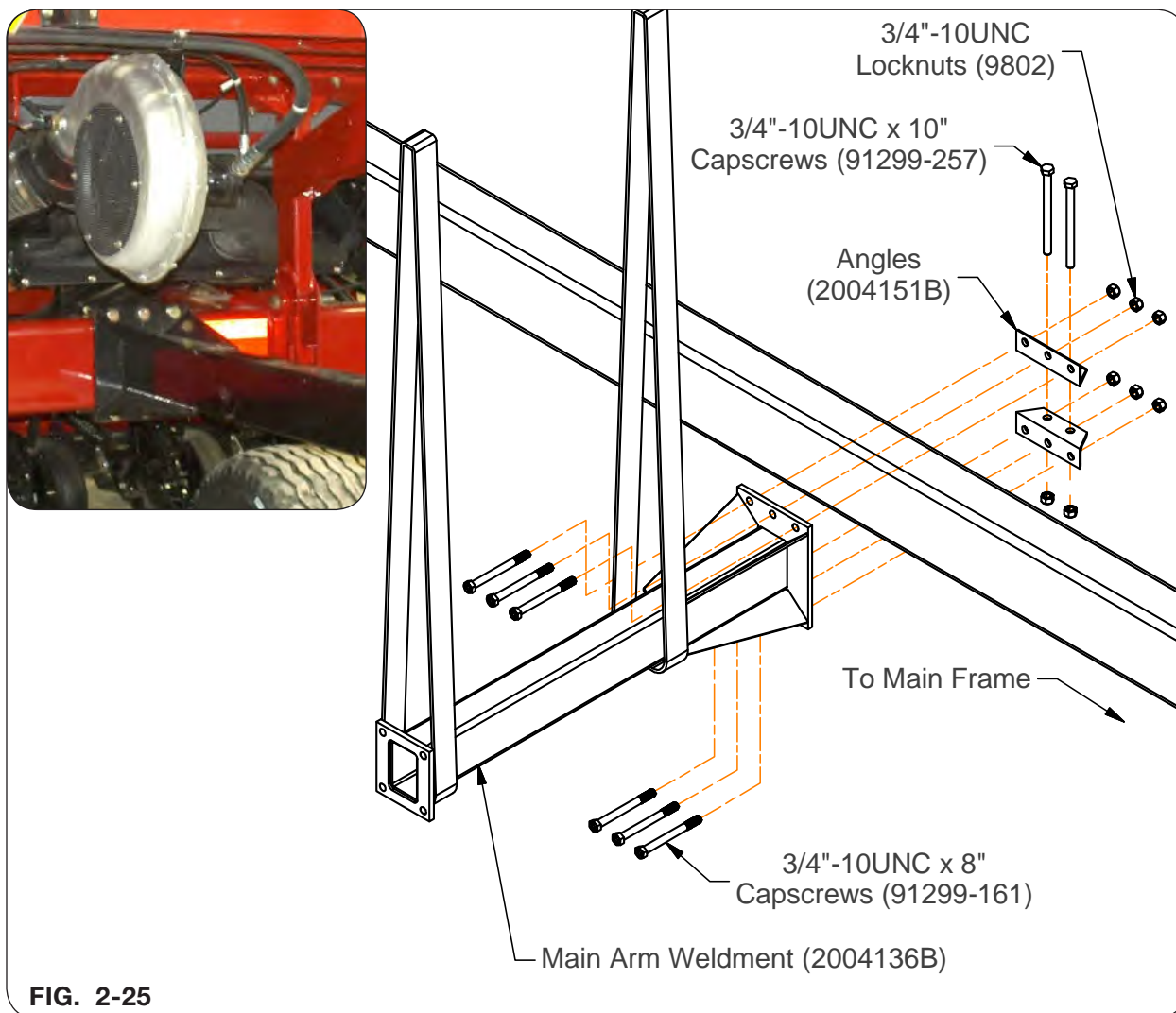

- Tighten all hardware evenly and insure all bolts and brackets are straight. (FIG. 2-25)
- Loosely install backing plate (2004154B) to the end of the main arm weldment (2004136B) with four 3/4"-10UNC x 6 1/2" capscrews (91299-158) and 3/4"-10UNC locknuts (9802) (FIG. 2-26).

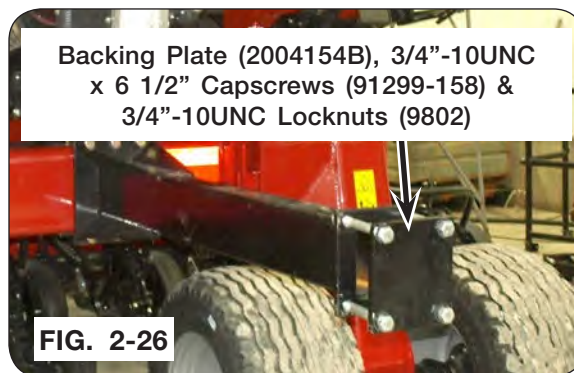

## Mounting Brackets and Support Stand (continued)

11. With a minimum safe lifting device rated for 200 lbs., lift the transport arm weldment (2004139B) (FIG. 2-27).

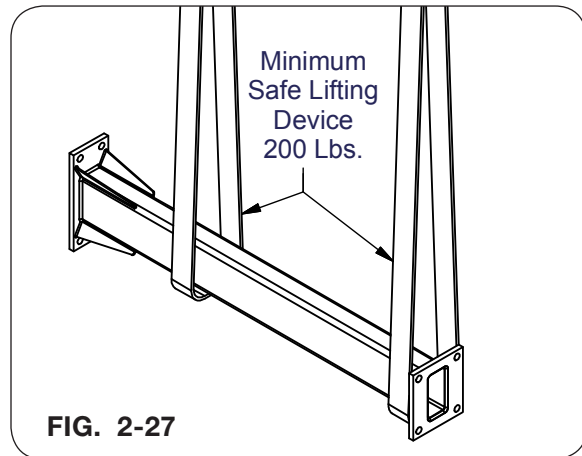

12. The left-hand transport arm weldment (2004139B) has five bolts and should be located 1.75 inches to the right of the left-hand tank support. (FIG. 2-28 & FIG. 2-29)

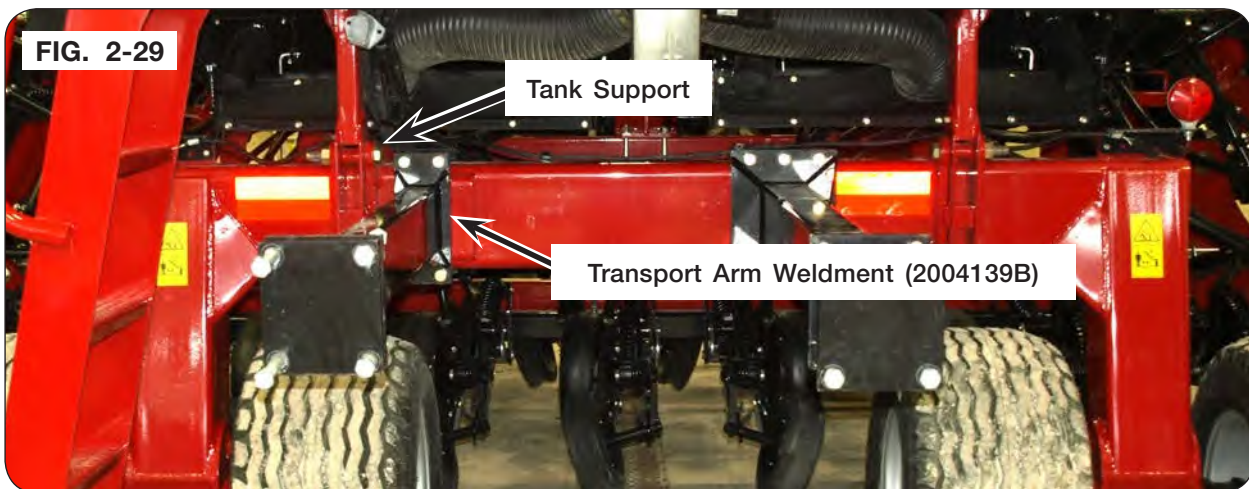

## Mounting Brackets and Support Stand (continued)

- Loosely assemble the transport arm weldment (2004139B) to the right-side of the tank support with two angles (2004152B), four 3/4"-10UNC x 8" capscrews (91299-161), and four 3/4"-10UNC locknuts (9802) (FIG. 2-30). Align the angles (2004152B) and secure with a 3/4"-10UNC x 10" capscrew (91299-257), and 3/4"-10UNC locknut (9802) (FIG. 2-30).

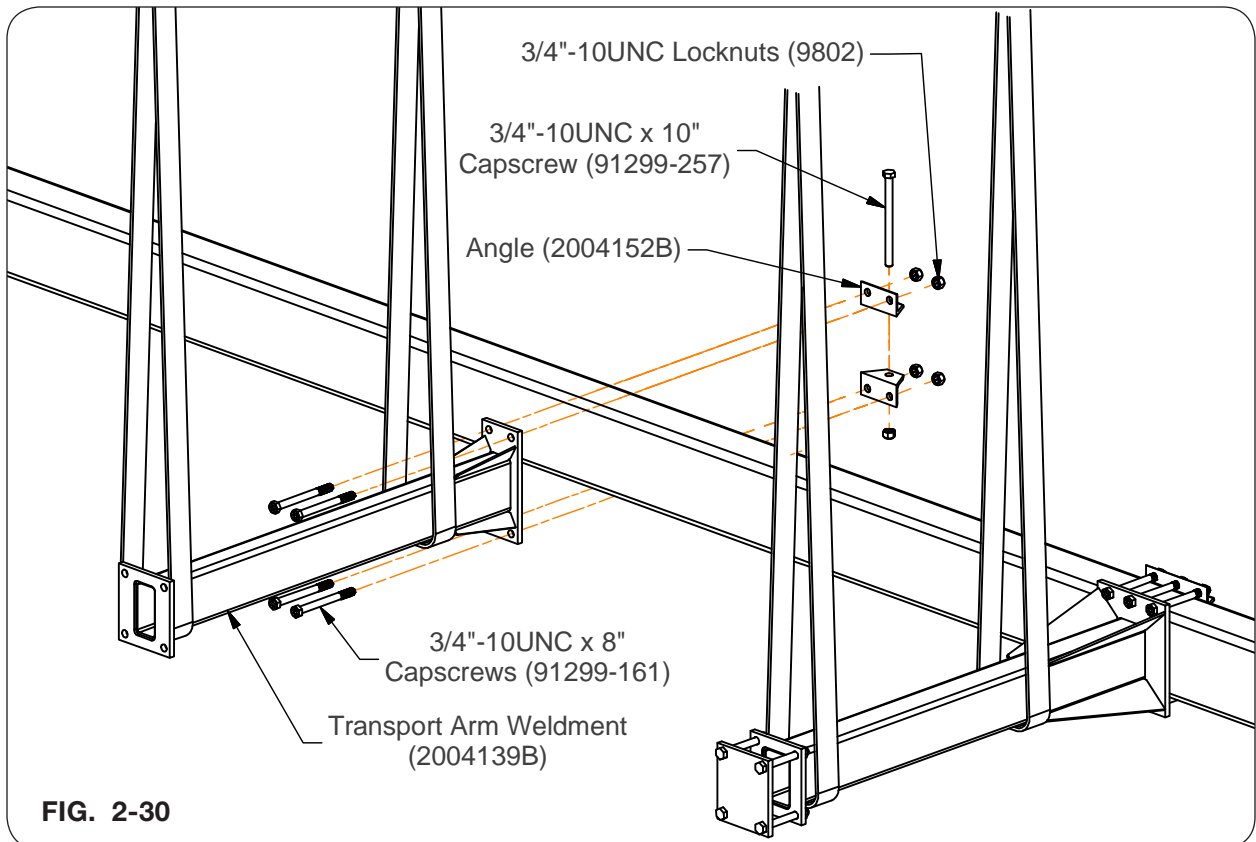

- Tighten all hardware evenly and insure all bolts and brackets are straight. (FIG. 2-30)
- Loosely install backing plate (2004154B) to the end of the main arm weldment (2004136B) with four 3/4"-10UNC x 6 1/2" capscrews (91299-158) and 3/4"-10UNC locknuts (9802) (FIG. 2-31).

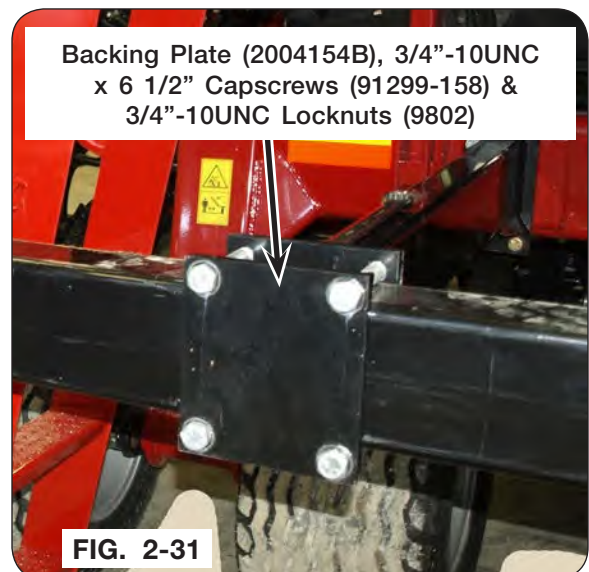

## Mounting Brackets and Support Stand (continued)

16. With a minimum safe lifting device rated for 100 lbs., assemble the cross tube weldment (2004144B) to the main arm weldment (2004136B) and transport arm weldment (2004139B). The cross tube weldment (2004144B) should be located 16.5 inches from the right-hand side of the main arm weldment (2004136B) (FIG. 2-32 & FIG. 2-33). Tighten backing plates (2004154B) with the 3/4"-10UNC x 6 1/2" capscrews (91299-158) and 3/4"-10UNC locknuts (9802). (FIG. 2-32 & FIG. 2-33)

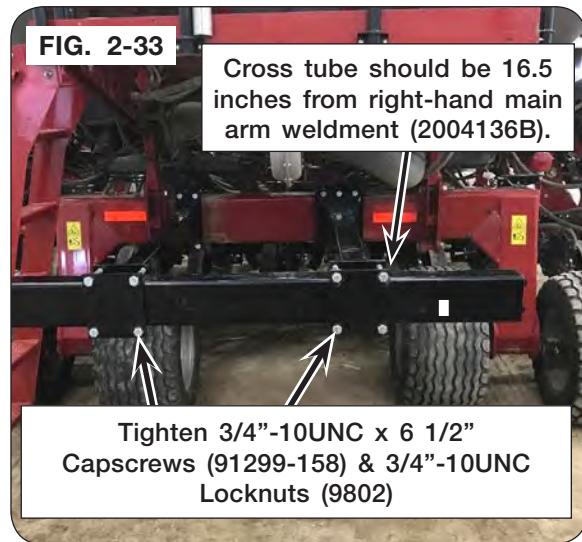

## Mounting Brackets and Support Stand (continued)

17. With a minimum safe lifting device rated for 50 lbs., position the vertical post assembly (2004146B) on top of cross tube (2004144B) and 5 inches from the right-hand side of the main arm weldment (2004136B) (FIG. 2-34). Loosely mount to the cross tube weldment (2004144B) with 6 3/4" x 8 1/2" plate (2004150B), four 3/4"-10UNC x 9" capscrews (9390-449), and four 3/4"-10UNC locknuts (9802) (FIG. 2-34). When the vertical post assembly arm is swung completely to the left, the post should be centered.

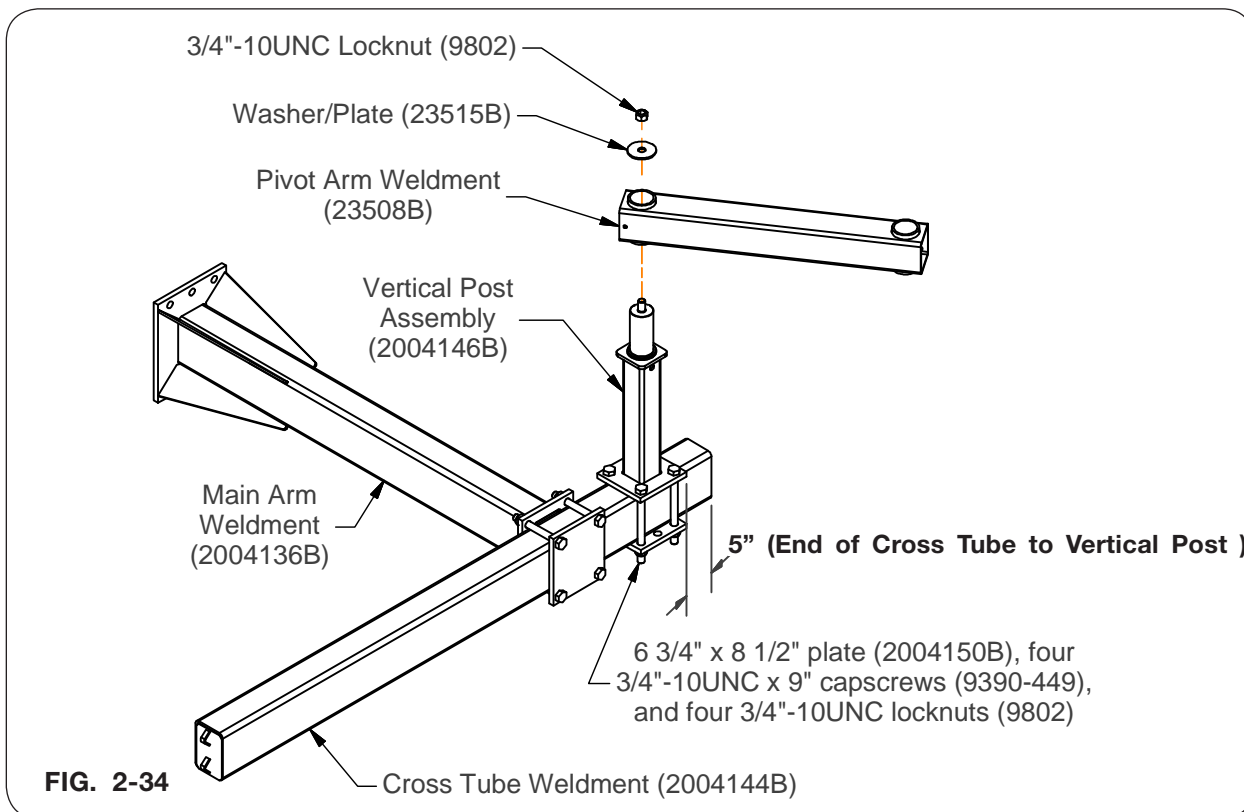

18. With a minimum safe lifting device rated for 50 lbs., loosely mount the pivot arm weldment (23508B) to the vertical post assembly (2004146B) with washer/plate (23515B) and 3/4"-10UNC locknut (9802). (FIG. 2-34)
19. Tighten all hardware as recommended in the "Torque Chart" located in the MAINTENANCE section.

## Mounting Brackets and Support Stand (continued)

20. Locate the transport bracket mounting tube (2005106B) at the end of the cross tube weldment (2004144B) (FIG. 2-35). Loosely attach transport bracket mounting tube (2005106B) to the cross tube weldment (2004144B) with 6 3/4" x 8 1/2" plate (2004150B), 3/4"-10UNC x 6 1/2" capscrews (91299-158), and 3/4"-10UNC locknuts (9802) (FIG. 2-36).
21. Tighten all hardware as recommended in the "Torque Chart" located in the MAINTENANCE section.

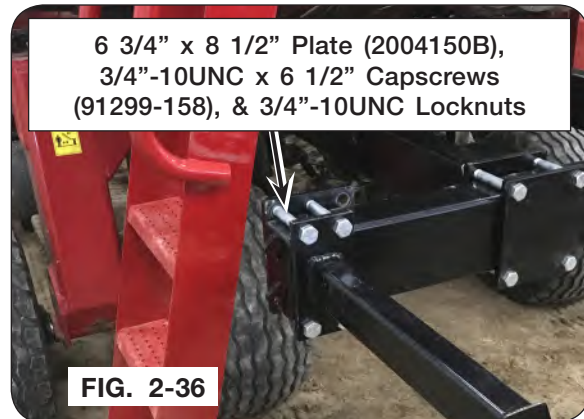
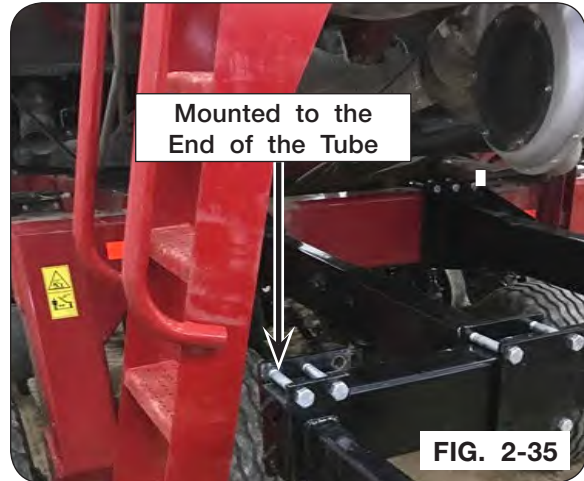



## Mounting Brackets and Support Stand (continued)

22. Mount the transport bracket assembly (2005119B) to the end of the transport bracket mounting tube (2005106B) (FIG. 2-37).

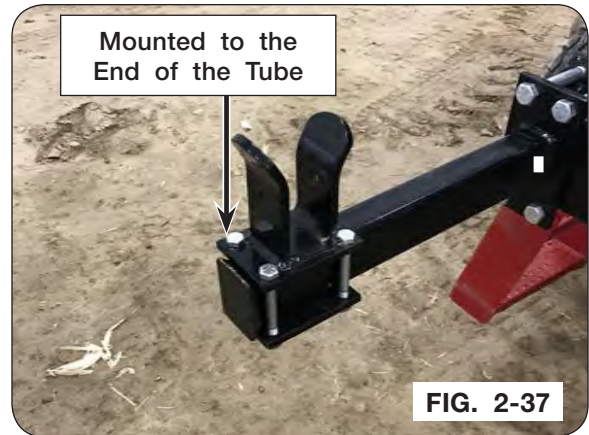

23. Loosely attach the transport bracket assembly (2005119B) to the transport bracket mounting tube (2005106B) with 3 3/4" x 5 1/4" plate (2005113B), 1/2"-13UNC x 4 1/2" capscrews (9390-112), and 1/2"-13UNC locknuts (9800) (FIG. 2-38).

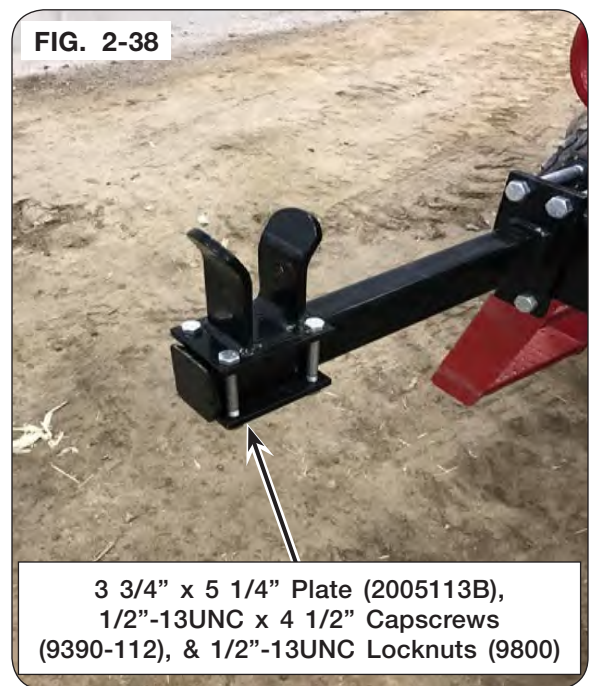

24. Tighten all hardware as recommended in the "Torque Chart" located in the MAINTENANCE section.
25. Zip tie electrical lines underneath the frame to match their original routing.

## Attaching The Auger

1. Using a safe lifting devices rated at 500 lbs. minimum, lift the auger assembly into the mounting position as shown in FIG. 2-39.

FIG. 2-39

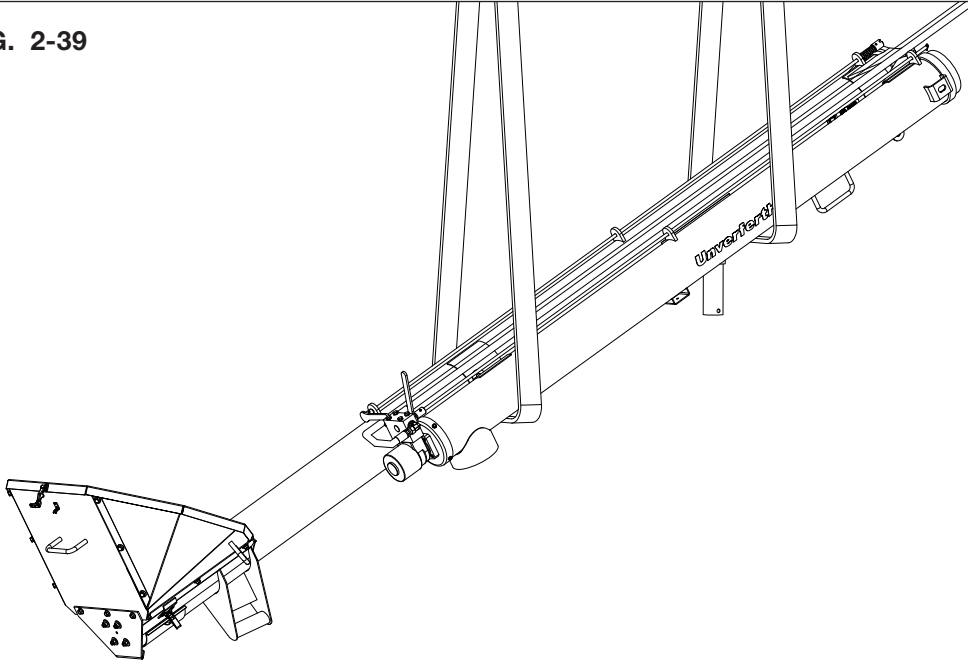

2. Insert the pivot tube weldment (23452B) on the auger assembly into the pivot arm weldment (23508B). (FIG 2-39)
3. Attach collar (22409B) to the bottom of the pivot tube weldment (23452B) with 3/8"-16UNC x 3 1/2" capscrew (93990-065) and 3/8"-16UNC locknut (9928). (FIG. 2-40)

FIG. 2-40

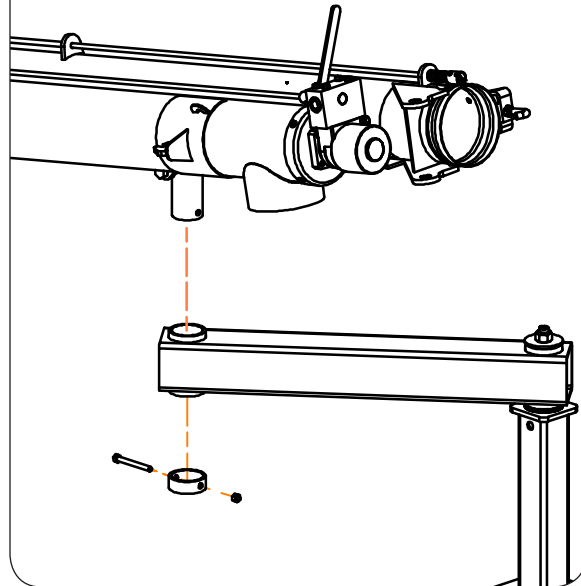

## Hydraulics

### **⚠ WARNING**

- HYDRAULIC SYSTEM MUST BE PURGED OF AIR BEFORE OPERATING TO PREVENT SERIOUS INJURY OR DEATH.
- HIGH-PRESSURE FLUIDS CAN PENETRATE THE SKIN AND CAUSE SERIOUS INJURY OR DEATH. SEEK MEDICAL TREATMENT IMMEDIATELY IF INJURED BY HIGH-PRESSURE FLUIDS. USE CARDBOARD OR WOOD TO DETECT LEAKS IN THE HYDRAULIC SYSTEM.
- RELIEVE HYDRAULIC PRESSURE BEFORE SERVICING HYDRAULIC SYSTEM. SEE TRACTOR AND DRILL OPERATOR'S MANUALS FOR PROPER PROCEDURE.
- EYE PROTECTION AND OTHER APPROPRIATE PERSONAL PROTECTIVE EQUIPMENT MUST BE WORN WHILE SERVICING IMPLEMENT.

Be sure that the hoses do not rub any sharp surfaces or are kinked in any way.

Hoses are provided to the remote outlets on the drill. If outlets are not present, contact your Case or New Holland dealer for optional package, or provide additional hose lengths to reach the tractor.

Unverferth recommends that tying into drill hydraulics should only be done with Case or New Holland remote outlet accessory kit.

1. Remove the cap plugs from the valve (99933) and insert the 90° elbows (9863) (FIG. 2-41).
2. Attach the 1/2" x 185" hoses (95964) to the 90° elbows (9863) (FIG. 3-40). Route the 1/2" x 185" hoses (95964) as shown and attach the hoses using cable ties and the hose retainers.

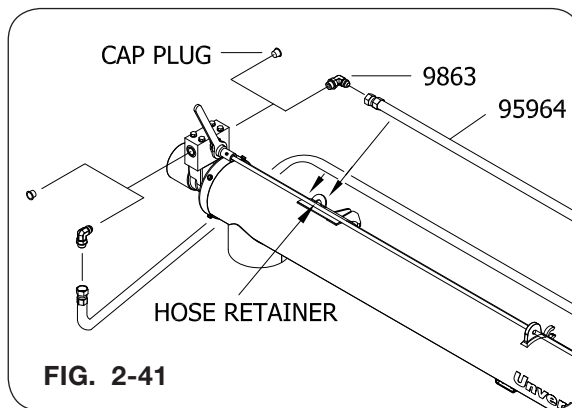

## Hydraulics (continued)

3. Attach the 1/2" x 102" hoses (9882) to the end of the 1/2" x 185" hoses (95964). Route hoses as shown and secure using cable ties provided.
4. Attach the adapters (9864) to the opposite ends of the hoses (9882).
5. Be certain clearance to rafters, walls, machinery, etc. exists before unfolding auger. With a tractor hooked to the unit, activate the flighting to make sure everything moves freely. Do not pinch or kink hoses.
6. Check for and correct any leaks. Make sure hoses are not kinked, stretched, or twisted. Secure hoses to prevent cuts or chafing during operation.

FIG. 2-42



FIG. 2-43

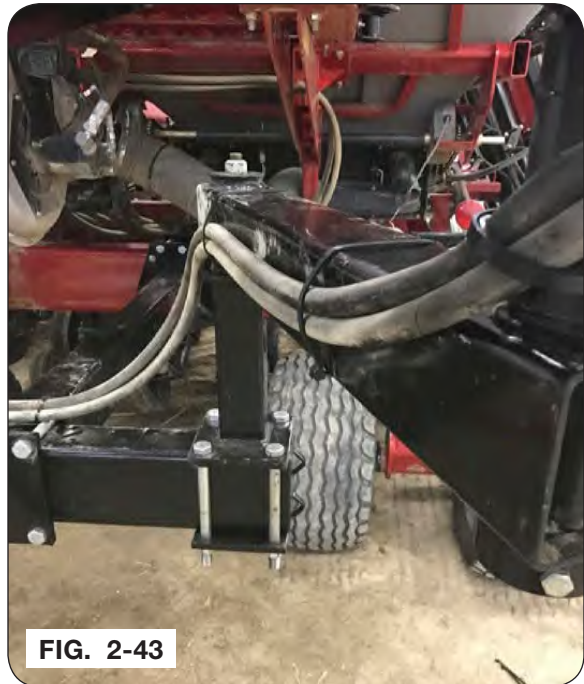
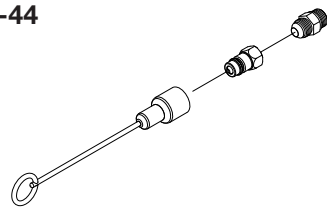

FIG. 2-44



## Spout Assembly

1. Attach the spout (97094) to the upper auger using clamp (98060). Slide the spout on until it connects with the main auger and secure (FIG. 2-45).



2. Attach the strap (108088) to the upper auger assembly using 1/4"-20UNC x 5/8" capscrew (9390-002) and locknut (9936) (FIG. 2-46). Retain telescopic spout assembly into transport position by separating the two velcro straps (108088) and looping one strap through the nylon handle on the spout. Wrap the strap around the spout and velcro the strap ends together as shown in FIG. 2-47.

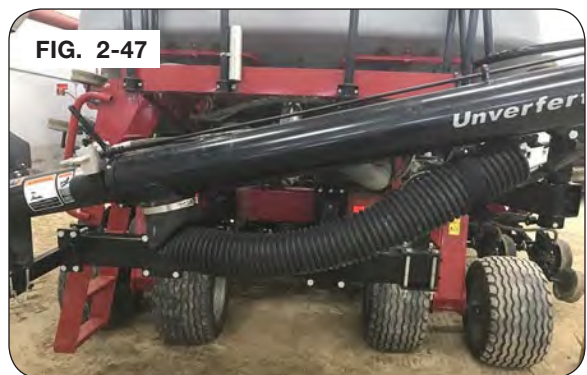
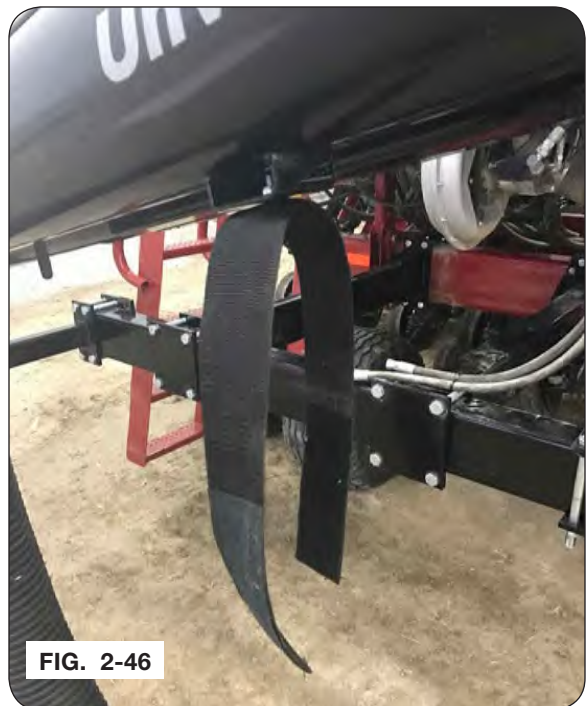

## Hydraulic Flow Control Installation (Optional)

Tractors having high-capacity hydraulic systems with 12 to 20 GPM flow, may cause your conveyor or auger to run too fast, resulting in:

- A. Excess Vibration
- B. Excess Wear
- C. Loss of Performance

To eliminate these problems, an adjustable flow control valve is offered for installation into the auger/conveyor hydraulic system. This valve will allow the operator to adjust the flow to obtain the proper speed for your application.

**NOTE:** The speed control valve may be ordered through your Unverferth dealer.

### **⚠ WARNING**

- RELIEVE THE HYDRAULIC SYSTEM OF ALL PRESSURE BEFORE ADJUSTING OR SERVICING. SEE THE HYDRAULIC POWER UNIT OPERATOR'S MANUAL FOR PROPER PROCEDURES.
- EYE PROTECTION AND OTHER APPROPRIATE PERSONAL PROTECTIVE EQUIPMENT MUST BE WORN WHILE SERVICING IMPLEMENT.
- HIGH-PRESSURE FLUIDS CAN PENETRATE THE SKIN AND CAUSE SERIOUS INJURY OR DEATH. SEEK MEDICAL TREATMENT IMMEDIATELY IF INJURED BY HIGH-PRESSURE FLUIDS. USE CARDBOARD OR WOOD TO DETECT LEAKS IN THE HYDRAULIC SYSTEM.

### **CLOSED CENTER SYSTEM**

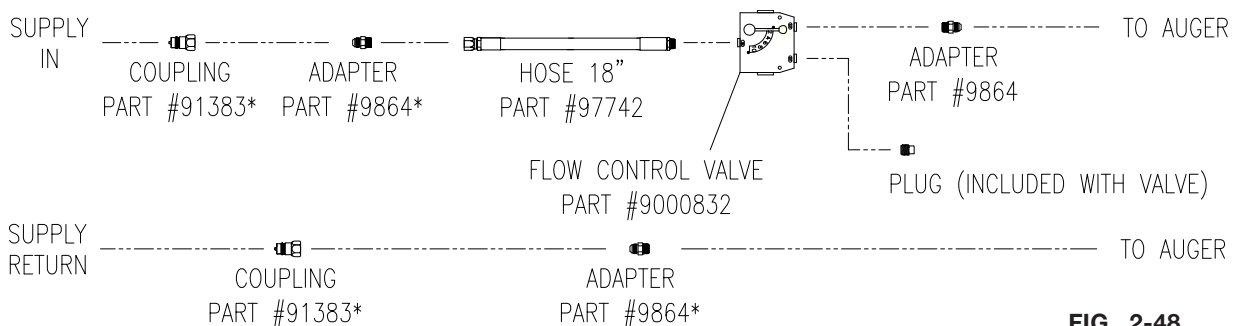

**FIG. 2-48**

\* Parts are included with auger/conveyor.

1. Mount valve and secure using two 1/4" bolts and locknuts provided.
2. Install handle onto valve as shown.
3. Once the control valve is installed, the auger/conveyor speed can be set as follows:
  - A. Set flow control valve approximately 1/2 way on flow indicator (lock into position).
  - B. Start oil flow and run auger/conveyor to check speed. Flighting/belt should run smooth, not lag or fluctuate in speed, adjust speed control valve if necessary.

**NOTE:** When auger is loaded with material, auger/conveyor should not stall. Adjust speed to allow for smooth, even feeding of material through the unit.

## Check Valve Kit Installation (Optional)

These instructions are for the installation of the Check Valve Kit (23336) for the FILL AUGER. This unit will allow the auger to only run forward.

### **⚠ WARNING**

- RELIEVE THE HYDRAULIC SYSTEM OF ALL PRESSURE BEFORE ADJUSTING OR SERVICING. SEE THE HYDRAULIC POWER UNIT OPERATOR'S MANUAL FOR PROPER PROCEDURES.
- HIGH-PRESSURE FLUIDS CAN PENETRATE THE SKIN AND CAUSE SERIOUS INJURY OR DEATH. SEEK MEDICAL TREATMENT IMMEDIATELY IF INJURED BY HIGH-PRESSURE FLUIDS. USE CARDBOARD OR WOOD TO DETECT LEAKS IN THE HYDRAULIC SYSTEM.
- TIPPING OR MOVEMENT OF THE MACHINE CAN CAUSE SERIOUS INJURY OR DEATH. BE SURE MACHINE IS SECURELY BLOCKED.

**NOTE:** Be sure to disconnect hydraulics while working in an environment clean of dirt and debris. If dirt should enter into system, flush system. Failure to remove dirt could result in motor failure or damage to system supply.

**NOTE:** The Check Valve must be installed on the return side of the motor in order to work properly.

1. Relieve hydraulic pressure and disconnect hydraulic RETURN line from the control valve.
2. Disconnect the quick coupler adapter assembly from the RETURN line (FIG. 2-49).

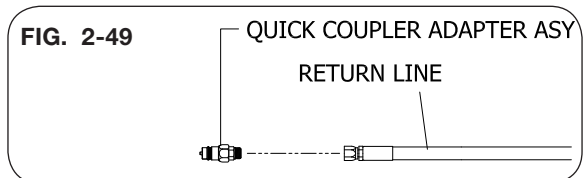

3. Assemble the check valve (97740), adapter (96935), and adapter (9864) as shown in FIG. 2-50.

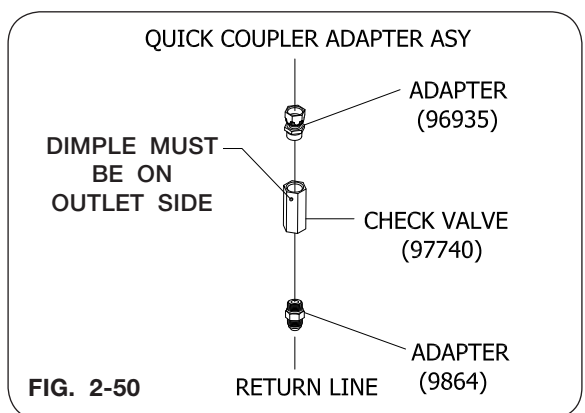

4. Insert the check valve assembly between the quick coupler adapter assembly and the RETURN line (FIG. 2-51).
5. Check auger for proper rotation before loading with material.

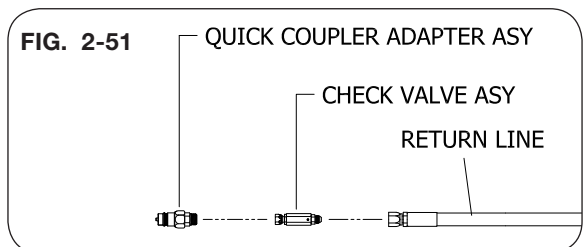

**Notes**



**SECTION III  
Operation**

Preparing Drill ..... 3-2  
Operating Procedures ..... 3-2  
Transporting ..... 3-5  
Hydraulic System ..... 3-6

## Preparing Drill

### **⚠ WARNING**

- **KNOW AND UNDERSTAND SAFETY RULES BEFORE OPERATING OR SERVICING THIS MACHINE. REVIEW “SAFETY” SECTION IN THIS MANUAL IF NECESSARY.**

Read this operation section thoroughly. Acquaint yourself with the adjustments required to obtain efficient and trouble-free operations.

### **IMPORTANT**

- *Before attempting to attach the drill to the tractor, familiarize yourself with operations and adjustments of the unit. To insure safe operating conditions, obey all safety notes outlined in the drill's operator's manual.*

## Operating Procedures

### **⚠ WARNING**

- **SEED MAY BE TREATED WITH HAZARDOUS MATERIAL. AVOID CONTACTING SEED WITH SKIN, EYES, AND AVOID BREATHING DUST. FOLLOW MANUFACTURER'S RECOMMENDATIONS.**
- **SEED BEING TRANSPORTED MAY CONTAIN SEED TREATMENT. READ AND FOLLOW ALL REQUIREMENTS FOR PERSONAL PROTECTIVE EQUIPMENT AND FIRST AID AS OUTLINED ON SEED TAGS.**

### **⚠ CAUTION**

- **KEEP ALL UNAUTHORIZED PEOPLE CLEAR OF WORK AREA.**

1. Pull tractor and planter into position, shift tractor into park (or neutral) and lock brakes on tractor. Planter must be lowered to the ground to fill.
2. Open the lid on the planter tanks to allow the fill auger to be positioned.
3. Release the latch handle on the FILL auger (FIG. 3-1), and unfold the two auger halves.

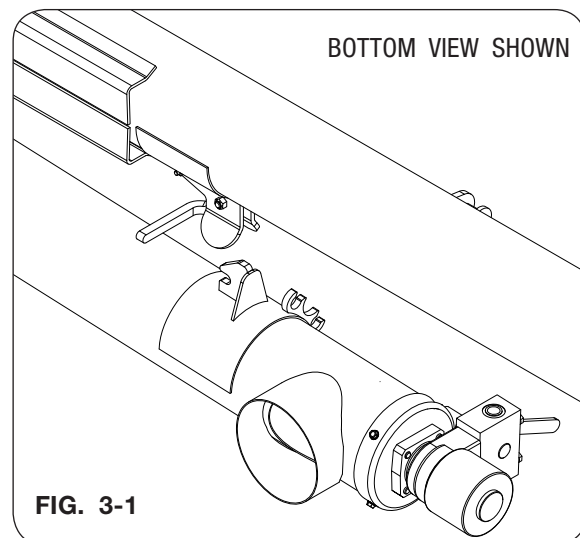
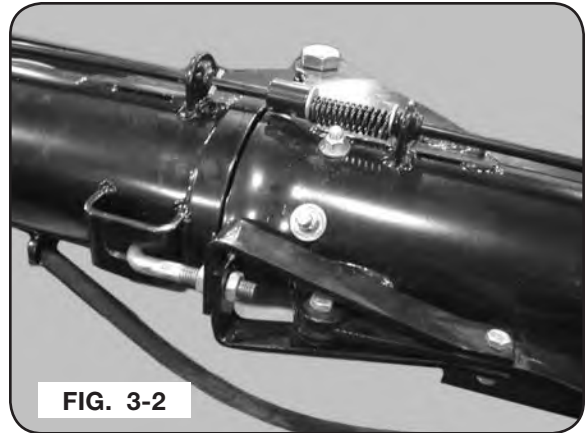

FIG. 3-1

## Operating Procedures (Continued)

4. Latch the upper and lower augers together as shown in FIG. 3-2.



### **WARNING**

- THE AUGER HALVES MUST BE LOCKED INTO POSITION BEFORE SWINGING THE AUGER INTO THE OPERATING POSITION. FAILURE TO DO SO WILL DAMAGE THE AUGER OR CAUSE PERSONAL INJURY.

5. Remove the hitch pin (99697) from the transport bracket as shown in Fig. 3-3.

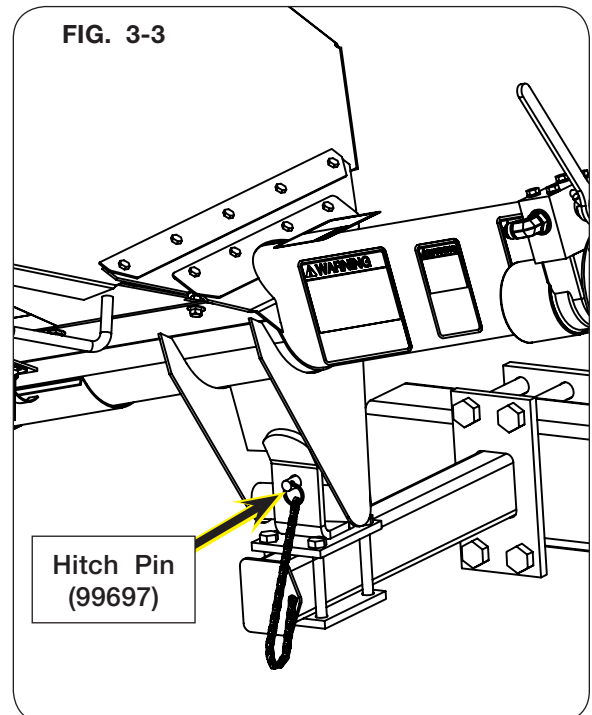

## Operating Procedures (continued)

### **⚠ WARNING**

- **FALLING CAN CAUSE SERIOUS INJURY OR DEATH. SECURE RAILING AND CHAINS INTO WORKING POSITION.**

6. Railing will need to be opened by utilizing folding mechanism located on RH side railing. Hook top support chain and remove pins holding top portion of railing in place. Carefully lowering railing to allow auger access to center fill.
7. Swing auger into operating position as shown in FIG. 3-4.



7. Engage the tractor hydraulic system to allow the hydraulic oil to flow to the auger. Make sure the auger flighting is rotating in a forward direction. If flighting is rotating in a backward direction, either reverse the hoses going into the tractor or move the tractor control hydraulic lever in the opposite direction to reverse the flow.
8. Start the auger flighting moving and begin the flow of seed into the auger tube. Adjust the seed flow for a smooth, even flow of seed through the auger tube.
9. Fill the tank evenly by moving the adjustable spout from side-to-side while the auger is running. When the desired level is reached in the tank(s), close the transfer wagon door and empty out the auger.

## Transporting

1. Place the auger back in the transport bracket. Insert the hitch pin to keep the auger in place.

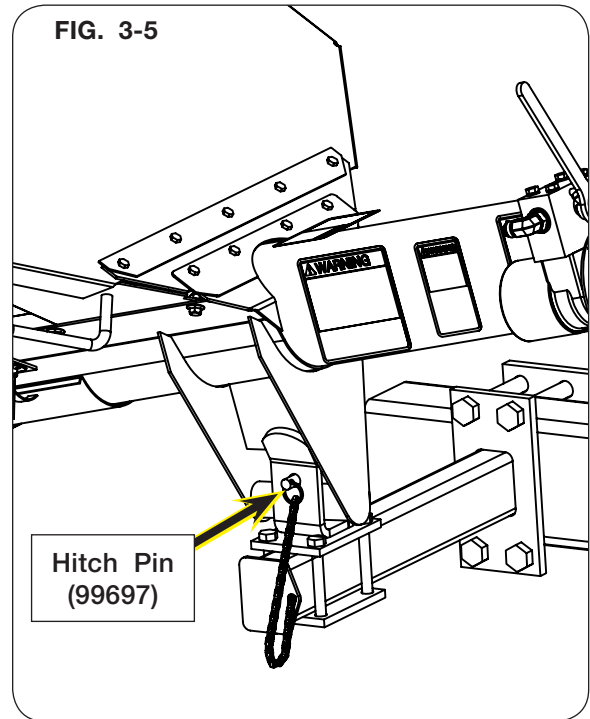

2. Unlatch the two auger halves and swing the upper auger back into transport position as shown in FIG. 3-6.



3. Secure the two auger halves together with the latch handle FIG. 3-7.

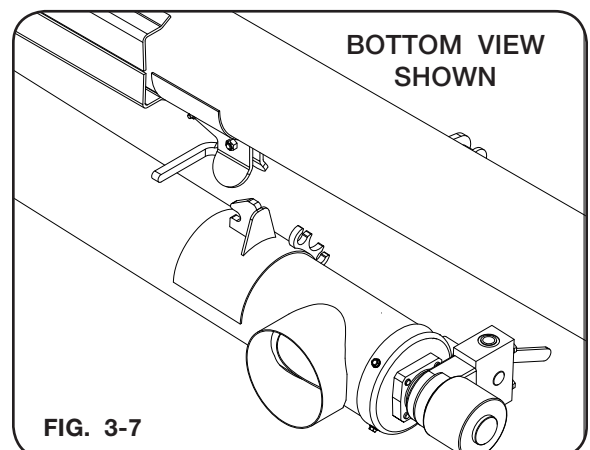

### Transporting (continued)

4. Separate the two velcro straps (108088) and loop one strap through the nylon handle on the spout. Wrap the strap around the spout and velcro the strap ends together as shown in FIG. 3-8.



### IMPORTANT

- Always fold the fill auger when not filling the planter.

### Hydraulics

#### **⚠ WARNING**

- HIGH-PRESSURE FLUIDS CAN PENETRATE THE SKIN AND CAUSE SERIOUS INJURY OR DEATH. SEEK MEDICAL TREATMENT IMMEDIATELY IF INJURED BY HIGH-PRESSURE FLUIDS. USE CARDBOARD OR WOOD TO DETECT LEAKS IN THE HYDRAULIC SYSTEM.
- RELIEVE THE HYDRAULIC SYSTEM OF ALL PRESSURE BEFORE ADJUSTING OR SERVICING. SEE THE HYDRAULIC POWER UNIT OPERATOR'S MANUAL FOR PROPER PROCEDURES.
- HYDRAULIC SYSTEM MUST BE PURGED OF AIR BEFORE OPERATING TO PREVENT SERIOUS INJURY OR DEATH.

## **SECTION IV Maintenance**

Lubrication.....	4-2
Miscellaneous Lube Points.....	4-2
Storage/Maintenance .....	4-2
Troubleshooting.....	4-3
Torque Chart.....	4-4
Hydraulic Fittings .....	4-5

## Drill Fill Auger — Maintenance

### Lubrication

Lubricate with an SAE multi-purpose grease. All fittings must be free from dirt and paint to insure entry of lubricant inside bearing.

### Lower Auger Bearing

Lubricate this bearing every 100 hours of operation and at the end of each season before storage. Use only one stroke of grease per bearing.



### CAUTION

- DO NOT USE A HIGH-PRESSURE GREASE GUN TO LUBRICATE THIS BEARING, AS DAMAGE TO BEARING SEAL COULD OCCUR.

**NOTE:** Excessive lubrication of this bearing will result in premature failure.

### Miscellaneous Lube Points

Oil or grease periodically (or as needed) the following:

- Hinge for clean-out door
- Swivel base on fill auger
- Latch pin housing
- Pivot bracket and arm
- Auger folding hinge and latch mechanism
- On/Off control rod

### Storage/Maintenance

Your auger is an important investment. Spend a little time to protect it from destructive rust and corrosion. You will be repaid in longer service life and better performance.

#### DO THE FOLLOWING AFTER USE:

1. Clean out auger/hopper. Use pressurized water to wash out auger and hopper after use.
2. Wipe off the following:
  - Hydraulic valve, motor, hoses, and fittings.
  - Swivel base, cradle.
  - Reflectors and warning/caution decals.
3. Check the following:
  - Mounting bolts for tightness.
  - Cable ties for tightness.
  - Valve, motor, hoses, and fittings for leaks, etc.
  - Hydraulic hoses for wear-abuse.

#### DO THE FOLLOWING BEFORE PLACING THE AUGER IN STORAGE:

- Repaint any chipped or scraped areas.
- Inspect for damaged or worn parts. Replace before next season.
- Store unit inside, away from livestock.



## Troubleshooting

SYMPTOMS	REMEDIES
<b>A. AUGER WILL NOT TURN OVER OR DEVELOP PROPER SPEED OR TORQUE:</b>	
1. Pump does not deliver sufficient pressure or volume	1. Check output and delivery, change if necessary
2. Auger jammed	2. Shut-off and lock-out power, open clean-out door and remove excess material (make sure swivel spout is clear)
<hr/>	
<b>B. AUGER RUNS TOO SLOW:</b>	
1. Engine running too slow	1. Increase engine speed
2. Pump not producing minimum required flow and pressure	2. Check pump capacity and correct
3. Pump is worn	3. Repair or replace pump
4. Internal leak in controls or motor	4. Replace seals; repair or replace valves or motor
5. Air in system	5. Bleed system and tighten connections
6. Improper hydraulic oil viscosity	6. If auger starts slowly and speed increases after oil heats up, oil is too heavy weight. If auger slows down after oil heats up, oil is too light weight
<hr/>	
<b>C. AUGER TURN IN WRONG DIRECTION:</b>	
1. Control valve on tractor not set properly	1. Reset
<hr/>	
<b>D. OIL HEATS EXCESSIVELY.</b>	
1. Oil viscosity incorrect	1. Drain and refill with proper weight oil
2. Dirty oil	2. Drain, flush, and refill with a clean oil and filter
3. Oil level too low	3. Fill to proper level
4. Oil slipping through worn pump	4. Repair or replace pump
5. Restricted line or piping	5. Reroute lines to eliminate restrictions
6. Reservoir too small to provide adequate cooling	6. Replace with larger reservoir or install oil cooler
<hr/>	
<b>E. PUMP / MOTOR SEALS BLOW-SHAFT / HOUSING BREAKS - HOSE BURST:</b>	
1. When a standard control valve is returned to neutral, to stop, or start a motor, sudden pressure is created which may break seals, tear off motor shafts, burst housing or hoses. (Especially at speed under load.) This sudden shock cannot be relieved through the primary relief valve in the system	1. Avoid sudden and rapid starting and stopping (or convert to a free wheeling control valve (on the tractor) or a cushion valve may be installed)

**\*NOTE:** BRUSH FLIGHTING WILL RUN 25% SLOWER THAN STEEL OR PLASTIC FLIGHTING.

## Troubleshooting (Continued)

Occasionally when an auger has been connected into an auxiliary hydraulic system, it may not operate. When hydraulic pressure and flow gauges are not available, it may be difficult to determine if the fault is in the source hydraulic system, or the auger. A convenient method of determining this is to connect the auger hydraulic hoses to another tractor system and check the operation. If, for example, the auger operates from the other tractor system but not from the original tractor connection, or the original tractor system is not adequate. If the auger fails to operate; however, there is probably a fault with the auger control valve, motor or the auger itself. In this case, refer to the trouble shooting guide.

## Complete Torque Chart - Capscrews - Grade 5

### IMPORTANT

- Grade 5 capscrews can be identified by three radial dashes on head.
- Tighten U-bolts to have the same number of threads exposed on each end.

SIZE	FOOT POUNDS	NEWTON METERS	SIZE	FOOT POUNDS	NEWTON METERS
1/4-20	8-10	11-13	3/4-10	200-220	270-300
1/4-28	9-11	12-15	3/4-16	210-230	285-310
5/16-18	15-17	20-23	7/8-9	330-350	425-475
5/16-24	17-19	23-26	7/8-14	360-380	460-515
3/8-16	25-28	34-38	1-8	500-525	675-710
3/8-24	28-31	38-42	1-14	540-560	730-760
7/16-14	40-45	54-61	1 1/8-7	600-635	815-860
7/16-20	45-50	61-68	1 1/8-12	665-700	920-950
1/2-13	62-68	84-92	1 1/4-7	850-895	1150-1215
1/2-20	68-75	92-102	1 1/4-12	940-990	1275-1340
9/16-12	90-98	22-133	1 3/8-6	1125-1175	1525-1590
9/16-18	100-110	134-148	1 3/8-12	1280-1335	1735-1810
5/8-11	120-135	162-183	1 1/2-6	1500-1560	2035-2115
5/8-18	124-137	168-186	1 1/2-12	1685-1755	2285-2380

## Complete Torque Chart - Capscrews - Grade 8

### IMPORTANT

- Grade 8 capscrews can be identified by six radial dashes on head.
- For wheel torque requirements, refer to Wheels and Tires.
- Tighten U-bolts to have the same number of threads exposed on each end.

SIZE	FOOT POUNDS	NEWTON METERS	SIZE	FOOT POUNDS	NEWTON METERS
1/4-20	11-13	15-17	3/4-10	280-295	380-400
1/4-28	12-15	16-20	3/4-16	330-365	445-495
5/16-18	20-22	27-30	7/8-9	410-430	555-580
5/16-24	21-23	28-31	7/8-14	420-440	570-595
3/8-16	35-39	47-53	1-8	630-650	850-880
3/8-24	36-41	49-55	1-14	680-700	920-950
7/16-14	54-58	73-78	1 1/8-7	900-930	1220-1260
7/16-20	55-60	75-80	1 1/8-12	930-950	1260-1290
1/2-13	82-88	110-120	1 1/4-7	1250-1300	1695-1760
1/2-20	94-99	125-135	1 1/4-12	1280-1320	1735-1790
9/16-12	127-134	170-180	1 3/8-6	1665-1715	2250-2325
9/16-18	147-155	199-210	1 3/8-12	1750-1780	2370-2410
5/8-11	160-170	215-230	1 1/2-6	2225-2275	3015-3080
5/8-18	165-175	225-235	1 1/2-12	2285-2330	3100-3160

## Hydraulic Fittings - Torque and Installation

### SAE Flare Connection (J.I.C.)

1. Tighten nut with finger until it bottoms the seat.
2. Using a wrench, rotate nut to tighten. Turn nut 1/3 turn to apply proper torque.

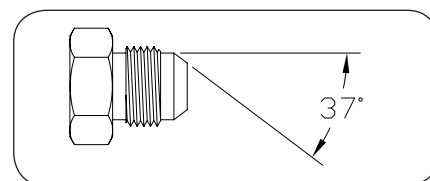

### SAE Straight Thread O-Ring Seal

1. Insure jam nut and washer are backed up to the back side of smooth portion of elbow adapter.
2. Lubricate o-ring -- VERY IMPORTANT!
3. Thread into port until washer bottoms onto spot face.
4. Position elbows by backing up adapter.
5. Tighten jam nut.

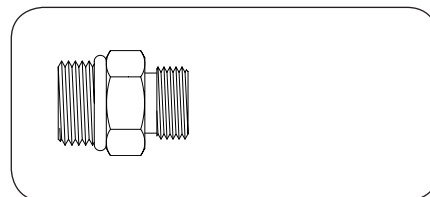

**Notes**

**SECTION V**  
**Parts**

Transport & Pivot Support Stands..... 5-2  
Lower Auger Components..... 5-4  
Upper Auger Components ..... 5-6  
Hopper Components..... 5-8  
Flow Control Valve Kit Components (Optional)..... 5-10  
Check Valve Kit Components (Optional) ..... 5-11

# Drill Fill Auger — Parts

## Transport & Pivot Support Stands

Please visit [www.unverferth.com/parts/](http://www.unverferth.com/parts/) for the most current parts listing.

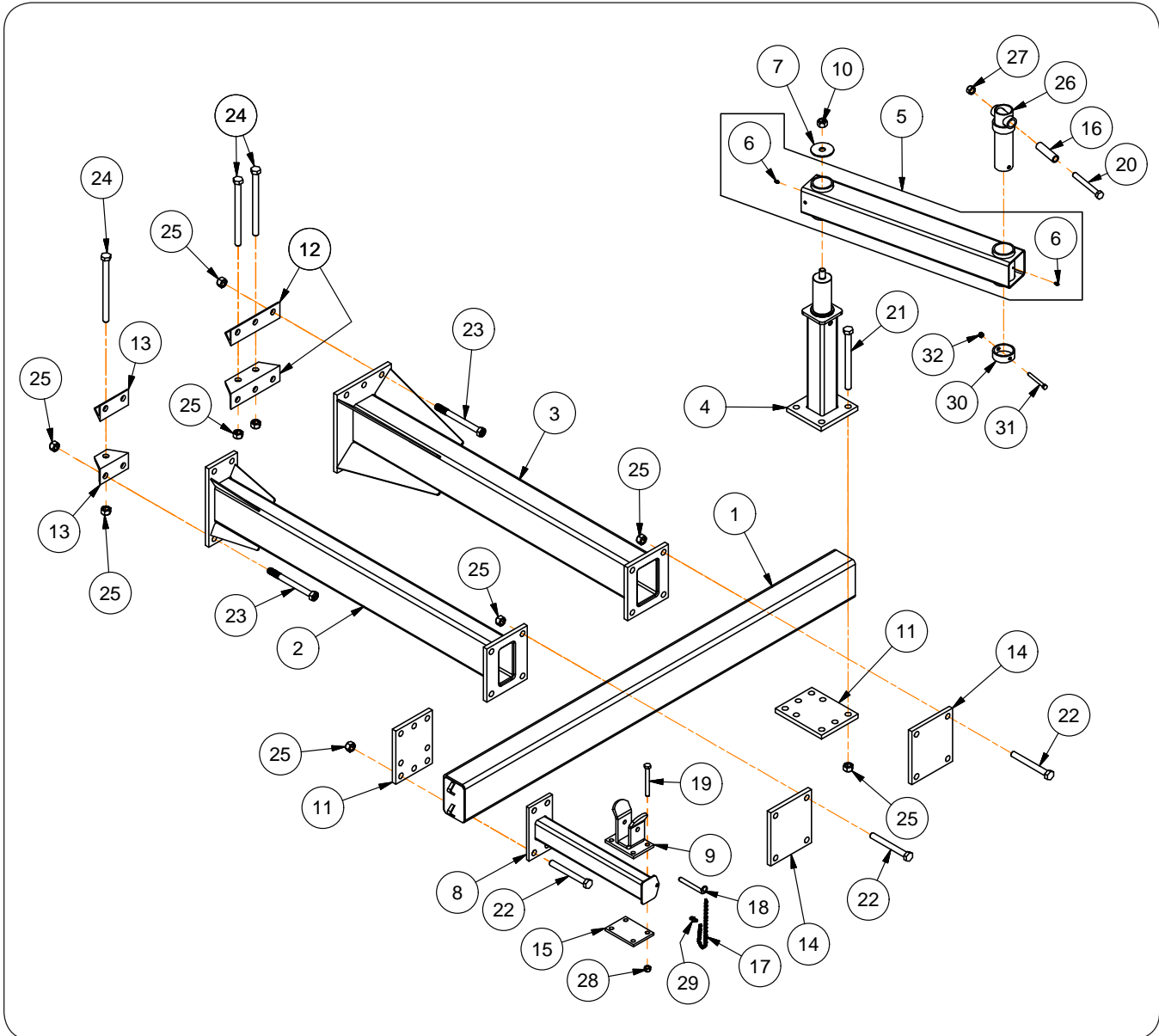

# Drill Fill Auger — Parts

## Transport & Pivot Support Stands

Please visit [www.unverferth.com/parts/](http://www.unverferth.com/parts/) for the most current parts listing.

ITEM	DESCRIPTION	PART NO.	QTY	NOTES
1	Cross Tube Weldment =Black=	2004144B	1	
2	Transport Arm Weldment =Black=	2004139B	1	
3	Main Arm Weldment =Black=	2004136B	1	
4	Vertical Post Assembly	2004146B	1	
5	Pivot Arm Weldment =Black=	23508B	1	Includes Item 6
6	Grease Zerk	91160	2	
7	Washer	23515B	1	
8	Transport Bracket Mounting Tube =Black=	2005106B	1	
9	Transport Bracket Assembly =Black=	2005119B	1	
10	Top Locknut 3/4"-10UNC	9802	1	
11	Plate 6 3/4" x 8 1/2" =Black=	2004150B	2	
12	Angle with 5 Holes =Black=	2004151B	2	
13	Angle with 3 Holes =Black=	2004152B	2	
14	Plate 7 1/2" x 8 1/2" =Black=	2004154B	2	
15	Plate 3 3/4" x 5 1/4" =Black=	2005113B	1	
16	Tube/Bushing	23523	1	
17	Sash Chain	23660	1	
18	Hitch Pin 1/2" Dia. x 4 1/4"	99697	1	
19	Capscrew 1/2"-13UNC x 4 1/2"	9390-112	4	Grade 5
20	Capscrew 5/8"-11UNC x 5 1/2"	9390-135	1	Grade 5
21	Capscrew 3/4"-10UNC x 9"	9390-449	4	Grade 5
22	Capscrew 3/4"-10UNC x 6 1/2"	91299-158	12	Grade 8
23	Capscrew 3/4"-10UNC x 8"	91299-161	10	Grade 8
24	Capscrew 3/4"-10UNC x 10"	91299-257	3	Grade 8
25	Top Locknut 3/4"-10UNC	9802	29	
26	Pivot Weldment =Black=	23452B	1	
27	Top Locknut 5/8"-11UNC	9801	1	
28	Top Locknut 1/2"-13UNC	9800	4	
29	S-Hook	98054	1	
30	Collar =Black=	22409B	1	
31	Capscrew 3/8"-16UNC x 3 1/2"	9390-065	1	Grade 5
32	Top Locknut 3/8"-16UNC	9928	1	

# Drill Fill Auger — Parts

## Lower Auger Components

Please visit [www.unverferth.com/parts/](http://www.unverferth.com/parts/) for the most current parts listing.

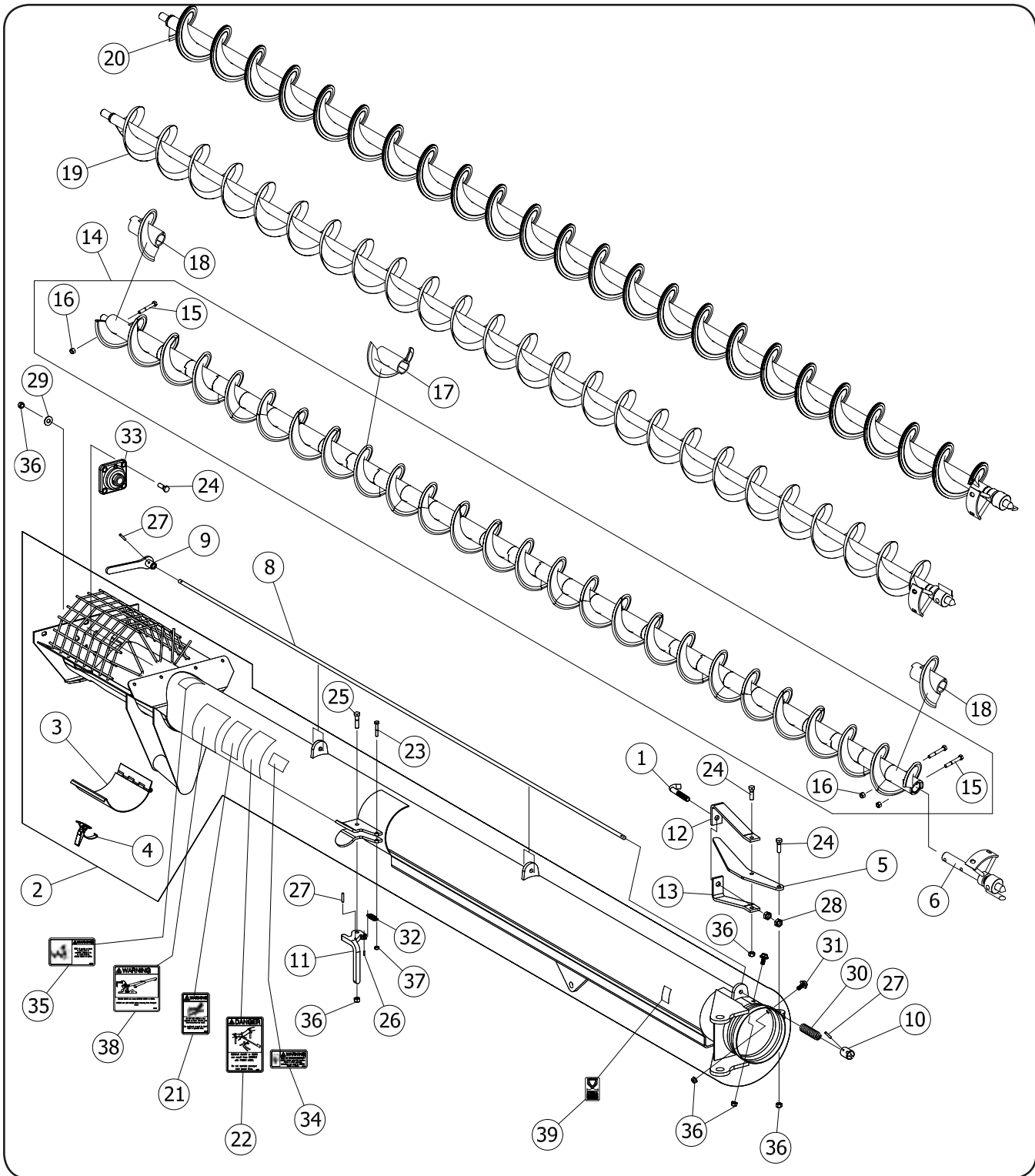



# Drill Fill Auger — Parts

## Lower Auger Components (Continued)

Please visit [www.unverferth.com/parts/](http://www.unverferth.com/parts/) for the most current parts listing.

ITEM	PART NO.	DESCRIPTION	QTY.	NOTES
1	21501	Hook 1/2" Dia.	1	
2	23443B	Lower Auger Weldment	1	Includes Items 3 & 4
	3	2537	Clean-Out Door Weldment	
	4	9220	Draw Latch	
5	23463B	Handle	1	
6	25561B	Shaft Weldment		For Plastic Flighting Only
7	99936	Bronze Bearing		
8	23483B	Bar 3/8" Dia. x 85 1/4	1	
9	23486B	Handle Weldment	1	
10	23493B	Coupler 1" Dia.	1	
11	23505B	Latch/Plate	1	
12	23518B	Strap 1 1/4 x 10 9/32	1	
13	23519B	Strap 1 1/4 x 10	1	
14	900301	Plastic Flighting Assembly		
	15	91484	Capscrew 5/16-18UNC x 2 1/4	
	16	92929-007	Elastic Stop Nut 5/16-18UNC	
	17	900199	Plastic Flight Section	
	18	901122	Plastic Flight Section w/Gusset	
19	23469B	Steel Flighting Weldment		
20	23528B	Brush Flighting Weldment		
21	93551	Decal, WARNING (Hydraulic Leaks)	1	
22	93558	Decal, DANGER (Electrical)	1	
23	9390-007	Capscrew 1/4-20UNC x 1 1/2	1	Grade 5
24	9390-056	Capscrew 3/8-16UNC x 1 1/4	2	Grade 5
25	9390-057	Capscrew 3/8-16UNC x 1 1/2	1	Grade 5
26	9392-051	Roll Pin 1/8" Dia. x 7/16	1	
27	9392-097	Roll Pin 3/16" Dia. x 1	2	
28	9395-010	Hex Jam Nut 1/2-13UNC	2	Grade 5
29	9405-076	Flat Washer 3/8		
30	95043	Compression Spring 3" Long	1	
31	95585	Capscrew/Large Flange 3/8-16UNC x 3/4		Grade 5
32	95831	Extension Spring 1 3/4" Long	1	
33	9735	Flange Bearing w/ 4 Holes		
34	97961	Decal, WARNING (Read & Understand)	1	
35	98766	Decal, WARNING (Rotating Auger)	1	
36	9928	Locknut 3/8-16UNC	3	
37	9936	Locknut 1/4-20UNC	1	
38	99960	Decal, WARNING (Falling Auger)	1	
39	91605	Decal, FEMA	1	

# Drill Fill Auger — Parts

## Upper Auger Components

Please visit [www.unverferth.com/parts/](http://www.unverferth.com/parts/) for the most current parts listing.

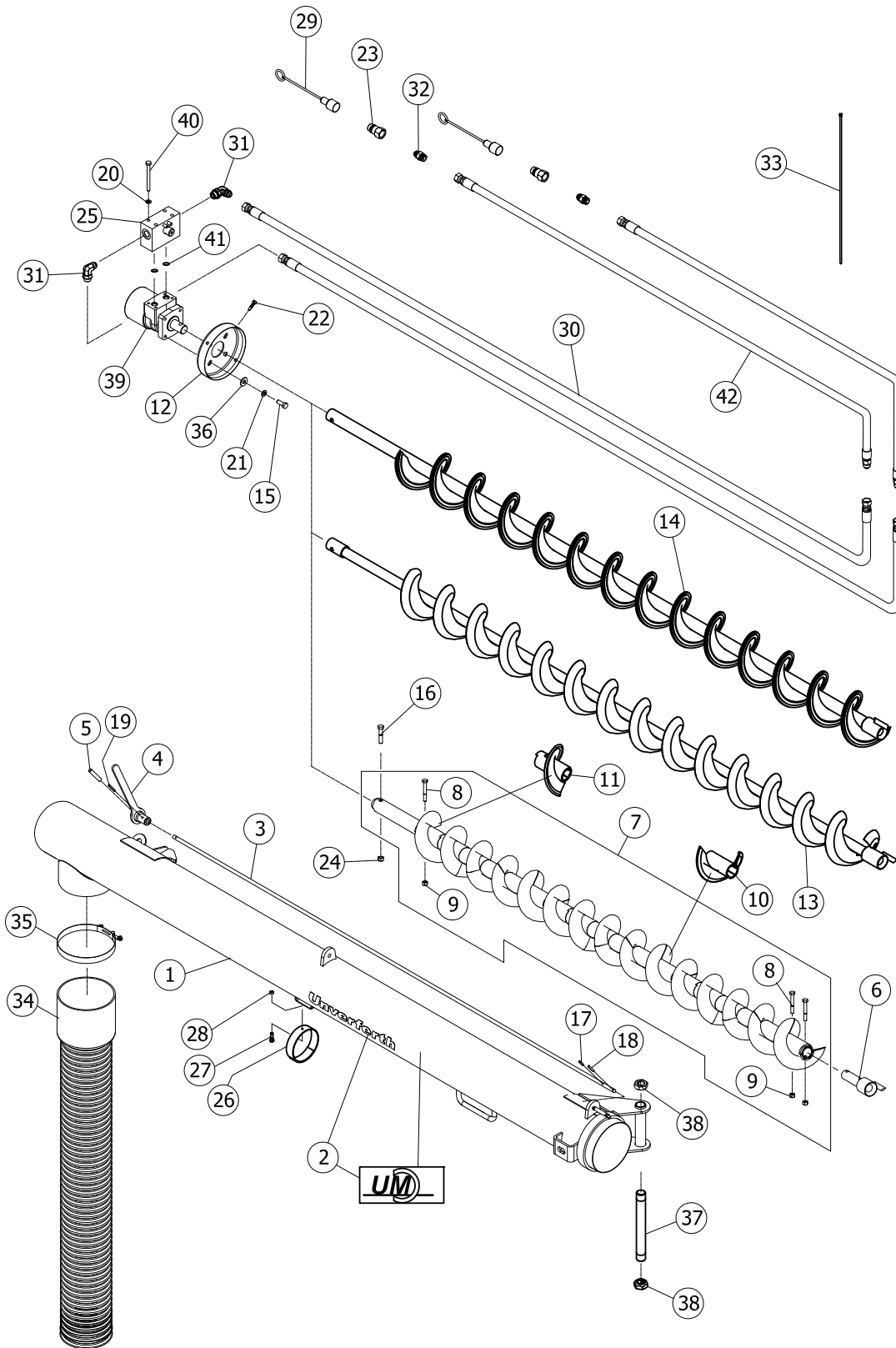

# Drill Fill Auger — Parts

## Upper Auger Components (Continued)

Please visit [www.unverferth.com/parts/](http://www.unverferth.com/parts/) for the most current parts listing.

ITEM	PART NO.	DESCRIPTION	QTY.	NOTES
1	23739B	Upper Auger Weldment w/Decal	1	
	2	901607	Decal, UM Oval Logo	2
		901725	Decal, UNVERFERTH Logo	2
3	23487B	Shaft 3/8" Dia. x 85	1	
4	23492B	Handle Weldment	1	
5	23494	Pin 3/8" Dia. x 2	1	
6	23885	Coupler Weldment		For Plastic Flighting Only
7	900302	Plastic Flight Assembly		
	8	91484	Capscrew 5/16-18UNC x 2 1/4	
	9	92929-007	Elastic Stop Nut 5/16-18UNC	
	10	900199	Plastic Flight Section	
	11	901122	Plastic Flight Section w/Gusset	
12	2865B	End Cap	1	
13	23479B	Steel Flighting Weldment		
14	23534B	Brush Flighting Weldment		
	9390-055	Capscrew 3/8-16UNC x 1	4	
15	9390-058	Capscrew 3/8-16UNC x 1 3/4	1	
16	9392-093	Roll Pin 3/16" Dia. x 3/4	1	
17	9392-097	Roll Pin 3/16" Dia. x 1	1	
18	9392-098	Roll Pin 3/16" Dia. x 1 1/8	1	
19	9404-019	Lock Washer 5/16"	4	
20	9404-021	Lock Washer 3/8"	4	
21	9512	Self-Drilling Screw 1/4-14 x 1	4	
22	91383	Male Tip Coupling 3/4-16	2	
23	9928	Locknut 3/8-16UNC	1	
24	99933	Valve, Manifold Mount	1	
	96918	Seal Kit	-	
25	108088	Strap 2 x 28 w/6" Hook & Loop Ends	1	
26	9390-002	Capscrew 1/4-20UNC x 5/8	1	
27	9936	Locknut 1/4-20UNC		
28	91511	Dust Cap	2	
29	95964	Hose 1/2" Dia. x 185	2	
30	9863	90° Elbow 3/4-16 JIC Male	2	
		x 3/4-16 O-Ring Adj. Male Boss		
31	9864	Adapter 3/4-16 JIC Male	2	
		x 3/4-16 O-Ring Male Boss		
32	94038	Cable Tie 32" long	15	
33	97094	Flexible Spout	1	
34	98060	Clamp		
35	9405-076	Flat Washer 3/8" USS	4	
36	23975	Pin 7/8" Dia. x 7 7/8	1	
37	96976-036	Locknut/Thin 7/8-14UNC	2	
38	91604B	Hydraulic Motor	1	
	91687	Seal Kit	-	
39	9390-040	Capscrew 5/16-18UNC x 3 1/2	4	
40	91306	O-Ring	-	
41	9882	Hose 1/2" x 102"	2	
42				

# Drill Fill Auger — Parts

## Hopper Components

Please visit [www.unverferth.com/parts/](http://www.unverferth.com/parts/) for the most current parts listing.

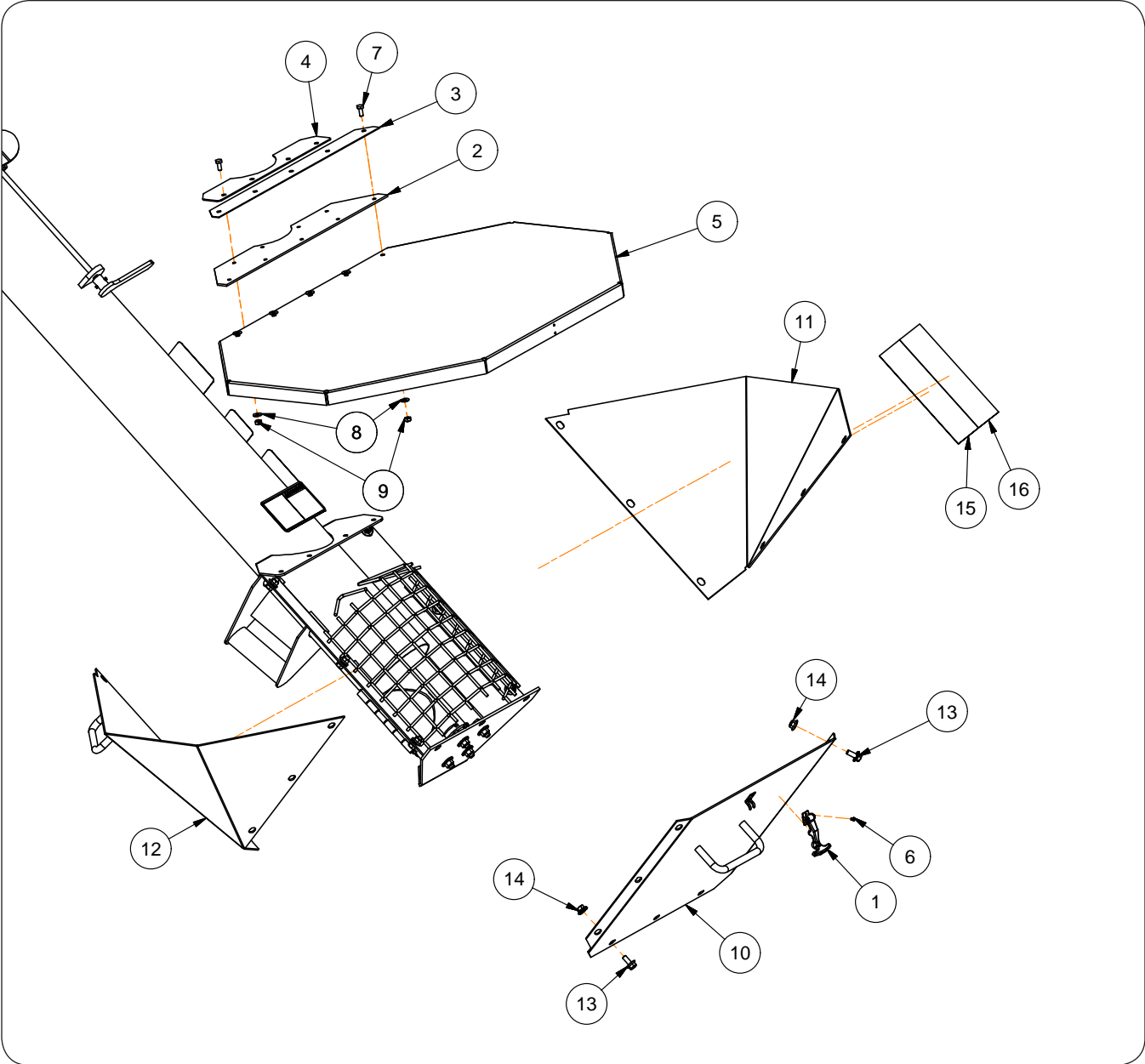

# Drill Fill Auger — Parts

## Hopper Components

Please visit [www.unverferth.com/parts/](http://www.unverferth.com/parts/) for the most current parts listing.

ITEM	PART NO.	DESCRIPTION	QTY.	NOTES
1	104988	Draw Latch	1	
2	108021	Hopper Seal 3 1/4 x 20	1	
3	23270B	Plate 1 5/8 x 20	1	
4	23271B	Plate 2 1/4 x 14	1	
5	23661B	Lid Weldment =Black=	1	
6	903104	Pop Rivet 1/8"	2	
7	9390-002	Capscrew 1/4"-20UNC x 5/8"	9	Grade 5
8	9405-062	Flat Washer 1/4" SAE	9	
9	9936	Top Locknut 1/4"-20UNC	9	
10	108020B	Hopper Back Panel Weldment	1	
11	23150B	Hopper Panel Weldment	1	
12	23151B	Hopper Panel Weldment	1	
13	91256	Flange Screw 5/16"-18UNC x 3/4"	15	
14	91257	Large Flange Nut 5/16"-18UNC	15	
15	9003125	Decal, Fluorescent ORANGE	1	
16	9003126	Decal, Reflector RED	1	

# Drill Fill Auger — Parts

## Flow Control Valve Kit Components (Optional)

Please visit [www.unverferth.com/parts/](http://www.unverferth.com/parts/) for the most current parts listing.

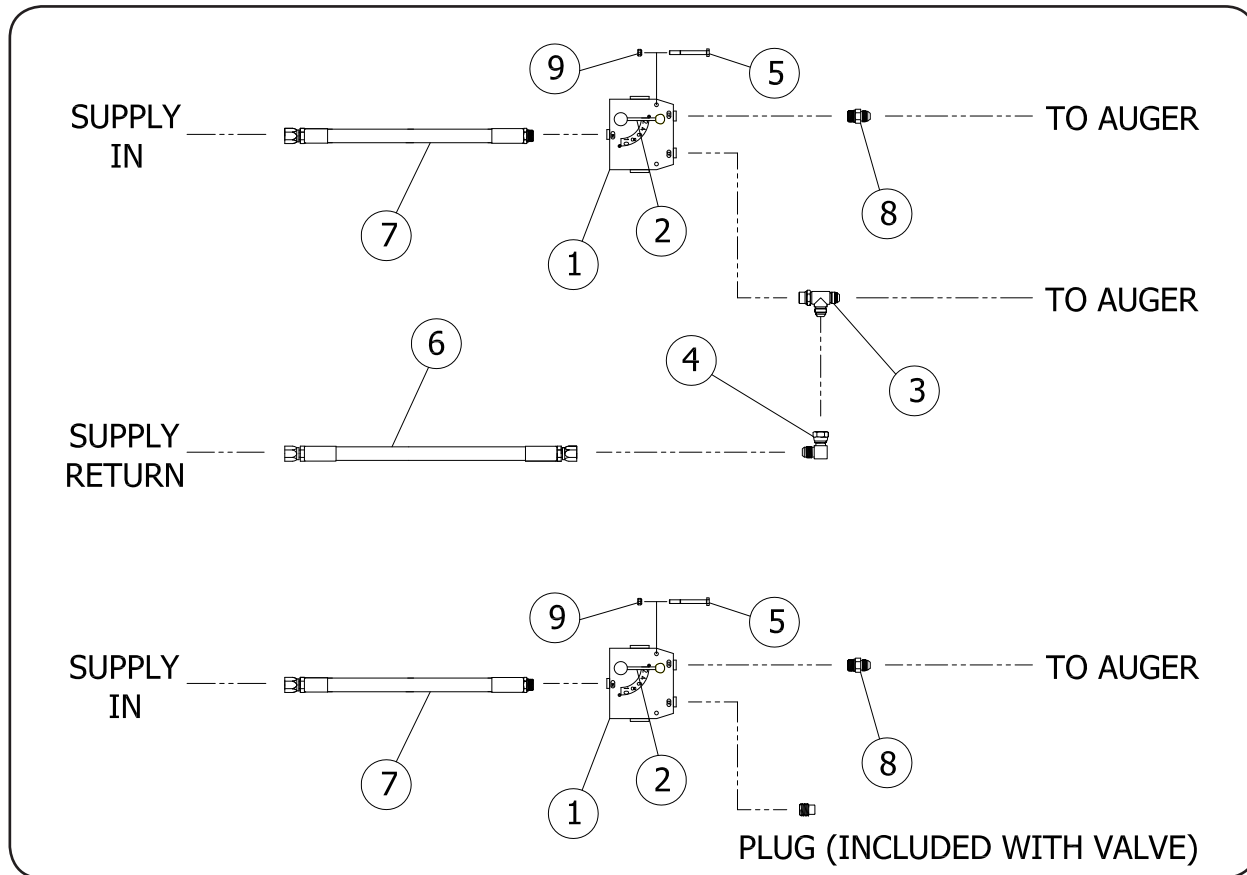

ITEM	PART NO.	DESCRIPTION
	23669	Flow-Control Valve Kit For Open-Center Systems & Closed-Center Systems
1	9000832	Flow Control Valve Less Handle
2	900241	Handle
3	93588	Tee
4	93683	Elbow 90°
5	9390-011	Capscrew 1/4-20UNC x 2 1/2"
6	95144	Hose 1/2 x 20" Lg.
7	97742	Hose 1/2 x 18" Lg.
8	9864	Adapter
9	9936	Locknut 1/4-20UNC

# Drill Fill Auger — Parts

## Check Valve Kit Components (Optional)

Please visit [www.unverferth.com/parts/](http://www.unverferth.com/parts/) for the most current parts listing.

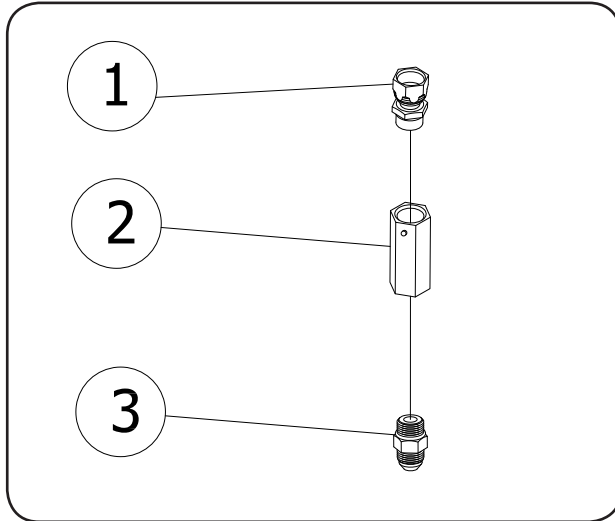

ITEM	PART NO.	DESCRIPTION
	23336	Check Valve Kit (Anti-Reverse)
1	96935	Adapter
2	97740	Check Valve
3	9864	Adapter



***Unverferth***<sup>®</sup>  
***Manufacturing Company, Inc.***

[www.unverferth.com](http://www.unverferth.com)