



Seed Handling System

CROSS AUGER

Beginning With Serial Number A62930100 & Higher

Part No. 2005434

Foreword

 This symbol identifies important safety messages. When you see it, read the message that follows and be alert to the possibility of personal injury.

Remember, safety instructions stated in this manual are for your protection. Read them carefully and follow them closely when working around or using this machine.

Read and study this manual completely before attempting to operate this implement. Take this manual to the field for handy reference when operating, adjusting, or servicing your machine.

When referenced, “Right-Hand” (RH) and “Left-Hand” (LH) side of the machine are determined by standing behind the machine and facing in the direction of travel.



Product Information

When ordering parts or when requesting further information or assistance, always provide the following information:

- Machine name
- Serial number

All products manufactured by Unverferth Mfg. Co., Inc. are warranted to be free from material and workmanship defects for one full year from time of consumer delivery. Your local dealer will gladly assist you with any warranty questions.

Please fill out and retain this portion for your records. The serial number plate is located on the auger tube, next to the fill hopper (Fig. 1).

Purchase Date _____ Model _____ Serial No. _____

Installed On Planter Make _____ Model Number _____

Dealer _____ City _____

Dealer Contact _____ Phone _____

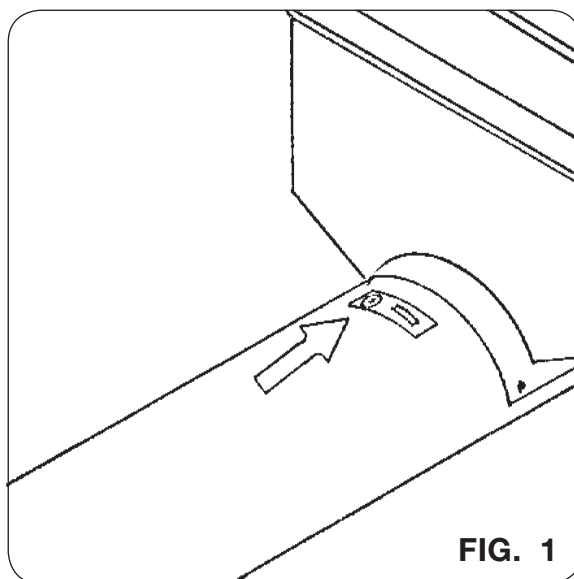

IMPORTANT

The information, specifications, and illustrations in the manual are on the basis of information available at the time it was written. Due to continuing improvements in the design and manufacture of Unverferth products, all specifications and information contained herein are subject to change without notice.

Table of Contents

Foreword.....2
Product Information.....3

**SECTION I
Safety**

General Hazard Information.....1-2
Safety Decals.....1-3
Following Safety Instructions1-4
Before Operating or Servicing1-4
During Operation.....1-4
Pressurized Oil.....1-5
Preparing for Emergencies1-6
Wearing Protective Equipment.....1-6

**SECTION II
Setup**

Assembly Instructions - All Machines
Pre-Assembly Safety Information2-2
Cross Auger For 6 Row Narrow Planters
Except Case IH 800/900/950/955/1200/1220/1225, New Holland 480.....2-3
Cross Auger For 8 Row Narrow Planters
Except Case IH 800/900/950/955/1200/1220/1225, New Holland 480.....2-7
Cross Auger For 12 Row Narrow John Deere 7000 Front-Fold,
John Deere 1770, John Deere 7200 Flex-Fold,
& White 6180/8180 Forward Fold Planters.....2-10
Cross Auger For 16 Row Narrow
John Deere 1770, John Deere 7000, John Deere 7200 Planters.....2-12
Cross Auger For 16 Row Narrow Planters
White 6180/8180.....2-15
Cross Auger For 6 Row Narrow Planters
Case IH 800/900/950/955/1200/1220/1225 & New Holland 480 Planters2-17
Cross Auger For 8 Row Narrow Planters
Case IH 1200/1220/1225 & New Holland 480 Planters2-19
Hydraulic Hook-Up Recommendations.....2-22
Check Valve.....2-22
System Capacity Requirements.....2-23
Install Hydraulic Lines.....2-23
12 & 16 Row Hydraulic Hook-Up Diagram.....2-24
Speed Control Valve Optional Package #21125.....2-25
Relief Valve Bundle (Optional) #23647.....2-27

Table of Contents (continued)

SECTION III
Operation

Hydraulic Hook-Up3-2
Auger Operation.....3-2
 Filling Planter.....3-2
 Shut-Off Flow to Planter.....3-3
 Adjusting Shut-Off Door3-3
Performance3-4
Transporting.....3-4

SECTION IV
Maintenance

General Maintenance.....4-2
Lubrication4-2
Troubleshooting
 Auger Will Not Turn Over or Develop Proper Speed/Torque.....4-3
 Auger Runs Too Slow4-3
 Auger is Turning in Wrong Direction4-4
 Oil Heat Excessively.....4-4
 Pump/Motors/Seals Blow - Shaft/Housing Breaks - Hose Burst.....4-4

Table of Contents (continued)

SECTION V
Parts

Mounting Bracket Components	
For 6 & 8 Row Narrow Planters.....	5-2
Mounting Bracket Components	
For 6 & 8 Row Narrow Kinze 2500/3500 Planters.....	5-3
Mounting Bracket Components	
For 12 Row Narrow Planters	
John Deere 7000, John Deere 1770, John Deere 7200 Forward Fold,	
& White 6180/8180 Forward Fold	5-4
Mounting Bracket Components	
For 16 Row Narrow Planters	
John Deere 1770, John Deere 7200 Flex Fold	
& White 6180/8180 Forward Fold	5-5
Motor/Valve/Motor Mounting End Cap	5-6
Molded Part, Hardware, & Decals	5-8
Auger Tube & Flighting	
For 6 Row Narrow Planters.....	5-10
For 8 Row Narrow Planters.....	5-11
For 12 Row Narrow Planters.....	5-12
For 16 Row Narrow Planters.....	5-13
Stiffener Brace/Clamps.....	5-14
End Bearing and Shaft Components	5-15
Control Valve Package #21125 (Optional)	5-16
Relief Valve Bundle #23647 (Optional).....	5-16
Valve/3-Way Selector #91280 (Optional)	5-17

SECTION I

Safety

General Hazard Information.....	1-2
Safety Decals.....	1-3
Following Safety Instructions.....	1-4
Before Operating or Servicing.....	1-4
During Operation.....	1-4
Pressurized Oil.....	1-5
Preparing for Emergencies.....	1-6
Wearing Protective Equipment.....	1-6

General Hazard Information

No accident-prevention program can be successful without the wholehearted cooperation of the person who is directly responsible for the operation of the equipment.

A large number of accidents can be prevented only by the operator anticipating the result before the accident is caused and doing something about it. No power-driven equipment, whether it be transportation or processing, whether it is on the highway, in the field, or in the industrial plant, can be safer than the person who is at the controls. If accidents are to be prevented--and they can be prevented--it will be done by the operators who accept the full measure of their responsibility.

It is true that the designer, the manufacturer, and the safety engineer can help; and they will help, but their combined efforts can be wiped out by a single careless act of the operator.

It is said that, "the best kind of a safety device is a careful operator." We, at Unverferth Mfg. Co., Inc. ask that you be that kind of operator.



REMEMBER:
THINK SAFETY
A CAREFUL OPERATOR IS THE
BEST INSURANCE AGAINST AN
ACCIDENT!

SIGNAL WORDS



INDICATES AN EXTREMELY HAZARDOUS SITUATION OR ACTION THAT WILL RESULT IN SERIOUS INJURY OR DEATH.



INDICATES A HAZARDOUS SITUATION OR ACTION THAT COULD RESULT IN SERIOUS INJURY OR DEATH.



INDICATES AN UNSAFE SITUATION OR ACTION THAT MAY RESULT IN PERSONAL INJURY.



Is used for instruction on operating, adjusting, or servicing a machine.

Safety Decals

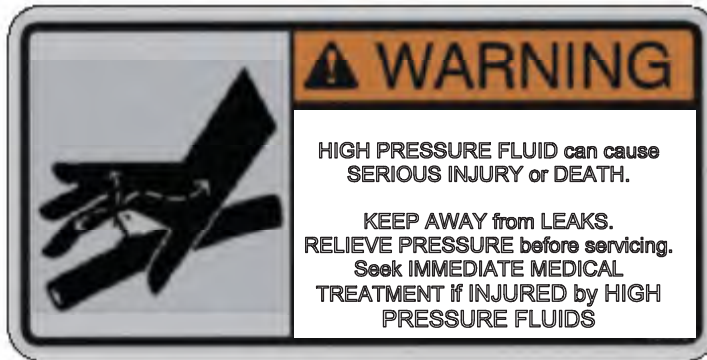

**Part Number
95445**

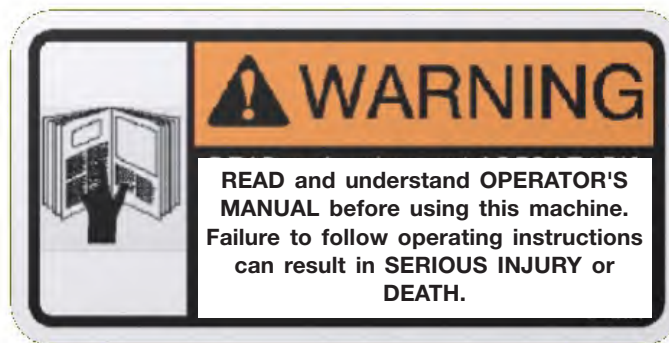

**Part Number
97961**

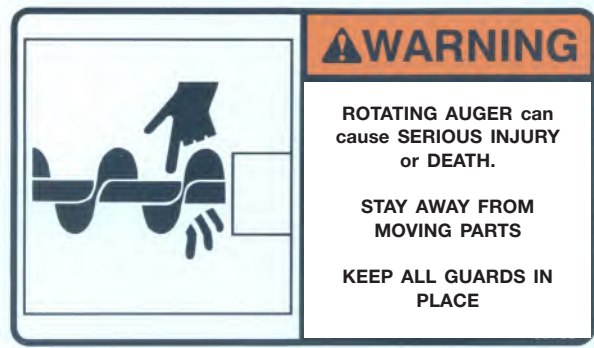

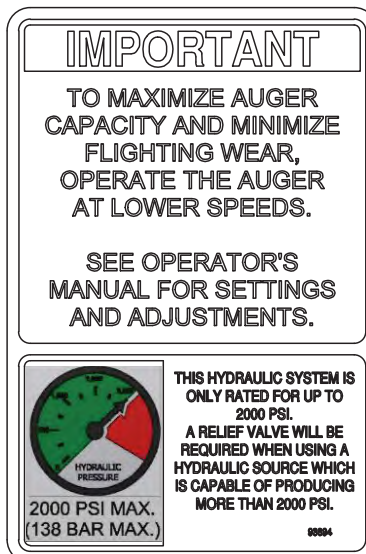

**Part Number
98766**



**Part Number
93694**

Following Safety Instructions

- Read and understand this operator's manual before operating. 
- All machinery should be operated only by trained and authorized personnel.
- To prevent machine damage, use only attachments and service parts approved by the manufacturer.
- Always shut tractor engine off and remove key before servicing. 
- Avoid personal attire such as loose fitting clothing, shoestrings, drawstrings, pants cuffs, long hair, etc., that may become entangled in moving parts.
- Do not allow anyone to ride on the implement. Make sure everyone is clear before operating machine or towing vehicle. 

Before Operating or Servicing

- Avoid working under an implement; however, if it becomes absolutely unavoidable, make sure the implement is safely blocked. 
- Always make certain everyone and everything is clear of the machine before beginning operation.
- Verify that all safety shields are in place and properly secured.
- Ensure that all applicable safety decals are installed and legible.

During Operation

- Never lubricate equipment when in operation.
- Keep away from overhead power lines. Electrical shock can cause serious injury or death.
- Use extreme care when operating close to ditches, fences, or on hillsides.
- Do not leave towing vehicle unattended with engine running.
- Seed being transported may contain seed treatment. Read and follow all requirements for personal protective equipment and first aid as outlined on seed tags.

Pressurized Oil

- Relieve pressure before disconnecting hydraulic lines from the tractor, loosening any hydraulic fittings or servicing the hydraulic system. See the hydraulic power unit manual for the procedure to relieve pressure.

- Use a piece of cardboard or wood to detect leaks of hydraulic fluid under pressure. Correct hydraulic leaks immediately.

- High-pressure fluids can penetrate the skin and cause serious injury or death. Seek medical treatment immediately if injured by high-pressure fluids.

- Hydraulic system must be purged of air before operating to prevent serious injury or death.

- Do not bend or strike high-pressure lines. Do not install bent or damaged tubes or hoses.

- Repair all oil leaks. Leaks can cause fires, personal injury, and environmental damage.

- Route hoses and lines carefully to prevent premature failure due to kinking and rubbing against other parts. Make sure that all clamps, guards and shields are installed correctly.

- Check hydraulic hoses and tubes carefully. Replace components as necessary if any of the following conditions are found:
 - End fittings damaged, displaced, or leaking.
 - Outer covering chafed or cut and wire reinforcing exposed.
 - Outer covering ballooning locally.
 - Evidence of kinking or crushing of the flexible part of a hose.
 - Armoring embedded in the outer cover.

Prepare for Emergencies

- Keep a first aid kit and properly rated fire extinguisher nearby.



- Keep emergency numbers for fire, rescue, and poison control personnel near the phone.



Wearing Protective Equipment

- Wear clothing and personal protective equipment appropriate for the job.



- Wear steel-toed shoes when operating.



- Wear hearing protection when exposed to loud noises.



- Do not wear additional hearing impairing devices such as radio headphones, etc



SECTION II

Setup

Assembly Instructions - All Machines	
Pre-Assembly Safety Information	2-2
Cross Auger For 6 Row Narrow Planters	
Except Case IH 800/900/950/955/1200/1220/1225, New Holland 480	2-3
Cross Auger For 8 Row Narrow Planters	
Except Case IH 800/900/950/955/1200/1220/1225, New Holland 480	2-7
Cross Auger For 12 Row Narrow John Deere 7000 Front-Fold, John Deere 1770, John Deere 7200 Flex-Fold, & White 6180/8180 Forward Fold Planters.....	2-10
Cross Auger For 16 Row Narrow John Deere 1770, John Deere 7000, John Deere 7200 Planters.....	2-12
Cross Auger For 16 Row Narrow Planters White 6180/8180.....	2-15
Cross Auger For 6 Row Narrow Planters Case IH 800/900/950/955/1200/1220/1225 & New Holland 480 Planters	2-17
Cross Auger For 8 Row Narrow Planters Case IH 1200/1220/1225 & New Holland 480 Planters	2-19
Hydraulic Hook-Up Recommendations.....	2-22
Check Valve.....	2-22
System Capacity Requirements.....	2-23
Install Hydraulic Lines.....	2-23
12 & 16 Row Hydraulic Hook-Up Diagram.....	2-24
Speed Control Valve Package (Optional) #21125	2-25
Relief Valve Bundle (Optional) #23647.....	2-27

Assembly Instructions - All Machines

Pre-Assembly Safety Information

WARNING

- HIGH-PRESSURE FLUIDS CAN PENETRATE THE SKIN AND CAUSE SERIOUS INJURY OR DEATH. SEEK MEDICAL TREATMENT IMMEDIATELY IF INJURED BY HIGH-PRESSURE FLUIDS. USE CARDBOARD OR WOOD TO DETECT LEAKS IN THE HYDRAULIC SYSTEM.
- FALLING OBJECTS CAN CAUSE SERIOUS INJURY OR DEATH. DO NOT WORK UNDER THE MACHINE AT ANY TIME WHILE BEING HOISTED. BE SURE ALL LIFTING DEVICES AND SUPPORTS ARE RATED FOR THE LOADS BEING HOISTED. THESE ASSEMBLY INSTRUCTIONS WILL REQUIRE SAFE LIFTING DEVICES UP TO 500 LBS. SPECIFIC LOAD RATINGS FOR INDIVIDUAL LOADS WILL BE GIVEN AT THE APPROPRIATE TIME IN THE INSTRUCTIONS.
- EYE PROTECTION AND OTHER APPROPRIATE PERSONAL PROTECTIVE EQUIPMENT MUST BE WORN WHILE SERVICING THIS IMPLEMENT.
- KEEP HANDS CLEAR OF PINCH POINT AREAS.

CAUTION

- SHARP EDGES ON MARKER BLADES CAN CAUSE INJURY. BE CAREFUL WHEN WORKING AROUND MARKER BLADES.

Follow these pre-assembly instructions to ensure the proper safety and operation.

1. Park on firm, level surface lower implement to ground, block from moving, set parking brake, shut-off engine, remove ignition key.
2. Relieve all hydraulic pressure on planter before installing. See tractor operators manual for procedures.
3. Lock markers in transport position.
4. Use 500 lb. minimum safe lifting device for the auger.
5. Remember to tighten loosened hardware and re-torque to manufacturer's specifications. See planter operators manual for further information.

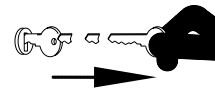

Cross Auger For 6 Row Narrow Planters Except Case I.H. 800/900/950/955/1200/1220/1225, New Holland 480)

Before beginning assembly, refer to pre-assembly instructions for all machines on page 2-2.

1. Determine the vertical support tube position required for your particular planter (Fig. 1-1).

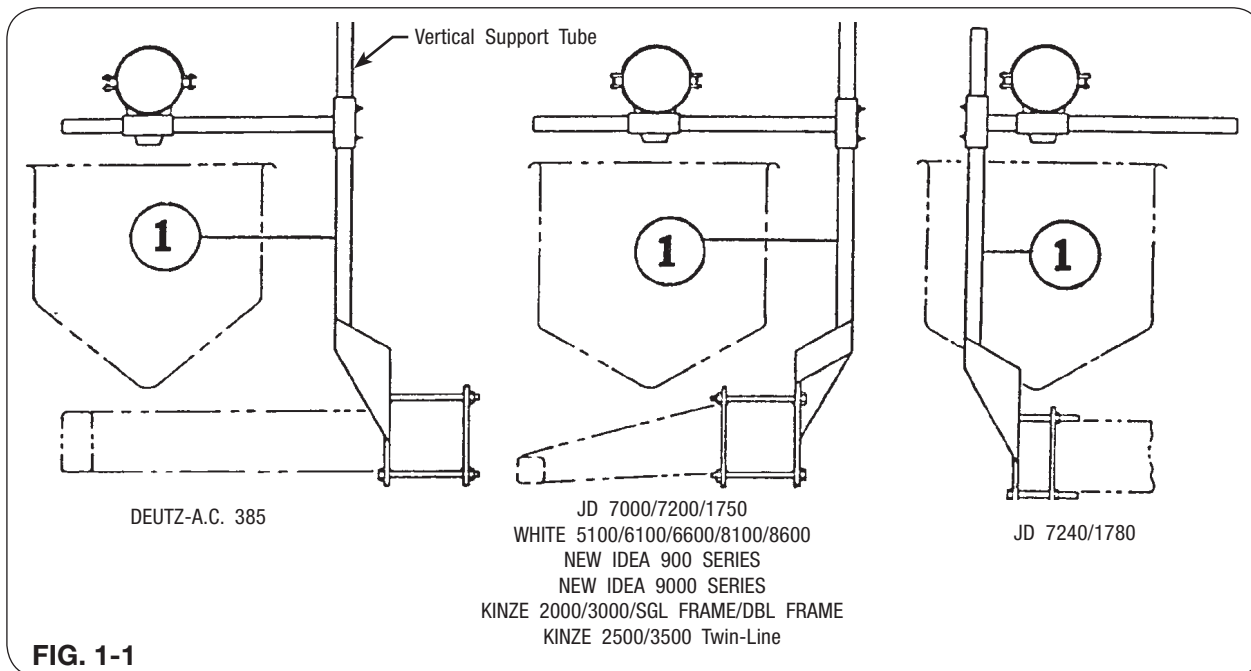

Cross Auger For 6 Row Narrow Planters

Except Case I.H. 800/900/950/955/1200/1220/1225, New Holland 480) (continued)

NOTE: ON JOHN DEERE PLANTERS equipped with frame mounted coulters, install the L.H. vertical support, as shown in Fig. 1-2.

2. ON JOHN DEERE PLANTERS with frame mounted coulters, install L.H. vertical support tube (2003039B) onto planter row unit (Fig. 1-2). The row unit should be safely blocked before removing any hardware.

- A. Lower planter to the ground and remove mounting hardware from L.H. side of row unit.
- B. Install vertical support tube as shown in Fig. 1-2. Fasten to planter frame using 3/4-10 locknut (9802).
- C. Retain into position using bolt and nut furnished with planter.

NOTE: On some planters (with certain options and row spacing) it may be necessary to install L.H. Vertical support tube onto the planter row unit. To do this, lower planter to the ground and remove nuts from outside U-bolt on L.H. row unit. Position support tube onto U-bolt (or use bolts and backing plate furnished) reinstall nuts and tighten (Fig. 1-3).

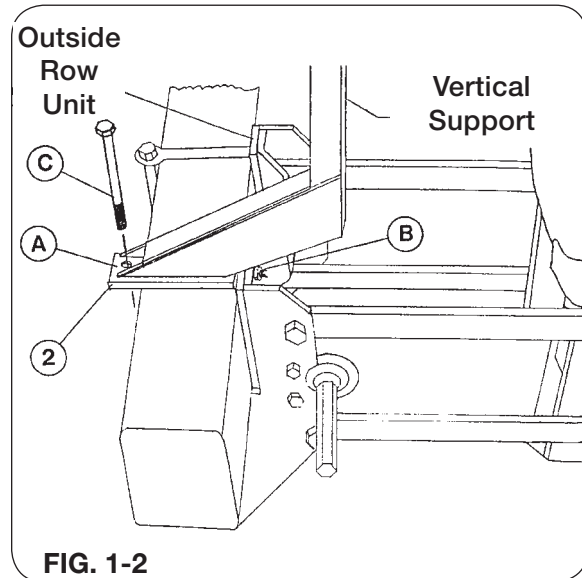

FIG. 1-2

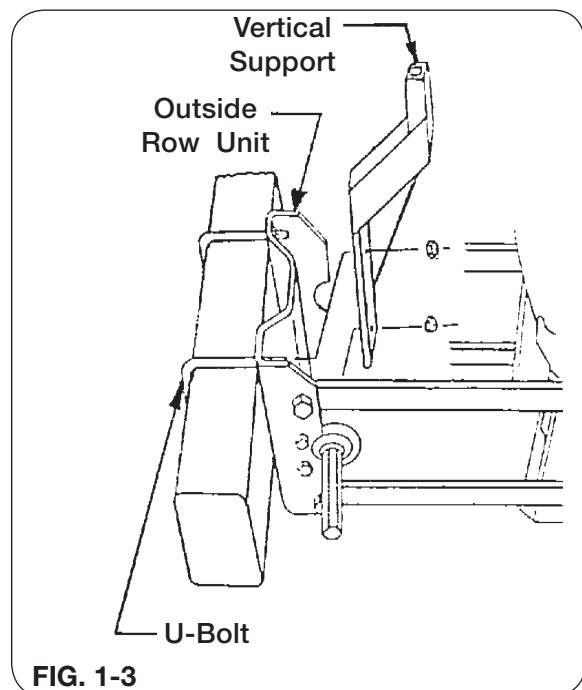
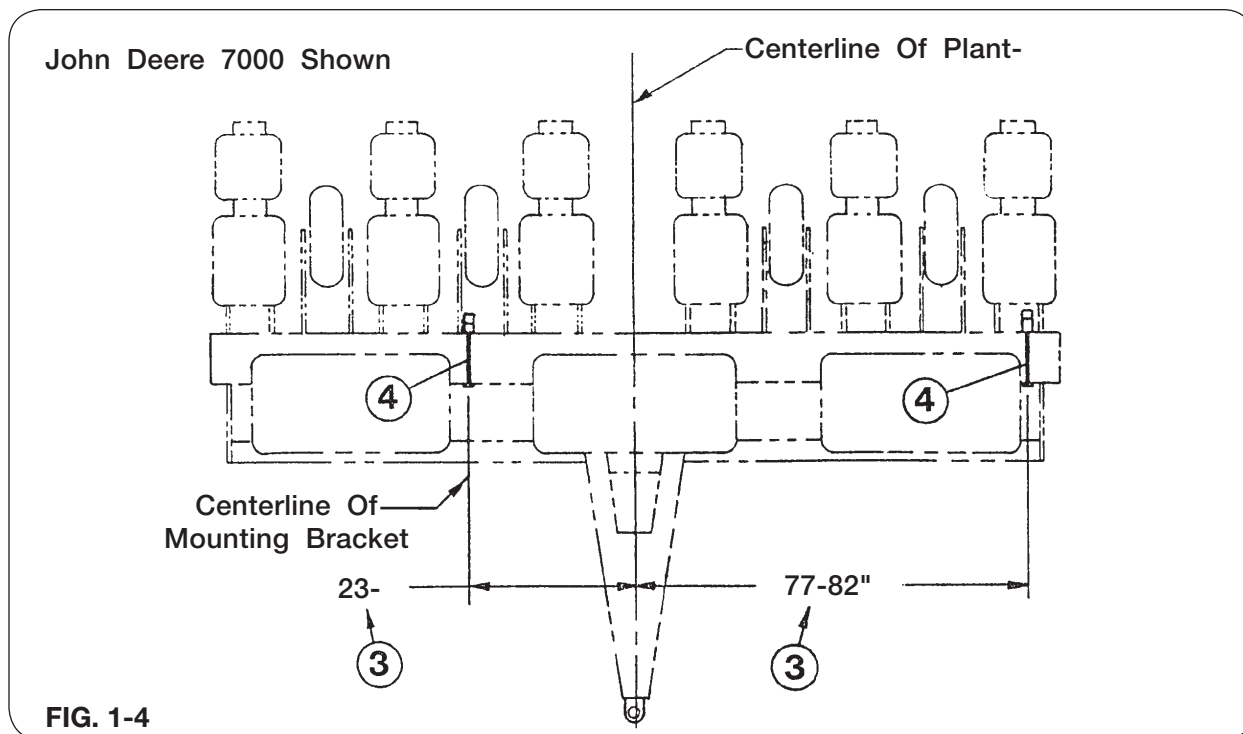

FIG. 1-3

Cross Auger For 6 Row Narrow Planters

Except Case I.H. 800/900/950/955/1200/1220/1225, New Holland 480) (continued)

3. Locate the vertical support tubes onto planter main frame (Fig. 1-4).



Cross Auger For 6 Row Narrow Planters

Except Case I.H. 800/900/950/955/1200/1220/1225, New Holland 480) (continued)

4. Install vertical support tubes (2003035B) onto planter main frame (Fig. 1-4 and Fig. 1-5) using clamp plates (20453), 5/8"-11UNC x 9 1/2" capscrews (91435), 5/8" lock washers (9404-029), and 5/8"-11 hex nuts (9394-014).
5. Install horizontal support tube (20355) onto vertical tubes and tighten set screws (Fig. 1-5).

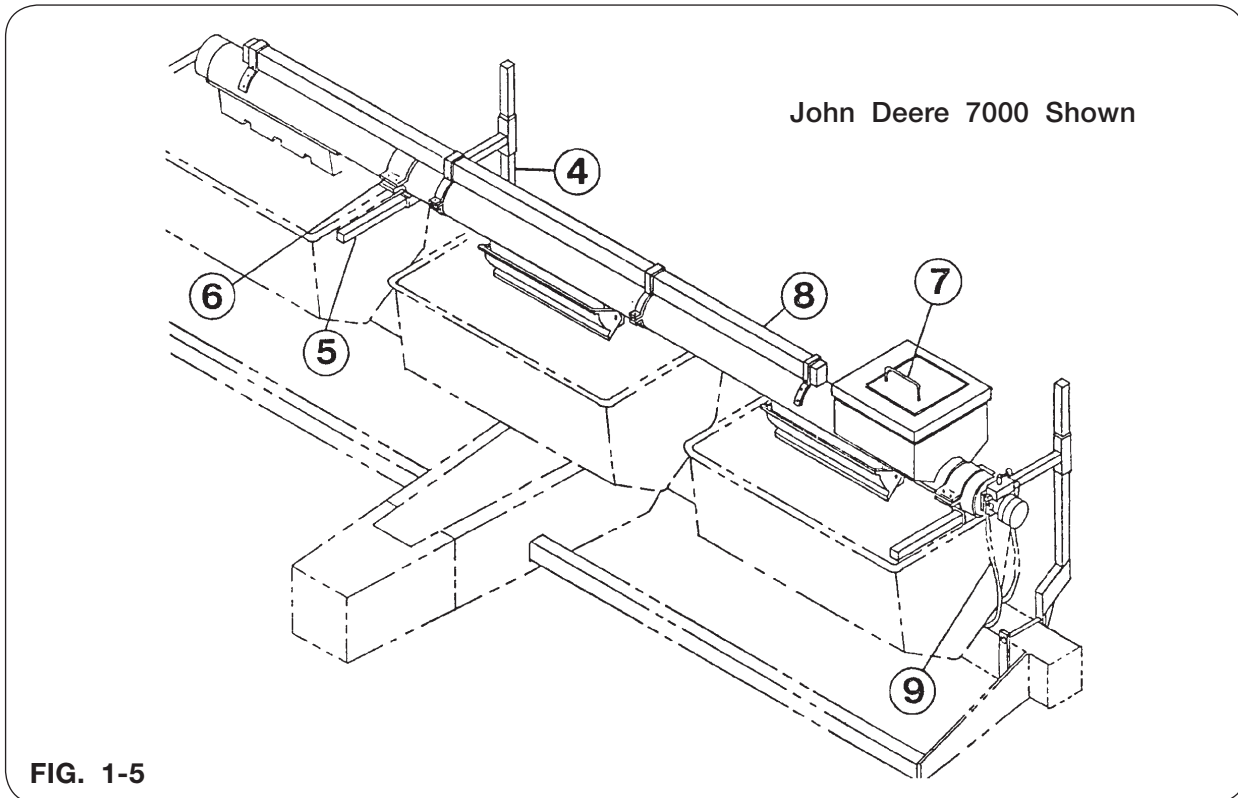

NOTE: For initial set-up position bottom of horizontal tube approximately eight inches above top of fertilizer boxes on planter.

6. Install auger support brackets (20827) onto horizontal support tubes and align with center of fertilizer boxes and planter. Tighten set screws.
7. Reposition handle from shipping position to top of lid.
8. Position cross auger tube assembly onto support bracket and align auger discharge openings over center of planter fertilizer boxes. Retain into position with clamp straps (20819) using 3/8"-16 x 1 1/4" capscrews (9390-056) and 3/8"-16 locknuts (9928).

NOTE: One clamp strap will be with the auger tube, and the other is inside the fill hopper.

9. Connect hydraulic lines (furnished by customer) into ports on side of valve on hydraulic motor. See "Hydraulic Hook-Up Recommendations" in this section.

NOTE: For further operations and adjustment, refer to OPERATIONS section.

Cross Auger For 8 Row Narrow Planters

Except Case I.H. 800/900/950/955/1200/1220/1225, New Holland 480

Before beginning assembly, refer to pre-assembly instructions for all machines.

1. Determine the vertical support tube position required for your particular planter (Fig. 1-6).

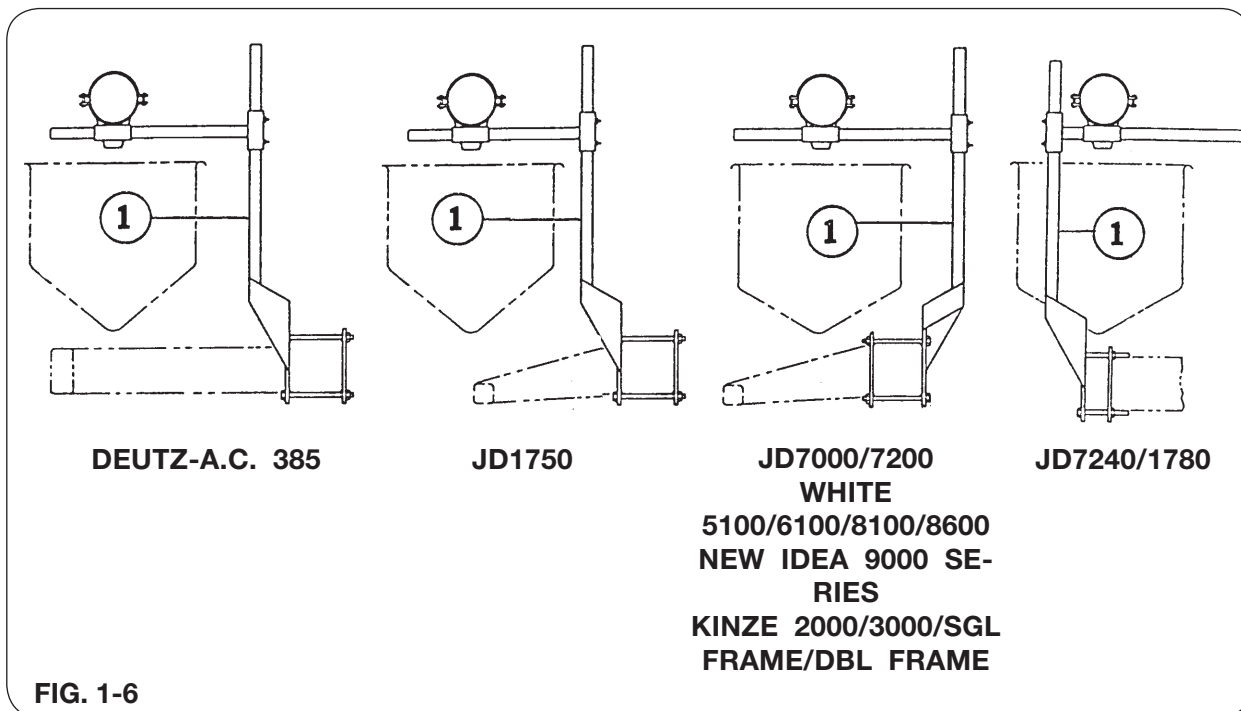

NOTE: On the Kinze 3000 single frame, the arms cannot be mounted in front of the fertilizer boxes on the planter. Arms must be mounted between boxes.

NOTE: On some planters (with certain options and row spacing) it may be necessary to install L.H. vertical support tube onto the planter row unit. To do this, lower planter to the ground, safely block the unit and remove nuts from outside U-bolt on L.H. row unit. Position support tube onto U-bolt (or use bolts and backing plate furnished) reinstall nuts and tighten (Fig. 1-7).

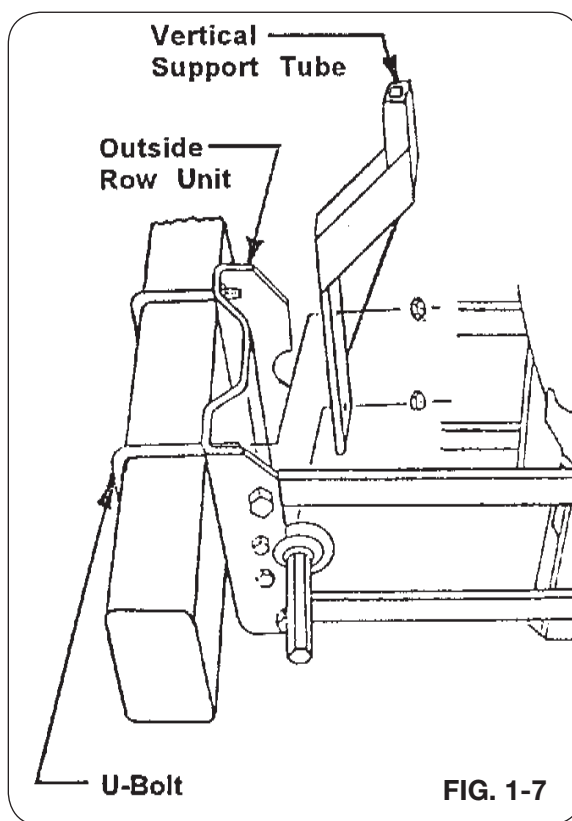

Cross Auger For 8 Row Narrow Planters

Except Case I.H. 800/900/950/955/1200/1220/1225, New Holland 480 (continued)

2. Locate vertical support tubes onto planter main frame (Fig. 1-8). Refer to table for location dimensions.

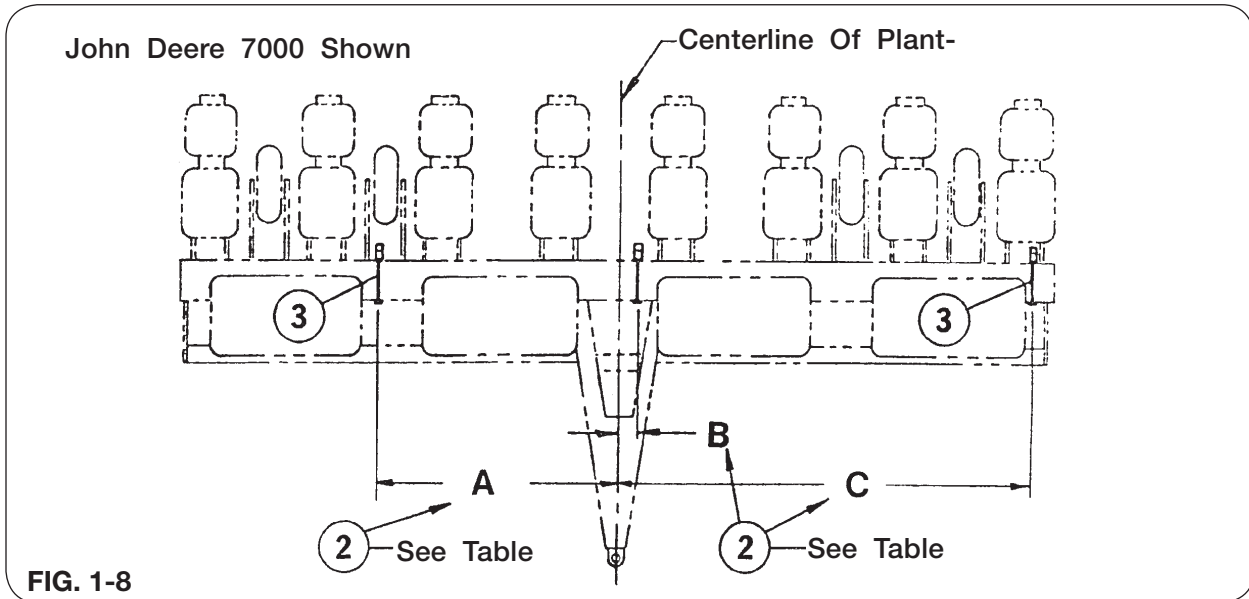

PLANTER	ROW SPACING	"A" DIM.	"B" DIM.	"C" DIM.
DEUTZ-AC	30"	55-70"	0-15"	105-113"
385				
JOHN DEERE	30"	55-65"	0-15"	107-111"
7000				
7200/1750 7240/1780				
NEW IDEA	30"	55-70"	0-15"	105-113"
900/9000 SERIES				
WHITE	30"	55-70"	0-15"	105-113"
5100				
6100 8100				
KINZE	30"	55-65"	0-15"	107-111"
2000/3000 SGL FRAME DBL FRAME				
2500/3500 Twin-Line	30"	55-65"	0-15" Only 2 Arms (Optional)	107-111"

Cross Auger For 8 Row Narrow Planters

Except Case I.H. 800/900/950/955/1200/1220/1225, New Holland 480 (continued)

3. Install vertical support tubes (2003035B) onto planter main frame (Fig. 1-9) using clamp plates (20453), 5/8"-11 x 9 1/2" capscrews (91435), 5/8" lock washers (9404-029), and 5/8"-11 hex nuts (9394-014).
4. Install horizontal support tubes (20355) onto vertical tubes and tighten set screws (Fig. 1-9).

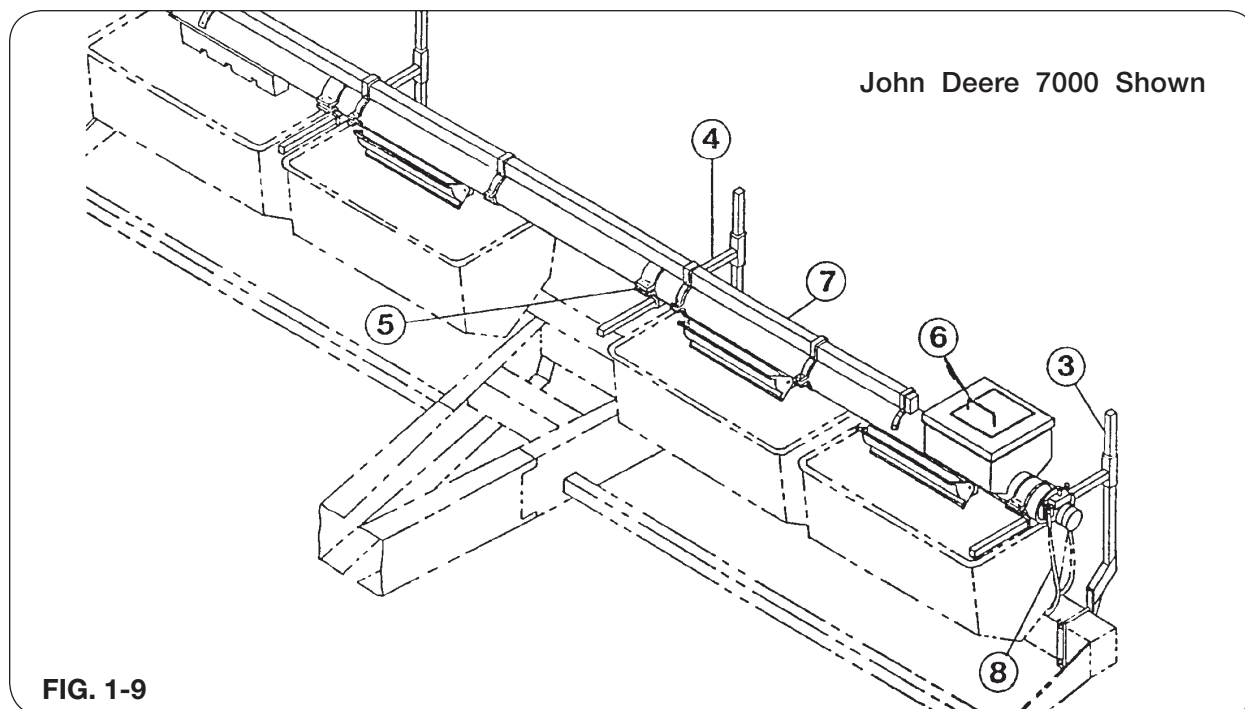

NOTE: For initial set-up position bottom of horizontal tube approximately eight inches above top of fertilizer boxes on planter.

5. Install auger support brackets (20827) onto horizontal support tubes and align with center of fertilizer boxes on planter. Tighten set screws.
6. Reposition handle from shipping position to top of lid.
7. Position cross auger tube assembly onto support brackets and align auger discharge openings over center of planter fertilizer boxes. Retain into position with clamp straps (20819) using 3/8"-16 x 1 1/4" capscrews (9390-056) and 3/8"-16 locknuts (9928).

NOTE: Two clamp straps will be with the auger tube, and the other one is with the mounting bracket bundle.

IMPORTANT

- To insure smooth operation of auger, after clamping auger into position on support brackets, recheck alignment of auger tube, by sighting down the tube to make sure tube is level and straight as positioned in mounting brackets. Adjust mounting brackets if necessary.
8. Connect hydraulic lines (furnished by customer) into ports on side of valve on hydraulic motor. See "Hydraulic Hook-Up Recommendations".

NOTE: For further operations and adjustments, refer to OPERATIONS section.

Cross Auger For 12 Row Narrow Planters JD7000 FRONT-FOLD, JD1770, JD7200 FLEX-FOLD & WHITE 6180/8180 FORWARD FOLD PLANTERS

NOTE: Assembly for R.H. side of planter shown, repeat assembly procedures on L.H. side of planter.

1. Position vertical support tubes onto planter frame. See Fig. 1-10 (and table) for proper placement of support tubes onto planter frame.
2. Position support tube (2003017B) (at center of planter) onto front of planter (7 x 7) wing frame using clamp plate (20727), two 5/8"-11UNC x 10" capscrews (91292), 5/8" lock washers (9404-029), and 5/8"-11UNC hex nuts (9394-014).

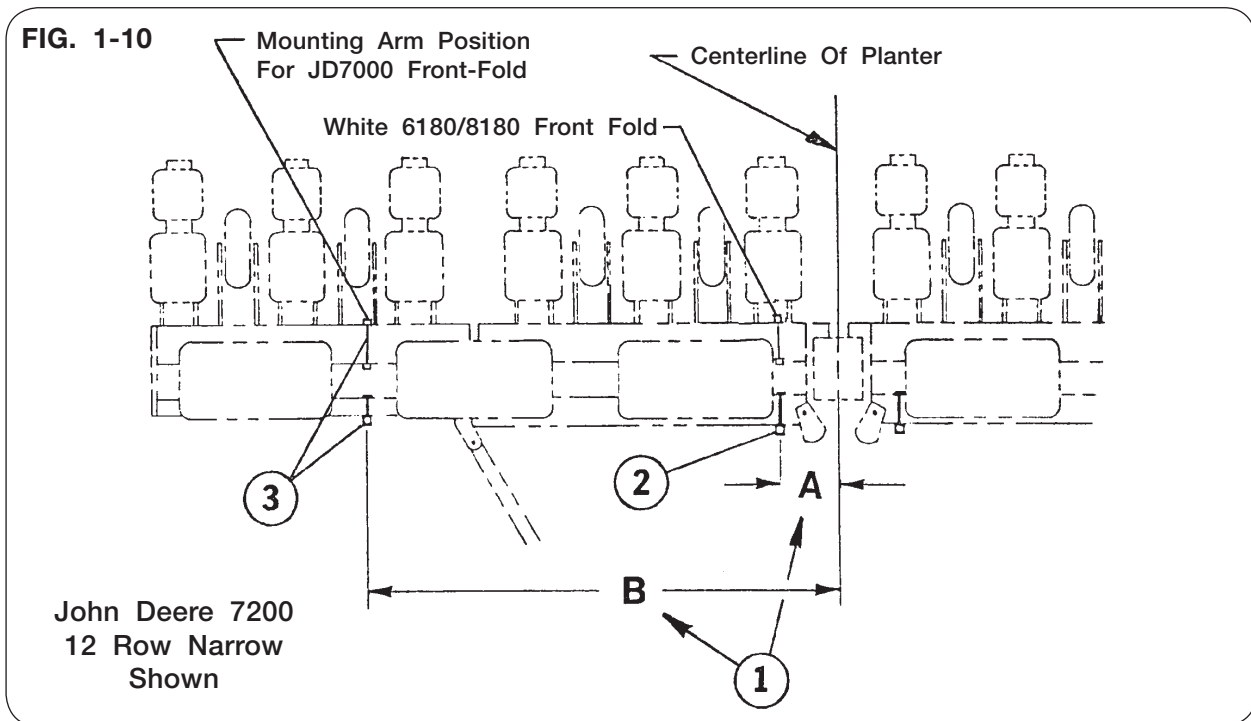

ROWS	ROW SPACING	"A" DIM.	"B" DIM.	PLANTER
12	30"	13-19"	115-130"	JD/1770/7000/7200
12	30"	13-18"	110-130"	WHITE 6180/8180

3. Position the support tube (at outside of planter) onto the front of the planter (3 x 7) wing frame using clamp plate (20727), two 5/8"-11UNC x 9 1/2" capscrews (91435), 5/8" lock washers (9404-029), and 5/8"-11UNC hex nuts (9394-014). See Fig. 1-10 and Fig. 1-11.

Cross Auger For 12 Row Narrow Planters

JD7000 Front-Fold, JD1770, JD7200 Flex-Fold &
White 6180/8180 Forward Fold Planters (continued)

4. Install horizontal support tube (20355) onto vertical tubes and tighten set screws (Fig. 1-11).

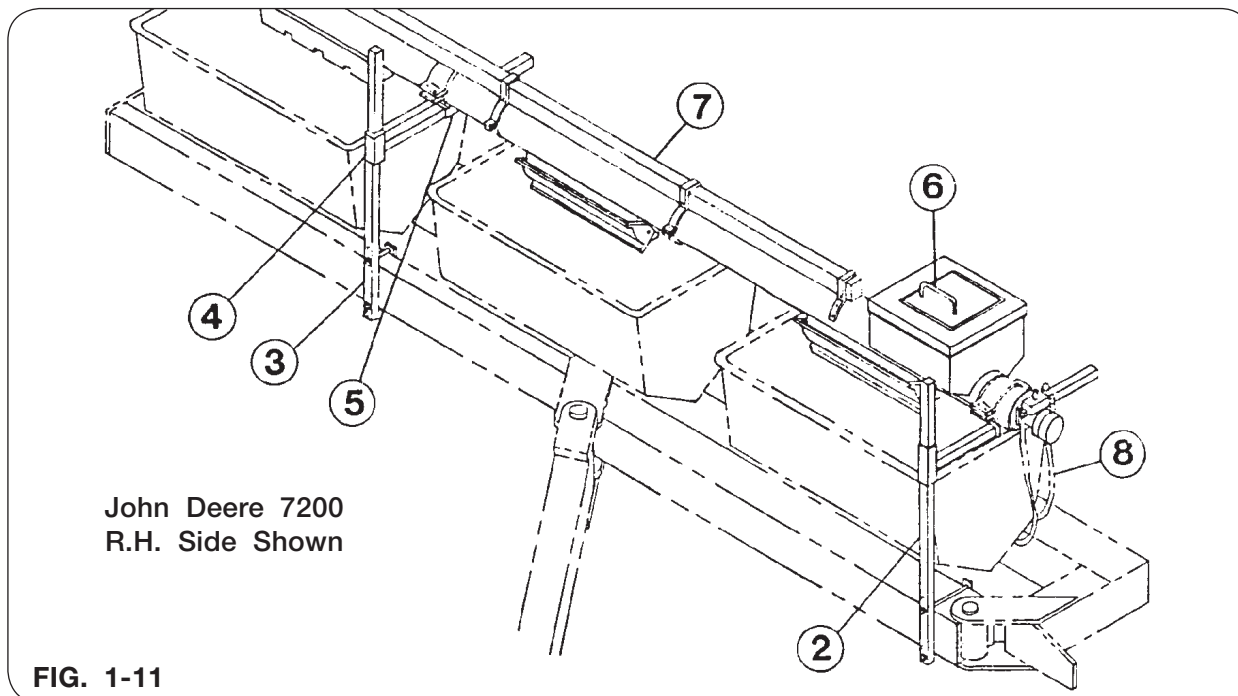

NOTE: For initial set-up position bottom of horizontal tube approximately eight inches above top of fertilizer boxes on planter.

5. Install auger support brackets (20827) onto horizontal support tubes and align with center of fertilizer boxes on planter. Tighten set screws.
6. Reposition handle from shipping position to top of lid.
7. Position cross auger tube assembly onto the support brackets and align the auger discharge openings over center of planter fertilizer boxes. Retain into position with the clamp straps (20819) using 3/8-16 x 1 1/4" capscrews (9390-056) and 3/8-16 locknuts (9928).

NOTE: One clamp strap will be with the auger tube, and the other is with the mounting bracket bundle.

IMPORTANT

- To insure smooth operation of the auger, after clamping auger into position on support brackets, recheck the alignment of the auger tube, by sighting down the tube to make sure the tube is level and straight as positioned in the mounting brackets. Adjust mounting brackets if necessary.
8. Connect the hydraulic lines (furnished by customer) into ports on side of valve on hydraulic motor. See "Hydraulic Hook-Up Recommendations".

NOTE: For further operations and adjustments, refer to OPERATIONS section.

Cross Auger For 16 Row Narrow Planters JD1770, JD7000, JD7200 (16-30 Size)

NOTE: Assembly for right-hand side shown, repeat the assembly procedures on the left-hand side.

Before beginning assembly, refer to pre-assembly instructions for all machines.

1. Position the vertical tubes onto planter frame. See Fig. 1-12 for proper placement of support tubes onto the planter frame.

JD 1770, 7000, 7200 Planter 16 Row 30"
(2 Supports Per Side)

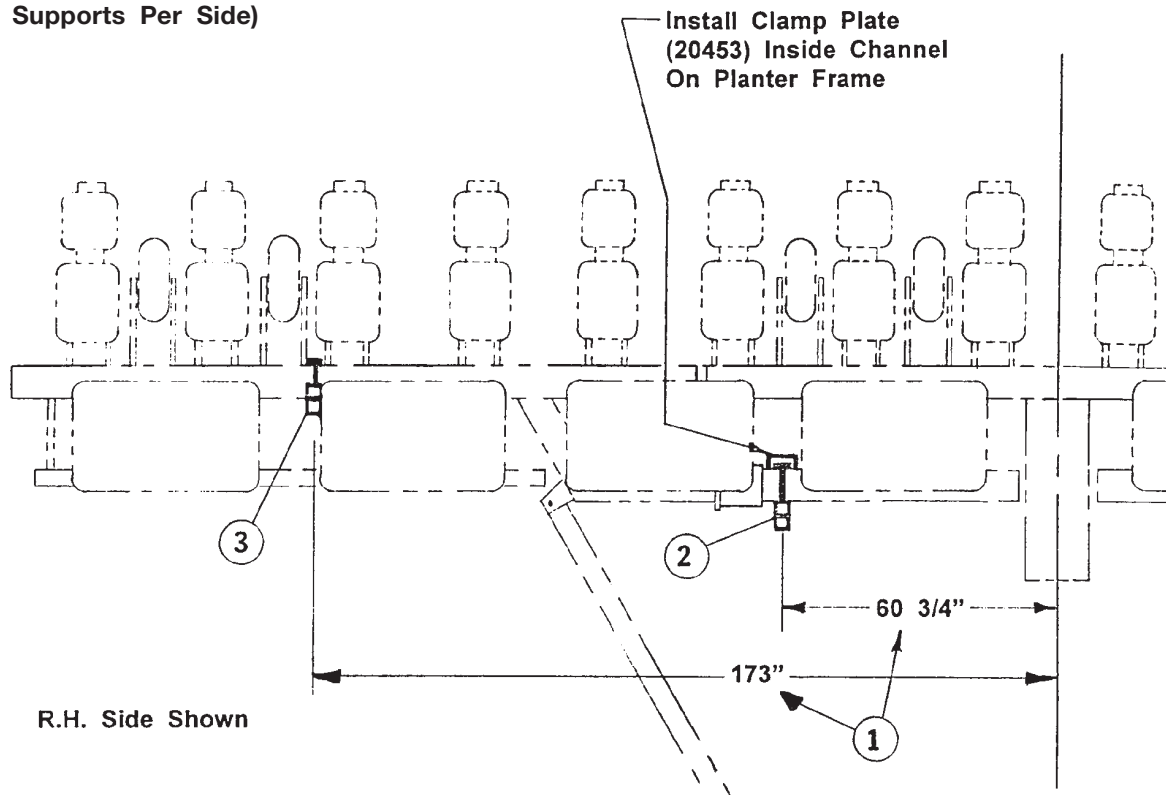
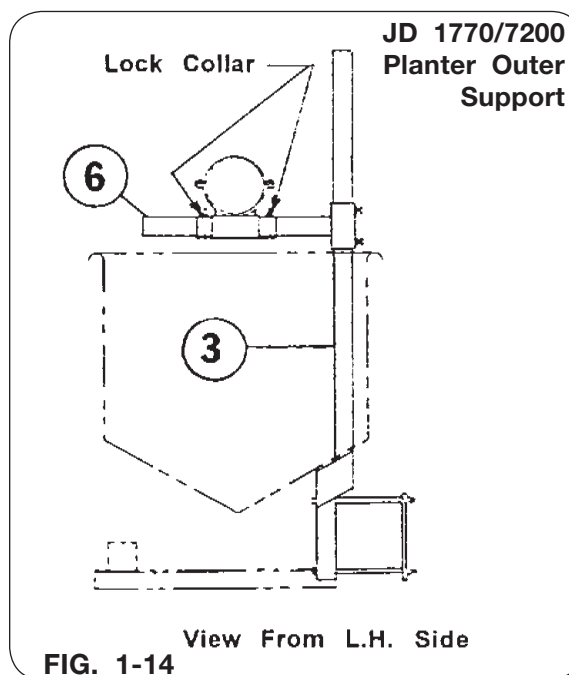
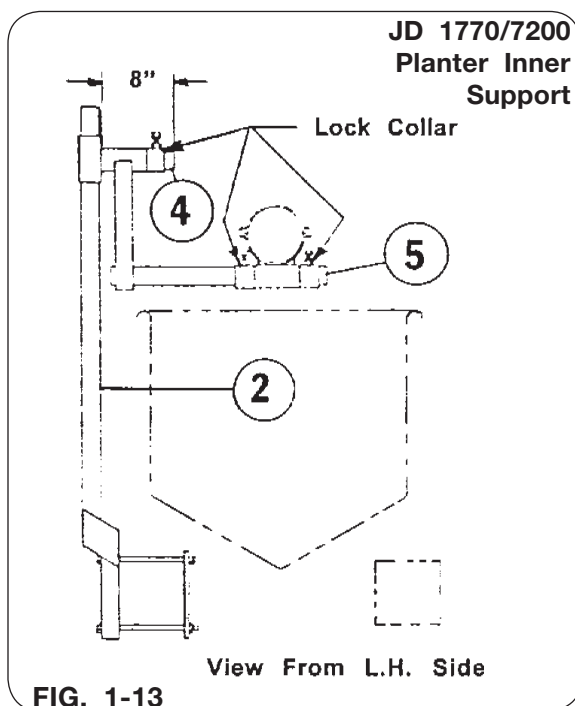

FIG. 1-12

Cross Auger For 16 Row Narrow Planters

JD1770, JD7000, JD7200 (16-30 Size) (continued)

2. Position vertical support tube (2003038B) at center of planter) onto front of planter (7 x 7) main frame (Fig. 1-12 and Fig. 1-13) using clamp plate (20453) two 5/8"-11UNC x 11" capscrews (9390-445), 5/8" lock washers (9404-029), and 5/8"-11UNC hex nuts (9394-014).
3. Position the vertical support tube at the outside of the planter onto the front of the planter (7 x 7) wing frame (Fig. 1-12, Fig. 1-14, and Fig. 1-15) using clamp plate (20453), two 5/8"-11UNC x 11" capscrews (9390-445), and 5/8"-11UNC locknuts (9801).



4. Install 8" long horizontal tube (20970) on the vertical arm at center of the planter (Fig. 1-13). Tighten set screws.
5. Install the pivot arm (20967) onto the 8" horizontal tube (Fig. 1-13). Retain into position with a lock collar (20976).
6. Install the 20" long horizontal tube (20968) onto the vertical arm on the outside of the planter (Fig. 1-14). Tighten set screws.

Cross Auger For 16 Row Narrow Planters

JD1770, JD7000, JD7200 (16-30 Size) (continued)

NOTE: For initial set-up position bottom of horizontal tube approximately eight inches above the top of the fertilizer boxes on the planter.

7. Install the lock collars (20976) and auger support bracket (20827) and align with center of fertilizer boxes on planter. Retain into position with lock collar (20976) (Fig. 1-15). Tighten set screws.

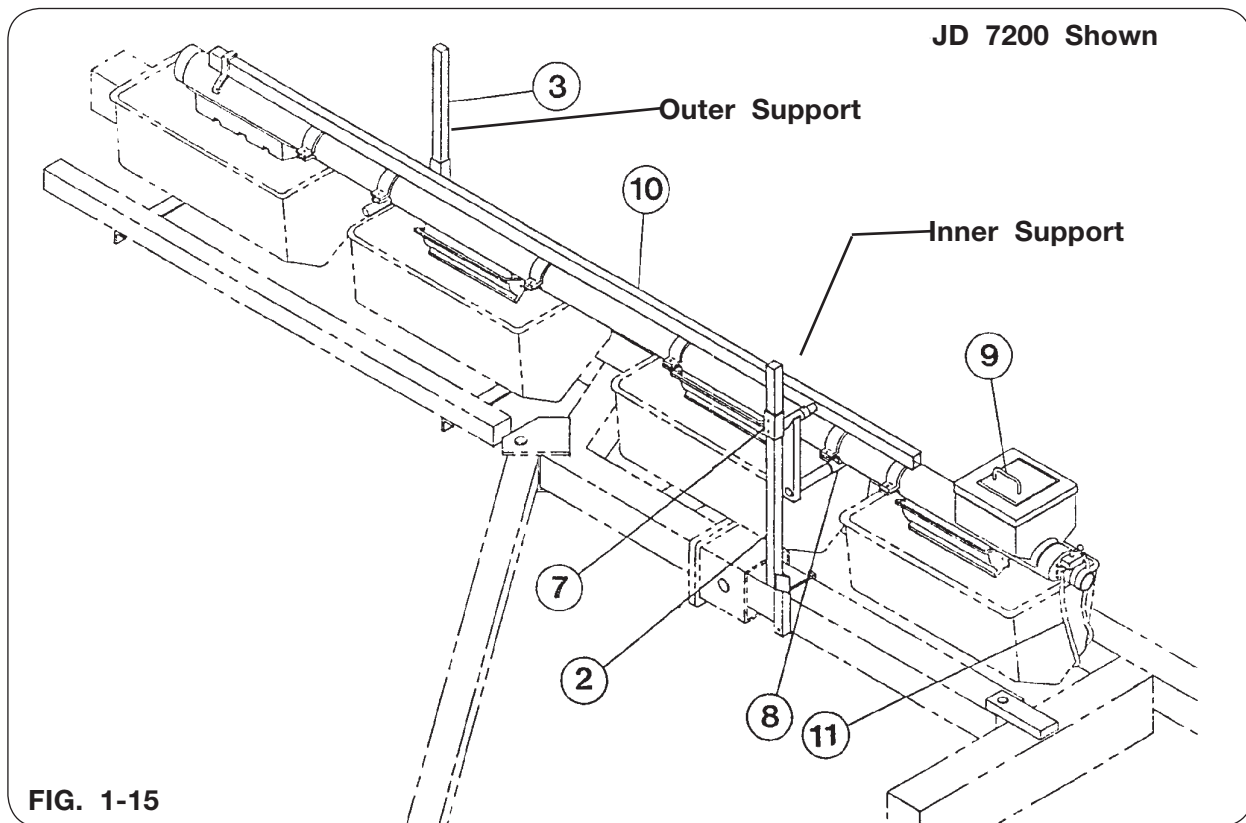

8. Reposition handle from shipping position to top of lid (Fig. 1-15).
9. Position cross auger tube assembly onto support brackets and align auger discharge opening over center of planter fertilizer boxes. Attach to clamp straps on auger using 3/8"-16UNC x 1 1/4" capscrews (9390-056) and 3/8"-16UNC locknuts (9928) (Fig. 1-15).

IMPORTANT

- To insure smooth operation of auger, after clamping auger into position on support brackets, recheck alignment of auger tube, by sighting down the tube to make sure tube is level and straight as positioned in mounting brackets. Adjust mounting brackets if necessary.

10. Connect hydraulic lines (furnished by customer) into ports on side valve on hydraulic motor. See "Hydraulic Hook-Up Recommendations".

NOTE: For further operations and adjustments, refer to OPERATIONS section.

Cross Auger For 16 Row Narrow Planters White 6180/8180

NOTE: Not for 6180/8180 White planters with Tri-fold markers. The markers may interfere with Cross Auger when folding.

NOTE: Assembly for right-hand side of planter shown, repeat the assembly procedures on the left-hand side of planter (Fig. 1-16).

Before beginning assembly, refer to pre-assembly instructions for all machines.

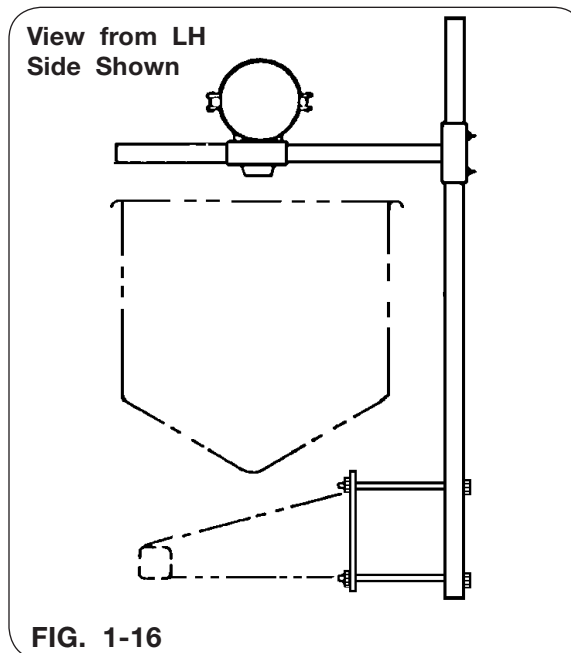

1. Determine the vertical support tube position required for your particular planter (Fig 1-17).

White 6180/8180 Planter 16 Row 30" (3 Supports Per Side)

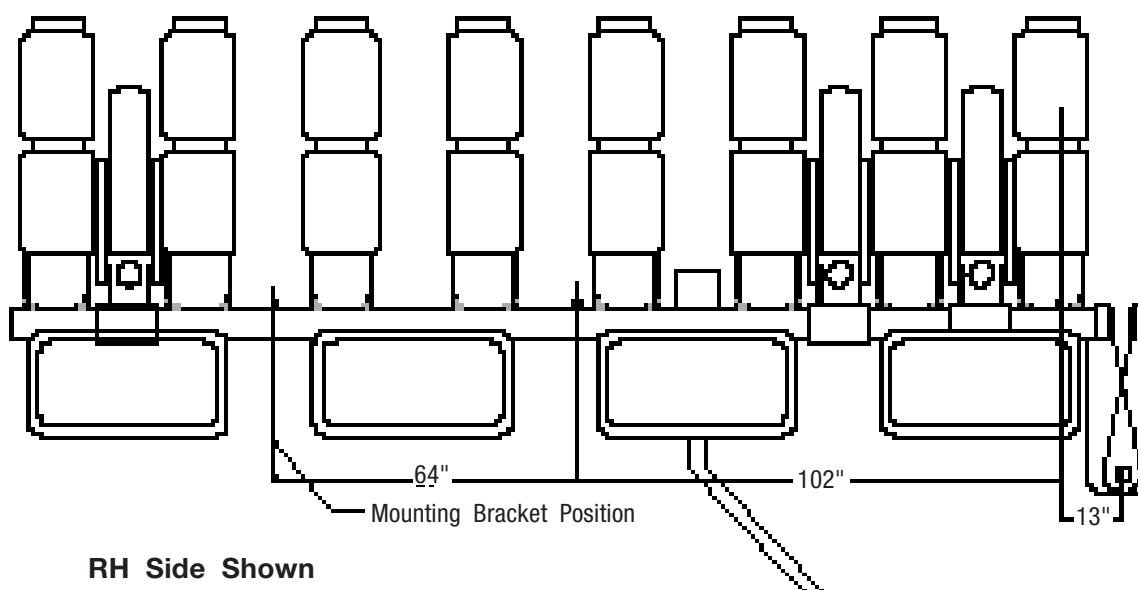
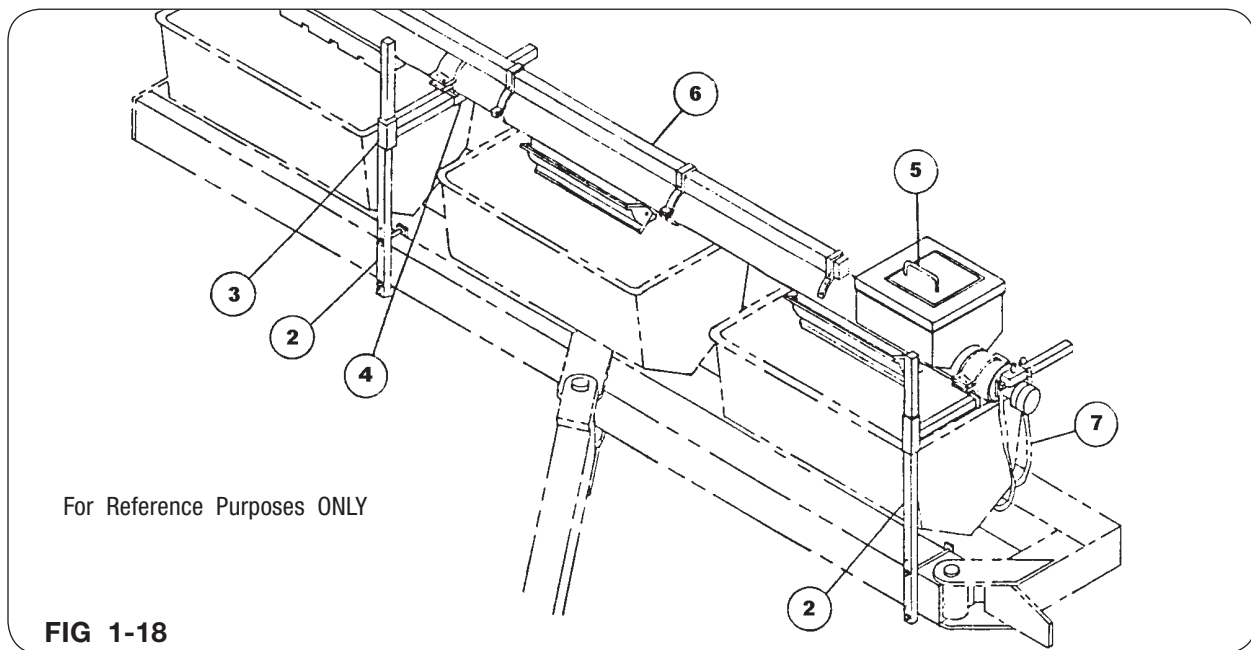

FIG 1-17

OM-00045A

Cross Auger For 16 Row Narrow Planters White 6180/8180 (continued)

2. Install vertical support tubes (2003017B) onto planter main frame (reference Fig 1-18) using clamp plates (20727), 5/8"-11 x 10" capscrews (9390-443), 5/8" lock washers (9404-029), and 5/8"-11 hex nuts (9394-014).
3. Install the horizontal support tubes (20355) onto vertical tubes and tighten set screws (reference Fig. 1-18).



NOTE: For initial set-up position bottom of horizontal tube approximately eight inches above top of fertilizer boxes on planter.

4. Install auger support brackets (20827) onto horizontal support tubes and align with center of fertilizer boxes on planter (reference Fig. 3-18). Tighten set screws.
5. Reposition handle from shipping position to top of lid.
6. Position cross auger tube assembly onto support brackets and align auger discharge openings over center of planter fertilizer boxes. Retain into position with clamp straps (20819) using 3/8"-16 x 1 1/4" capscrews (9390-056) and 3/8"-16 locknuts (9928). Shown similar to Fig 1-16 and Fig. 3-18.

NOTE: Two clamp straps will be with the auger tube, and the other one is with the mounting bracket bundle.

IMPORTANT

- To insure smooth operation of auger, after clamping auger into position on support brackets, recheck alignment of auger tube, by sighting down the tube to make sure tube is level and straight as positioned in mounting brackets. Adjust mounting brackets if necessary.
7. Connect hydraulic lines (furnished by customer) into ports on side of valve on hydraulic motor. See "Hydraulic Hook-Up Recommendations".

NOTE: For further operations and adjustments, refer to OPERATIONS section.

Cross Auger For 6 Row Narrow Planters

Case IH 800/900/950/955/1200/1220/1225, New Holland 480

Before beginning assembly, refer to Pre-Assembly safety instructions on page 2-2.

1. Position vertical support tubes onto planter frame. See Fig. 1-19 for proper placement of support tubes onto planter frame.

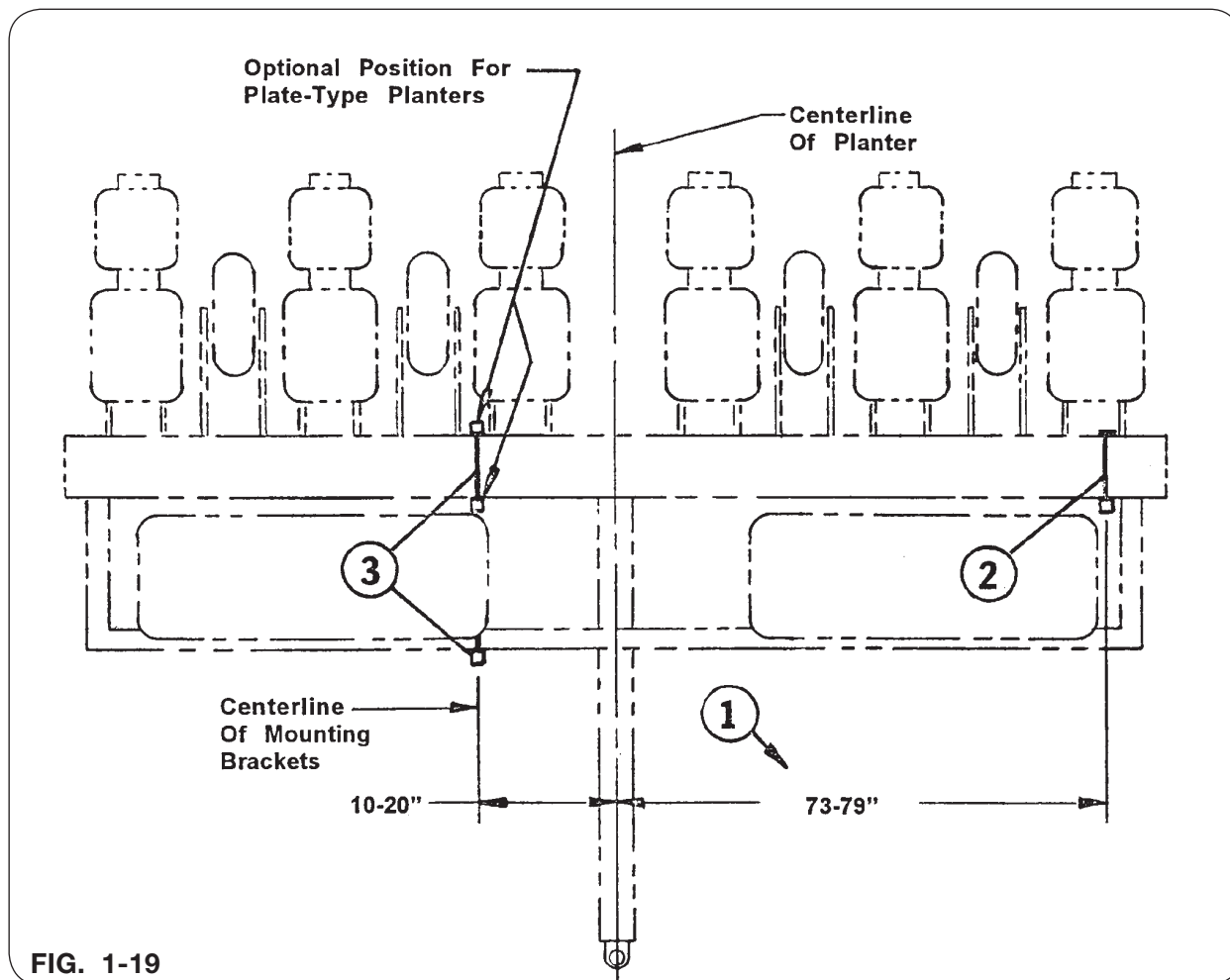

FIG. 1-19

Cross Auger For 6 Row Narrow Planters

Case IH 800/900/950/955/1200/1220/1225, New Holland 480 (continued)

2. Position the vertical support tube (2003017B) on L.H. side of planter main (7 x 7) frame using clamp plate (20727), two 5/8"-11UNC x 10" capscrews (91292), 5/8" lock washers (9404-029), and 5/8"-11UNC hex nuts (9394-014) (Fig. 1-19 and Fig. 1-20).

FIG. 1-20

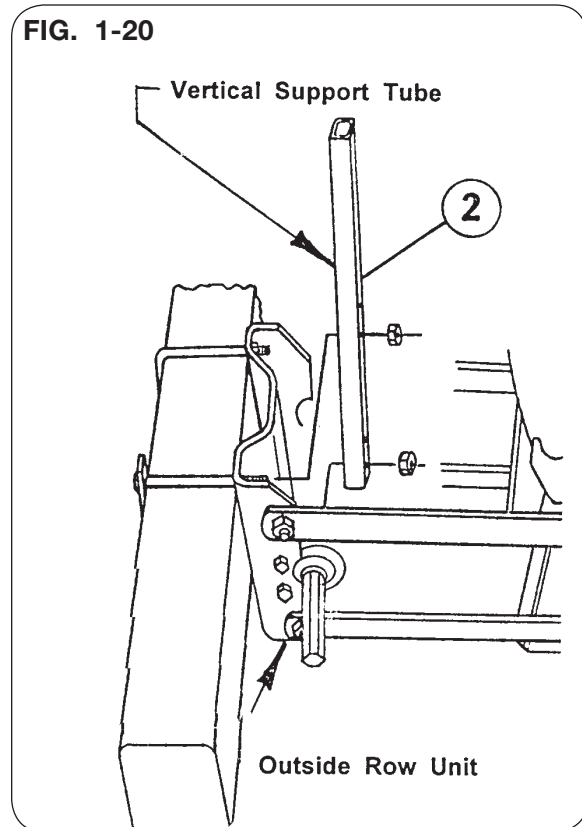

NOTE: ON MODEL 800 PLANTER, the L.H. vertical support tube (2003017B) may be installed onto the planter row unit. To do this, lower planter to the ground, safely block the unit and remove outside U-bolt from L.H. row unit. Replace U-bolt with back plate and 5/8"-11UNC x 10" bolts (furnished). Position vertical support tube onto bolts, installed nuts and retighten.

3. Position vertical support tube (2003017B) onto R.H. side of planter.
 - A. ON AIR-TYPE PLANTERS Position onto fertilizer (2 x 6) bar using clamp plate (20727), two 5/8"-11UNC x 9 1/2" full thd. capscrews (91435), 5/8" lock washers (9404-029), and 5/8"-11UNC hex nuts (9394-014).
 - B. ON PLATE TYPE PLANTERS Position onto main (7 x 7) frame using clamp plate (20727), two 5/8"-11UNC x 10" capscrews (91292), 5/8" lock washers (9404-029), and 5/8"-11UNC hex nuts (9394-014).

Cross Auger For 8 Row Narrow Planter

Case IH 1200/1220/1225, New Holland 480

Before beginning assembly, refer to Pre-Assembly safety instructions on page 2-2.

1. Position vertical support tubes onto planter frame. See Fig 1-19 for proper placement of support tubes onto planter frame.

NOTE: On the 8-30 planter the middle support may be installed in one of two positions (position A or B) on planter frame.

8 Row 30" Size

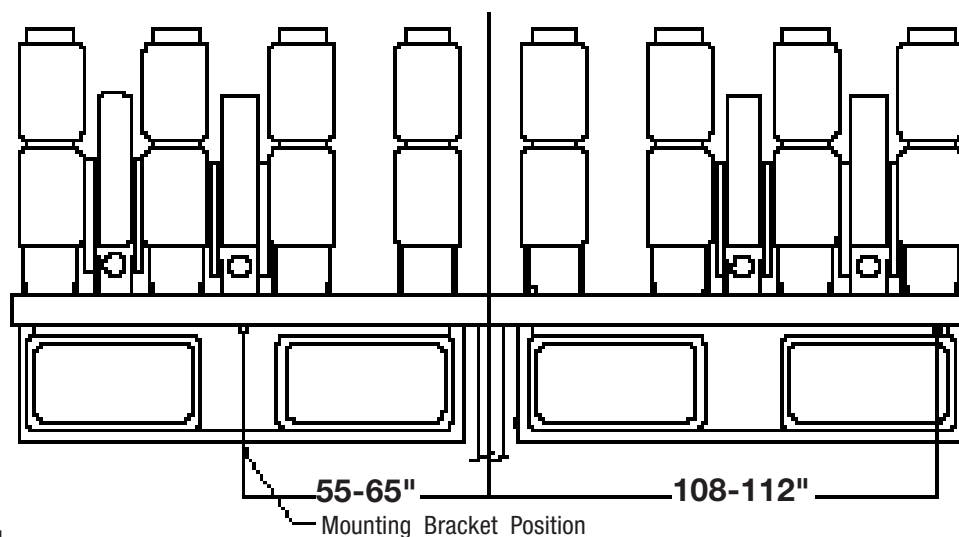

FIG. 1-21

2. Position A: On planter row unit, just left of the tongue (Fig 1-22). To do this, lower planter to the ground and remove outside U-bolt from LH row unit. Replace U-bolt with back plate and 5/8"-11 x 10" bolts (furnished). Position the vertical support tube onto bolts, install nuts and retighten (Fig. 1-22).

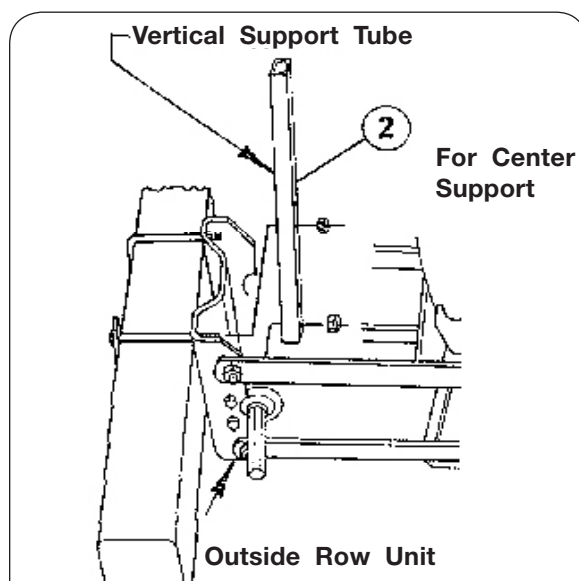
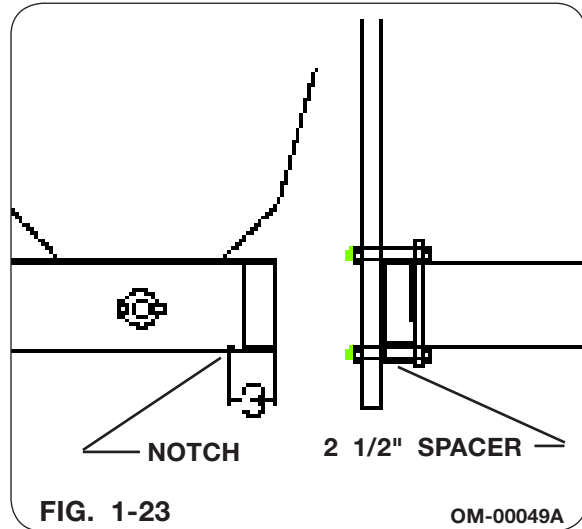

FIG. 1-22

JM-00051

Cross Auger For 8 Row Narrow Planter Case IH 1200/1220/1225, New Holland 480 (continued)

3. Position B: On the front to rear fertilizer drive shaft support, left of the tongue. To mount in this position use a grinder to cut a raised notch in the long leg of the front to back support (Fig 1-23). Clamp support into place with two 5/8" -11 x 5" capscrew (9390-134) plate (20727) and spacer (23427). Retain into place with 5/8" lock washer (9404-029) and Hex nut (9394-014).



4. Install horizontal support tubes (20355) onto vertical tubes and tighten set screws (Fig. 1-24).

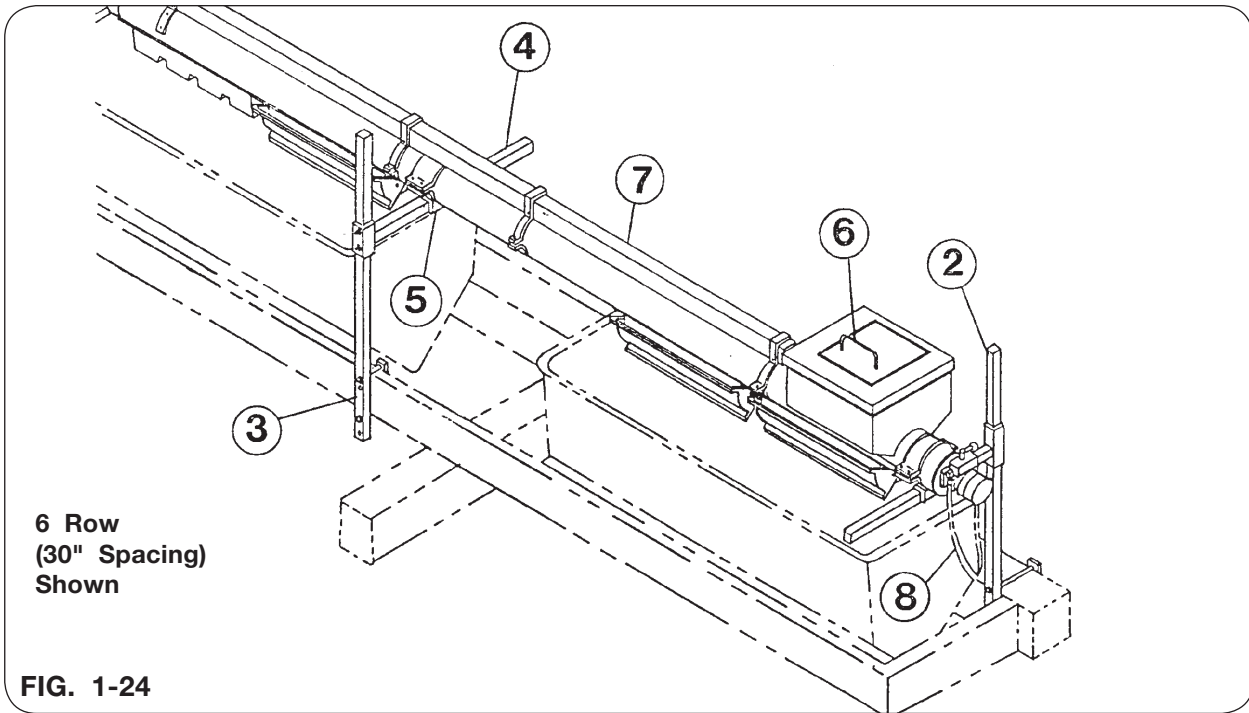

Cross Auger For 8 Row Narrow Planter Case IH 1200/1220/1225, New Holland 480 (continued)

NOTE: For initial set-up position bottom of horizontal tube approximately eight inches above top of fertilizer boxes on planter.

5. Install auger support brackets (20827) onto horizontal support tubes and align with center of fertilizer boxes on planter (Fig. 1-24). Tighten set screws.
6. Reposition handle from shipping position to top of lid.
7. Position cross auger tube assembly onto support brackets and align auger discharge openings over center of planter fertilizer boxes. Retain into position with clamp straps (20819) using 3/8"-16 x 1 1/4" capscrews (9390-056) and 3/8"-16 locknuts (9928) (Fig. 1-24).

NOTE: Two clamp straps will be with the auger tube, and the other one is with the mounting bracket bundle.

IMPORTANT

- *To insure smooth operation of auger, after clamping auger into position on support brackets, recheck alignment of auger tube, by sighting down the tube to make sure tube is level and straight as positioned in mounting brackets. Adjust mounting brackets if necessary.*
8. Connect hydraulic lines (furnished by customer) into ports on side of valve on hydraulic motor. See "Hydraulic Hook-Up Recommendations".

NOTE: For further operations and adjustments, refer to OPERATIONS section.

Hydraulic Hook-Up Recommendations

ABOUT YOUR AUGER HYDRAULICS:

The hydraulic control is designed to give the user convenient on/off hand control at the motor.

The open center spool (on the cross auger hydraulic control valve), allows the auger to be used with either an "open center" or "closed center" tractor hydraulic system.

The system is designed to allow the motor to only run in a forward direction, preventing accidental jam-up of fertilizer at motor end of tube.

WARNING

- **RELIEVE PRESSURE BEFORE DISCONNECTING THE HYDRAULIC LINES FROM THE TRACTOR, LOOSENING ANY HYDRAULIC FITTINGS OR SERVICING THE HYDRAULIC SYSTEM. SEE THE HYDRAULIC POWER UNIT MANUAL FOR THE PROCEDURE TO RELIEVE PRESSURE.**

- **USE A PIECE OF CARDBOARD OR WOOD TO DETECT LEAKS OF HYDRAULIC FLUID UNDER PRESSURE. CORRECT HYDRAULIC LEAKS IMMEDIATELY.**

- **HIGH-PRESSURE FLUIDS CAN PENETRATE THE SKIN AND CAUSE SERIOUS INJURY OR DEATH. SEEK MEDICAL TREATMENT IMMEDIATELY IF INJURED BY HIGH-PRESSURE FLUIDS.**

- **DO NOT BEND OR STRIKE HIGH-PRESSURE LINES. DO NOT INSTALL BENT OR DAMAGED TUBES OR HOSES.**

- **REPAIR ALL OIL LEAKS. LEAKS CAN CAUSE FIRES, PERSONAL INJURY AND ENVIRONMENTAL DAMAGE.**

- **ROUTE HOSES AND LINES CAREFULLY TO PREVENT PREMATURE FAILURE DUE TO KINKING AND RUBBING AGAINST OTHER PARTS. MAKE SURE THAT ALL CLAMPS, GUARDS AND SHIELDS ARE INSTALLED CORRECTLY.**

Hydraulic Hook-Up Recommendations (continued)

Check Valve

IMPORTANT

- Check valve (91296) is supplied with the auger and must be in place to prevent motor from running backwards.

Before connecting hydraulic lines to the control valve, be sure the check valve is in position as shown in Fig. 1-25.

IMPORTANT

- For optimum performance and maximum life from your CROSS AUGER, set the tractor flow to the 8 to 12 GPM range. If your tractor cannot be adjusted to this range a flow control valve (21125) can be ordered through your Unverferth dealer.

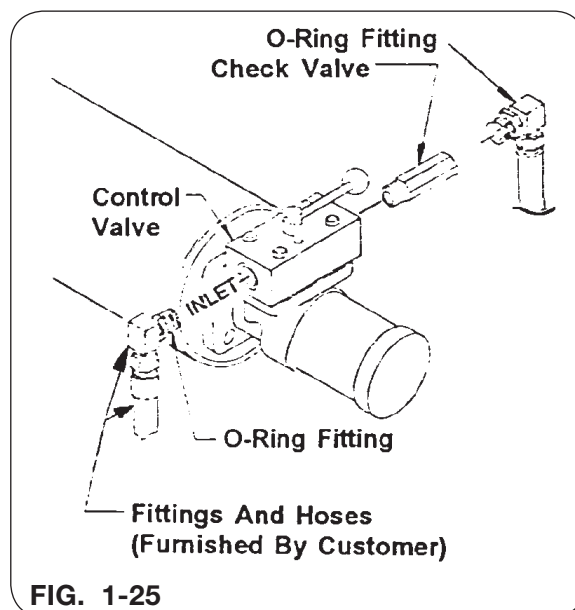

System Capacity Requirements:

FLOW	8 to 12 GPM
PRESSURE	1000 PSI Minimum; 2000 PSI Maximum

NOTE: Protect cross auger components when exceeding 2000 PSI by purchasing pressure relief valve kit #23467

When installing the hydraulic lines, it is recommended that the cross auger hydraulics be connected into a separate two way hydraulic control circuit. However, if no other control circuit is available, the cross auger hydraulics may be connected into an existing circuit by using a manual selector valve (91280), available through you Unverferth dealer.

Install Hydraulic Lines as Follows:

1. Lower planter to the ground and relieve all hydraulic pressure from the planter circuits.
2. (Selector Valve System Only) Secure valve at convenient place, and connect into existing circuit.
3. Connect lines to cross auger control valve and route to selector valve or tractor.
4. Tighten all connections, check for kinks or twist.
5. Secure lines onto planter frame.

NOTE: TO OPERATE CROSS AUGER WITH SELECTOR VALVE SYSTEM, first lower the planter to the ground. Position the selector valve to cross auger circuit and start flow of oil to cross auger. (Use on/off control at motor to start and stop auger rotation) after completing auger operation, stop flow of oil from tractor, and reposition selector valve to planter circuit.

Hydraulic Hook-Up Recommendations (continued)

The hydraulics for the 12 row and 16 row cross augers use 2 motors for planter fill. For optimum performance and maximum life, set tractor flow at 8-12 GPM range. When installing hydraulic lines, it is recommended auger motors be connected in series (Fig 3). Plumbing the auger this way allows the operator to operate one or both augers at the same time. The completed circuit should be connected to remote outlets on the tractor.

NOTE: It is not recommended that the auger be operated empty for extended periods of time. Damage to the auger could occur.

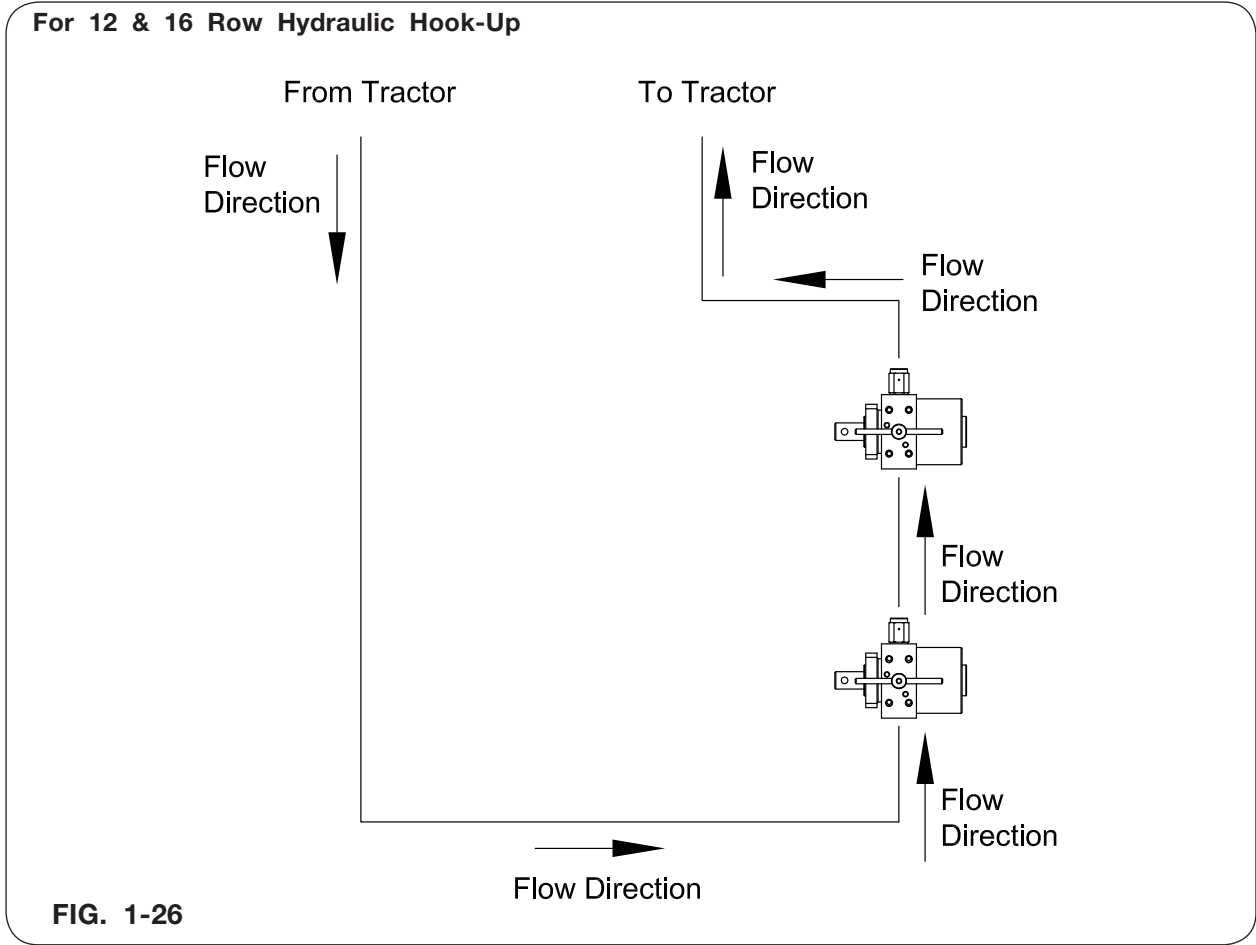

Optional Speed Control Valve Package #21125

Tractors having high-capacity hydraulic systems with 12 to 35 GPM flow, will cause your cross auger to run too fast, resulting in:

- A. Excess Vibration
- B. Excess Wear
- C. Loss of Performance

To eliminate these problems, an adjustable flow control valve package #21125 is being offered for installation into the auger hydraulic system. This valve will allow the operator to adjust the flow to obtain the recommended cross auger operating speed of 400 to 600 RPM.

NOTE: The speed control valve may be ordered through your Unverferth dealer.

1. To install control valve, follow appropriate plumbing diagram (Fig. 1) for open-center hydraulic system or (Fig. 2) for closed-center hydraulic system. Contact your local dealer to identify which system your tractor is equipped with.

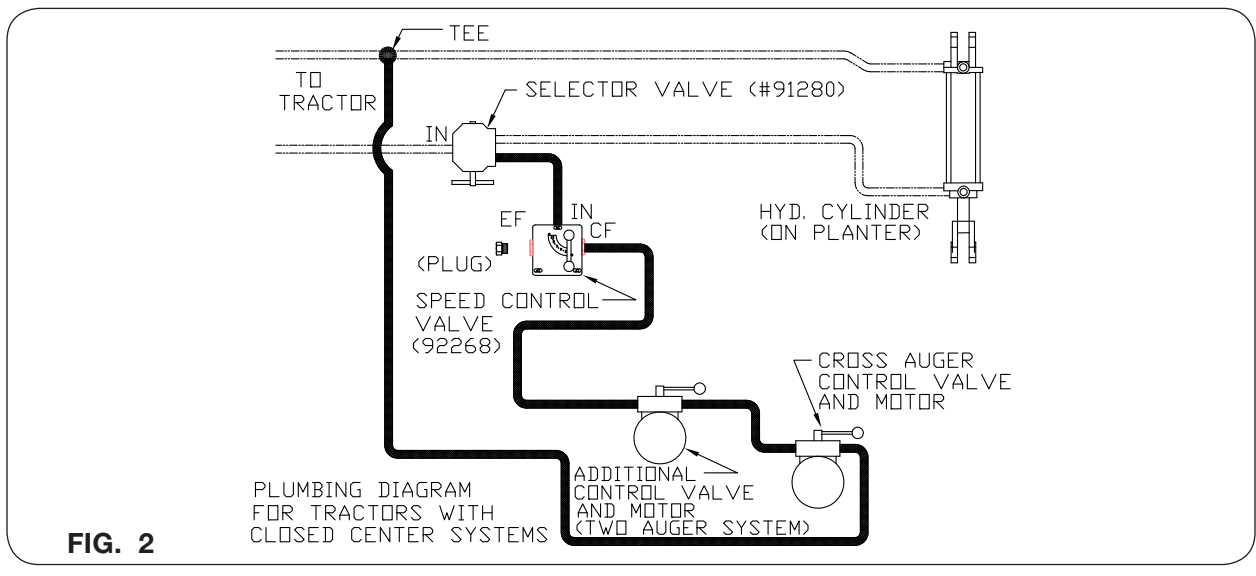
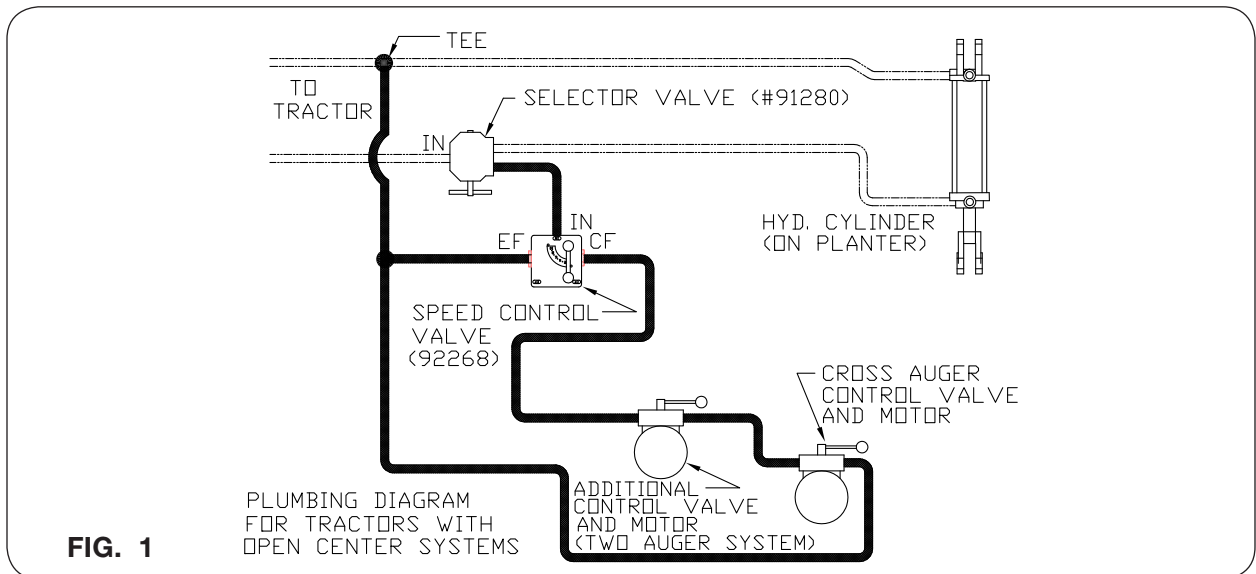

Optional Speed Control Valve Package #21125 (continued)

2. Once the control valve is installed, the cross auger speed can be set as follows:
 - A. Set flow control valve approximately 1/2 way on flow indicator (lock into position).
 - B. Start oil flow and run auger to check auger speed. Flighting should run smooth, not lag or fluctuate in speed, adjust speed control valve if necessary

NOTE: When cross auger is loaded with material, auger should not stall. Adjust speed to allow for smooth even feeding of material through tube.

Relief Valve Bundle #23647 (Optional)

This unit will allow excessive hydraulic pressure to bypass the motor to prevent damage.

⚠ WARNING

- BEFORE DISCONNECTING AUGER HYDRAULICS, BE SURE THAT ALL PRESSURE IS RELIEVED. FAILURE TO DO SO COULD RESULT IN INJECTION OF HYDRAULIC FLUID INTO SKIN OR EYES. THIS COULD RESULT IN INFECTION OR IN SOME CASES DEATH.

⚠ CAUTION

- BEFORE INSTALLATION CAN BEGIN, BE SURE THAT THE AUGER AND IMPLEMENT IT IS INSTALLED ON IS SECURELY BLOCKED TO PREVENT MOVEMENT. THIS WILL PROVIDE A SAFE WORKING ENVIRONMENT.

NOTE: Be sure to disconnect hydraulics while working in an environment clean of dirt and debris. If dirt should enter into system, flush system. Failure to remove dirt could result in motor failure or damage to system supply.

1. Disconnect hoses at motor end.
2. Before installing the relief valve determine whether your flight is right-handed or left-handed. View the auger from the hopper end, if the flight turns clockwise it is left-handed. Right-handed flight turns counter clockwise.
3. Once the flight direction is known, position the relief valve as follows: For right-handed flights the in-port ("A") goes to the left-side of the motor. Again, look from the hopper end or the shaft end of the motor. For left-handed flights, the in-port ("A") goes to right side of motor. Fig. 1 & 2 show left-hand flight.
4. Apply an SAE approved sealant and connect relief valve, adapters, tee, and hose to hydraulic lines as shown (Fig. 2).

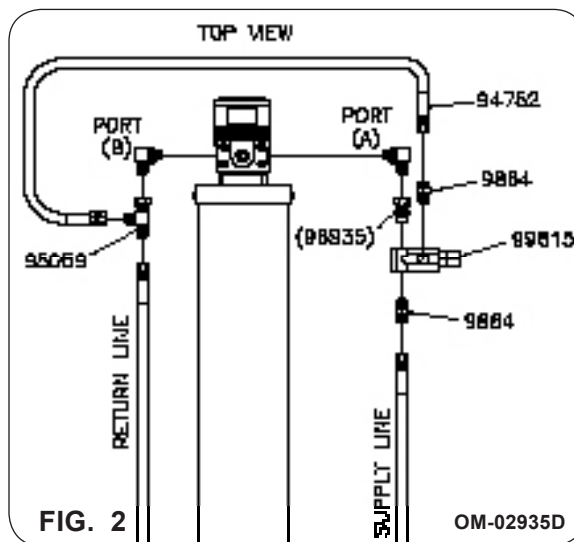
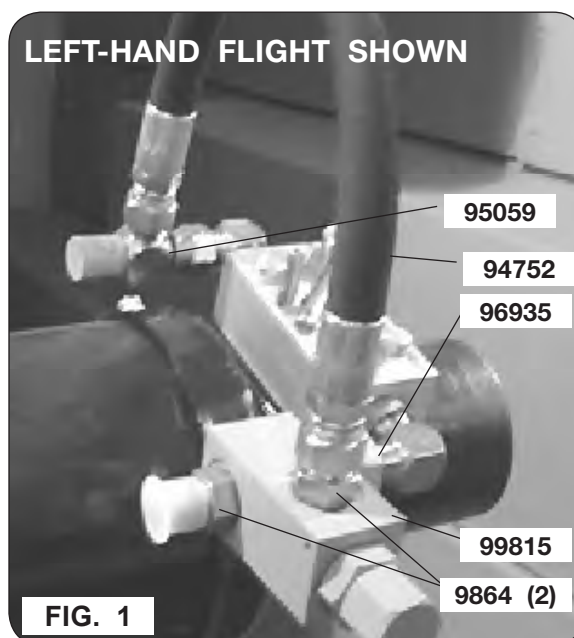

SECTION III

Operation

Hydraulic Hook-Up	3-2
Auger Operation.....	3-2
Filling Planter.....	3-2
Shut-Off Flow to Planter.....	3-3
Adjusting Shut-Off Door	3-3
Performance	3-4
Transporting.....	3-4

Hydraulic Hook-Up

See assembly section "Hydraulic Hook-Up Recommendations" before installing hydraulic lines between tractor and CROSS AUGER.

WARNING

- **HIGH-PRESSURE FLUIDS CAN PENETRATE THE SKIN AND CAUSE SERIOUS INJURY OR DEATH. SEEK MEDICAL TREATMENT IMMEDIATELY IF INJURED BY HIGH-PRESSURE FLUIDS. USE CARDBOARD OR WOOD TO DETECT LEAKS IN THE HYDRAULIC SYSTEM.**

After mounting and making all necessary connections between tractor and auger, check the following:

Make sure all hoses are properly routed and secured into position to prevent pinching or binding.

Make sure all connections are properly tightened to prevent leaks.

Auger Operation

Engage tractor hydraulic system to start supply of hydraulic oil flowing to CROSS AUGER and operate selector valve to make sure auger flighting is rotating in a forward direction (counter-clockwise when looking from motor end of auger tube).

NOTE: Check valve fitting (located next to control valve) should only allow flighting to rotate in a forward direction. If flighting will only turn in a backwards direction reposition check valve, as shown in hydraulic hook-up recommendations (page 2-23).

Filling Planter

For initial set-up, position bottom of drops (on CROSS AUGER) approximately 2" above top of fertilizer hoppers on planter.

IMPORTANT

- *To insure smooth operation of auger, after installing auger into position onto support brackets, recheck alignment of auger tube, by sighting down tube to make sure tube is level and straight as positioned in mounting brackets. Adjusting mounting brackets if necessary.*

Auger Operation

Remove planter fertilizer hopper lids and position transfer auger spout into CROSS AUGER hopper. Start both augers rotating and begin flow of fertilizer into auger. Adjust feed of material through augers. Fill planter hoppers completely and shut-off augers before leveling fertilizer in planter hoppers.

⚠ WARNING

- **MOVING OR ROTATING COMPONENTS CAN CAUSE SERIOUS INJURY OR DEATH. ENSURE SERVICE COVERS, CHAIN/BELT COVERS AND CLEAN-OUT DOOR ARE IN PLACE AND SECURELY FASTENED BEFORE OPERATING**

A little practice will show user how to combine functions of varying auger vertical height, and rate of flow for best results when filling planter fertilizer hoppers.

Shut-Off Flow To Planter Hoppers

Shut-off doors (Fig. 2) are furnished to allow the user to fill his planter hoppers partially full. When desired level of fertilizer is reached, move shut-off door to the closed position (repeat as necessary, stop flow of fertilizer in auger to limit amount in last hopper).

IMPORTANT

- *Empty auger before moving.*

Adjusting Shut-Off Door

Periodic adjustment may be required to keep proper tension on shut-off doors. Tighten door mounting screws, (on each end of auger drops) to increase tension, allowing the door to be held in the open position yet still able to be closed, using slight hand pressure.

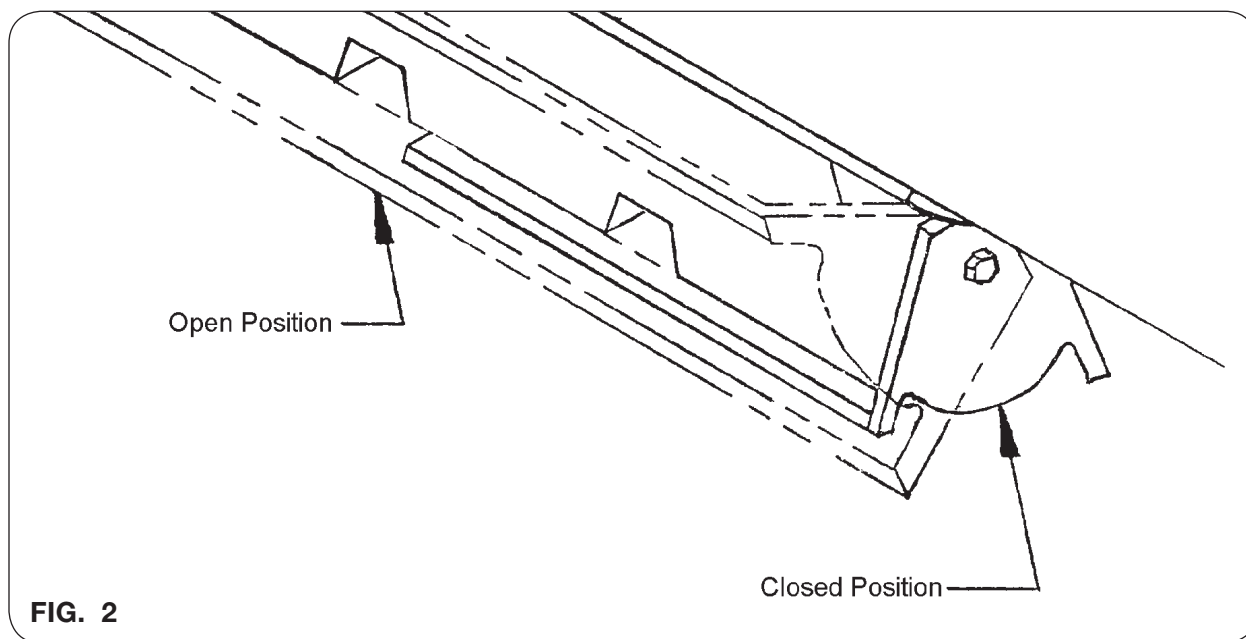

Performance

SPECIAL NOTE: Many augers are run too fast. This is usually the result of modern tractors with hydraulic systems providing high flow (12 to 32 gpm) at the accessory outlets. When adjustment is provided, the flow should be reduced to 8 to 12 gpm. The lower flow rates will result in optimum performance of the auger, produce less harm to the material handled, and provide longer wear life of the flighting.

When the auger speed is too fast, it may cause severe vibration, damage or premature wear of flighting and tube. This excessive speed may cause damage to auger while the rate of discharge could actually be reduced.

Transporting

NOTE: Auger should be emptied before moving.

SECTION IV

Maintenance

General Maintenance.....4-2

Lubrication.....4-2

Troubleshooting

- Auger Will Not Turn Over or Develop Proper Speed/Torque.....4-3
- Auger Runs Too Slow4-3
- Auger is Turning in Wrong Direction4-4
- Oil Heat Excessively.....4-4
- Pump/Motors/Seals Blow - Shaft/Housing Breaks - Hose Burst.....4-4

General Maintenance

Flush and clean auger tube and hopper periodically after use.

Check:

- Valve, motor, hoses, and fittings for leaks, etc.
- All bolts for tightness. This is especially important during the first days of operation.

Lubrication

Lubricate with an SAE multi-purpose grease. All fittings must be free from dirt and paint to insure entry of lubricant inside bearing.

Flighting End Bearing

Lubricate bearing every 100 hours of operation and at the end of each season, before storage. Use only one stroke of grease per bearing.

IMPORTANT

- *Do not use a high-pressure grease gun to lubricate bearings, as damage to the bearing seal could occur.*

NOTE: Excessive lubrication of these bearings will result in premature failure.

Troubleshooting

Occasionally when an auger has been connected into an auxiliary hydraulic system, it may not operate or auger the material being handled. When hydraulic pressure and flow gauges are not available, it may be difficult to determine if there is a fault in the source, hydraulic system, or the auger. A convenient method of determining this is to connect the auger hydraulic hoses to another tractor system and check the operation. If, for example, the auger operates from the other tractor system but not from the original tractor there is a fault in the original tractor connection, or the original tractor system is not adequate. If the auger fails to operate; however, there is probably a fault with the auger control valve, motor, or the auger itself. In this case, refer to the trouble shooting guide.

PROBABLE CAUSE	CORRECTION
Auger Will Not Turn Over or Develop Proper Speed/Torque	
Pump does not deliver sufficient pressure or volume	Check output and delivery-repair if necessary
Auger mechanism binding	Check for cause and correct
Wrong hose hook-up to tractor control levers	Refer to Tractor Operator's Manual for valve and control lever arrangement
Insufficient tractor hydraulic pressure	See the following: A. Check hydraulic reservoir oil level B. See assembly section "Hydraulic Hook-Up Recommendations"
Hydraulic components leaking oil	Find cause and correct
Hydraulic hoses kinked or twisted	Find cause and correct
Malfunction of hydraulic components	Isolate problem area-repair as necessary
Auger Runs Too Slow	
Pump is worn	Repair or replace pump
Internal leak in controls or motor	Replace seals; repair or replace valves or motors
Air in system	Bleed system and tighten connections
If auger starts slowly and speed increases after oil heats up; oil is too heavy weight. If auger slows down after oil heats up; oil is too light weight	Use proper weight hydraulic oil

Trouble Shooting (continued)

PROBABLE CAUSE

CORRECTION

Auger is Turning in Wrong Direction

Incorrect piping between source and control valve

Reverse piping connections

Improperly installed check valve plate

Reposition (As shown in SET-UP section)

Oil Heat Excessively

Too light weight in hot climate

Drain and refill with proper weight oil.

Oil too heavy weight

Use recommended weight oil.

Dirty oil

Drain, flush, and refill with clean oil and filter

Oil level too low

Fill to proper level

Relief valve pressure too high or low; does not operate

Adjust and repair or replace relief valve

Oil slipping through worn pump

Repair or replace pump

Hoses or valves too small

Use larger hoses or valves

Restricted lines or piping

Reroute lines to eliminate restrictions

Reservoir too small to provide adequate cooling

Replace with larger reservoir or install oil cooler

Pump/Motors/Seals Blow - Shaft/Housing Breaks - Hose Burst

When a standard control valve is returned to neutral to stop or start a motor, sudden excess pressure is created which will break seals, tear off motor shafts, burst housing or hoses, (Especially at speed under load.) This sudden shock cannot be relieved through the primary relief valve in the system.

Avoid sudden rapid starting and stopping

SECTION V

Parts

Mounting Bracket Components	
For 6 & 8 Row Narrow Planters.....	5-2
Mounting Bracket Components	
For 6 & 8 Row Narrow Kinze 2500/3500 Planters.....	5-3
Mounting Bracket Components	
For 12 Row Narrow Planters	
John Deere 7000, John Deere 1770, John Deere 7200 Forward Fold,	
& White 6180/8180 Forward Fold	5-4
Mounting Bracket Components	
For 16 Row Narrow Planters	
John Deere 1770, John Deere 7200 Flex Fold	
& White 6180/8180 Forward Fold	5-5
Motor/Valve/Motor Mounting End Cap	5-6
Molded Part, Hardware, & Decals	5-8
Auger Tube & Flighting	
For 6 Row Narrow Planters.....	5-10
For 8 Row Narrow Planters.....	5-11
For 12 Row Narrow Planters.....	5-12
For 16 Row Narrow Planters.....	5-13
Stiffener Brace/Clamps.....	5-14
End Bearing and Shaft Components	5-15
Control Valve Package #21125 (Optional)	5-16
Relief Valve Bundle #23647 (Optional).....	5-16
Valve/3-Way Selector #91280 (Optional)	5-17

CROSS AUGER — Parts

Mounting Brackets — For 6 Row / 8 Row Narrow Planters

ITEM	PART NO.	DESCRIPTION
1	20355	Tube Weldment
2	2003017B	Tube
3	20727	Plate
4	20819	Clamp
5	20827	Strap Weldment
6	91235	Set Screw 1/2-13UNC x 1
7	9390-443	Capscrew 5/8-11UNC x 10
8	91435	Capscrew 5/8-11UNC x 9 1/2
9	9390-056	Capscrew 3/8-16UNC x 1 1/4
10	9390-134	Capscrew 5/8-11UNC x 5
11	9394-014	Hex Nut 5/8-11UNC
12	9404-029	Lock Washer 5/8
13	9928	Locknut 3/8-16UNC
14	23427	Spacer (8-30 Case 1200 ONLY)

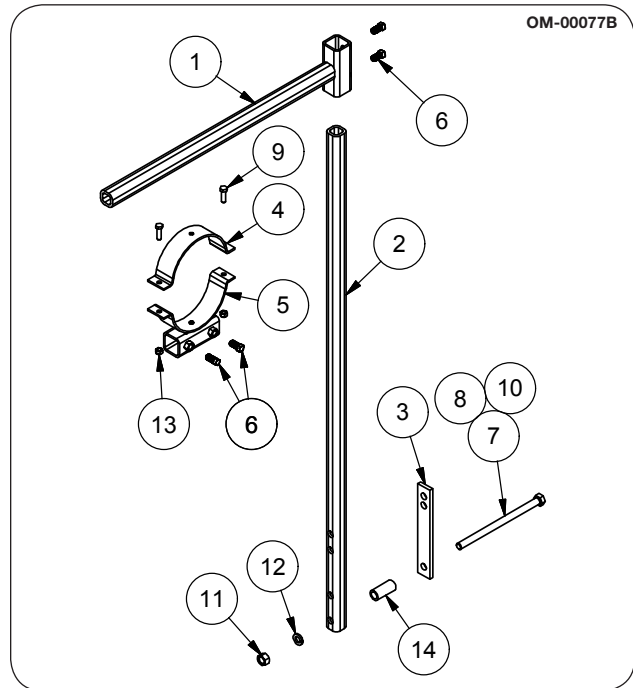

ITEM	PART NO.	DESCRIPTION
*1	22763	Mounting Bundle
2	20355	Tube Weldment
**3	20453	Plate
4	2003035B	Tube Weldment
5	20819	Clamp
6	20827	Strap Weldment
7	91235	Set Screw 1/2-13UNC x 1
8	91435	Capscrew 5/8-11UNC x 9 1/2
9	9390-056	Capscrew 3/8-16UNC x 1 1/4
10	9394-014	Hex Nut 5/8-11UNC
11	9404-029	Lock Washer 5/8
12	9928	Locknut 3/8-16UNC
13	9802	Locknut 3/4-10UNC
***14	2003039B	Tube Weldment

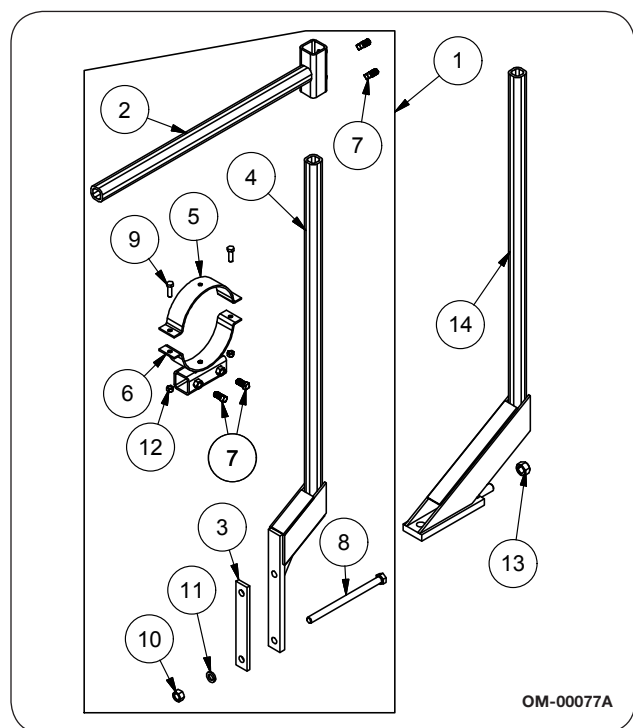

* 22763 - Mounting Bracket Bundle (includes items 2 through 12 for loose sales)

** 22762 - Hardware Bundle (includes items 3 and 7 through 12 for mounting bracket assembly)

*** Used only on John Deere Planters with frame mounted coulters.

CROSS AUGER — Parts

Mounting Brackets — For 6 Row / 8 Row Narrow Planters Kinze 2500/3500 (6/8 Row - 30")

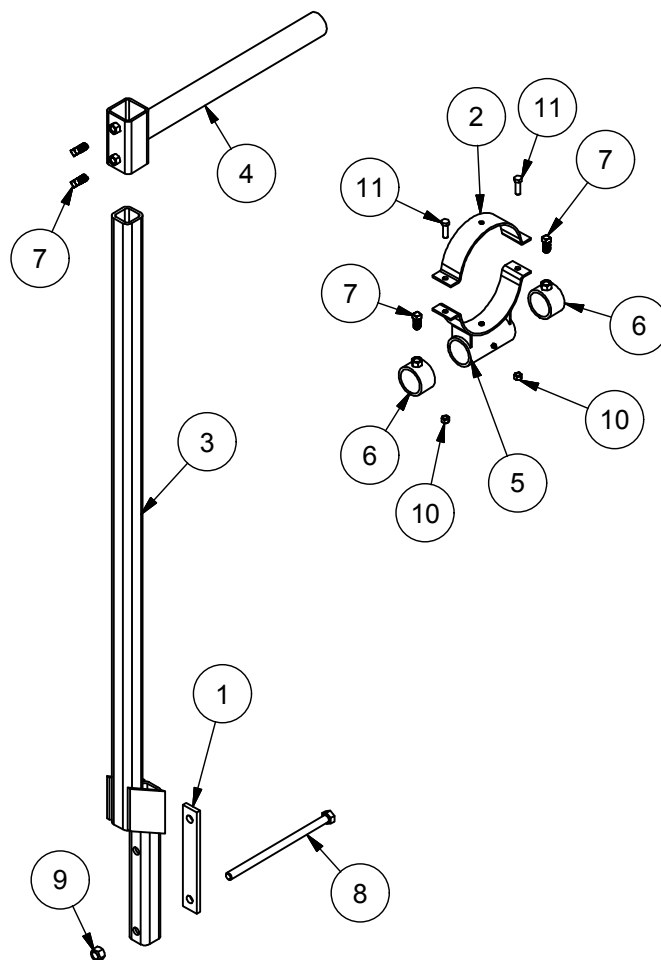

OM-03769

ITEM	PART NO.	DESCRIPTION
1	20453	Mounting Plate
2	20819	Clamp
3	2003038B	Tube Weldment
4	20968	Tube Weldment
5	20974	Strap Weldment
6	20976	Tube Weldment
7	91235	Set Screw 1/2-13UNC x 1
8	9390-445	Capscrew 5/8-11UNC x 11
9	9801	Locknut 5/8-11UNC
10	9928	Locknut 3/8-16UNC
11	9390-056	Capscrew 3/8-16UNC x 1 1/4

Part No. 2003040B Complete Mounting Bracket Bundle (includes item numbers 1 through 11).

CROSS AUGER — Parts

Mounting Brackets — For 12 Row Narrow Planters

John Deere 1770, 7000, 7200 Forward Fold (12 Row - 30")

White 6180/8180 Forward Fold (12 Row - 30")

ITEM	PART NO.	DESCRIPTION
1	20355	Tube Weldment
2	2003017B	Tube
3	20727	Plate
4	20819	Clamp
5	20827	Strap Weldment
6	91235	Set Screw 1/2-13UNC x 1
7	9390-443	Capscrew 5/8-11UNC x 10
8	91435	Capscrew 5/8-11UNC x 9 1/2
9	9390-056	Capscrew 3/8-16UNC x 1 1/4
10	9394-014	Hex Nut 5/8-11UNC
11	9404-029	Lock Washer 5/8
12	9928	Locknut 3/8-16UNC

NOTE: Complete Mounting Bracket Bundle Part Number 2003018B

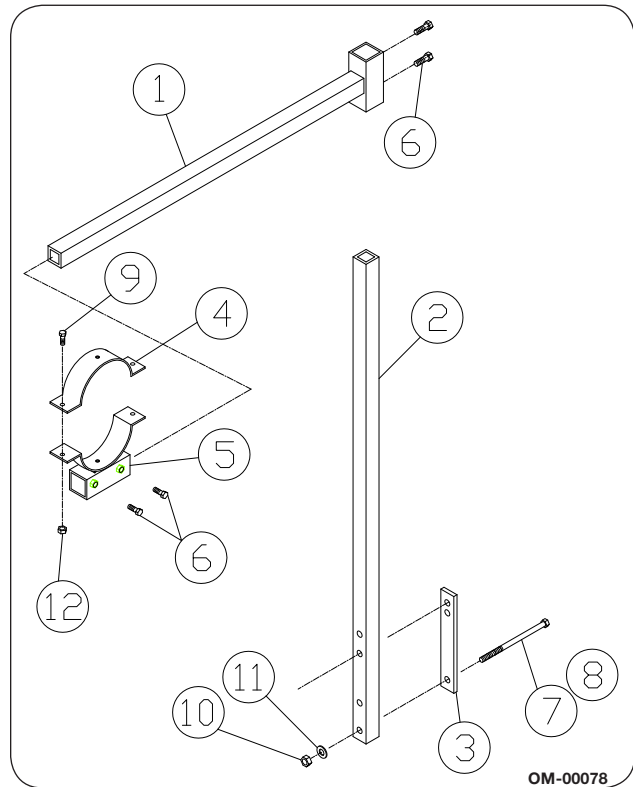

CROSS AUGER — Parts

Mounting Brackets — For 16 Row Narrow Planters John Deere 1770/7200 Flex Fold (16 Row - 30")

ITEM	PART NO.	DESCRIPTION
1	20453	Mounting Plate
2	20819	Clamp
3	2003038B	Tube Weldment
4	20967	Tube Weldment
5	20968	Tube Weldment
6	20970	Tube Weldment
7	20974	Strap Weldment
8	20976	Tube Weldment (Lock Collar)
9	91235	Set Screw 1/2-13UNC x 1
10	9390-445	Capscrew 5/8-11UNC x 11
11	9801	Locknut 5/8-11UNC
12	9928	Locknut 3/8-16UNC
13	9390-056	Capscrew 3/8-16UNC x 1 1/4

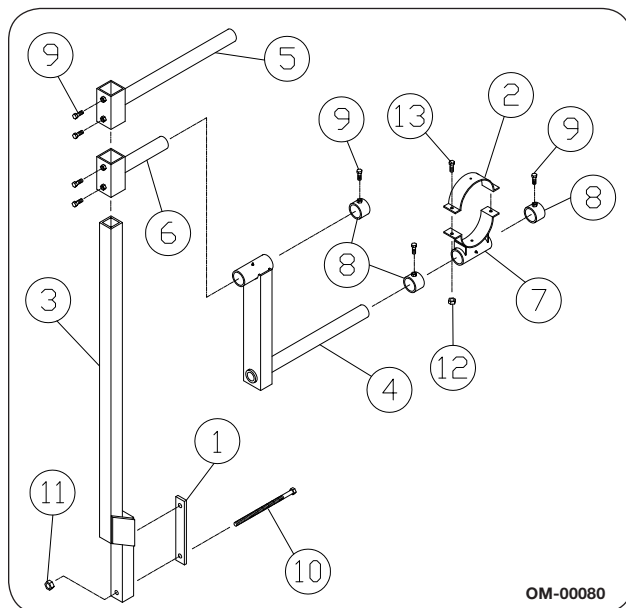

NOTE: Complete Mounting Bracket Bundle Part Number 2003042B

Mounting Brackets — For 16 Row Narrow Planters White 6180/8180 Front Fold (16 Row - 30")

ITEM	PART NO.	DESCRIPTION
1	20355	Tube Weldment
2	2003017B	Tube
3	20727	Plate
4	20819	Clamp
5	20827	Strap Weldment
6	91235	Set Screw 1/2-13UNC x 1
7	9390-443	Capscrew 5/8-11UNC x 10
8	9390-134	Capscrew 5/8-11UNC x 5
9	9390-056	Capscrew 3/8-16UNC x 1 1/4
10	9394-014	Hex Nut 5/8-11UNC
11	9404-029	Lock Washer 5/8"
12	9928	Locknut 3/8-16UNC

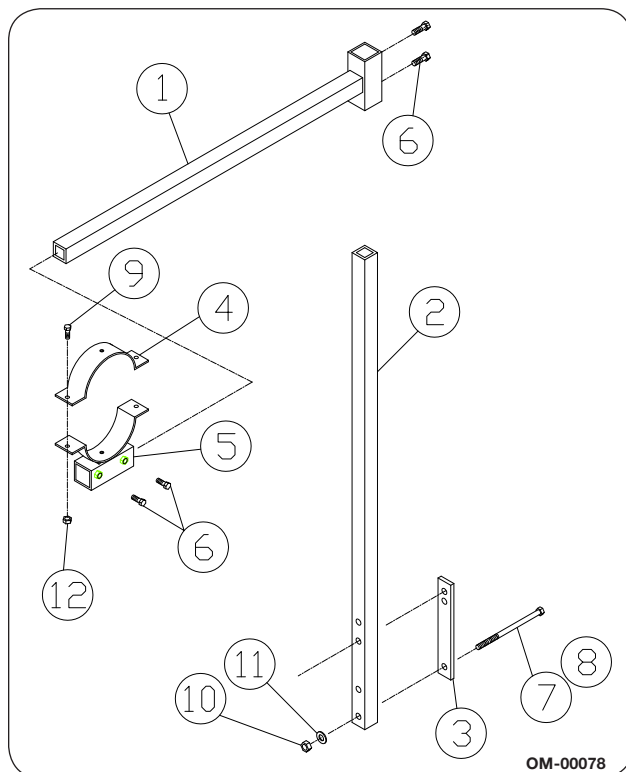

NOTE: Complete Mounting Bracket Bundle Part Number 2003018B

Motor / Valve / Motor Mounting End Cap

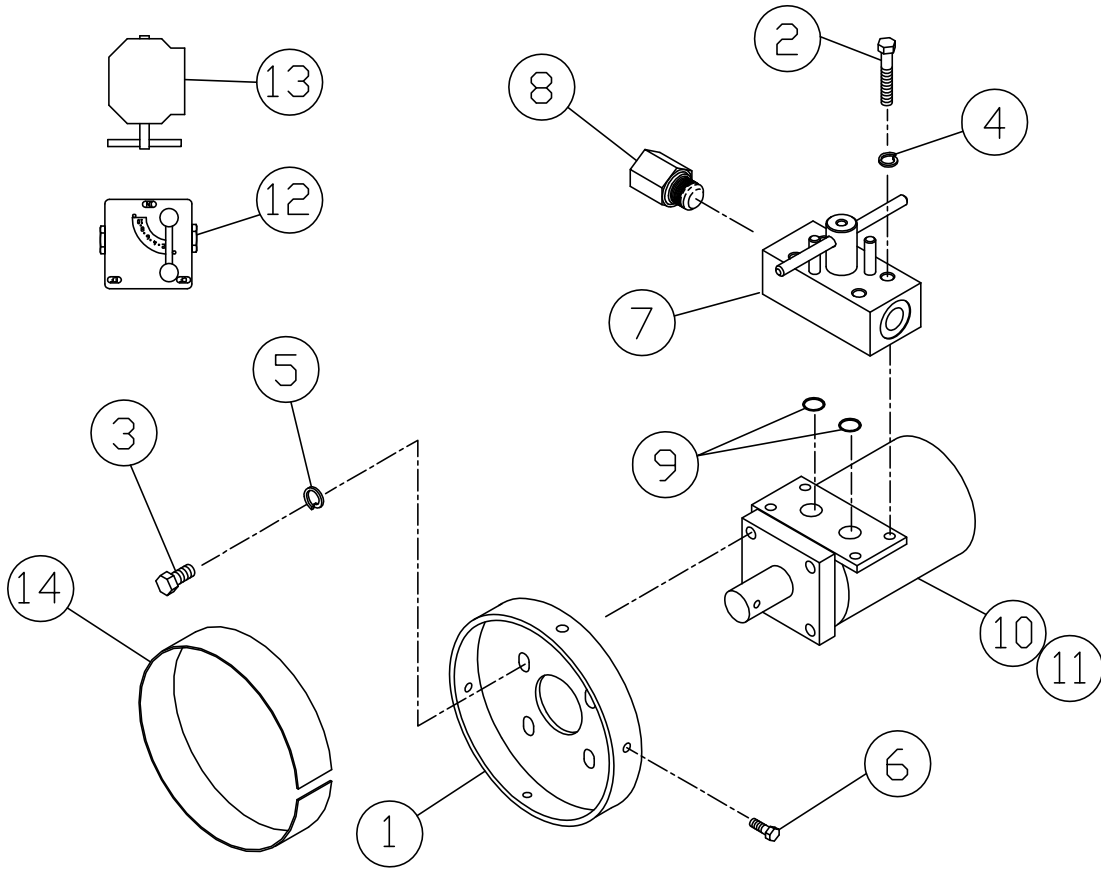

OM-00081

Motor / Valve / Motor Mounting End Cap

ITEM	PART NO.	DESCRIPTION
1	20349	End Cap
2	9390-034	Capscrew 5/16-18UNC x 2
3	9390-053	Capscrew 3/8-16UNC x 3/4
4	9404-019	Lock Washer 5/16"
5	9404-021	Lock Washer 3/8"
6	9512	Self Drilling Screw 1/4-20 x 1
7	22709	Selector Valve
	22752	Handle ONLY
8	94909	Check Valve
9	91306	O-Ring (For Repairs ONLY)
10	91604	Motor
11	91687	Motor Seal Kit (For Repairs ONLY)
12	21125	Optional Speed/Flow Control Valve
13	91280	Optional 3-Way Selector Valve
14	22519	Spacer Ring
	96918	Seal Kit for Selector Valve 22709
	96878	Seal Kit for Speed/Flow Control Valve

NOTE: Complete Motor Assembly Part Number 20817, which includes items 1-5, 7-8, and 10.

CROSS AUGER — Parts

Molded Parts, Hardware, & Decals

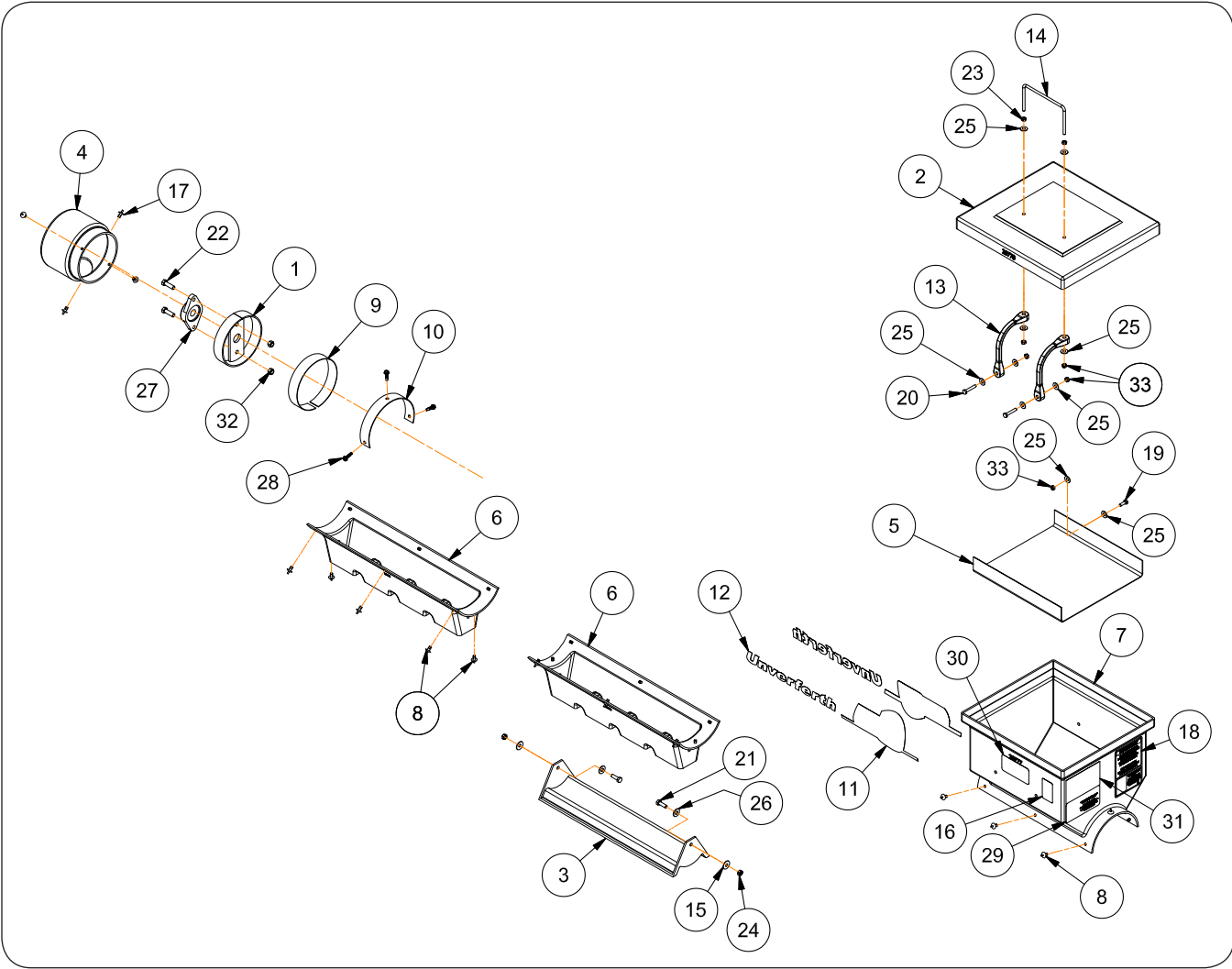

Molded Parts, Hardware, & Decals

ITEM	PART NO.	DESCRIPTION
1	2004156B	Hanger Weldment =BLACK=
2	20778	Hopper Lid/Molded Plastic
3	20780	Close-Off Door (Plastic)
4	20781	End Cap/Molded Plastic
5	20791	Guard
6	20779	Drop/Molded Plastic
7	20777	Hopper/Molded Plastic
8	92204	Drive Rivet 1/4" Dia.
9	22519	Ring/Spacer
10	26762	Band - Reinforcement
11	901607	Decal, UM Oval
12	901725	Decal, Unverferth Logo (Grey)
13	91222	Rubber Strap 9"
14	91290	U-Bolt 1/4"-20UNC
15	91297	Belleville Washer 15/16"
16	91605	Decal, FEMA
17	92204	Drive Rivet
18	93694	Decal "Important" "To Maximize Auger Capacity..."
19	9390-003	Capscrew 1/4"-20UNC x 3/4" (Grade 5)
20	9390-007	Capscrew 1/4"-20UNC x 1 1/2" (Grade 5)
21	9390-030	Capscrew 5/16"-18UNC x 1" (Grade 5)
22	9390-056	Capscrew 3/8"-16UNC x 1 1/4" (Grade 5)
23	9394-002	Hex Nut 1/4"-20UNC
24	9398-010	Elastic Locknut 5/16"-18UNC
25	9405-064	Flat Washer 1/4" USS
26	9405-070	Flat Washer 5/16" USS
27	95004	Flange Bearing w/Setscrew
28	9512	Screw/Self Drill 1/4-14 x 1"
29	95445	Decal, WARNING "High Pressure Fluid"
30	97961	Decal, WARNING "Read and Understand Operator Manual"
31	98766	Decal, WARNING "Rotating Auger"
32	9928	Locknut/Top 3/8"-16UNC
33	9936	Locknut 1/4"-20UNC

CROSS AUGER — Parts

Auger Tube and Flighting — For 6 Row Narrow Planters

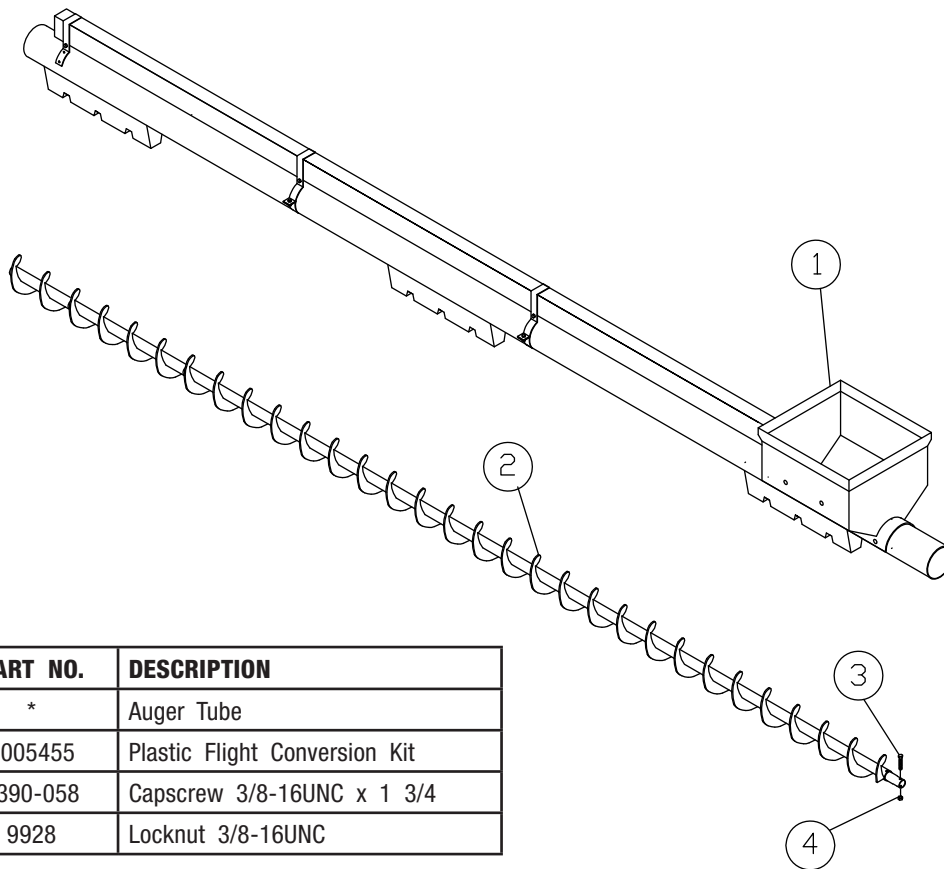

ITEM	PART NO.	DESCRIPTION
1	*	Auger Tube
2	2005455	Plastic Flight Conversion Kit
3	9390-058	Capscrew 3/8-16UNC x 1 3/4
4	9928	Locknut 3/8-16UNC

OM-00087

PLANTER (6-30 SIZES)		*ITEM 1 AUGER TUBE #
MODEL	ROW SPACING	
CASE I.H.		
800, 900, 950, 955, 1200, 1220, 1225	30"	27219
DEUTZ-ALLIS		
385	28, 30"	27221
JOHN DEERE		
1750 & 7200 Drawn Frame Mounted Coulters	30"	27221
1750, 1780, 7000, 7200, 7240	30"	27221
KINZE		
2500/3500 Twin-Line	30"	27221
2000/3000 Single & Double Frame		
NEW IDEA		
900S, 900D, 9200, 9300, 9800, 9900	30"	27221
WHITE		
5100, 6100, 6600	30"	27221
NEW HOLLAND		
480	30"	27219

CROSS AUGER — Parts

Auger Tube and Flighting — For 8 Row Narrow Planters

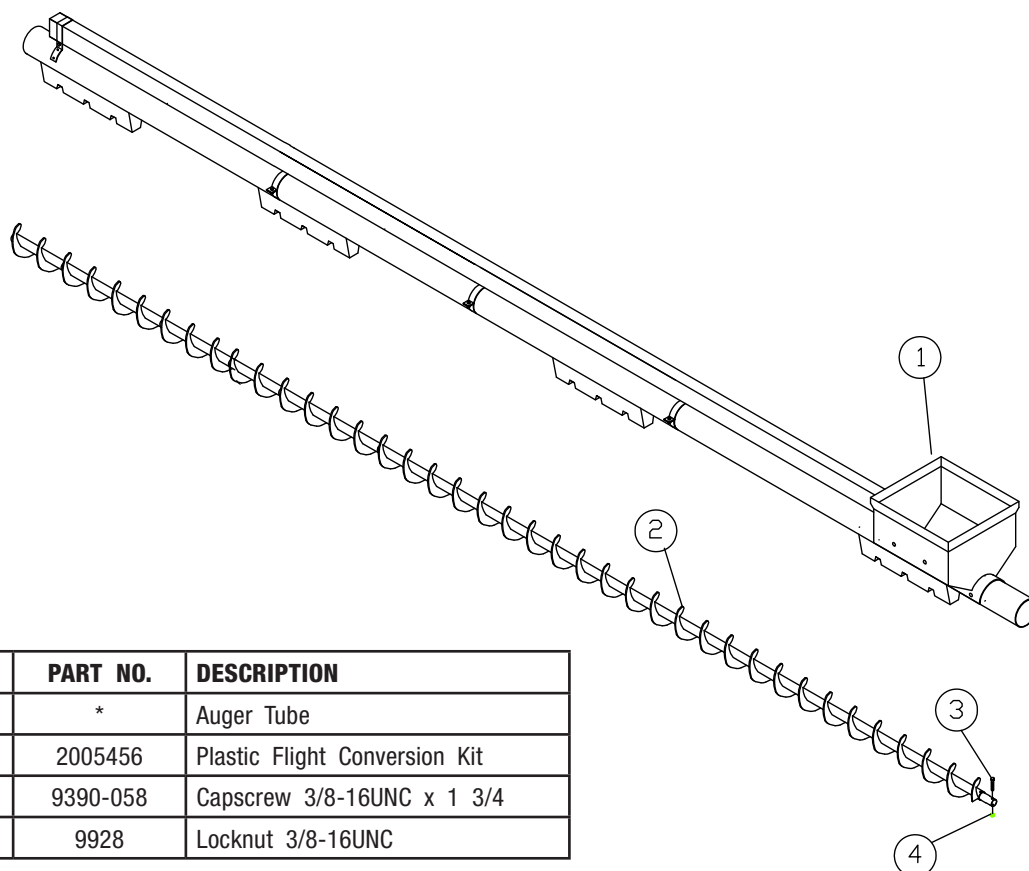

ITEM	PART NO.	DESCRIPTION
1	*	Auger Tube
2	2005456	Plastic Flight Conversion Kit
3	9390-058	Capscrew 3/8-16UNC x 1 3/4
4	9928	Locknut 3/8-16UNC

OM-00092

PLANTER (8-30 SIZES)		*ITEM 1 AUGER TUBE #
MODEL	ROW SPACING	
CASE I.H.		
1200/1220/1225	30"	2005414
DEUTZ-ALLIS		
385	30"	27218
JOHN DEERE		
1780 & 7240 Double Frame	30"	27218
1750, 7000, 7200 Standard & Conservative Frame	30"	2005417
KINZE		
2500/3500 Twin-Line	30"	27218
2000/3000 Single & Double Frame		
NEW IDEA		
900S, 900D, 9200, 9800	30"	27218
WHITE		
5100, 6100, 8100	30"	27218
NEW HOLLAND		
480	30"	2005414

CROSS AUGER — Parts

Auger Tube and Flighting — For 12 Row Narrow Planters

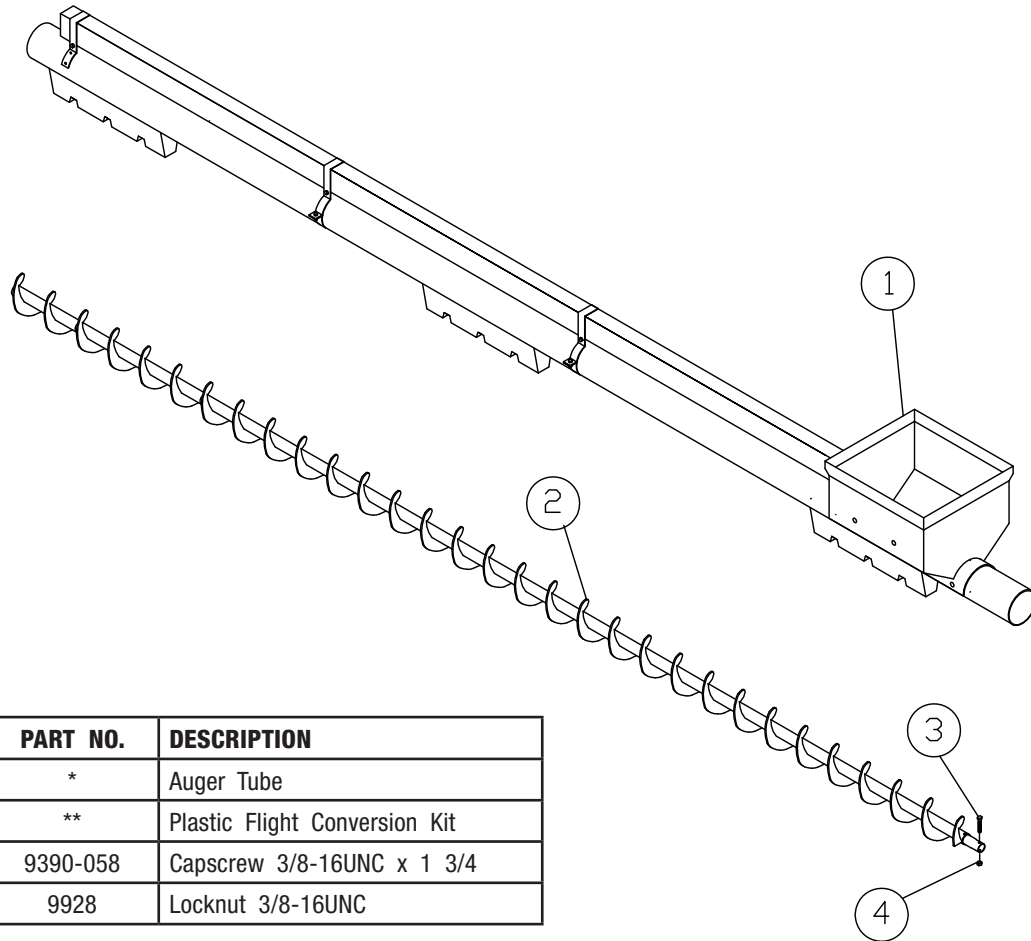

ITEM	PART NO.	DESCRIPTION
1	*	Auger Tube
2	**	Plastic Flight Conversion Kit
3	9390-058	Capscrew 3/8-16UNC x 1 3/4
4	9928	Locknut 3/8-16UNC

OM-00087

PLANTER (12-30 SIZES)		*ITEM 1 AUGER TUBE #	**ITEM 2 PLASTIC FLIGHT CONVERSION KIT
MODEL	ROW SPACING		
JOHN DEERE			
1770	30"	27220	2005457
7000 FRONT-FOLD			
7200 FLEX-FOLD			
WHITE			
6180, 8180	30"	27216	2005455

CROSS AUGER — Parts

Auger Tube and Flighting — For 16 Row Narrow Planters

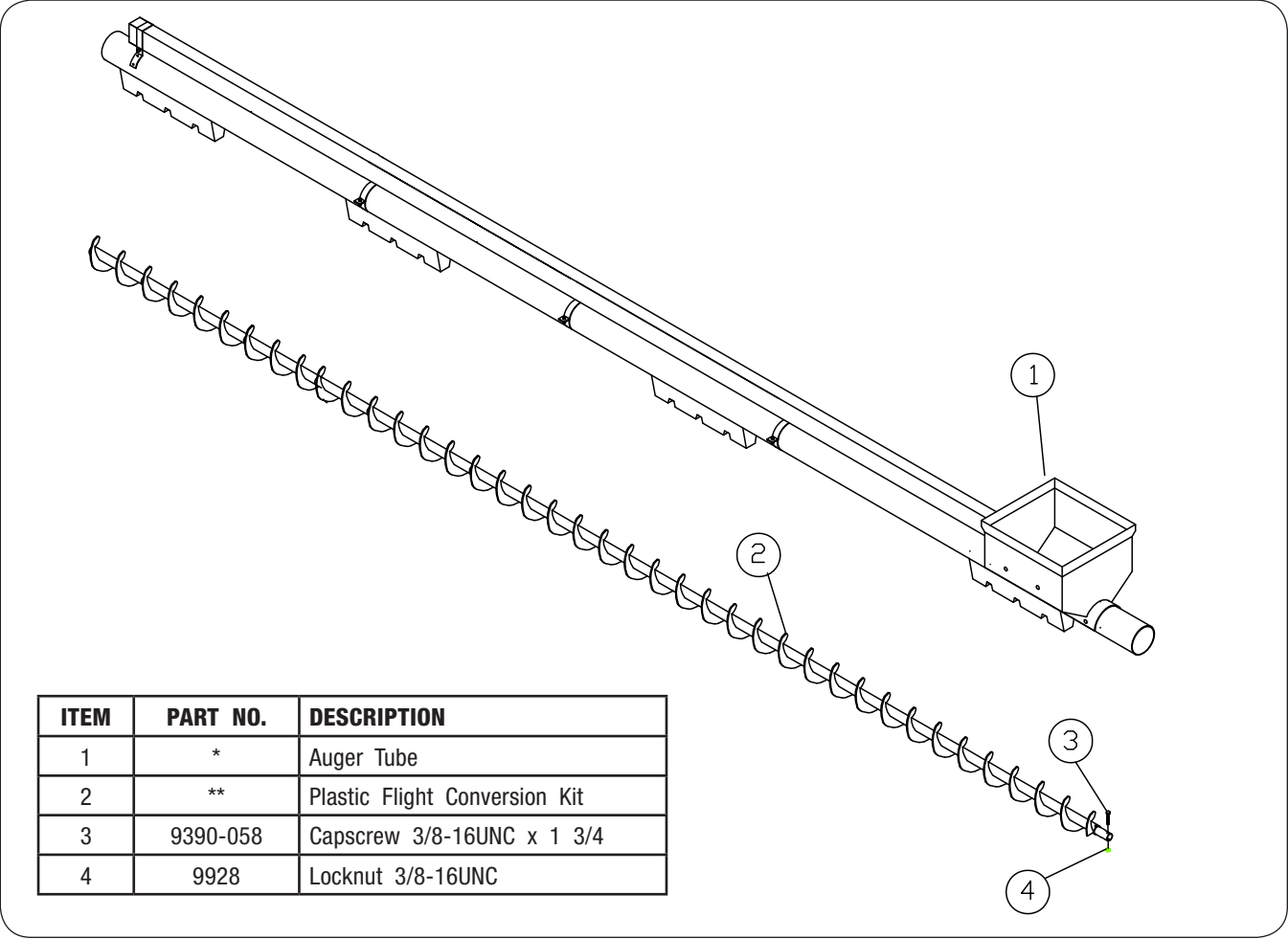

ITEM	PART NO.	DESCRIPTION
1	*	Auger Tube
2	**	Plastic Flight Conversion Kit
3	9390-058	Capscrew 3/8-16UNC x 1 3/4
4	9928	Locknut 3/8-16UNC

PLANTER (16-30 SIZES)		*ITEM 1 AUGER TUBE #	**ITEM 2 PLASTIC FLIGHT CONVERSION KIT
MODEL	ROW SPACING		
JOHN DEERE			
1770	30"	20979	2005458
7200 FLEX-FOLD			
WHITE			
6180 FORWARD-FOLD	30"	27217	2005456

Stiffener Brace/Clamps

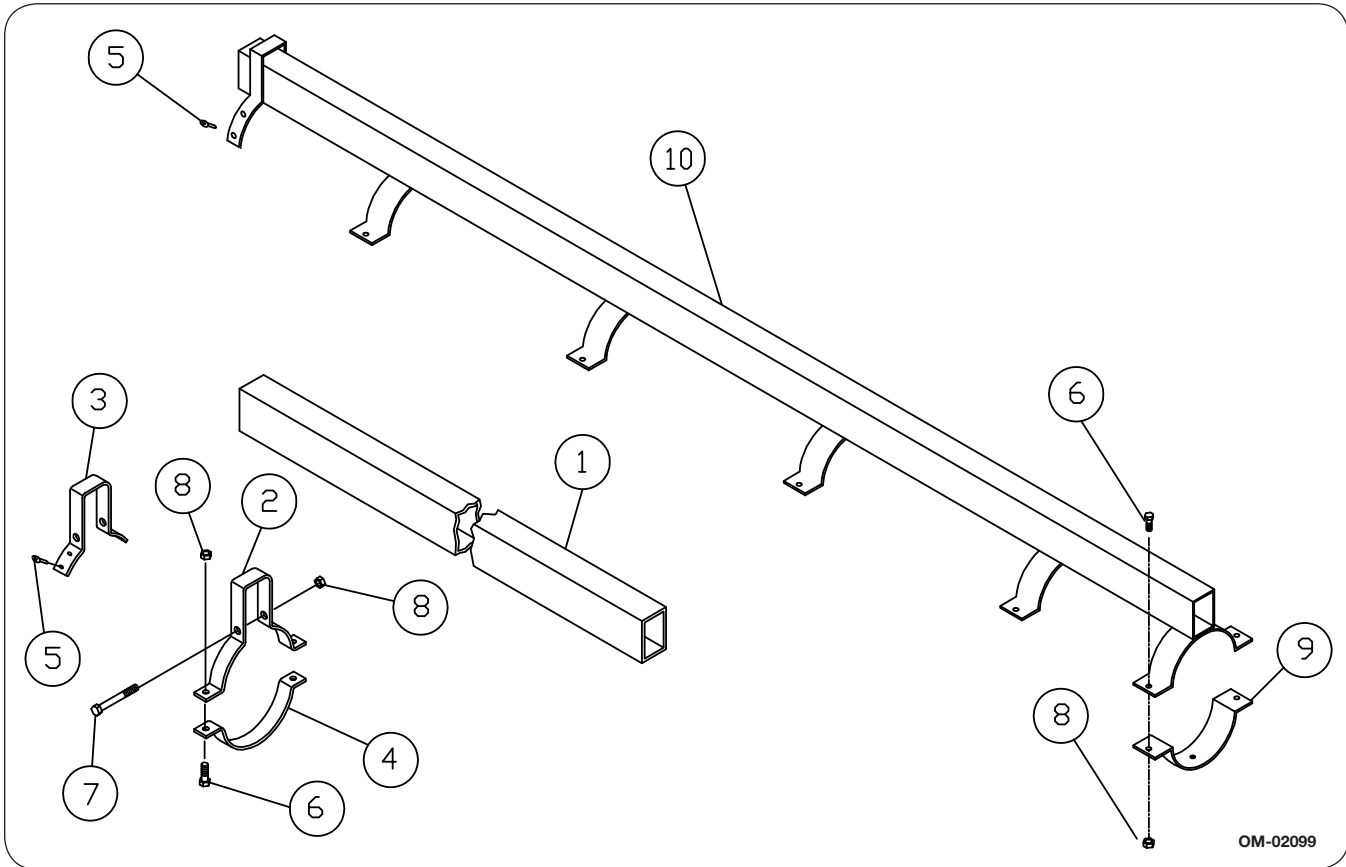

ITEM	PART NO.	DESCRIPTION
1	21027B	Tube - 120" Long
	21031	Tube - 180" Long
2	21037	Strap - Bolted
3	21038B	Strap - Riveted
4	20741	Clamp - 1" Wide
5	92204	Drive Rivet
6	9390-056	Capscrew 3/8-16UNC x 1 1/4
7	9390-063	Capscrew 3/8-16UNC x 3
8	9928	Locknut 3/8-16UNC
9	20819	Clamp
*10	20972	Brace Weldment

* Used only on John Deere 7200 Flex-Fold 16 Row Narrow.

End Bearing and Shaft Components

OM-01367

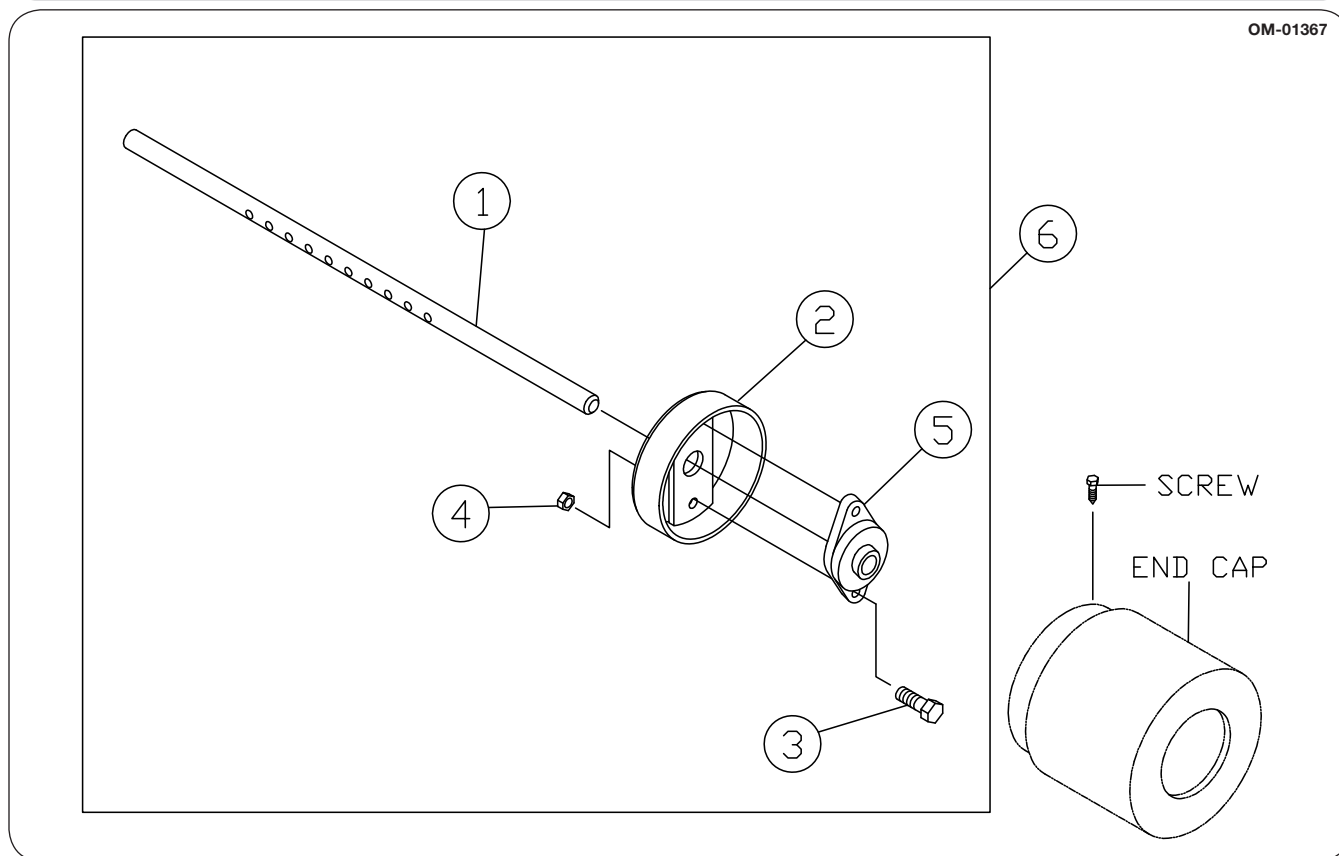

ITEM	PART NO.	DESCRIPTION
1	21559	Shaft 1 3/16" O.D. (For Plastic Flighting)
2	21562	Bearing Hanger
3	9390-056	Capscrew 3/8-16UNC x 1 1/4
4	9928	Locknut 3/8-16UNC
5	95004	Bearing
6	21566	End Bearing Assembly

Control Valve Package #21125 (Optional)

This adjustable flow control valve package will allow the operator to adjust the flow on tractor's with high-capacity hydraulic systems to a max recommended operating flow of 8 - 12 gpm.

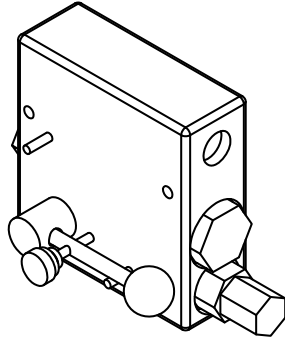

Relief Valve Bundle #23647 (Optional)

This bundle will allow excessive hydraulic pressure to bypass the motor to prevent damage.

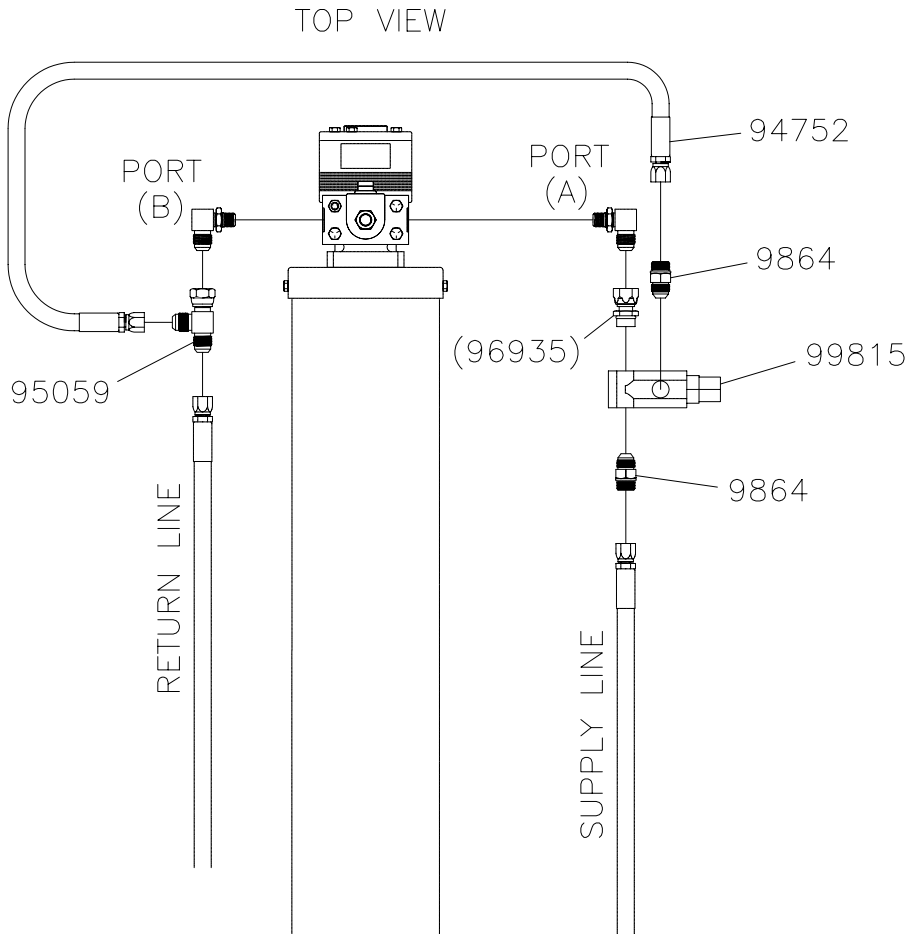

Valve/3-Way Selector #91280 (Optional)

This valve will allow one pump source to supply two separate circuits.





Unverferth[®]
Manufacturing Company, Inc.

www.unverferth.com