



## Grain Handling

### TRUCK AUGER TRA-14 / TRAB-14

Beginning With Serial Number A13000100 & Higher

Part No. 22847

## Foreword



This symbol identifies important safety messages. When you see it, read the message that follows and be alert to the possibility of personal injury.

Remember, safety instructions stated in this manual are for your protection. Read them carefully and follow them closely when working around or using this machine.

Read and study this manual completely before attempting to operate this implement. Take this manual to the field for handy reference when operating, adjusting, or servicing your machine.

When referenced, “Right-Hand” (RH) and “Left-Hand” (LH) side of the machine are determined by standing behind the machine and facing in the direction of travel.



## Product Information

When ordering parts or when requesting further information or assistance, always give the following information:

- Serial number

All products manufactured by Unverferth Mfg. Co., Inc. are warranted to be free from material and workmanship defects for one full year from time of consumer delivery. Your local dealer will gladly assist you with any warranty questions.

Please fill out and retain this portion for your records. The serial number plate is located on the outside of the bracket for the winch mounting (Fig. 1).

Purchase Date \_\_\_\_\_ Model \_\_\_\_\_ Serial No.'s \_\_\_\_\_

Dealer \_\_\_\_\_ City \_\_\_\_\_

Dealer Contact \_\_\_\_\_ Phone \_\_\_\_\_

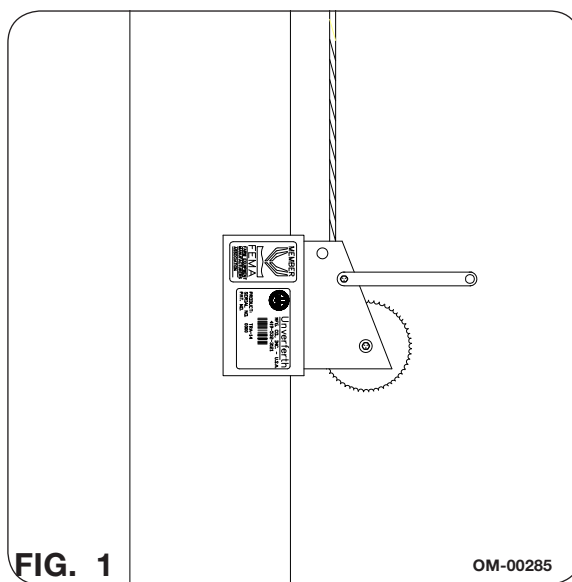

### IMPORTANT

*The information, specifications, and illustrations in the manual are on the basis of information available at the time it was written. Due to continuing improvements in the design and manufacture of Unverferth products, all specifications and information contained herein are subject to change without notice.*

**Table of Contents**

Foreword .....2  
Product Information.....3

**SECTION I**  
**Safety**

General Hazard Information ..... 1-2  
Safety Decals ..... 1-3  
Following Safety Instructions ..... 1-4  
Before Servicing..... 1-4  
Before Operating ..... 1-5  
During Operation ..... 1-5  
Before Transporting ..... 1-5  
During Transport..... 1-6  
Pressurized Oil ..... 1-6  
Preparing for Emergencies..... 1-7  
Wearing Protective Equipment ..... 1-7

**SECTION II**  
**Set Up**

General Set Up Information ..... 2-2  
Step 1: Preparing Truck ..... 2-3  
Step 2: Auger Set Up..... 2-4 through 2-9  
    Cable & Chain Assembly..... 2-5  
    Winch Assembly ..... 2-6  
    Connecting Auger Tubes..... 2-7  
    Spout Assembly ..... 2-8  
    Wire Assembly ..... 2-9  
Step 3: Attach Auger To Truck..... 2-10 through 2-23  
    Connecting Hydraulics To Auger With Steel Flighting (Left-Hand)..... 2-10  
    Hydraulic Diagram For Left-Hand Wound Flighting  
        Diagram A - One-Way System (Open-Center System)..... 2-12  
        Diagram B - Two-Way System (Open-Center System) ..... 2-13  
        Diagram C - One-Way System (Closed-Center System)..... 2-14  
        Diagram D - Two-Way System (Closed-Center System)..... 2-15  
    Connecting Hydraulics To Auger With  
        Steel & Bristle Flighting (Right-Hand) ..... 2-16  
    Hydraulic Diagram For Right-Hand Wound Flighting  
        Diagram A - One-Way System (Open-Center System)..... 2-18  
        Diagram B - Two-Way System (Open-Center System) ..... 2-19  
        Diagram C - One-Way System (Closed-Center System)..... 2-20  
        Diagram D - Two-Way System (Closed-Center System)..... 2-21  
    Flow Control Valve ..... 2-22  
    Electrical Components ..... 2-23

**Table of Contents**

## **SECTION III**

# **Operation**

General Information.....	3-2
Preparing Truck.....	3-2
Attaching Auger To Truck.....	3-3
Removing The Auger From The Truck.....	3-5
Before Transporting.....	3-5
Transporting.....	3-6
Operating Auger.....	3-7
Performance.....	3-8

## **SECTION IV**

# **Maintenance**

Lubrication	
Upper Tube Bearing.....	4-2
Lower Tube Bearing.....	4-2
Swivel Clamps.....	4-2
Miscellaneous Lube Points.....	4-2
Storage/Maintenance.....	4-3
Complete Torque Chart.....	4-4
Hydraulic Fittings - Torque and Installation.....	4-4
Troubleshooting	
Auger Will Not Turn Over Or Develop Proper Speed/Torque.....	4-5
Auger Creeps When Spout Switch Is Shut-Off.....	4-5
Auger Is Turning In Wrong Direction.....	4-6
Oil Heat Excessively.....	4-6
Pump/Motors/Seals Blow - Shaft/Housing Breaks - Hose Burst.....	4-6
Dead Battery.....	4-6
If Switch Does Not Operate Auger Motor.....	4-7
Electrical Specifications.....	4-7

## **SECTION V**

# **Parts**

Lower Auger Components.....	5-2
Upper Auger Components.....	5-4
Hopper and Mounting Components.....	5-6
Transport Latch.....	5-8
Winch and Safety Cable.....	5-9
Wiring Harness & Valves.....	5-10

**Notes**

# SECTION I

# Safety

General Hazard Information .....	1-2
Safety Decals .....	1-3
Following Safety Instructions .....	1-4
Before Servicing.....	1-4
Before Operating.....	1-5
During Operation.....	1-5
Before Transporting .....	1-5
During Transport.....	1-6
Pressurized Oil .....	1-6
Preparing for Emergencies.....	1-7
Wearing Protective Equipment .....	1-7

## General Hazard Information

No accident-prevention program can be successful without the wholehearted cooperation of the person who is directly responsible for the operation of the equipment.

A large number of accidents can be prevented only by the operator anticipating the result before the accident is caused and doing something about it. No power-driven equipment, whether it be transportation or processing, whether it be on the highway, in the harvest field, or in the industrial plant, can be safer than the person who is at the controls. If accidents are to be prevented--and they can be prevented--it will be done by the operators who accept the full measure of their responsibility.

It is true that the designer, the manufacturer, and the safety engineer can help; and they will help, but their combined efforts can be wiped out by a single careless act of the operator.

It is said that, "the best kind of a safety device is a careful operator." We, at Unverferth Mfg. Co., Inc. ask that you be that kind of operator.



**REMEMBER:**  
**THINK SAFETY**  
A CAREFUL OPERATOR IS THE  
BEST INSURANCE AGAINST AN  
ACCIDENT!

### SIGNAL WORDS



INDICATES AN EXTREMELY HAZARDOUS SITUATION OR ACTION THAT WILL RESULT IN SERIOUS INJURY OR DEATH.



INDICATES A HAZARDOUS SITUATION OR ACTION THAT COULD RESULT IN SERIOUS INJURY OR DEATH.



INDICATES AN UNSAFE SITUATION OR ACTION THAT MAY RESULT IN PERSONAL INJURY.



*Is used for instruction on operating, adjusting, or servicing a machine.*



**Safety Decals**



**PART NO. 97048**



**PART NO. 93552**



**PART NO. 93551**



**PART NO. 93558**



**PART NO. 97961**

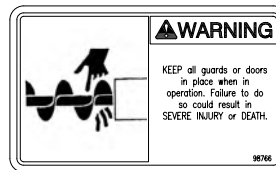

**PART NO. 98766**

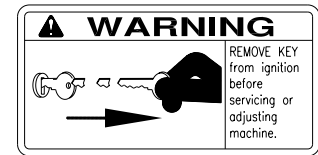

**PART NO. 97200**

## Following Safety Instructions

- Read and understand this operator's manual before operating.



- All machinery should be operated only by trained and authorized personnel.

- To prevent machine damage, use only attachments and service parts approved by the manufacturer.

- Always shut tractor engine off and remove key before servicing.



- Avoid personal attire such as loose fitting clothing, shoestrings, drawstrings, pants cuffs, long hair, etc., that may become entangled in moving parts.

- Do not allow anyone to ride on the implement. Make sure everyone is clear before operating machine or towing vehicle.



## Before Servicing

- Avoid working under an implement; however, if it becomes absolutely unavoidable, make sure the implement is safely blocked.



- Ensure that all applicable safety decals are installed and legible.

- When working around the implement, be careful not to be cut by sharp edges.

## Before Operating

- Do not stand between towing vehicle and implement during hitching.

---
- Always make certain everyone and everything is clear of the machine before beginning operation.

---
- Verify that all safety shields are in place and properly secured.

---
- Ensure that all applicable safety decals are installed and legible.

---
- When working around the implement, be careful not to be cut by sharp edges.

## During Operation

- Regulate speed to field conditions. Maintain complete control at all times.

---
- Never service or lubricate equipment when in operation.

---
- Keep away from overhead power lines. Electrical shock can cause serious injury or death.

---
- Use extreme care when operating close to ditches, fences, or on hillsides.

---
- Do not leave towing vehicle unattended with engine running.

---
- Seed being transported may contain seed treatment. Read and follow all requirements for personal protective equipment and first aid as outlined on seed tags.

## Before Transporting

- Secure transport chains to towing vehicle before transporting. DO NOT transport without chains.

---
- Install transport locks before transporting.

---
- Check for proper function of all available transport lights. Make sure that all reflectors are clean and in place on machine.

### During Transport

- Comply with state and local laws governing highway safety when moving machinery.
- Use transport lights as required by local laws to adequately warn operators of other vehicles.
- Use good judgment when transporting equipment on highways. Regulate speed to road conditions and maintain complete control.
- Maximum speed of implement should never exceed 20 mph. Do not exceed 10 mph during off-highway travel.

### Pressurized Oil

- Relieve the hydraulic system of all pressure before adjusting or servicing. See hydraulic power unit manual for procedure to relieve pressure.
- High-pressure fluids can penetrate the skin and cause serious injury or death. Use cardboard or wood to detect leaks in the hydraulic system. Seek medical treatment immediately if injured by high-pressure fluids.
- Hydraulic system must be purged of air before operating to prevent serious injury or death.
- Do not bend or strike high-pressure lines. Do not install bent or damaged tubes or hoses.
- Repair all oil leaks. Leaks can cause fires, personal injury, and environmental damage.
- Route hoses and lines carefully to prevent premature failure due to kinking and rubbing against other parts. Make sure that all clamps, guards and shields are installed correctly.
- Check hydraulic hoses and tubes carefully. Replace components as necessary if any of the following conditions are found:
  - End fittings damaged, displaced, or leaking.
  - Outer covering chafed/cut or wire reinforcing exposed.
  - Outer covering ballooning locally.
  - Evidence of kinking or crushing of the flexible part of a hose.

### Preparing for Emergencies

- Keep a first aid kit and properly rated fire extinguisher nearby.



- Keep emergency numbers for fire, rescue, and poison control personnel near the phone.



### Wearing Protective Equipment

- Wear clothing and personal protective equipment appropriate for the job.

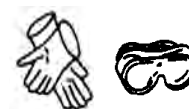

- Wear steel-toed shoes when operating.



- Wear hearing protection when exposed to loud noises.



- Do not wear additional hearing impairing devices such as radio headphones, etc



**Notes**

# **SECTION II**

# **Set Up**

- General Set Up Information ..... 2-2
- Step 1: Preparing Truck ..... 2-3
- Step 2: Auger Set Up..... 2-4 through 2-9
  - Cable & Chain Assembly..... 2-5
  - Winch Assembly ..... 2-6
  - Connecting Auger Tubes..... 2-7
  - Spout Assembly..... 2-8
  - Wire Assembly..... 2-9
- Step 3: Attach Auger To Truck..... 2-10 through 2-23
  - Connecting Hydraulics To Auger With Steel Flighting (Left-Hand)..... 2-10
    - Hydraulic Diagram For Left-Hand Wound Flighting
      - Diagram A - One-Way System (Open-Center System)..... 2-12
      - Diagram B - Two-Way System (Open-Center System) ..... 2-13
      - Diagram C - One-Way System (Closed-Center System)..... 2-14
      - Diagram D - Two-Way System (Closed-Center System)..... 2-15
  - Connecting Hydraulics To Auger With Steel & Bristle Flighting (Right-Hand) ..... 2-16
    - Hydraulic Diagram For Right-Hand Wound Flighting
      - Diagram A - One-Way System (Open-Center System)..... 2-18
      - Diagram B - Two-Way System (Open-Center System) ..... 2-19
      - Diagram C - One-Way System (Closed-Center System)..... 2-20
      - Diagram D - Two-Way System (Closed-Center System)..... 2-21
  - Flow Control Valve ..... 2-22
  - Electrical Components ..... 2-23

## General Set Up Information

This section contains all of the instructions required for the complete assembly of the entire truck auger to the truck.

For your safety, and the safety of others, use proper tools and equipment and always use safe working procedures. Refer to these instructions before starting any work on your machine.

### STEP 1:

Assemble the mounting brackets, transport latch, hydraulics and electrical components of truck (page 2-3).

### STEP 2:

Assemble auger (page 2-4).

### STEP 3:

Assemble auger to truck (page 2-10).

## **WARNING**

- **HIGH-PRESSURE FLUIDS CAN PENETRATE THE SKIN AND CAUSE SERIOUS INJURY OR DEATH. USE CARDBOARD OR WOOD TO DETECT LEAKS IN THE HYDRAULIC SYSTEM. SEEK MEDICAL TREATMENT IMMEDIATELY IF INJURED BY HIGH-PRESSURE FLUIDS.**

---

- **EYE PROTECTION AND OTHER APPROPRIATE PERSONAL PROTECTIVE EQUIPMENT MUST BE WORN WHILE SERVICING IMPLEMENT.**

---

- **KEEP HANDS CLEAR OF PINCH POINT AREAS.**

---

- 1. Park on firm, level surface lower implement to ground, block from moving, set parking brake, shut-off engine, remove ignition key.
- 2. Relieve all hydraulic pressure on planter before installing. See truck operators manual for procedures.
- 3. Use 500 lb. minimum hoist or lifting device for auger.
- 4. Remember to tighten loosened hardware and re-torque to manufacturers specifications.

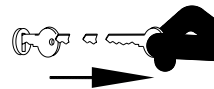



## Step 1: Preparing Truck

### IMPORTANT

- For ease of assembly, install hardware loosely until assembly of each step is complete, then tighten all hardware.
- The procedures for assembling auger tubes were intended for two or more people, for ease and safety.

1. Install brackets to the back of the truck frame by positioning brackets into place and drilling three 1/2" dia. holes per bracket. Secure by inserting three 1/2" flange bolts and flange nuts per bracket. Refer to FIG. 2-1 for proper position.

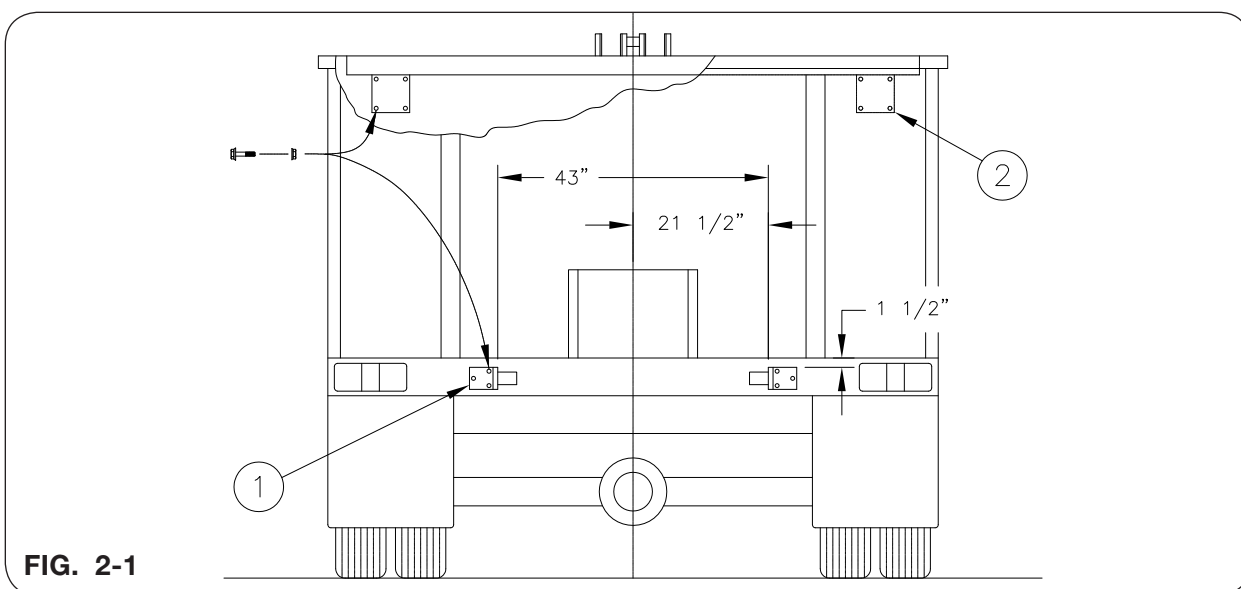

FIG. 2-1

2. Install transport latch weldment to the top inside of the truck box. Drill four 1/2" dia. holes per side and secure with eight 1/2" flange bolts and flange nuts (FIG. 2-1).
3. Tighten all hardware.
4. Install hopper seal to the back of the truck centered around gate. Secure with five self-drilling screws (FIG. 2-2).

**NOTE:** When mounting, seal shims (21112) may be needed so that seal mounts flush with truck gate.

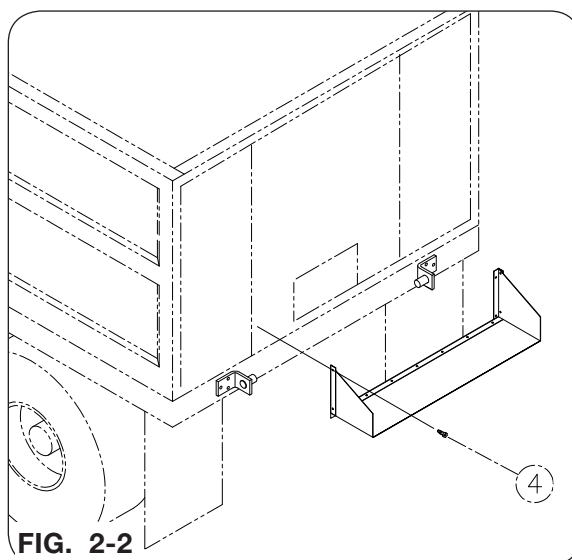

FIG. 2-2

## Step 2: Auger Set Up

### IMPORTANT

- For ease of assembly, install hardware loosely until assembly of each step is complete, then tighten all hardware.
- The procedures for assembling auger tubes were intended for two or more people, for ease and safety.

5. Assemble hopper to the lower tube with eight 3/8-16 x 1" lg. flange screws and flange nuts and tighten (FIG. 2-3).

6. Assemble the gate onto the gate rod and position onto the tube. Secure the rod with two hex nuts 1/2-13 and one lock washer (FIG. 2-3).

**NOTE:** When assembling gate, be sure the gate slides freely, adjust if necessary.

7. Assemble knob to the gate (FIG. 2-3).

8. Attach the winch to the lower tube with two 3/8-16 x 1" lg. flange screws and flange nuts (FIG. 2-3).

9. Place guard into position in the hopper and secure with four 3/8-16 x 1" lg. flange bolts and flange nuts (FIG. 2-4).

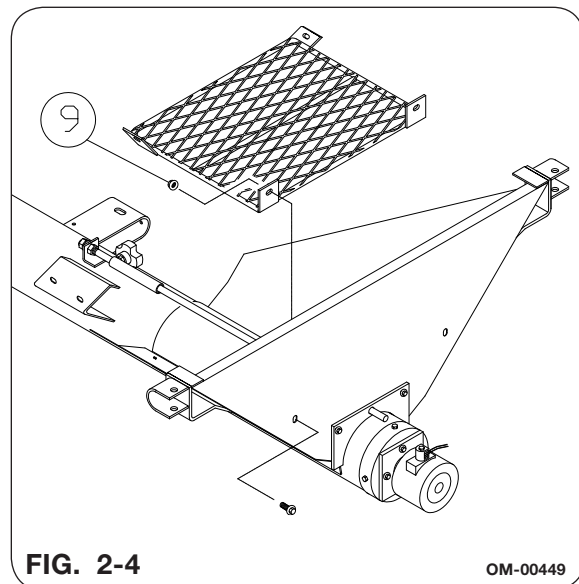
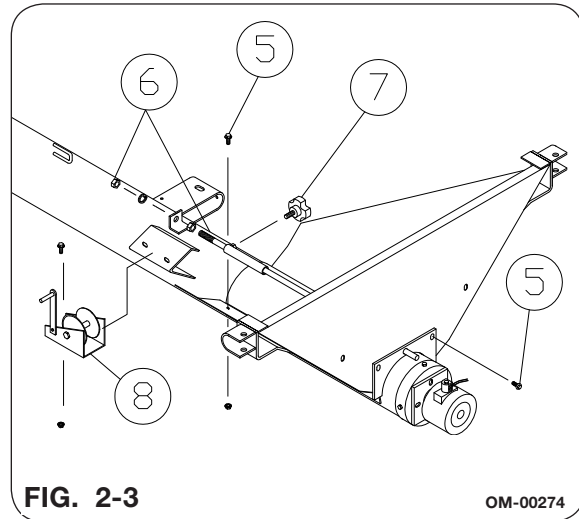

## Step 2: Auger Set Up (Continued)

### Cable & Chain Assembly

10. Assemble six link chain to pulley with quick-link as shown in FIG. 2-5.
11. Install this assembly along with the safety cable to the lower tube as shown. When installing the chain assembly, be sure it is located on the winch side of the tube to prevent twisting with the safety cable. Secure with 3/8-16 x 1 3/4" lg. capscrew and locknut (FIG. 2-5).
12. Assemble the winch cable through the pulley and attach the winch cable to the winch (FIG. 2-5 and refer to "Winch Assembly").

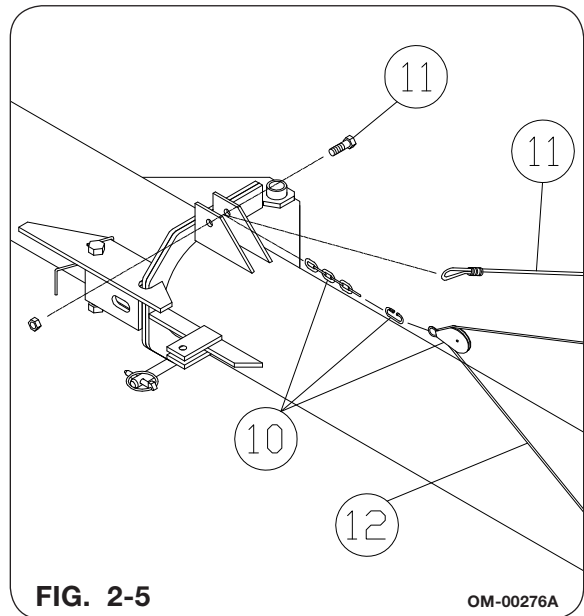

**Step 2: Auger Set Up (Continued)**

**Winch Assembly**

**⚠ WARNING**

- **FALLING EQUIPMENT CAN CAUSE SERIOUS INJURY OR DEATH. BEFORE OPERATING WINCH, BE SURE THAT WINCH IS SECURELY INSTALLED TO THE LIFT FRAME CENTER, AND THE CABLE IS TIED TO THE WINCH AND LEFT HAND LEG WELDMENT. BE SURE TO FOLLOW THESE INSTRUCTIONS, AND THE OPERATING PROCEDURES PROVIDED WITH THE WINCH.**

**IMPORTANT**

- *Refer to proper assembly instructions for your truck auger before installing winch.*

13. Check that all cables and winch are securely installed and not damaged in any way.

14. Tie cable to winch by the following instructions (FIG. 2-7).

**NOTE:** Start cable between spool plate.

15. Thread cable from inside winch, out through hole "A".

16. Continue through hole "B" and hole "C" as shown in FIG. 2-7.

17. Finally, thread back under cable between hole "A" and "B".

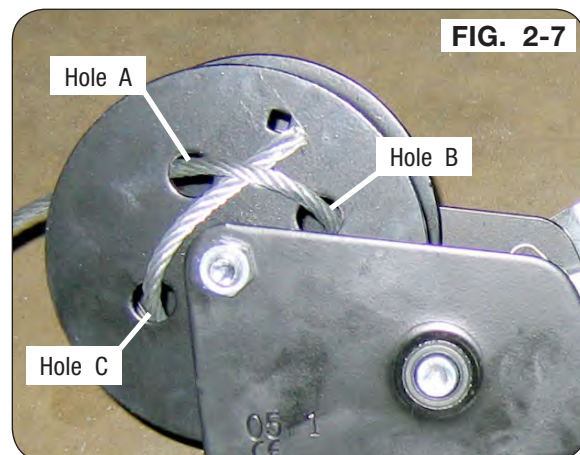

18. When operating the winch, take note of the following guidelines:

- never walk under auger while it is suspended
- never leave auger unattended while it is suspended
- test winch each time by moving auger a few inches out of transport bracket before complete lowering
- never winch auger up or down while it is loaded
- be sure that cable is not kinked or misaligned on winch drum
- always take safety precautions

## Step 2: Auger Set Up (Continued)

### Connecting Auger Tubes



- **ELECTROCUTION WILL CAUSE SERIOUS INJURY OR DEATH. THE AUGER IS NOT INSULATED. KEEP AWAY FROM ALL ELECTRICAL LINES AND DEVICES. ELECTROCUTION CAN OCCUR WITHOUT DIRECT CONTACT.**



- **KEEP HANDS CLEAR OF PINCH POINT AREAS.**

19. Attach the auger halves together with hinge bolt (20194), two 3/4" flat washers (9405-105), and elastic stop nut (9397-016) (FIG. 2-9).

20. Clamp the tube halve together as shown in FIG. 2-9.

**NOTE:** If tube halves do not firmly clamp together, adjust the hook on clamp to allow the handle to lock when activated.

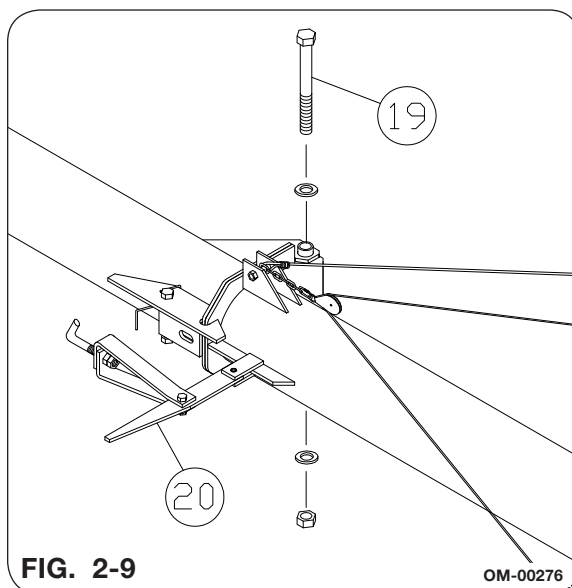

**Step 2: Auger Set Up (Continued)**

**Spout Assembly**

21. Install the telescopic spout to the auger by loosening the clamp and sliding the flexible tubing over the auger spouting. Position approximately 2-3" over the auger spout and retighten the clamp (FIG. 2-10).

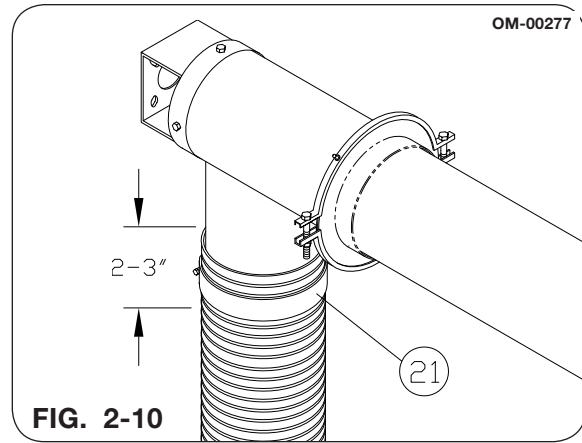
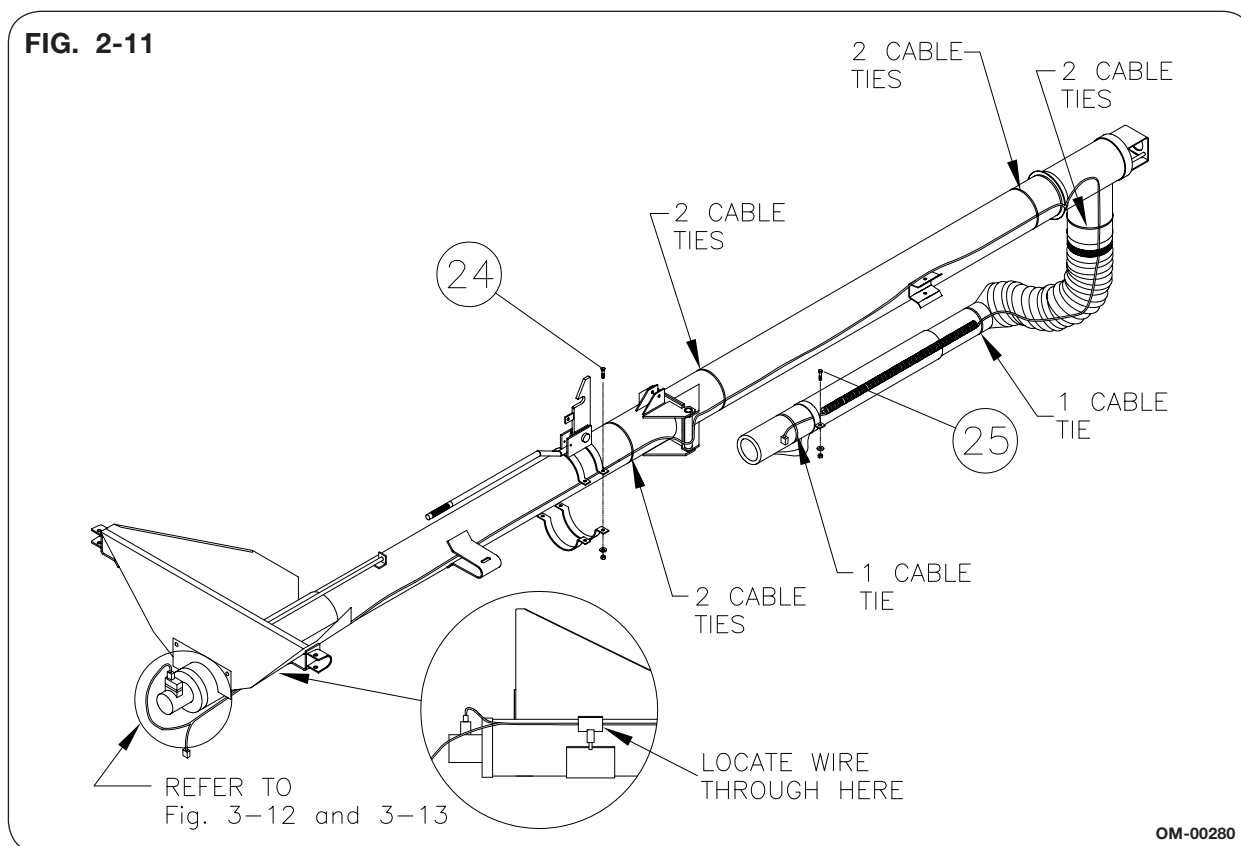

**FIG. 2-10**

## Step 2: Auger Set Up (Continued)

### Wire Assembly

22. Mount the wire assembly (21108) to the auger. Refer to FIG. 2-11 for proper positioning. Secure wire assembly with cable ties (94038) supplied. Position on/off switch approximately 18" from the end of the telescoping spout.
23. Connect the wiring harness to the motor (FIG. 2-12 and FIG. 2-13) and crimp the wires to secure.
24. Attach the transport latch assembly to the lower tube with two straps (2745-B), 3/8-16 x 1 1/2" lg. capscrews (9390-057), lock washer (9404-021), and hex nuts (9394-006). Be sure to run wire assembly between the clamps as shown (FIG. 2-11).



**NOTE:** When tightening the clamp, be sure the wire is not pinched between the auger housing and clamp.

**NOTE:** The clamp will have to be repositioned after the auger is attached to the truck. Be sure the clamp securely locks onto the transport frame. Refer to OPERATIONS section.

25. Secure the spout clamp (21081) onto the telescoping spout end with a 1/4-20 x 1" lg. capscrew (9390-005) lock washer (9404-017), and hex nut (9394-002). Be sure to run the wiring harness through the gap where the clamp is tightened (FIG. 2-11).

**NOTE:** Be sure not to pinch the wiring between the auger and the clamp when tightening.

**NOTE:** For proper positioning of the spout clamp, refer to the OPERATIONS section.

**Step 3: Attach Auger To Truck**

1. Attach the auger to the mounting brackets on the back of the truck bed. Refer to the OPERATIONS section for assembly procedures.

**NOTE:** Refer to "Connecting Hydraulics To Auger With Bristle Flighting".

**Connecting Hydraulics To Auger  
With Steel Flighting (Left-Hand)**

(For Left-Hand Pitch Flighting for Steel Flighting Units Prior to Serial #A40110099)

**NOTE:** For best performance of auger, be sure valve is positioned as shown in FIG. 2-12 for bristle flighting.

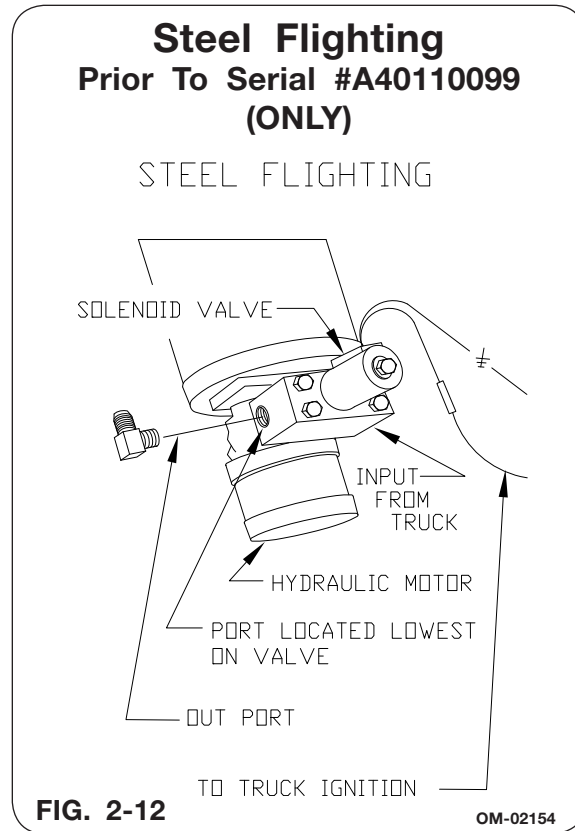

**IMPORTANT**

- To obtain the correct rotation on the auger flight, connect the hydraulic input hose from the truck to the port marked "IN" on the solenoid and the hydraulic return hose to the port on the opposite side of the solenoid.



## Step 3: Attach Auger To Truck (continued)

### **WARNING**

- **HIGH-PRESSURE FLUIDS CAN PENETRATE THE SKIN AND CAUSE SERIOUS INJURY OR DEATH. USE CARDBOARD OR WOOD TO DETECT LEAKS IN THE HYDRAULIC SYSTEM. SEEK MEDICAL TREATMENT IMMEDIATELY IF INJURED BY HIGH-PRESSURE FLUIDS.**
- **RELIEVE THE HYDRAULIC SYSTEM OF ALL PRESSURE BEFORE ADJUSTING OR SERVICING. SEE THE HYDRAULIC POWER UNIT OPERATOR'S MANUAL FOR PROPER PROCEDURES.**

**NOTE:** When installing hydraulics be sure the bed is lowered to relieve all the pressure.

### **IMPORTANT**

- *After hydraulic installation is complete, the system must be purged to prevent damage or rapid movement. Refer to power unit manual for proper purging procedures.*
2. Install hydraulic components (furnished by customer) to truck's hydraulic system. Refer to the following diagrams on pages 2-12 through 2-15 for proper installation.

#### **OPEN-CENTER**

DIAGRAM A: ONE-WAY SYSTEM  
DIAGRAM B: TWO-WAY SYSTEM

#### **CLOSED-CENTER**

DIAGRAM C: ONE-WAY SYSTEM  
DIAGRAM D: TWO-WAY SYSTEM

**NOTE:** Diagrams are shown with the optional selector valve (Unverferth #91280) installed into the system. This valve (or similar) must be used on a single control system (with one-way or two-way hydraulics) to control system function. The selector valve (91280) may be purchased through your UNVERFERTH dealer.

**NOTE:** Hydraulic hoses are not supplied with auger. The hoses must have 3/4-16 J.I.C. female swivel ends to attach to 90° elbows on the auger. Hoses less than 1/2" in diameter can create operating complications in some situations, and should not be used. Minimum 1/2" hose diameter is recommended.

**Step 3: Attach Auger To Truck (continued)**

**Hydraulic Diagram**

**Diagram A -- One-Way System (Open-Center System)**

\* DARK LINES INDICATE TRUCK AUGER PIPING

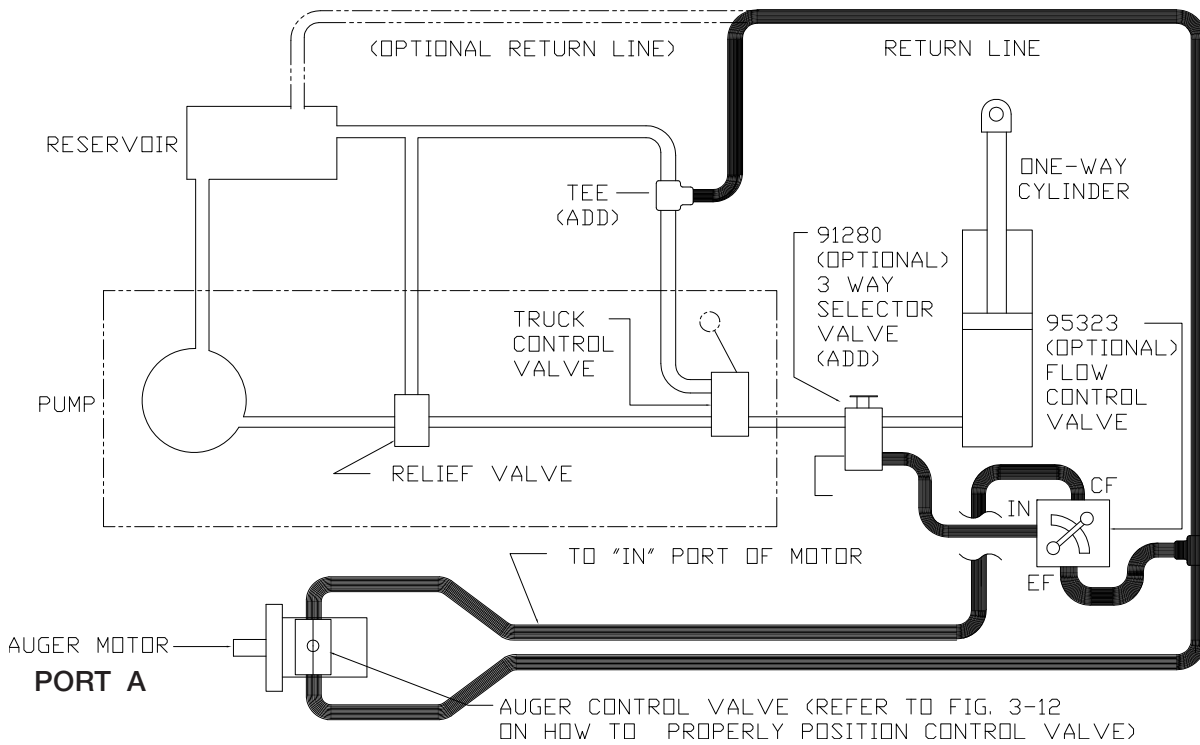

OM-01377S

**Step 3: Attach Auger To Truck (continued)**

**Hydraulic Diagram (continued)**

**Diagram B -- Two-Way System (Open-Center System)**

\* DARK LINES INDICATE TRUCK AUGER PIPING

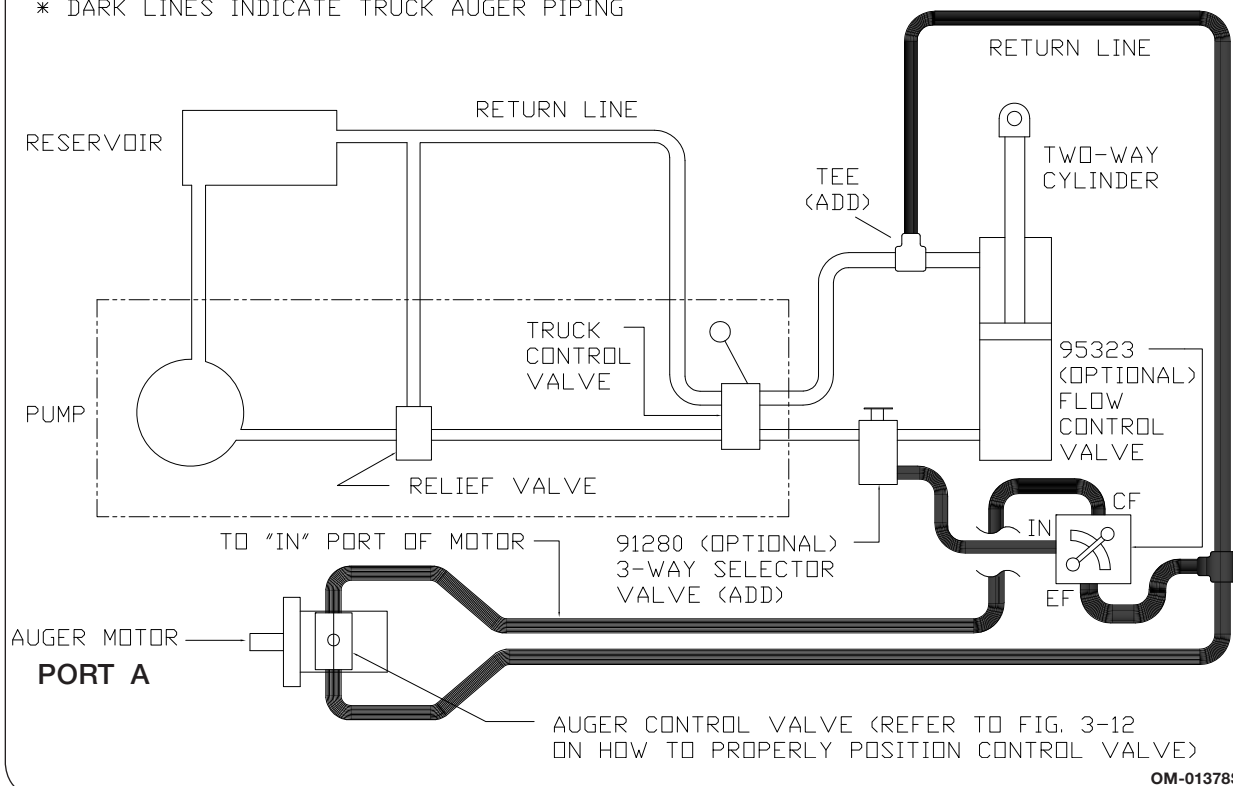

**Step 3: Attach Auger To Truck (continued)**

**Hydraulic Diagram (continued)**

**Diagram C -- One-Way System (Closed-Center System)**

\* DARK LINES INDICATE TRUCK AUGER PIPING

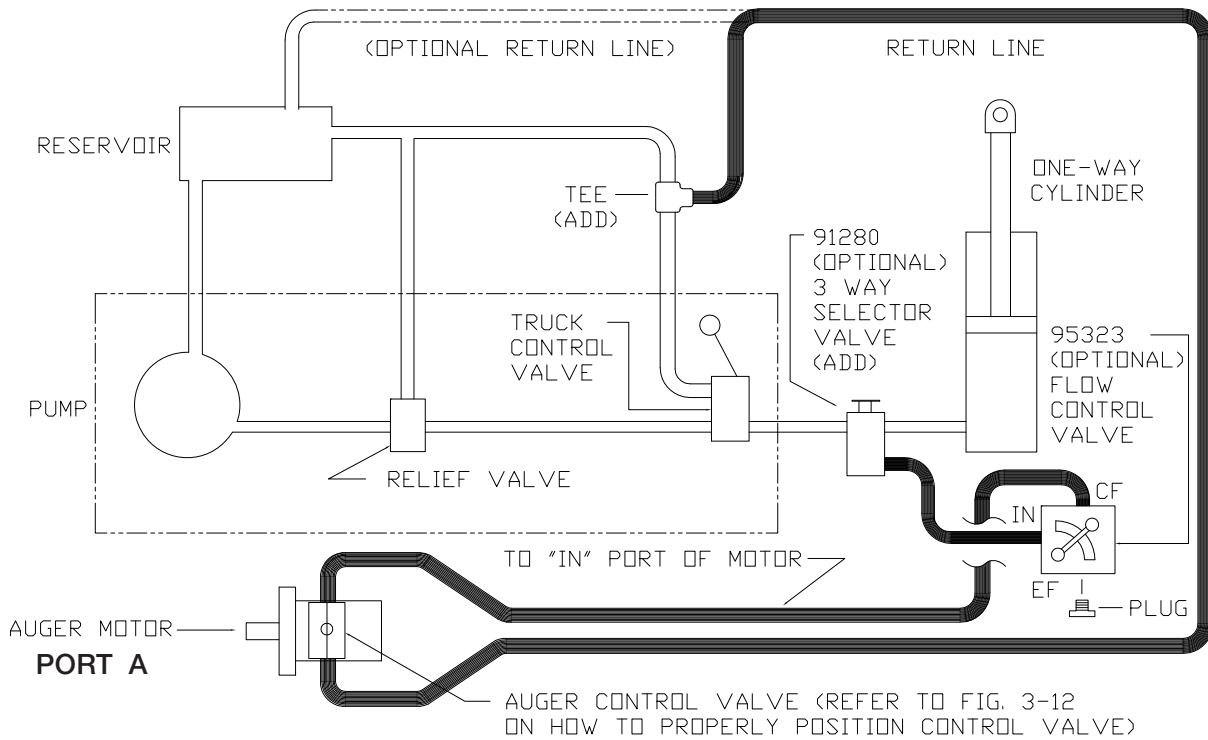

OM-01379S

**Step 3: Attach Auger To Truck (continued)**

**Hydraulic Diagram (continued)**

**Diagram D -- Two-Way System (Closed-Center System)**

\* DARK LINES INDICATE TRUCK AUGER PIPING

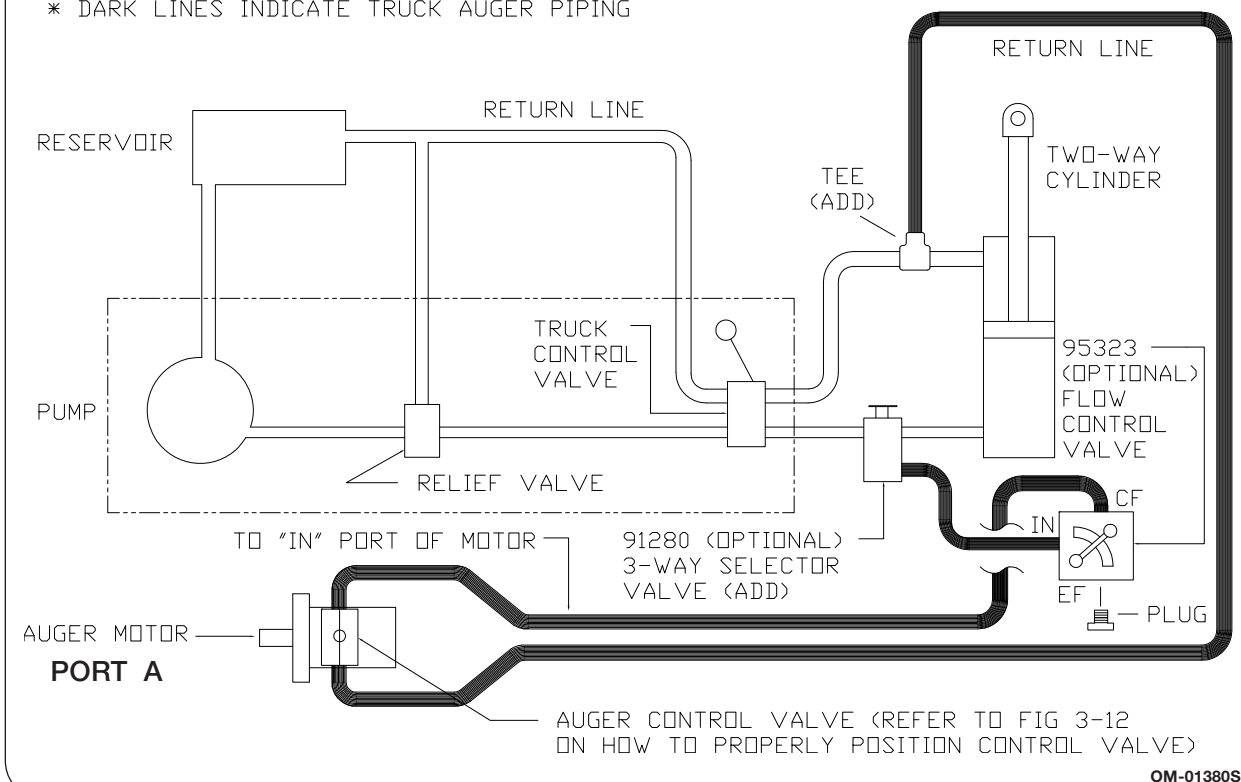

OM-01380S

**Step 3: Attach Auger To Truck (continued)**

NOTE: Refer to "Connecting Hydraulics To Auger With Steel Flighting".

**Connecting Hydraulics To Auger  
With Steel & Bristle Flighting (Right-Hand)**

NOTE: For best performance of auger, be sure valve is positioned as shown in FIG. 2-12.

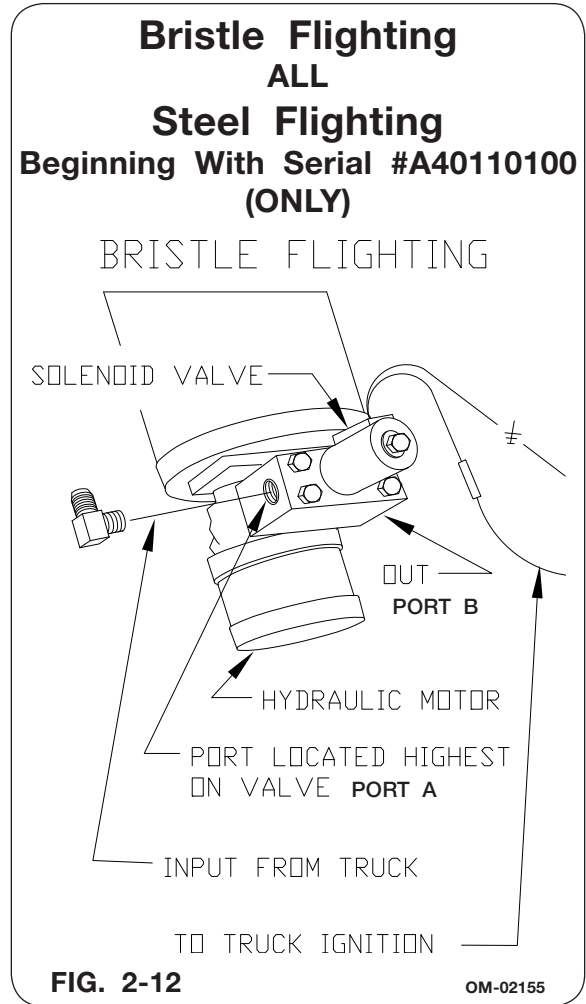

## Step 3: Attach Auger To Truck (continued)

### **WARNING**

- HIGH-PRESSURE FLUIDS CAN PENETRATE THE SKIN AND CAUSE SERIOUS INJURY OR DEATH. USE CARDBOARD OR WOOD TO DETECT LEAKS IN THE HYDRAULIC SYSTEM. SEEK MEDICAL TREATMENT IMMEDIATELY IF INJURED BY HIGH-PRESSURE FLUIDS.
- RELIEVE THE HYDRAULIC SYSTEM OF ALL PRESSURE BEFORE ADJUSTING OR SERVICING. SEE THE HYDRAULIC POWER UNIT OPERATOR'S MANUAL FOR PROPER PROCEDURES.

### **IMPORTANT**

- *To obtain the correct rotation on the auger flight, connect the hydraulic input hose from the truck to the port marked "IN" on the solenoid and the hydraulic return hose to the port on the opposite side of the solenoid.*
- *After hydraulic installation is complete, the system must be purged to prevent damage or rapid movement. Refer to power unit manual for proper purging procedures.*

**NOTE:** When installing hydraulics be sure the bed is lowered to relieve all the pressure.

28. Install hydraulic components (furnished by customer) to truck's hydraulic system. Refer to the following diagrams on pages 2-18 and 2-21 for proper installation.

#### **OPEN-CENTER**

- DIAGRAM A: ONE-WAY SYSTEM
- DIAGRAM B: TWO-WAY SYSTEM

#### **CLOSED-CENTER**

- DIAGRAM C: ONE-WAY SYSTEM
- DIAGRAM D: TWO-WAY SYSTEM

**NOTE:** Diagrams are shown with the optional selector valve (Unverferth #91280) installed into the system. This valve (or similar) must be used on a single control system (with one-way or two-way hydraulics) to control system function. The selector valve (91280) may be purchased through your UNVERFERTH dealer.

**NOTE:** Hydraulic hoses are not supplied with auger. The hoses must have 3/4-16 J.I.C. female swivel ends to attach to 90° elbows on the auger. Hoses less than 1/2" in diameter can create operating complications in some situations, and should not be used. Minimum 1/2" hose diameter is recommended.

**Step 3: Attach Auger To Truck (continued)**

**Hydraulic Diagram (continued)**

**Diagram A -- One-Way System (Open-Center System)**

\* DARK LINES INDICATE TRUCK AUGER PIPING

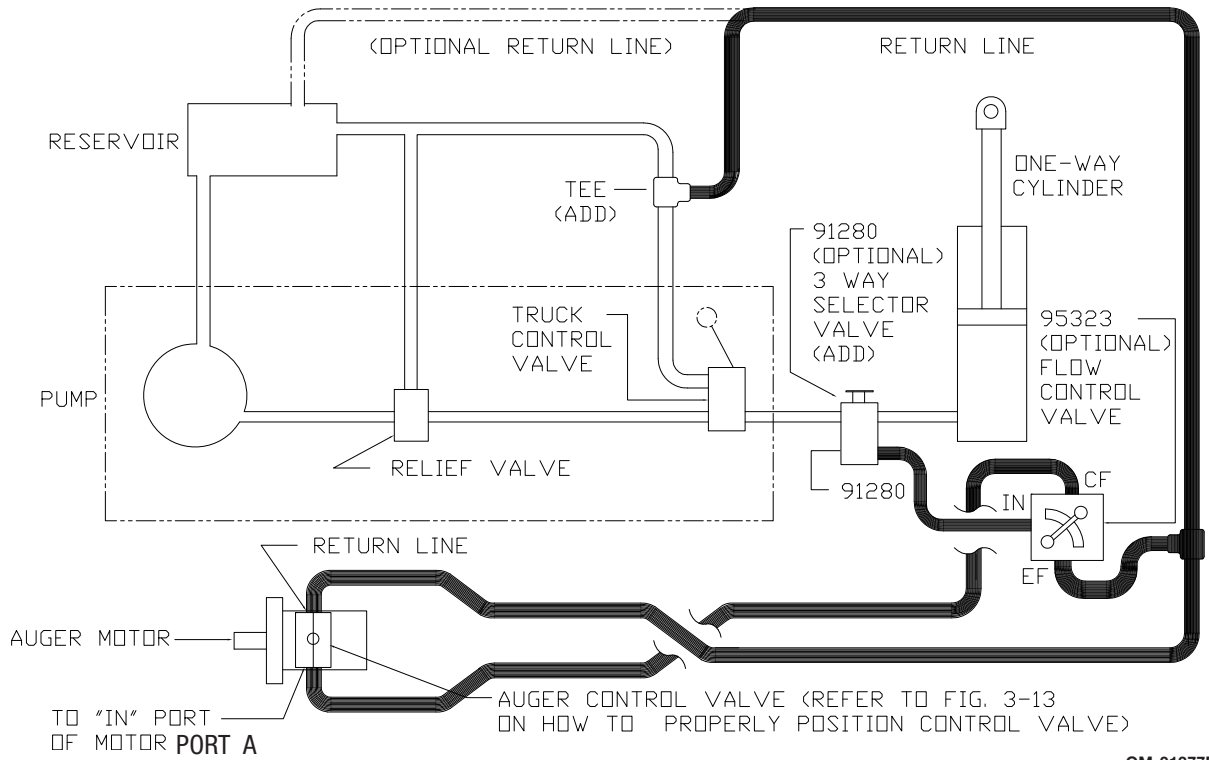



**Step 3: Attach Auger To Truck (continued)**

**Hydraulic Diagram (continued)**

**Diagram B -- Two-Way System (Open-Center System)**

\* DARK LINES INDICATE TRUCK AUGER PIPING

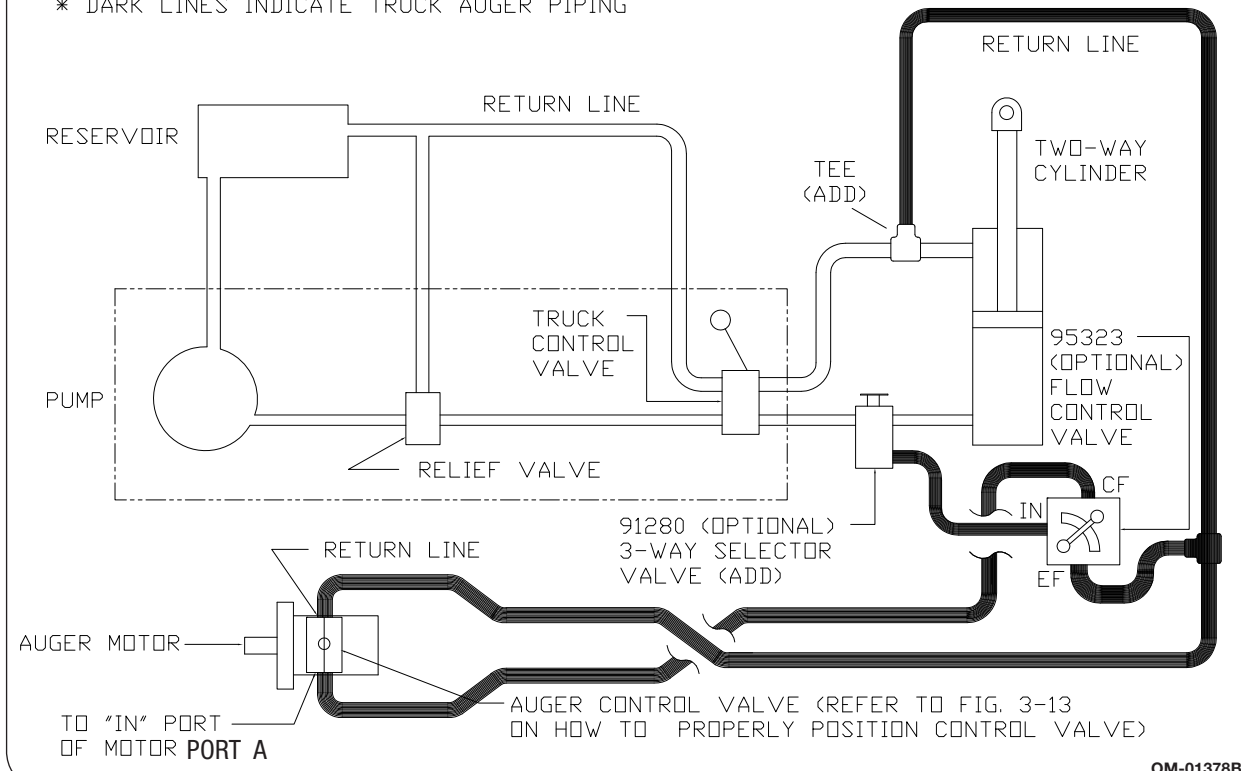

**Step 3: Attach Auger To Truck (continued)**

**Hydraulic Diagram (continued)**

**Diagram C -- One-Way System (Closed-Center System)**

\* DARK LINES INDICATE TRUCK AUGER PIPING

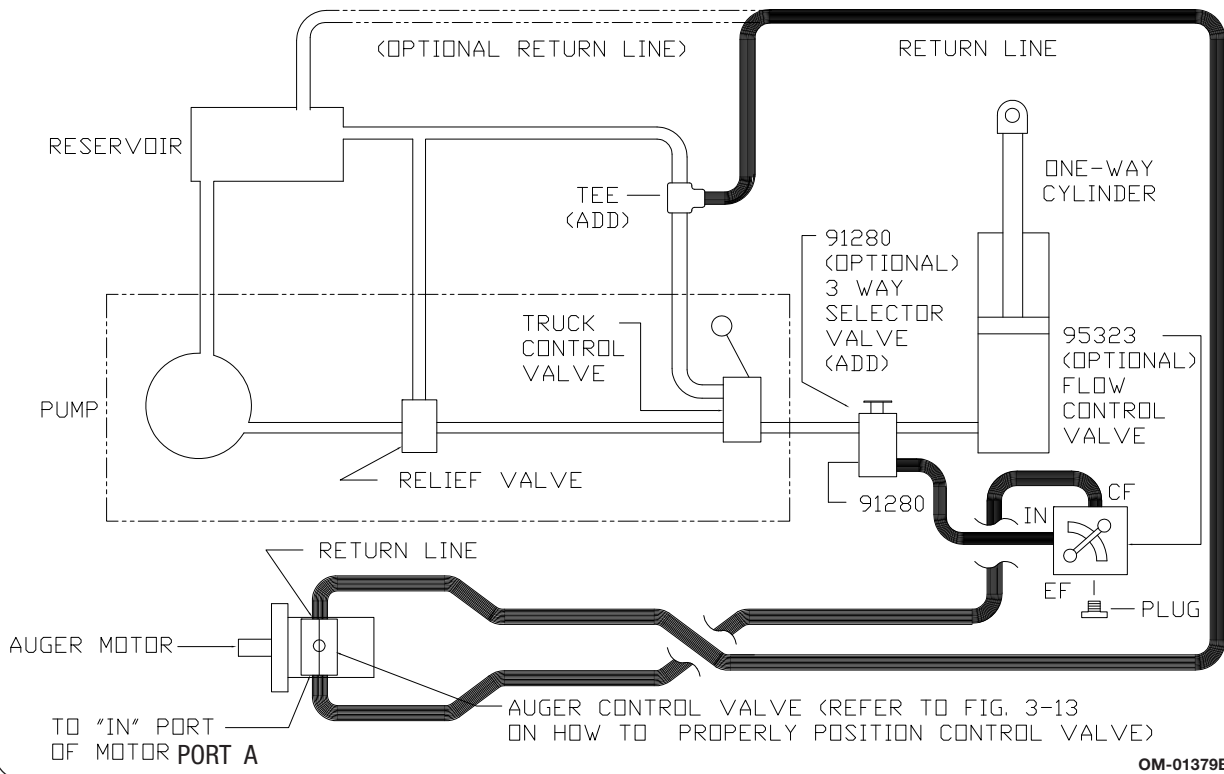

**Step 3: Attach Auger To Truck (continued)**

**Hydraulic Diagram (continued)**

**Diagram D -- Two-Way System (Closed-Center System)**

\* DARK LINES INDICATE TRUCK AUGER PIPING

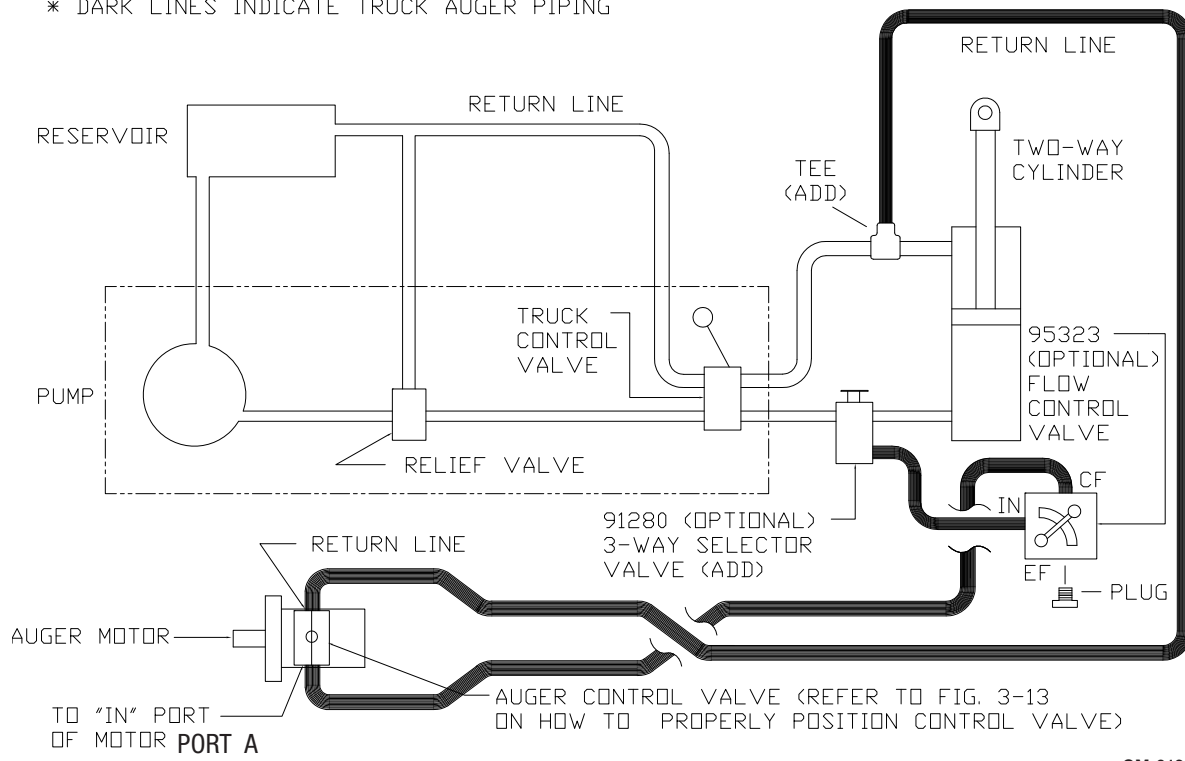

OM-01380B

**Step 3: Attach Auger To Truck (continued)****Flow Control Valve**

Trucks having high capacity hydraulic systems with 18 GPM flow and higher, may cause your auger to run too fast, resulting in:

- A. Excess vibration.
- B. Excess wear
- C. Loss of performance

To eliminate these problems, an optional adjustable flow control valve (#95323) is offered through your Unverferth dealer for installation into the auger hydraulic system. This valve will allow the operator to adjust flow to obtain the recommended operating speed of 450 to 600 RPM.

To install control valve, refer to the tables below and follow the appropriate plumbing diagram. Contact your local dealer to identify which system your truck uses. Refer to the plumbing diagrams for hook-up.

<b>Connecting Hydraulics To Auger With Steel &amp; BRISTLE Flighting</b>		
Diagram	Hydraulic System	Page
A	One-Way/Open-Center	2-18
B	Two-Way/Open-Center	2-19
C	One-Way/Closed-Center	2-20
D	Two-Way/Closed-Center	2-21

**SETTING AUGER SPEED:**

- A. Set flow control valve approximately 1/2 way on the flow indicator (lock into position).
- B. Start the oil flow and run the auger to check the auger speed. The flighting should run smooth, not lag or fluctuate in speed, adjust speed control valve if necessary.

## Step 3: Attach Auger To Truck (continued)

**NOTE:** When auger is loaded with material, the auger should not stall. Adjust the speed to allow for smooth even feed of material through the tube.

### Electrical Components

1. Detach the truck end connector of the wiring harness and connect it to the truck's electrical system as shown in FIG. 2-14.

**NOTE:** Be sure male end of connector is attached to the ground wire (  $\perp$  ) of truck as shown.

### IMPORTANT

- It is recommended that a 5 Amp. fuse circuit and 18 Ga. (min.) wire leads be used.

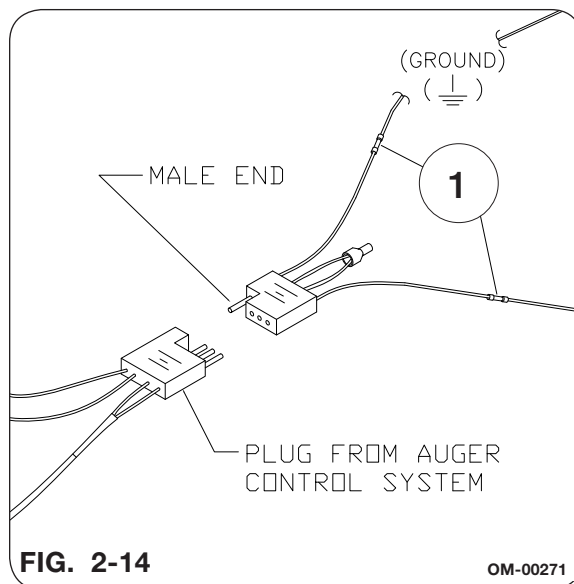

**Notes**

## **SECTION III**

# **Operation**

General Information.....	3-2
Preparing Truck.....	3-2
Attaching Auger To Truck .....	3-3
Removing The Auger From The Truck.....	3-5
Before Transporting .....	3-5
Transporting.....	3-6
Operating Auger .....	3-7
Performance .....	3-8

### General Information

Thoroughly read this OPERATIONS section. Acquaint yourself with the adjustments required to obtain efficient and trouble-free operations.

#### **WARNING**

- **FALLING OR LOWERING EQUIPMENT CAN CAUSE SERIOUS INJURY OR DEATH. KEEP EVERYONE AWAY FROM EQUIPMENT WHEN SUSPENDED, RAISING, OR LOWERING.**
- **FALLING OBJECTS CAN CAUSE SERIOUS INJURY OR DEATH. DO NOT WORK UNDER THE MACHINE AT ANY TIME WHILE BEING HOISTED. BE SURE ALL LIFTING DEVICES AND SUPPORTS ARE RATED FOR THE LOADS BEING HOISTED. THESE ASSEMBLY INSTRUCTIONS WILL REQUIRE SAFE LIFTING DEVICES UP TO 500 LBS. SPECIFIC LOAD RATINGS FOR INDIVIDUAL LOADS WILL BE GIVEN AT THE APPROPRIATE TIME IN THE INSTRUCTIONS.**
- **EYE PROTECTION AND OTHER APPROPRIATE PERSONAL PROTECTIVE EQUIPMENT MUST BE WORN WHILE SERVICING IMPLEMENT.**
- **KEEP HANDS CLEAR OF PINCH POINT AREAS.**

#### **IMPORTANT**

- *Know and understand all safety rules before operating or servicing this machine.*

### Preparing Truck

Before operating unit refer to the truck operator's manual for information concerning safe methods of operation, hydraulics, electrical system, tire inflation, and truck weights.

Check truck brakes and transport lights. Make sure they are in proper working order.

Check truck hydraulic oil reservoir and add oil if needed.

Be sure that truck hydraulic system supplies at least 8 G.P.M. at 1000 P.S.I. and that the electrical hook-up is a 12 Volt D.C. system with a 5 Amp fuse.



## Attaching Auger To Truck

1. Move the truck into position in front of the truck auger. Shut off the engine and lock the brakes on the truck.

### IMPORTANT

- Use good judgement when backing, be sure all personnel are clear of area.

2. Using a hoist, or secure lifting device, with a minimum capacity of 500 lbs. raise unit into position on mounting brackets (on back of truck). Secure into position with two 1/2 x 3 1/8" clevis pin (91362) and hairpin cotter (95959) (FIG. 3-1).

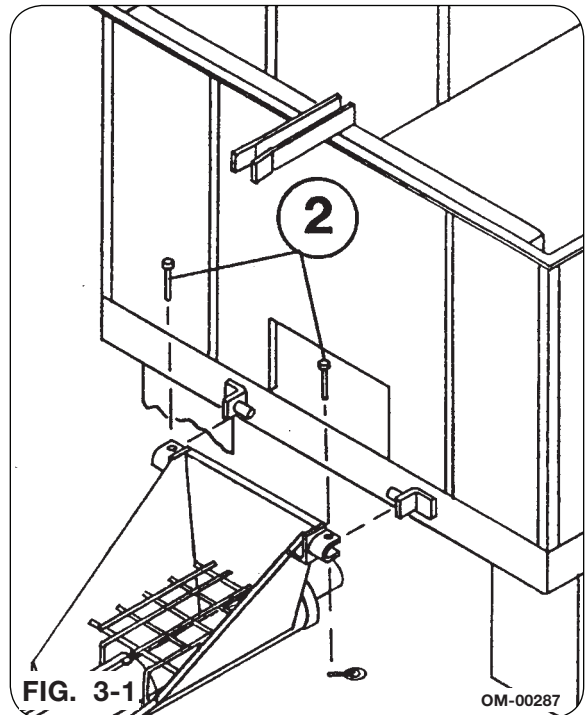

3. Using blocks or jack stand, position unit level with ground.
4. Attach the winch cable and safety cable to the ears on frame at top rear of truck bed (FIG. 3-2).

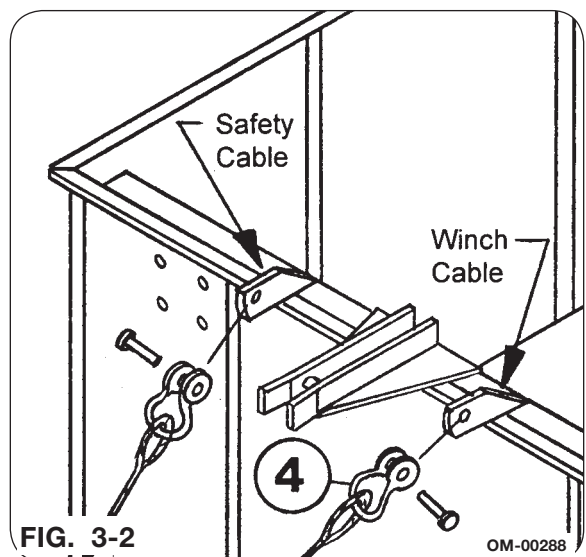

### Attaching Auger To Truck (continued)

**NOTE:** Be sure that the cables are properly routed and all kinks and twists are removed before attaching to the mounting frame. Also check to make sure that the safety cable is secured to the auger tube properly and that the winch cable is secure to the winch.

#### **IMPORTANT**

- *If all the kinks and twists are not removed before installing the cables into position, cable failure may occur.*

5. Connect the electrical wiring plug to the truck electrical system.

**NOTE:** Refer to the ASSEMBLY section for wiring hook-up.

#### **⚠ WARNING**

- **HIGH-PRESSURE FLUIDS CAN PENETRATE THE SKIN AND CAUSE SERIOUS INJURY OR DEATH. USE CARDBOARD OR WOOD TO DETECT LEAKS IN THE HYDRAULIC SYSTEM. SEEK MEDICAL TREATMENT IMMEDIATELY IF INJURED BY HIGH-PRESSURE FLUIDS.**
- **RELIEVE THE HYDRAULIC SYSTEM OF ALL PRESSURE BEFORE ADJUSTING OR SERVICING. SEE THE HYDRAULIC POWER UNIT OPERATOR'S MANUAL FOR PROPER PROCEDURES.**

6. Connect the hydraulic lines from the truck to the valve on the motor. Be sure to relieve all the hydraulic pressure before disconnecting any lines or pipes on the truck hydraulic system.

**NOTE:** Refer to the ASSEMBLY section for hydraulic hook-up.

After mounting and making all the necessary connections between the truck and the auger, check the following:

7. Recheck all the clamp rings, screws and pivot nuts for tightness. This should be done periodically as a preventative measure.
8. Make sure all the electrical wires and hydraulic hoses are properly routed and secured into position to prevent pinching and binding. Check that all connections are properly tightened to prevent leaks.

## Removing The Auger From The Truck

Lower the auger to the horizontal position and use above procedure in reverse when removing the auger from the truck.

## Before Transporting

**NOTE:** Empty auger before moving.

1. Lower the auger to the horizontal position.
2. Secure the telescopic spout to the upper tube (for transport) with klik pin (9093) provided (FIG. 3-3).

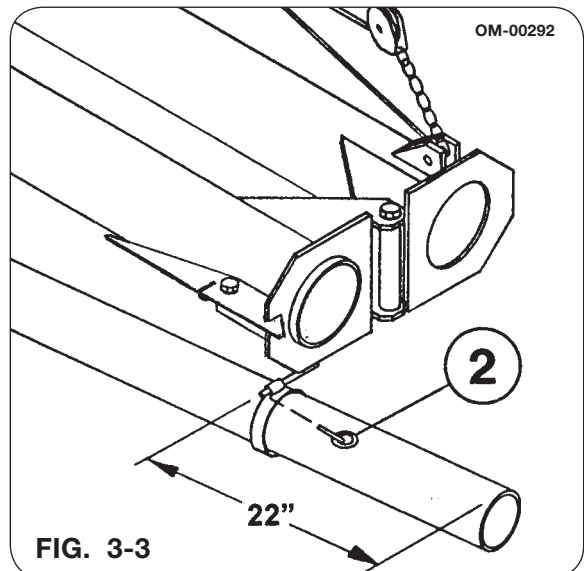

3. Lower the auger to the horizontal position, and unlatch the upper tube and fold into transport position. Secure with pin provided (FIG. 3-4).

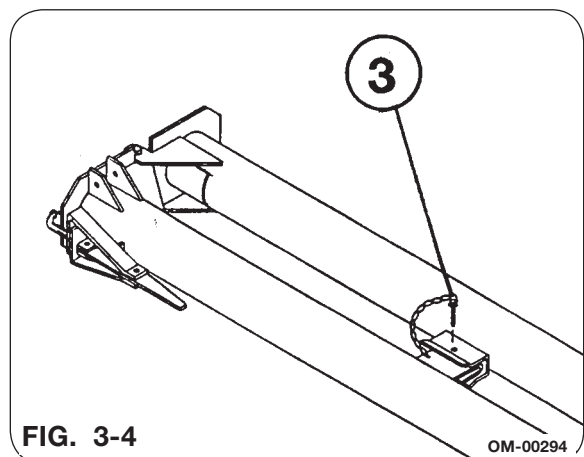

### Before Transporting (continued)

4. Winch the auger into the transport position and latch the auger to support the frame on back of the truck bed. Be sure the latch is fully engaged and install the transport lock to the auger tube (FIG. 3-5).

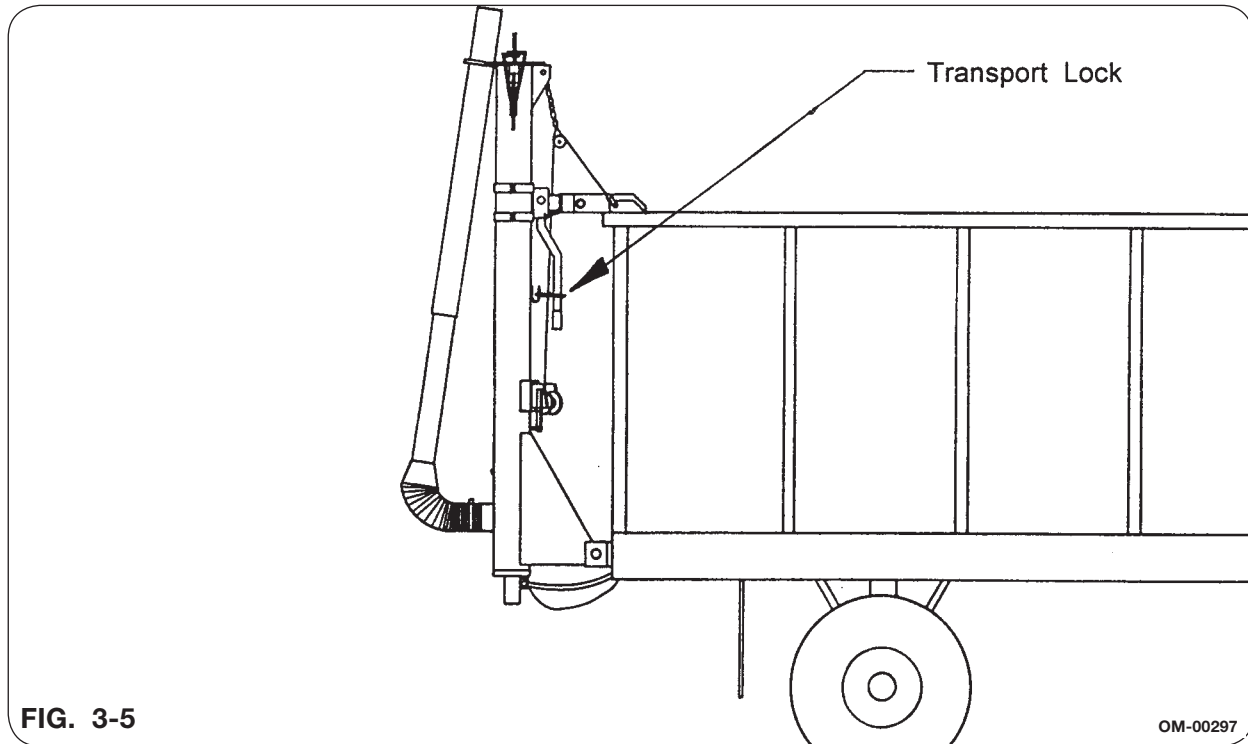

FIG. 3-5

OM-00297

### IMPORTANT

- If the latch will not line up or engage, adjust the latch on the lower tube to allow the latch to fully engage when the auger is raised into transport position.
- It is recommended to keep some tension on the winch cable while the auger is secured in the transport position.

### Transporting

### IMPORTANT

- Before unit is transported, be sure that the auger is properly mounted and secured into "Transport Position". Refer to "Before Transporting" in Operations Section.

Use caution when travelling, do not attempt to transport unit under low hanging tree branches, overhead telephone or electrical wires. Be aware of transport height of unit or damage could occur.

Comply with all state and local laws governing highway safety and regulations when moving equipment on public roads.

### Transporting (continued)

#### **WARNING**

- ALWAYS TRAVEL AT A SPEED WHICH PERMITS COMPLETE CONTROL OF TOWING VEHICLE AND IMPLEMENT.

#### **CAUTION**

- USE APPROVED ACCESSORY LIGHTS AND REFLECTORS WHEN TRANSPORTING AT NIGHT, DURING PERIODS OF POOR VISIBILITY, AND AS REQUIRED BY LOCAL LAW.

#### **IMPORTANT**

- *Check transport route clearance and refer to model specifications in truck operator's manual.*

For safe transporting of truck with auger the transport speed should never exceed 10 M.P.H. in the field or over rough terrain. Reduce transport speed to maintain full control at all times.

### Operating Auger

#### **WARNING**

- FALLING EQUIPMENT CAN CAUSE SERIOUS INJURY OR DEATH. BEFORE OPERATING WINCH, BE SURE THAT WINCH IS SECURELY INSTALLED TO THE LIFT FRAME CENTER, AND THE CABLE IS TIED TO THE WINCH AND LEFT HAND LEG WELDMENT. BE SURE TO FOLLOW THESE INSTRUCTIONS, AND THE OPERATING PROCEDURES PROVIDED WITH THE WINCH.

1. Back the truck into position in work area, allow approximately 20 feet clearance behind the truck. Shut-off engine and lock brakes on truck.
2. Lower auger to a horizontal position to unfold upper tube.
  - A. Release transport lock (FIG. 3-5) on latch handle.
  - B. Firmly grab the winch handle. Apply pressure to the winch and release the ratchet paw on the winch. Release the transport latch and winch the auger to the horizontal position.

#### **IMPORTANT**

- *Be sure to reengage the ratchet paw on the winch when winching is complete.*

3. Unfold the upper tube and lock into position.

### Operating Auger (continued)

4. Check to make sure on/off switch on the telescopic spout is "OFF"; and winch the auger tube into working position.
5. Back the truck into position and lock the brakes on the truck, and begin the flow of hydraulic fluid to the auger. Turn the switch "ON" and check that the auger flighting is turning in a forward direction. (Reverse hydraulic flow if necessary.)
6. Position the telescopic spout, open the end gate on the truck, and flick the switch to the "ON" position.

**NOTE:** To control the flow of material into the auger, adjust the flow control gate inside the hopper.

### IMPORTANT

- *In order to maintain proper flow through the discharge spout, we recommend the spout be held at no less than 30 degrees to the horizon during operations. A more shallow angle could plug the down spout resulting in damage to the equipment.*
7. Close the truck end gate just before seeding equipment is full and empty out the auger completely. Shut-off the power to the auger, lower the truck bed, and open the clean-out door on the auger to remove the final excess material.
  8. Upon completion, secure the telescopic spout. Lower the tube to the horizontal position and fold the upper tube. See "Before Transporting" in Operations Section.

**NOTE:** Use pressurized water to wash out the auger and hopper after use with fertilizer. See SERVICE section.

### Performance

**NOTE:** Many grain augers are run too fast. This is usually the result of modern hydraulic systems which provide high flow (18 to 40 G.P.M.) at the accessory outlets. When adjustment is provided, the flow should be reduced to 12 to 18 G.P.M. The G.P.M. can also be reduced by installing the optional control valve (95323). The lower flow rates will result in optimum performance of the auger, produce less harm to the material handled and provide longer wear life of the flighting.

When the auger speed is too fast it may cause severe vibration, damage or premature wear of flighting and tube. The material handled may incur more damage while the rate of discharge may actually be reduced!

# **SECTION IV**

# **Maintenance**

Lubrication	
Upper Tube Bearing.....	4-2
Lower Tube Bearing .....	4-2
Swivel Clamps .....	4-2
Miscellaneous Lube Points .....	4-2
Storage/Maintenance .....	4-3
Complete Torque Chart .....	4-4
Hydraulic Fittings - Torque and Installation .....	4-4
Troubleshooting	
Auger Will Not Turn Over Or Develop Proper Speed/Torque.....	4-5
Auger Creeps When Spout Switch Is Shut-Off.....	4-5
Auger Is Turning In Wrong Direction .....	4-6
Oil Heat Excessively .....	4-6
Pump/Motors/Seals Blow - Shaft/Housing Breaks - Hose Burst.....	4-6
Dead Battery .....	4-6
If Switch Does Not Operate Auger Motor .....	4-7
Electrical Specifications.....	4-7

## Lubrication

Lubricate with an SAE multi-purpose grease. All fittings must be free from dirt and paint to insure entry of lubricant inside bearing.

### Upper Tube Bearing

Lubricate this bearing every 100 hours of operation and at the end of each season, before storage. Use only one stroke of grease per bearing.

### CAUTION

- DO NOT USE A HIGH-PRESSURE GREASE GUN TO LUBRICATE THIS BEARING, AS DAMAGE TO BEARING SEAL COULD OCCUR.

**NOTE:** Excessive lubrication of this bearing will result in premature failure.

### Lower Tube Bearing

Grease once per season, use only one stroke of grease.

### Swivel Clamps

Grease once per season (or more frequently as required).

### Miscellaneous Lube Points

Oil or grease periodically (or as needed) the following:

- Hinge for Clean-Out Door
- Wire Rope Sheave
- Pivot Pin Bushing
- Winch - Gears/Bearings/Handle



### Storage/Maintenance

Your auger is an important investment. Spend a little time to protect it from destructive rust and corrosion. You will be repaid in longer service life and better performance.

**Do the following after use:**

1. Clean-out the auger / hopper. Use pressurized water to wash out the auger and hopper after using fertilizers.
2. Wipe off the following:
  - hydraulic valve
  - motor
  - hydraulic hoses and fittings
3. Check the following:
  - Winch and safety cable for wear and looseness
  - Spout clamp rings
  - Hopper mounting bolts for proper adjustment
  - Cable ties for tightness
  - Valve, motor, hoses, and fittings for leaks, etc.

**Do the following before placing the auger in storage:**

- Repaint any chipped or scraped areas
- Inspect for damaged or worn parts and replace before next season
- Store unit inside, away from livestock

**NOTE:** Be sure the winches and cables are not damaged or worn. Take extra precaution when inspecting, not doing so could result in failure of the winch.

**Complete Torque Chart - Capscrews - Grade 5**

**IMPORTANT**

- Grade 5 capscrews can be identified by three radial dashes on head.
- For wheel torque requirements, refer to *Wheels and Tires*.
- Tighten U-bolts evenly and equally to have the same number of threads exposed on each end.

SIZE	FOOT POUNDS	NEWTON METERS	SIZE	FOOT POUNDS	NEWTON METERS
1/4-20	8-10	11-13	3/4-10	200-220	270-300
1/4-28	9-11	12-15	3/4-16	210-230	285-310
5/16-18	15-17	20-23	7/8-9	330-350	425-475
5/16-24	17-19	23-26	7/8-14	360-380	460-515
3/8-16	25-28	34-38	1-8	500-525	675-710
3/8-24	28-31	38-42	1-14	540-560	730-760
7/16-14	40-45	54-61	1 1/8-7	600-635	815-860
7/16-20	45-50	61-68	1 1/8-12	665-700	920-950
1/2-13	62-68	84-92	1 1/4-7	850-895	1150-1215
1/2-20	68-75	92-102	1 1/4-12	940-990	1275-1340
9/16-12	90-98	22-133	1 3/8-6	1125-1175	1525-1590
9/16-18	100-110	134-148	1 3/8-12	1280-1335	1735-1810
5/8-11	120-135	162-183	1 1/2-6	1500-1560	2035-2115
5/8-18	124-137	168-186	1 1/2-12	1685-1755	2285-2380

**Hydraulic Fittings - Torque and Installation**

**SAE FLARE CONNECTION (J. I. C.)**

1. Tighten nut with finger until it bottoms the seat.
2. Using a wrench, rotate nut to tighten. Turn nut 1/3 turn to apply proper torque.

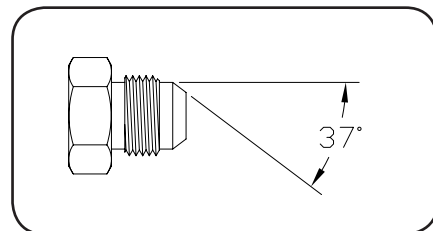

**SAE STRAIGHT THREAD O-RING SEAL**

1. Insure jam nut and washer are backed up to the back side of smooth portion of elbow adapter.
2. Lubricate o-ring -- VERY IMPORTANT!
3. Thread into port until washer bottoms onto spot face.
4. Position elbows by backing up adapter.
5. Tighten jam nut.

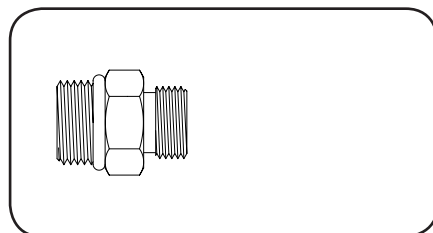

**Troubleshooting**

PROBABLE CAUSE	CORRECTION
<b>Auger Will Not Turn Over or Develop Proper Speed/Torque</b>	
Pump does not deliver sufficient pressure or volume	Check output and delivery-change/repair if necessary
Relief valve on truck sticking open	Clean and/or reset relief valve
Auger mechanism binding because of misalignment	Check for cause and correct
Auger jammed	Shut-off and lock-out power open clean-out door and remove excess material (make sure unload spout is clear)
Truck engine running too slow	Increase engine speed
Truck pump not producing minimum required flow and pressure	Check truck pump capacity and correct
Pump is worn	Repair or replace pump
Internal leak in controls or motor	Replace seals; repair or replace valves or motors
Air in system	Bleed system and tighten connections
Improper weight hydraulic oil	If conveyor starts slowly and speed increased after the oil heats up, oil is too heavy weight. If conveyor slows down after the oil heats up, oil is too light weight.
Solenoid block assembled backward. Electronic control will also work in reverse causing the switch to be on when the auger is not running.	Remove solenoid block from hydraulic motor, rotate 180° and reassemble. To insure the electric ON/OFF switch is working correctly (on is on/off is off), the input hose must go into the port marked "A" and the output hose must come out of the port marked "B"
<b>Auger Creeps When Spout Switch Is Shut-Off</b>	
Oil flow (G.P.M.) is too high	Decrease oil flow (not pressure) to hydraulic motor with use of flow control valve (Unverferth #95323). Flow must not exceed 12 G.P.M.
Hose diameter being used is too small	Replace with a larger I.D. hose (3/4" I.D. hose recommended)

**Troubleshooting** (continued)

PROBABLE CAUSE	CORRECTION
<b>Auger is Turning in Wrong Direction</b>	
Control valve on truck not set properly (if reversing valve is provided)	Reset
Incorrect piping between motor and direction control valve	Reverse piping connections
<b>Oil Heat Excessively</b>	
Too light weight in hot climate	Drain and refill with proper weight oil.
Oil too heavy weight	Use recommended weight oil.
Dirty oil	Drain, flush, and refill with clean oil and filter
Oil level too low	Fill to proper level
Relief valve pressure too high or low; does not operate	Adjust and repair or replace relief valve
Oil slipping through worn pump	Repair or replace pump
Hoses or valves too small	Use larger hoses or valves
Restricted lines or piping	Reroute lines to eliminate restrictions
Reservoir too small to provide adequate cooling	Replace with larger reservoir or install oil cooler
<b>Pump/Motors/Seals Blow - Shaft/Housing Breaks - Hose Burst</b>	
When a standard control valve is returned to neutral to stop or start a motor, sudden excess pressure is created which will break seals, tear off motor shafts, burst housing or hoses, (Especially at speed under load.) This sudden shock cannot be relieved through the primary relief valve in the system.	Avoid sudden rapid starting and stopping (or convert to a free wheeling control valve (on the truck) or a cushion valve may be installed)
<b>Dead Battery</b>	
Due to incorrect plumbing, the solenoid valve must be turned on to shut the hydraulic motor off	Check your plumbing according to the style of fighting you have refer to Set Up section

**Troubleshooting (continued)**

PROBABLE CAUSE	CORRECTION
<b>If Switch Does Not Operate Auger Motor</b>	
No voltage at plug	Check fuses / replace. Check source wiring connections
Voltage at plug -- NO continuity across switch	Replace switch
Voltage at plug, switch shows continuity -- NO voltage across solenoid	Check solenoid coil for short (coil should measure 6.0 on Ohm-meter)
Voltage at plug, continuity at switch and solenoid coil	Check the cable for continuity -- loosen connections / replace
Burned out solenoid	Replace solenoid
Poor ground connection	Properly ground solenoid to truck frame

Occasionally when an auger has been connected into an auxiliary hydraulic system, it may not operate or auger the material being handled. When hydraulic pressure and flow gauges are not available, it may be difficult to determine if there is a fault in the source, hydraulic system, or the auger. A convenient method of determining this is to connect the auger hydraulic hoses to another tractor system and check the operation. If, for example, the auger operates from the other tractor system but not from the original tractor there is a fault in the original tractor connection, or the original tractor system is not adequate. If the auger fails to operate; however, there is probably a fault with the auger control valve, motor, or the auger itself. In this case, refer to the troubleshooting guide.

**Electrical Specifications**

SOURCE: 12 Volt D.C. 5 Amp.	SOLENOID COIL: 12 Volt D.C. 2.0 Amp.	WIRE: 18 GA. (min) recommended for long length
--------------------------------	---	--

**Notes**

# SECTION V

# Parts

**Please visit [www.unverferth.com/parts/](http://www.unverferth.com/parts/) for the most current parts listing.**

Lower Auger Components.....	5-2
Upper Auger Components.....	5-4
Hopper and Mounting Components.....	5-6
Transport Latch.....	5-8
Winch and Safety Cable.....	5-9
Wiring Harness & Valves.....	5-10

**Lower Auger Components**

Please visit [www.unverferth.com/parts/](http://www.unverferth.com/parts/) for the most current parts listing.

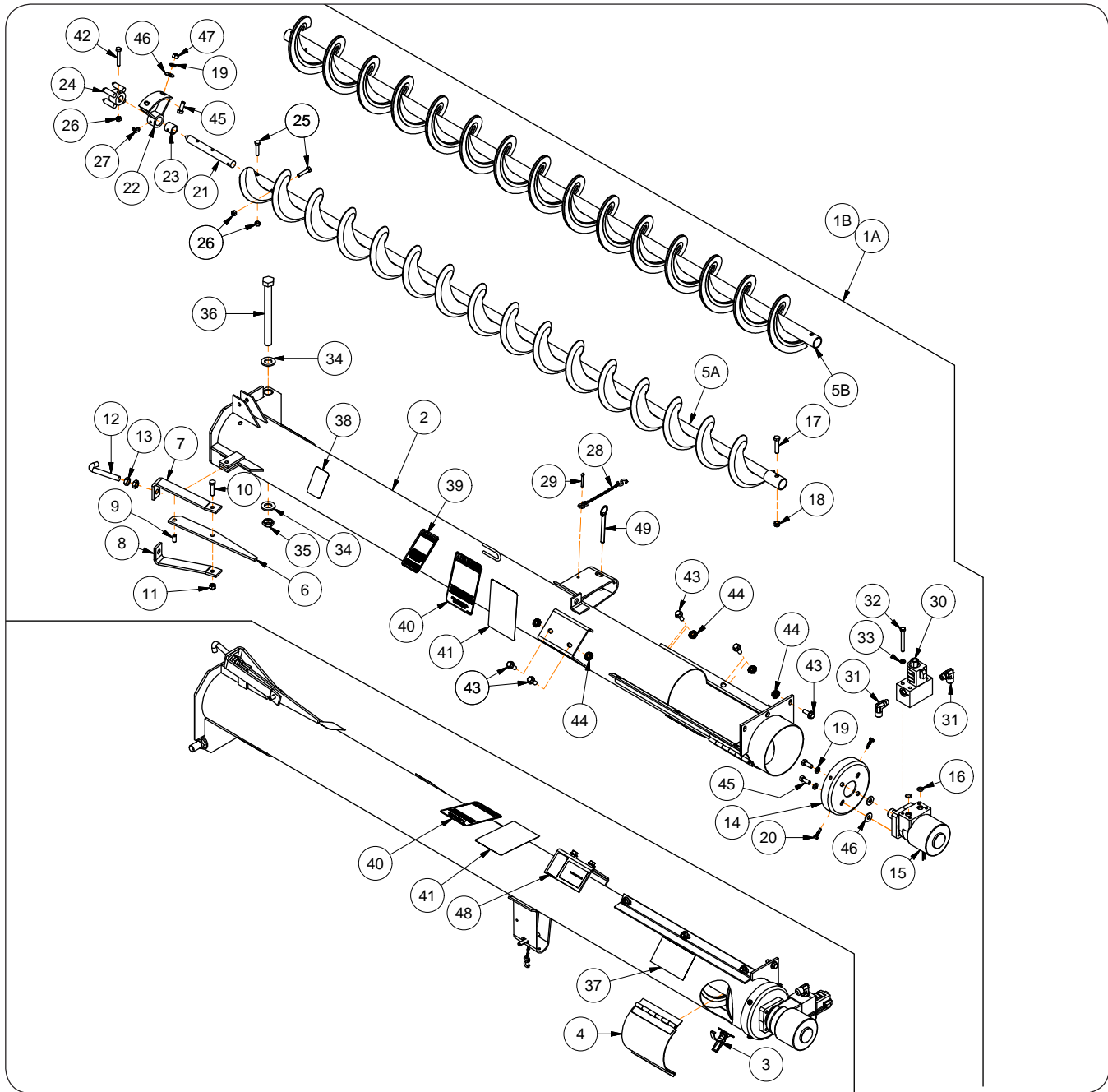

ITEM	PART NO.	DESCRIPTION	QTY	NOTES	
1A	22844	Lower Tube Bundle w/Steel Flighting	1		
1B	21122	Lower Tube Bundle w/Brush Flighting	1		
2	20917	Lower Tube Weldment	1		
	3	9220	Draw Latch	1	
	4	2537	Clean Out Door Subassy	1	
5A	22840B	Lower Flighting Weldment (Steel RH)	1	Beginning with Serial #A40110100	
	21564B	Lower Flighting Weldment (Steel LH)		Prior to Serial #A40110099	
5B	20949	Lower Flighting Weldment (Brush)			



**Lower Auger Components**

Please visit [www.unverferth.com/parts/](http://www.unverferth.com/parts/) for the most current parts listing.

ITEM	PART NO.	DESCRIPTION	QTY	NOTES
6	2819	Lever	1	
7	21495	Outside Yoke Bar	1	
8	21496	Inside Yoke Bar	1	
9	91144-195	Spiral Pin 3/8" Dia. x 3/4	1	
10	9390-057	Capscrew 3/8-16UNC x 1 1/2	1	Grade 5
11	9398-012	Elastic Stop Nut 3/8-16UNC	1	
12	21501	Hook	1	
13	9395-010	Hex Jam Nut 1/2-13UNC	2	Grade 5
14	2865R	End Cap	1	
15	91604B	Hydraulic Motor 12GPM 1800psi	1	
	91687	Seal Kit (Repairs)	-	
16	91306	O-Ring	2	
17	9390-058	Capscrew 3/8-16UNC x 1 3/4	1	Grade 5
18	9928	Locknut 3/8-16UNC	1	
19	9404-021	Lock Washer 3/8"	6	
20	9512	Screw/Self Drill 1/4-14 x 1	4	
21	20897	Pin/Shaft 3/4" Dia. x 7 5/16	1	
22	20942	Hanger Bearing Weldment	1	
23	92221	Bearing 3/4" ID	1	
24	20943	Drive Collar Weldment	1	
25	9390-032	Capscrew 5/16-18UNC x 1 1/2	2	Grade 5
26	9807	Locknut 5/16-18UNC	3	
27	92917	Zerk 45°	1	
28	20955	Sash-Chain Sub Assembly w/S-Hooks	1	
29	9391-043	Cotter Pin 3/16" Dia. x 1 1/4	1	
30	95906	Solenoid Valve Assembly w/Block	1	
31	95908	90° Elbow 3/4-16 JIC Male x 9/16-18	2	
32	9390-037	Capscrew 5/16-18 UNC x 2 3/4	4	Grade 5
33	9404-019	Lock Washer 5/16"	4	
34	9405-104	Flat Washer 3/4 SAE	2	
35	9397-016	Elastic Jam Nut 3/4-16UNF	1	
36	20194	Capscrew 3/4-16UNF x 8"	1	Grade 5
37	98766	Decal WARNING (Rotating Auger)	1	
38	97048	Decal WARNING (Pinch Point)	1	
39	93551	Decal WARNING (High-Pressure Fluid)	1	
40	93558	Decal DANGER (Electrocution Hazard)	1	
41	93552	Decal DANGER (Entanglement w/Auger)	1	
42	9390-034	Capscrew 5/16-18UNC x 2	1	Grade 5
43	91262	Flange Screw 3/8-16UNC x 1	10	Grade 5
44	91263	Nut/Large Flange 3/8-16UNC	10	
45	9390-055	Capscrew 3/8-16UNC x 1	6	Grade 5
46	9405-076	Flat Washer 3/8" USS	6	
47	9394-006	Hex Nut 3/8-16UNC	2	
48	91605	Decal FEMA	1	
49	92233	Hitch Pin 3/8" Dia. x 3 1/2	1	



**Upper Auger Components**

Please visit [www.unverferth.com/parts/](http://www.unverferth.com/parts/) for the most current parts listing.

ITEM	PART NO.	DESCRIPTION	QTY.	NOTES
1A	22845	Upper Tube Bundle w/Steel Flighting	1	Beginning with Serial #A40110100
1B	21123	Upper Tube Bundle w/Brush Flighting	1	
2	20953	Upper Auger Tube Weldment	1	
3A	22839B	Upper Flighting Weldment (Steel RH)	1	Beginning with Serial #A40110100
	21563B	Upper Flighting Weldment (Steel LH)		Prior to Serial #A40110099
3B	20947	Upper Flighting Weldment (Brush)		
4	20821	Swivel Tube Weldment	1	
5	20933R	End Cap Weldment	1	
6	9735	Flange Bearing 3/4" ID	1	
7	21490	Latch Plate	1	
8	21491	Bushing	1	
9	94741	Torsion Spring LH Wound	1	
10	9390-110	Capscrew 1/2-13UNC x 3 3/4	1	Grade 5
11	9800	Locknut 1/2-13UNC	1	
12	9093	Klik Pin 3/16" Dia. x 1 9/16	1	
13	2844	Swivel Clamp 6" Assembly w/Grease Zerks	1	
14	9414	Swivel Clamp Band 6"	1	
15	9390-064	Capscrew 3/8-16UNC x 3 1/4	2	Grade 5
16	9928	Locknut 3/8-16UNC	2	
17	91160	Grease Zerk	2	
18	9512	Screw/Self Drill 1/4-14 x 1	4	
19	9390-067	Capscrew 3/8-16UNC x 4	4	Grade 5
20	92217	Compression Spring	4	
21	9928	Locknut 3/8-16UNC	6	
22	901607	UM Oval Decal	2	
23	9405-076	Flat Washer 3/8" USS	8	
24	901725	Decal Unverferth Logo (Gray)	2	
25	22994	Telescopic Spout Assembly 6" x 14'	1	
26	98060	Clamp/T-Bolt 6.5D NOM	1	
27	21081	Spout Clamp Weldment	1	
28	9390-005	Capscrew 1/4-20UNC x 1	1	
29	9404-017	Lock Washer 1/4"	1	
30	9394-002	Hex Nut 1/4-20UNC	1	

Hopper And Mounting Components

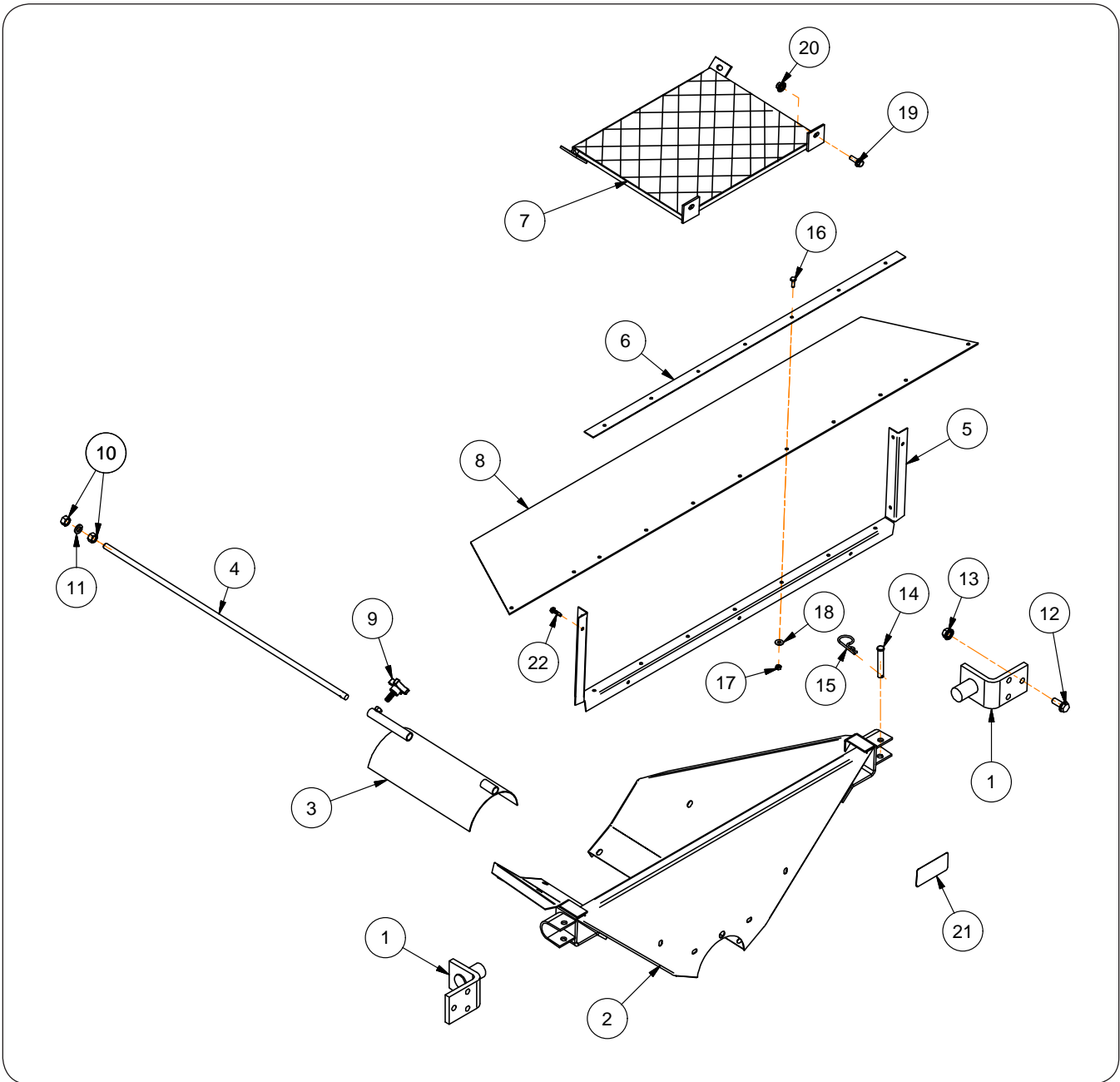

**Hopper And Mounting Components**

ITEM	PART NO.	DESCRIPTION	QTY.	NOTES
1	20936	Mounting Bracket	2	
2	20952	Hopper Weldment	1	
3	21079	Gate Weldment	1	
4	21103R	Gate Rod	1	
5	21109	Seal Mounting Angle	1	
6	21112	Seal	1	
7	21127	Guard	1	
8	21135	Hopper Seal	1	
9	92922	Knob	1	
10	9394-010	Hex Nut 1/2-13	2	
11	9404-025	Lock Washer 1/2"	1	
12	91266	Flange Bolt 1/2-13UNC x 1 1/4" Lg.	6	
13	91267	Flange Nut 1/2-13UNC	6	
14	91362	Clevis Pin 1/2 x 3 1/8" Lg.	2	
15	95959	Hairpin Cotter .1562" Dia. x 3	2	
16	9390-003	Capscrew 1/4-20UNC x 3/4" Lg.	11	
17	9394-002	Hex Nut 1/4-20UNC	12	
18	9405-064	Flat Washer 1/4"	11	
19	91262	Flange Screw 3/8-16UNC x 1" Lg.	4	
20	91263	Flange Nut 3/8-16UNC	4	
21	97961	Decal, CAUTION	1	
22	9512	Self-Driven Screw 1/4-14 x 1	5	

**Transport Latch**

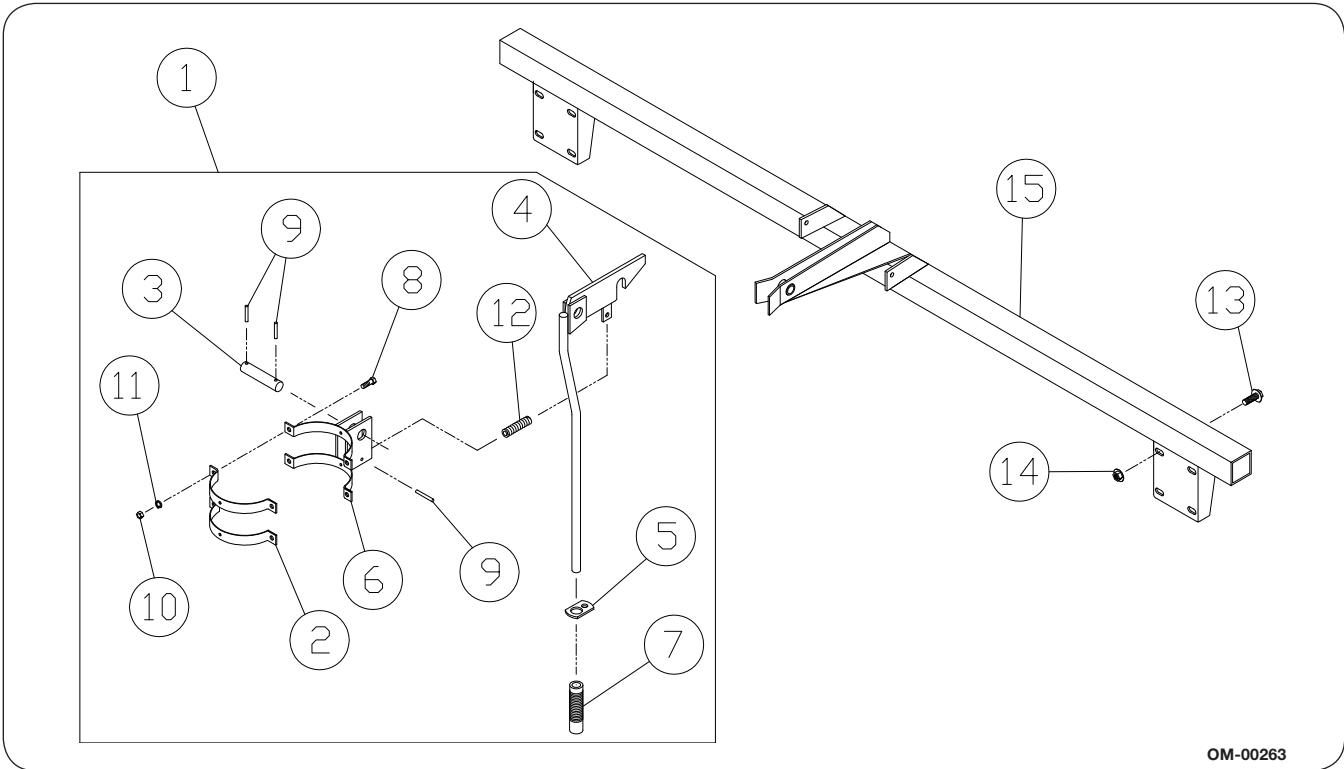

OM-00263

ITEM	PART NO.	DESCRIPTION
1	21105	Transport Latch Assembly
2	2745B	Strap
3	22471	Pin 1" x 2 5/8" Lg.
4	21091	Handle Weldment
5	21093	Plate
6	21097	Bracket Weldment
7	92928	Grip
8	9390-058	Capscrew 3/8-16 x 1 3/4" Lg.
9	91144-165	Spiral Pin 1/4 x 1 7/8" Lg.
10	9394-006	Hex Nut 3/8-16
11	9404-021	Lock Washer 3/8"
12	9475	Spring
13	91266	Flange Bolt 1/2-13 x 1 1/4" Lg.
14	91267	Flange Nut 1/2-13
15	21098	Frame Latch Weldment

**Winch And Safety Cable**

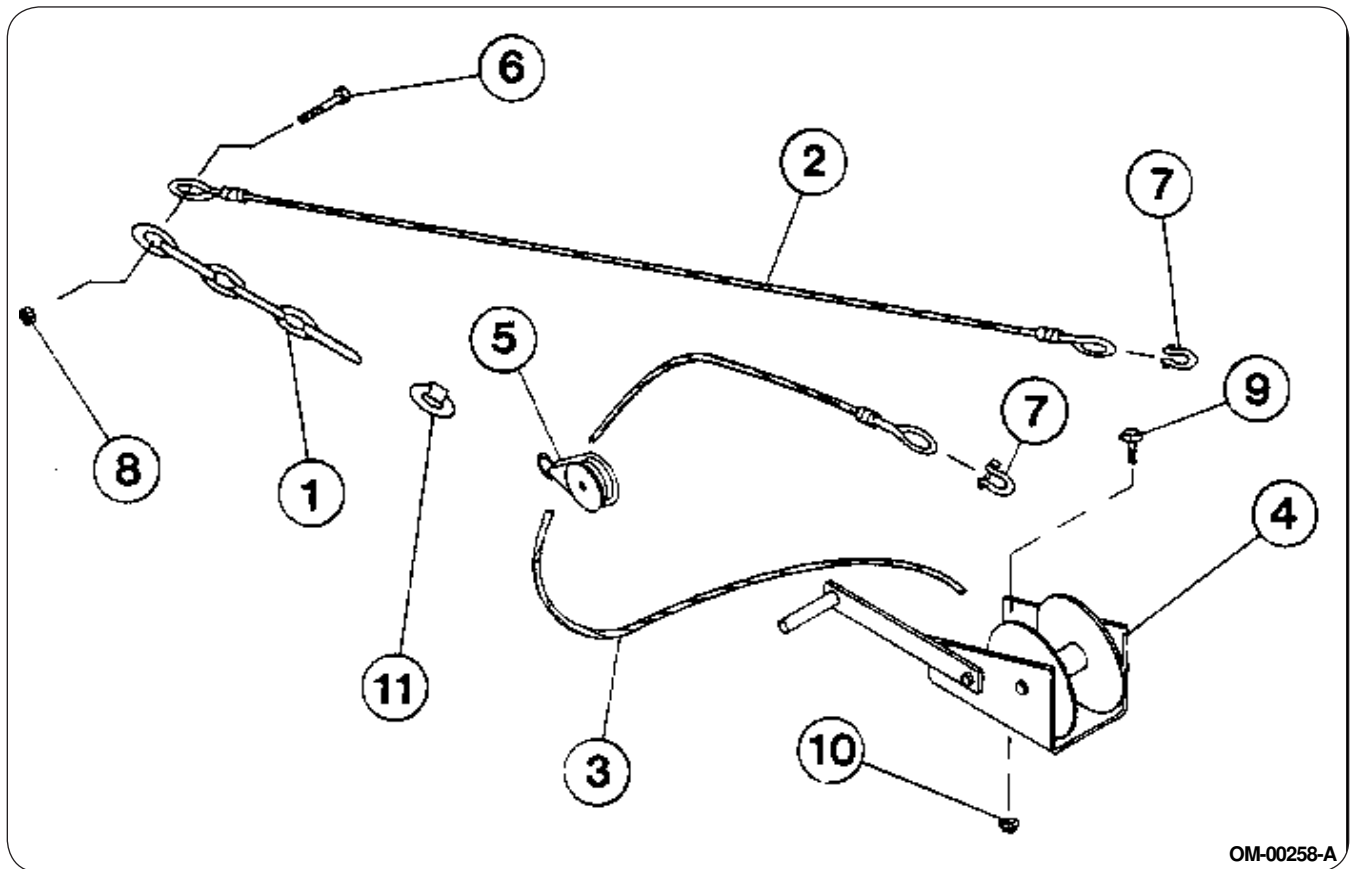

OM-00258-A

ITEM	PART NO.	DESCRIPTION
1	2829	Chain 5/0 (6 Links)
2	21119	Safety Cable (100" Lg.)
3	20017	Winch Cable (175" Lg.)
4	9501907	Winch
5	92459	Pulley
6	9390-058	Capscrew 3/8-16 x 1 3/4" Lg.
7	9515	Anchor Shackle
8	9928	Locknut 3/8-16
9	91262	Flange Screw 3/8-16 x 1" Lg.
10	91263	Flange Nut 3/8-16
11	91514	Quick Link

**Wiring Harness & Valves**

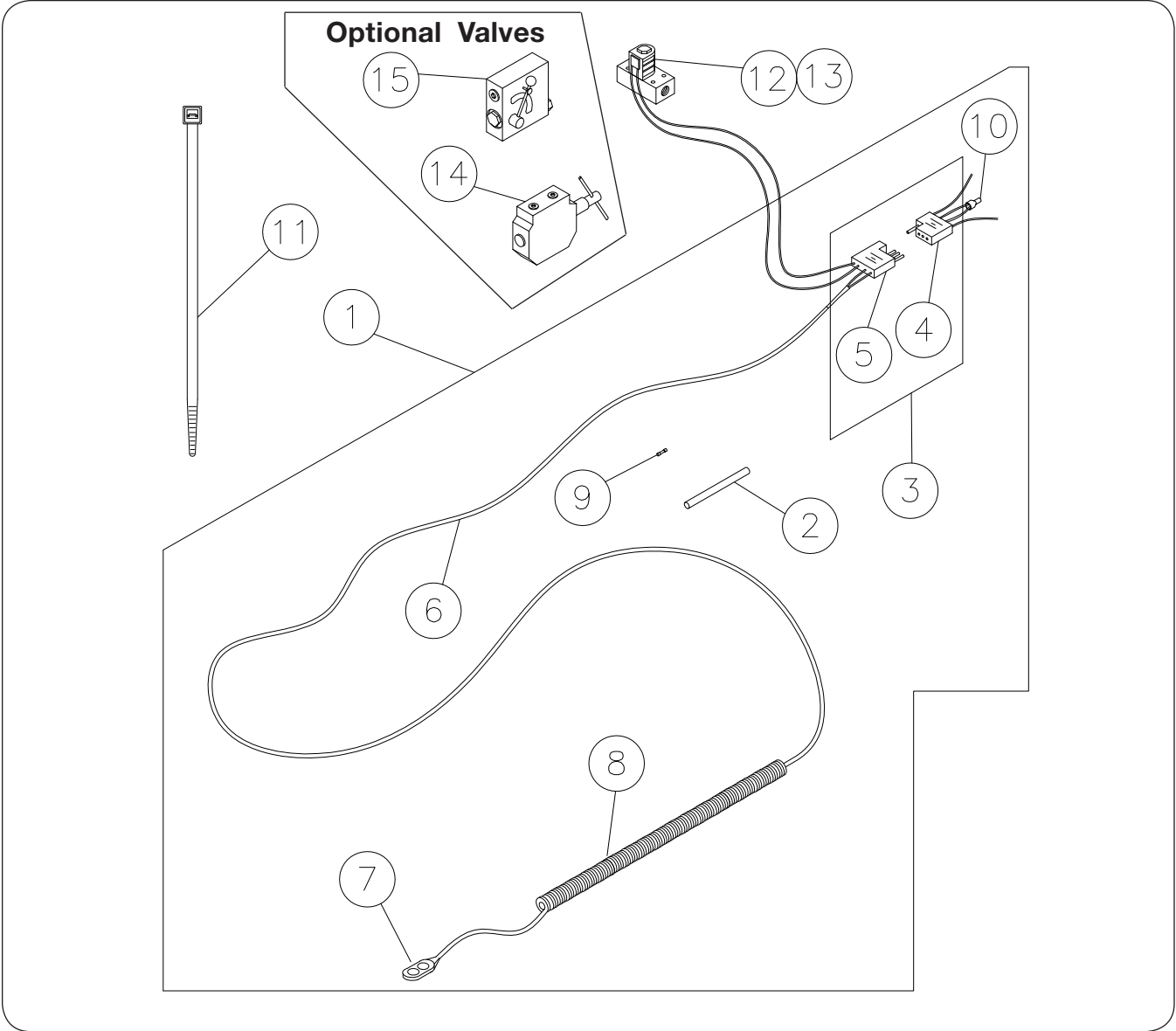



**Wiring Harness & Valves**

<b>ITEM</b>	<b>PART NO.</b>	<b>DESCRIPTION</b>
1	21108	Complete Harness Assembly
2	20208	Shrink Tubing 4" Lg.
3	91029	Polarized Connector Package
4	20209	Polarized Connector (Female)
5	20210	Polarized Connector (Male)
6	21117	Wire Cord 14 1/2 Ft. Lg.
7	92803	Switch
8	92933	Retractable Cord 48" Lg.
9	91023	Butt Splice Wire Connector
10	91022	Wire Nut
11	94038	Cable Tie 32" Lg.
12	95906	Control Valve Complete
13	95909	Solenoid/Cartridge Valve ONLY
14	91280	3-Way Selector Valve (Optional)
15	95323	Flow Control Valve (Optional)



***Unverferth***<sup>®</sup>  
***Manufacturing Company, Inc.***

[www.unverferth.com](http://www.unverferth.com)