



Bulk Seed Handling

**PLANTER TUBE-CONVEYOR**

Fits JD 1770/1775 CCS  
(MaxEmerge,  
Pro Series ExactEmerge)  
& JD DB CCS

Beginning With Serial Number A59530100 & Higher

Part No. 29986

## Foreword



This symbol identifies important safety messages. When you see it, read the message that follows and be alert to the possibility of personal injury.

Remember, safety instructions stated in this manual are for your protection. Read them carefully and follow them closely when working around or using this machine.

Read and study this manual completely before attempting to operate this implement. Take this manual to the field for handy reference when operating, adjusting, or servicing your machine.

When referenced, “Right-Hand” (RH) and “Left-Hand” (LH) side of the machine are determined by standing behind the machine and facing in the direction of travel.

## Product Information

When ordering parts or when requesting further information or assistance, always give the following information:

- Machine name
- Serial number

All products manufactured by Unverferth Mfg. Co., Inc. are warranted to be free from material and workmanship defects for one full year from time of consumer delivery. Your local dealer will gladly assist you with any warranty questions.

Please fill out and retain this portion for your records. The serial number plate is located on the conveyor tube, next to the discharge spout (Fig. 1).

Purchase Date \_\_\_\_\_ Model \_\_\_\_\_ Serial No. \_\_\_\_\_

Installed On Planter Make \_\_\_\_\_ Model Number \_\_\_\_\_

Dealer \_\_\_\_\_ City \_\_\_\_\_

Dealer Contact \_\_\_\_\_ Phone \_\_\_\_\_

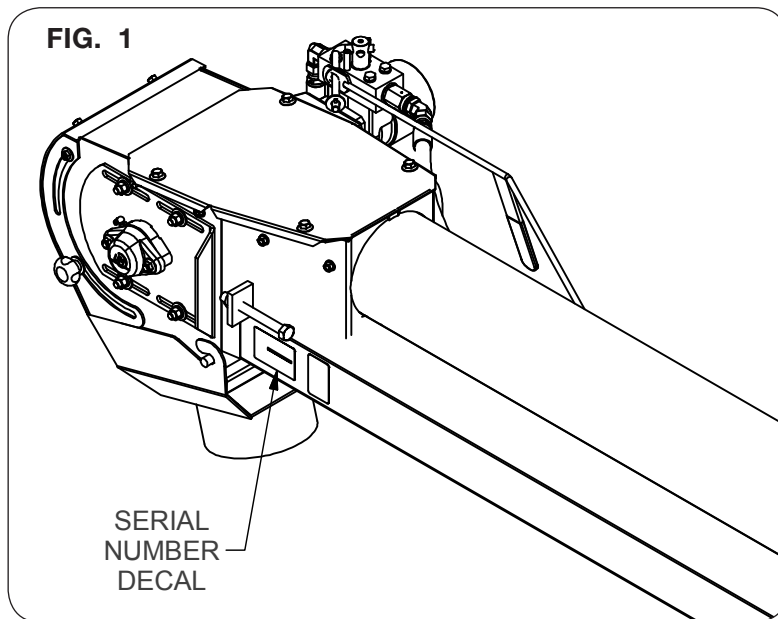

### IMPORTANT

*The information, specifications, and illustrations in the manual are on the basis of information available at the time it was written. Due to continuing improvements in the design and manufacture of Unverferth products, all specifications and information contained herein are subject to change without notice.*

**TABLE OF CONTENTS**

Foreword.....2  
Product Information.....3

**SECTION I**  
**Safety**

General Hazard Information.....1-2  
Safety Decals.....1-3  
Following Safety Instructions.....1-4  
Before Servicing.....1-4  
Before Operating.....1-4  
During Operation.....1-5  
Before Transporting.....1-5  
Pressurized Oil.....1-6  
Preparing for Emergencies.....1-7  
Wearing Protective Equipment.....1-7

**SECTION II**  
**Setup**

General.....2-2  
Preparing Planter.....2-4  
Ladder Bundle #24516 For JD 1770/1775/DB Planters with Pro-Series.....2-5  
Pivot Car/Sliding Rail.....2-7  
Extension, Horizontal, & Vertical Post  
For JD 1770/1775 & DB 30" Row Spacing Planters.....2-8  
Extension, Horizontal, & Vertical Post  
For JD 1770/1775 & DB 20/22" Row Spacing Planters.....2-12  
Extension, Horizontal, & Vertical Post  
For JD 1770/1775 & DB 15" Row Spacing Planters.....2-15  
Tube Conveyor.....2-19  
Hopper.....2-21  
Attaching The Conveyor.....2-25  
Telescopic Spout Assembly.....2-26  
Optional Hopper Lift Stand Bundle #26588B.....2-27  
Relocating SMV.....2-29  
Hydraulics.....2-31  
Rear View Layout.....2-33  
Reattach Light.....2-34  
Optional Hydraulic Flow Control Valve Kit #23669.....2-35  
Optional Anti-Reverse Check Valve Kit #23336.....2-37  
Optional Planter Fill-Conveyor Belt Stretcher  
For Replacement of Cleated Belts.....2-38  
Stretcher Assembled to Belt.....2-39

**TABLE OF CONTENTS**

**SECTION III**  
**Operation**

Preparing Planter .....3-2  
Operating Procedures.....3-2  
Transporting.....3-6  
Hydraulics .....3-7  
Clean-Out Doors .....3-8

**SECTION IV**  
**Maintenance**

Lubrication .....4-2  
    Conveyor Bearings.....4-2  
    Miscellaneous Lube Points .....4-2  
Storage/Maintenance .....4-2  
Hydraulic System.....4-3  
Conveyor Belt .....4-4  
    Belt Tension.....4-4  
    Belt Tracking.....4-5  
Belt Replacement .....4-7  
Troubleshooting .....4-8  
Torque Chart .....4-10  
Hydraulic Fittings.....4-10

**SECTION V**  
**Parts**

Idler End Components .....5-2  
Hopper Components .....5-4  
Mounting Brackets & Pivot Cart/Slide Rail Components  
    Pivot Car/Slide Rail Components .....5-6  
Extension, Horizontal, & Vertical Post For JD 1770/1775  
& DB 30" Row Spacing Planter.....5-8  
Extension, Horizontal, & Vertical Post For JD 1770/1775  
& DB 15" Row Spacing Planters.....5-9  
Discharge Spout Components .....5-12  
Telescopic Spout Components.....5-12  
Hydraulic Components .....5-14  
Optional Flow Control Valve Kit Components .....5-15  
Ladder Bundle .....5-16  
Conveyor Options .....5-17

**Notes**

# **SECTION I**

# **Safety**

General Hazard Information.....	1-2
Safety Decals.....	1-3
Following Safety Instructions .....	1-4
Before Servicing.....	1-4
Before Operating.....	1-4
During Operation.....	1-5
Before Transporting .....	1-5
Pressurized Oil.....	1-6
Preparing for Emergencies .....	1-7
Wearing Protective Equipment.....	1-7

## General Hazard Information

No accident-prevention program can be successful without the wholehearted cooperation of the person who is directly responsible for the operation of the equipment.

A large number of accidents can be prevented only by the operator anticipating the result before the accident is caused and doing something about it. No power-driven equipment, whether it be transportation or processing, whether it be on the highway, in the field, or in the industrial plant, can be safer than the person who is at the controls. If accidents are to be prevented--and they can be prevented--it will be done by the operators who accept the full measure of their responsibility.

It is true that the designer, the manufacturer, and the safety engineer can help; and they will help, but their combined efforts can be wiped out by a single careless act of the operator.

It is said that, "the best kind of a safety device is a careful operator." We, at Unverferth Mfg. Co., Inc. ask that you be that kind of operator.



**REMEMBER:**  
**THINK SAFETY**  
A CAREFUL OPERATOR IS THE  
BEST INSURANCE AGAINST AN  
ACCIDENT!

### SIGNAL WORDS

 **DANGER**

INDICATES AN EXTREMELY HAZARDOUS SITUATION OR ACTION THAT WILL RESULT IN SERIOUS INJURY OR DEATH.

---

 **WARNING**

INDICATES A HAZARDOUS SITUATION OR ACTION THAT COULD RESULT IN SERIOUS INJURY OR DEATH.

---

 **CAUTION**

INDICATES AN UNSAFE SITUATION OR ACTION THAT MAY RESULT IN PERSONAL INJURY.

---

**IMPORTANT**

*Is used for instruction on operating, adjusting, or servicing a machine.*



**Safety Decals**

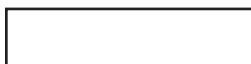
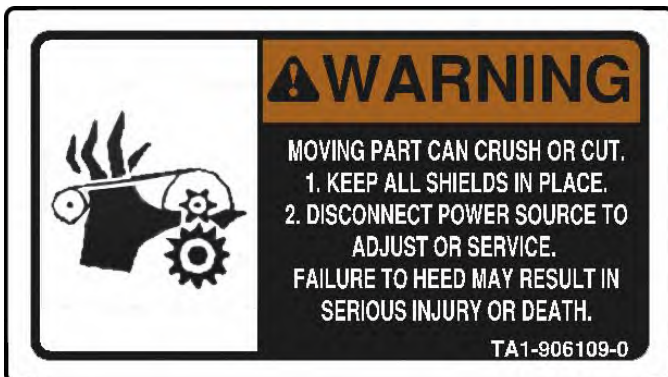

Part #9003125  
 Fluorescent Reflector

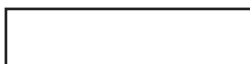

Part #9003126  
 Red Reflector



Part #9003127  
 Amber Reflector

## Following Safety Instructions

- Read and understand this operator's manual before operating.



- All machinery should be operated only by trained and authorized personnel.

- To prevent machine damage, use only attachments and service parts approved by the manufacturer.

- Always shut tractor engine off and remove key before servicing.



- Avoid personal attire such as loose fitting clothing, shoestrings, drawstrings, pants cuffs, long hair, etc., that may become entangled in moving parts.

- Do not allow anyone to ride on the implement. Make sure everyone is clear before operating machine or towing vehicle.



## Before Servicing

- Avoid working under an implement; however, if it becomes absolutely unavoidable, make sure the implement is safely blocked.
- Ensure that all applicable safety decals are installed and legible.



## Before Operating

- Always make certain everyone and everything is clear of the machine before beginning operation.
- Verify that all safety shields are in place and properly secured.
- Ensure that all applicable safety decals are installed and legible.

### During Operation

- Regulate speed to field conditions. Maintain complete control at all times.
- Never lubricate equipment when in operation.
- Keep away from overhead power lines. Electrical shock can cause serious injury or death.
- Use extreme care when operating close to ditches, fences, or on hillsides.
- Do not leave towing vehicle unattended with engine running.

### Before Transporting

- Install transport locks before transporting.

### Pressurized Oil

- Relieve the hydraulic system of all pressure before adjusting or servicing. See hydraulic power unit manual for procedure to relieve pressure.

---
- High-pressure fluids can penetrate the skin and cause serious injury or death. Use cardboard or wood to detect leaks in the hydraulic system. Seek medical treatment immediately if injured by high-pressure fluids.

---
- Hydraulic system must be purged of air before operating to prevent serious injury or death.

---
- Do not bend or strike high-pressure lines. Do not install bent or damaged tubes or hoses.

---
- Repair all oil leaks. Leaks can cause fires, personal injury, and environmental damage.

---
- Route hoses and lines carefully to prevent premature failure due to kinking and rubbing against other parts. Make sure that all clamps, guards and shields are installed correctly.

---
- Check hydraulic hoses and tubes carefully. Replace components as necessary if any of the following conditions are found:
  - o End fittings damaged, displaced, or leaking.
  - o Outer covering chafed/cut or wire reinforcing exposed.
  - o Outer covering ballooning locally.
  - o Evidence of kinking or crushing of the flexible part of a hose.

**Prepare for Emergencies**

- Keep a first aid kit and properly rated fire extinguisher nearby.



- Keep emergency numbers for fire, rescue, and poison control personnel near the phone.



**Wearing Protective Equipment**

- Wear clothing and personal protective equipment appropriate for the job.  
\_\_\_\_\_
- Wear steel-toed shoes when operating.  
\_\_\_\_\_
- Wear hearing protection when exposed to loud noises.  
\_\_\_\_\_
- Do not wear additional hearing impairing devices such as radio headphones, etc



**Notes**

## **SECTION II**

# **Setup**

General.....	2-2
Preparing Planter.....	2-4
Ladder Bundle #24516 For JD 1770/1775/DB Planters with Pro-Series.....	2-5
Pivot Car/Sliding Rail.....	2-7
Extension, Horizontal, & Vertical Post For JD 1770/1775 & DB 30" Row Spacing Planters .....	2-8
Extension, Horizontal, & Vertical Post For JD 1770/1775 & DB 20/22" Row Spacing Planters .....	2-12
Extension, Horizontal, & Vertical Post For JD 1770/1775 & DB 15" Row Spacing Planters .....	2-15
Tube Conveyor.....	2-19
Hopper .....	2-21
Attaching The Conveyor .....	2-25
Telescopic Spout Assembly.....	2-26
Optional Hopper Lift Stand Bundle #26588B .....	2-27
Relocating SMV .....	2-29
Hydraulics .....	2-31
Rear View Layout.....	2-33
Reattach Light.....	2-34
Optional Hydraulic Flow Control Valve Kit #23669.....	2-35
Optional Anti-Reverse Check Valve Kit #23336.....	2-37
Optional Planter Fill-Conveyor Belt Stretcher For Replacement of Cleated Belts.....	2-38
Stretcher Assembled to Belt.....	2-39

## General

This section contains all of the instructions required for the complete assembly of the CONVEYOR to your planter.

For your safety, and the safety of others, use proper tools and equipment and always use safe working procedures. Refer to these instructions before starting any work on your machine.

### IMPORTANT

- *The procedures for assembling this unit are intended for two or more people.*
- *Planters which utilize the ExactEmerge Planting System may have two battery access doors located on the platform between the two seed tanks. The conveyor mounts over these doors and will prevent access to the battery compartments.*

For ease of assembly, install all hardware loosely until assembly is complete and then tighten according to "Torque Chart".

Place planter on a solid, level surface with sufficient clear space to unfold the wings of the planter. Unfold wings, lower unit to the ground, block from moving, set the tractor brakes, shut-off the engine, and remove the ignition key.

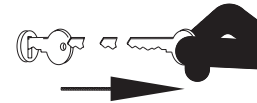

You should receive the following bundles:

**PARTS BOX**  
**PART #25270**

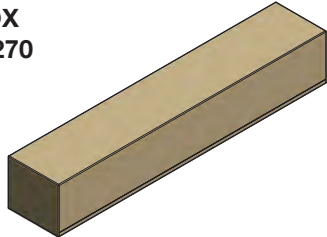

**CONVEYOR ASSEMBLY 6x18**  
**PART #25150B**



**LADDER BUNDLE**  
**PART #24516**

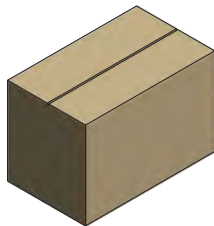

**FLOW CONTROL VALVE BUNDLE**  
**PART #23669**

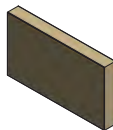

**VERTICAL POST WELDMENT**  
**PART #24338B**

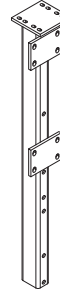

**HAND RAIL WELDMENT**  
**PART #23730G**

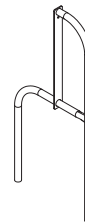

**HOPPER BUNDLE**  
**PART #27717B**



**TELESCOPIC SPOUT**  
**PART #27629**

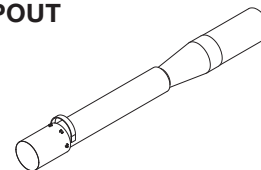



## General (continued)

### **⚠ WARNING**

- **KNOW AND UNDERSTAND SAFETY RULES BEFORE ASSEMBLING, OPERATING OR SERVICING THIS MACHINE. REVIEW "SAFETY" SECTION IN THIS MANUAL, TRACTOR AND PLANTER OPERATOR MANUALS IF NECESSARY.**
- **TIPPING OR MOVEMENT OF THE MACHINE CAN CAUSE SERIOUS INJURY OR DEATH. BE SURE THE MACHINE IS SECURELY BLOCKED.**
- **HIGH-PRESSURE FLUIDS CAN PENETRATE THE SKIN AND CAUSE SERIOUS INJURY OR DEATH. USE CARDBOARD OR WOOD TO DETECT LEAKS IN THE HYDRAULIC SYSTEM. SEEK MEDICAL TREATMENT IMMEDIATELY IF INJURED BY HIGH-PRESSURE FLUIDS.**
- **MOVING PARTS CAN CRUSH AND CUT. KEEP AWAY FROM MOVING PARTS.**
- **KEEP HANDS CLEAR OF PINCH POINT AREAS.**
- **EYE PROTECTION AND OTHER APPROPRIATE PERSONAL PROTECTIVE EQUIPMENT MUST BE WORN WHILE SERVICING THE IMPLEMENT.**
- **FALLING OBJECTS CAN CAUSE SERIOUS INJURY OR DEATH. DO NOT WORK UNDER THE MACHINE AT ANY TIME WHILE BEING HOISTED. BE SURE ALL LIFTING DEVICES AND SUPPORTS ARE RATED FOR THE LOADS BEING HOISTED. THESE ASSEMBLY INSTRUCTIONS WILL REQUIRE SAFE LIFTING DEVICES UP TO 500 LBS. SPECIFIC LOAD RATINGS FOR INDIVIDUAL LOADS WILL BE GIVEN AT THE APPROPRIATE TIME IN THE INSTRUCTIONS.**

### **IMPORTANT**

- *Attach the reflectors to the tube conveyor hopper end as shown below.*

**FIG. 2-1**

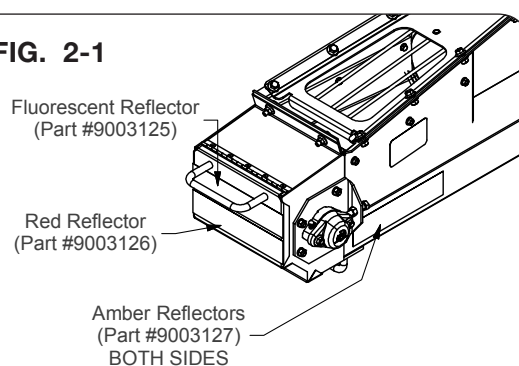

## Preparing Planter

1. Lower planter to the ground.

**NOTE:** Park the unit on a firm, level surface. Block the tires on the machine to keep it from moving. Set the tractor's parking brake, shut-off the engine and remove the ignition key.

2. Remove the left-side platform railing at the rear of the planter by removing the four bolts and nuts.

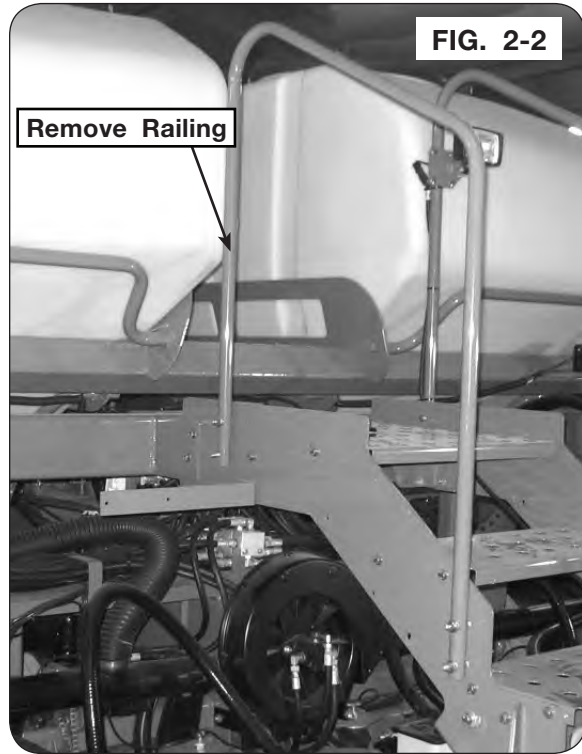

3. Remove the light and wire harness and then loosen the bolts which secure it. Remove the railing and install the provided railing in its place. Locate the notch to the left side as shown and leave hardware loose, the railing will be adjusted once the conveyor is installed. Do not reattach the light and harness. This will be completed later.
4. Remove the bolt and reposition as shown to the right.

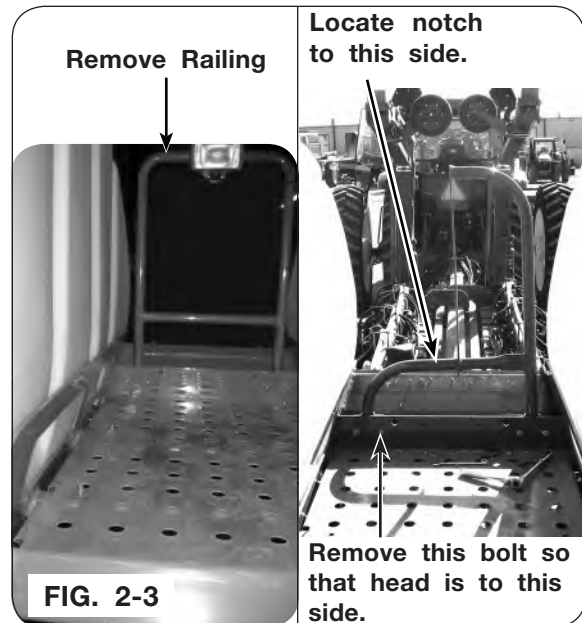

## Ladder Bundle #24516

For JD 1770/1775/DB Planters with Pro-Series

### IMPORTANT

- Retain hardware, it will be re-used to attach new steps.

1. Dismantle steps from side plates.
  - a. First remove the original step from planter by removing indicated bolts.

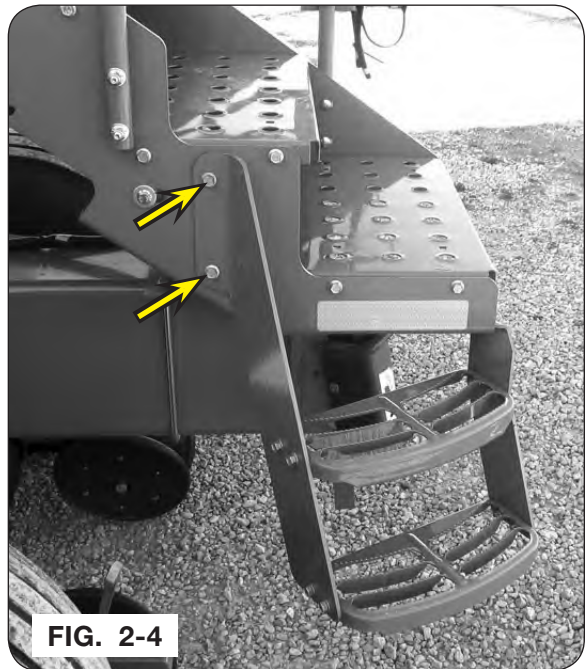

- b. Dismantle each step from end plates, these steps will be re-used.
- c. Remove the four bolts securing the lower platform (one side at a time) and install new step mounting side plates. Tighten hardware securely.



### Ladder Bundle #24516

#### For JD 1770/1775/DB Planters with Pro-Series (continued)

- d. Loosely install vertical side plates using 1/2" bolt and locknuts provided, per side. Install original steps into side plate brackets using original hardware. Once steps are installed, secure all step hardware.

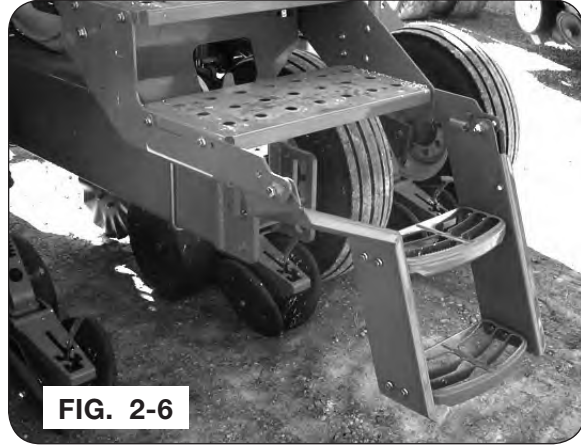

FIG. 2-6

Remove lower platform hardware (one side at a time) and install step mounting side plates.

- e. Install gas spring ball joints. First, assemble ball joints into appropriate holes on right side of steps. Secure using 5/16" locknuts.

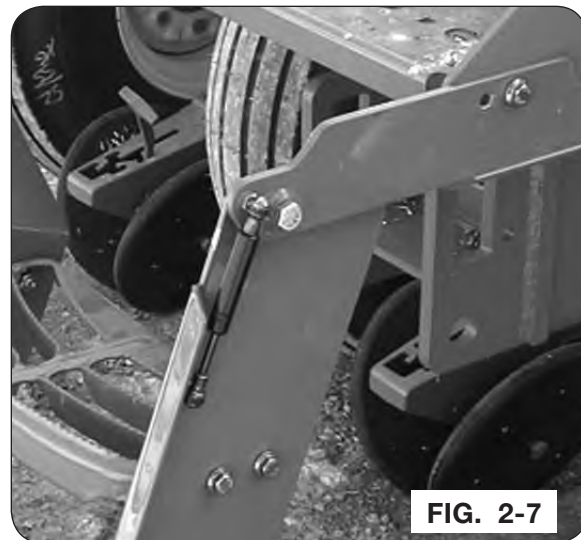

FIG. 2-7

- f. Install gas spring. First, slide retaining sleeve down using small flat screw-driver. Do not remove retainer, it should just slide down enough to assemble over ball joint. Secure one side on ball joint and then use adjustable pliers to push in on gas spring to assemble to opposite ball joint. Be sure ball joint retainers are closed after assembly.

## Pivot Car/Sliding Rail

1. On the top platform, remove the three bolts on the left-hand side securing the platform to the planter as shown.

**NOTE:** Outer two bolts need to be replaced with 1/4"x3/4" HCS bolts (9390-003) and flange nuts (97189).

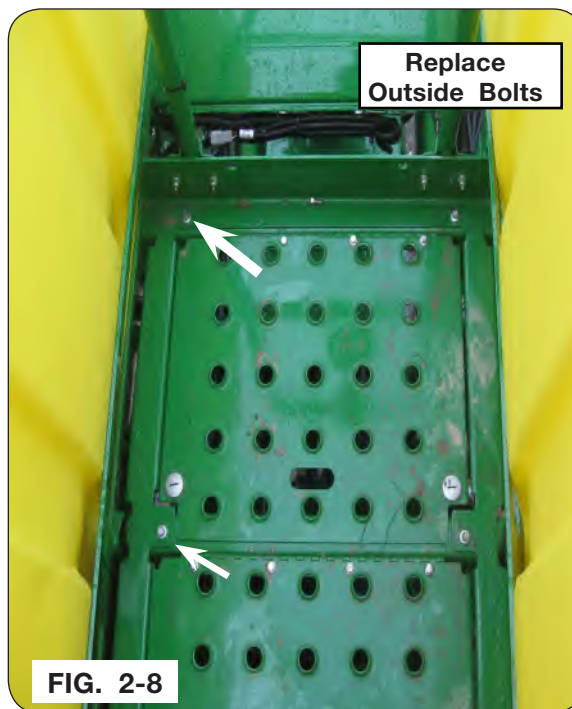

2. Remove parts once rail assy. is installed and secured on planter deck.
3. Align the three holes in the rail with the three holes on the platform. Secure the rail by installing three longer metric M8-1.25Px30 capscrews (94917-073) and 3/8" flat washers (9405-074), and on the bottom-side of the platform use M8-1.25P hex nuts (97692).



**NOTE:** Beginning with the 2015 model year, JD Planters have 2 access doors on the planter platform providing access to batteries for the ExactEmerge Row Unit system. ExactEmerge customers will have limited access to the batteries unless they modify/cut the doors. Contact Unverferth Mfg. for additional planter fill options.



**Pivot Car Support Brackets  
For JD 1770/1775 & DB 30" Row Spacing Planters**

1. Install the rail support extension post (24413B) and secure using four 5/16"-18UNC x 1" cap-screws (9390-030) and 5/16"-18UNC lock nuts (9807).

**NOTE:** Tubes may need to be cut to length to fit specific planters

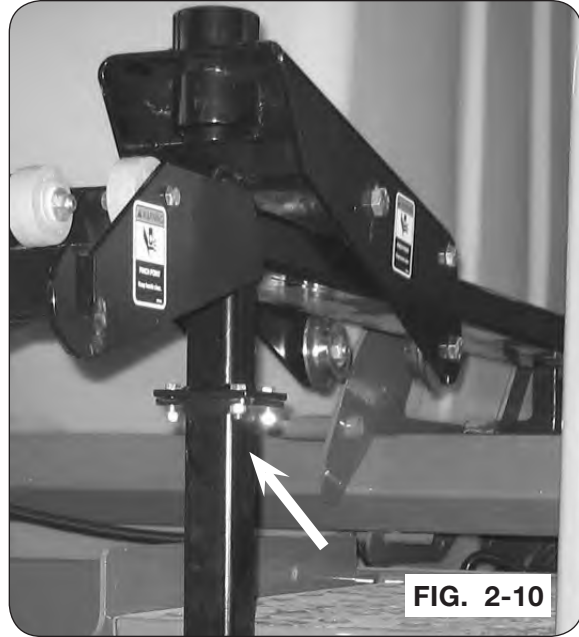

2. The horizontal post (24340B) is the shorter 2"x3" tube with a plate on the end. Locate the post between the steps and secure using clamping plate (23751B), four 1/2"-13UNC x 3-1/2" capscrews (9390-109), 1/2" flat washers (9405-086), and 1/2"-13UNC lock nuts (9800).

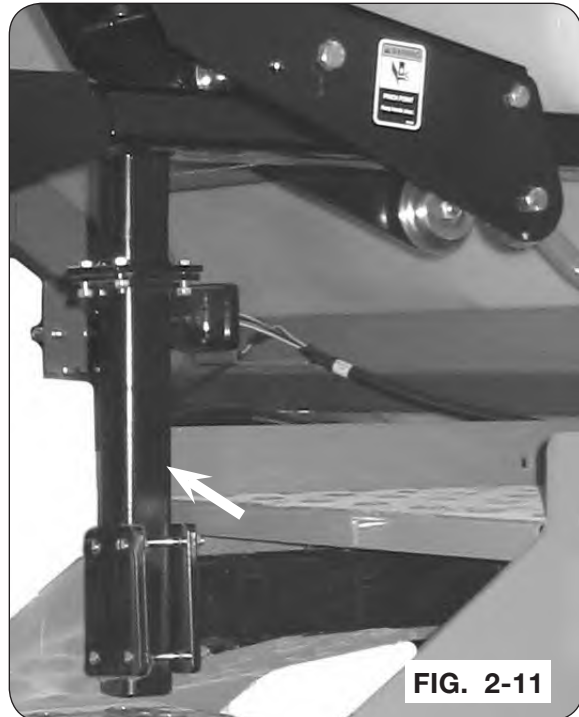

**Pivot Car Support Brackets  
For JD 1770/1775 & DB 30" Row Spacing Planters**

3. Attach the vertical post (24338B - the longer 2x3" tube with plate on end) using clamping plate (23751B), four 1/2"-13UNC x 4-1/2" capscrews (9390-112), flat washers 1/2" (9405-086), and 1 1/2"-13UNC lock nuts (9800). Position tube under platform. The plates on the vertical post should be facing to the right.

**NOTE:** Vertical post may interfere with planter steps. If this occurs, cut bottom of vertical post to shorten the length to avoid interference with planter steps.

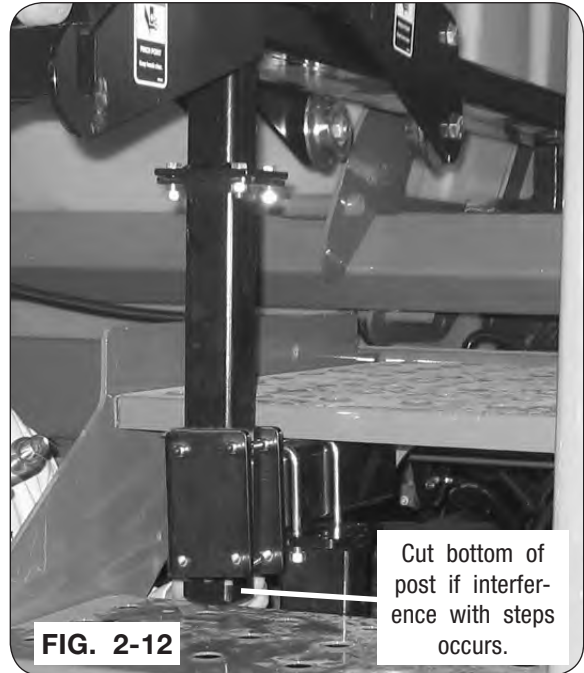

**FIG. 2-12**

VERTICAL POST	
HOLE	MOUNTING REFERENCE
A	JD1770/1775 (Pro-Series/8x12 Hitch Tube)
B	JD1770/1775 (Max-Emerge/8x12 Hitch Tube)
C	DB (Pro-Series)
D	JD1770/1775 (Pro-Series/8x16 Hitch Tube)

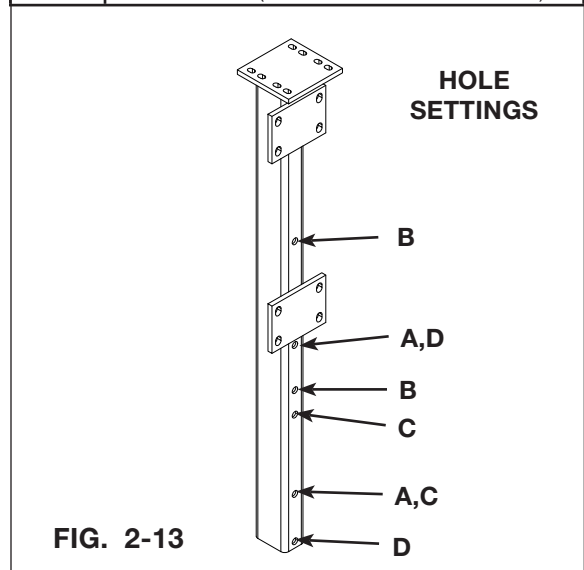

**FIG. 2-13**

**Pivot Car Support Brackets  
For JD 1770/1775 & DB 30" Row Spacing Planters**

4. Secure the vertical post to the planter as follows:

**JD 1770/1775 CCS PLANTER**

Use one strap/bar (24341B), two cap-screws 1/2-13UNC x 13 (9390-901012) and locknuts 1/2-13UNC (9800).



**JD DB CCS PLANTER**

Use one strap/bar (24409B), two capscrews 1/2-13UNC x 9 (9390-435) and locknuts 1/2-13UNC (9800).

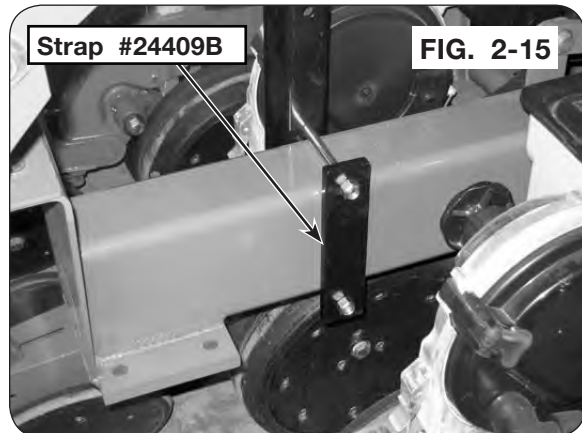



### Pivot Car Support Brackets For JD 1770/1775 & DB 30" Row Spacing Planters

5. Tighten all post hardware according to "Torque Chart".
6. A support screw needs to be installed to tie the support posts to the platform. On the step, just below the horizontal post (24340B), a 5/16" hole must be drilled through the lip of the step and into the vertical post (24338B). Secure using screw/self-drilling 3/8"-16UNC x 1" (96972) as shown.

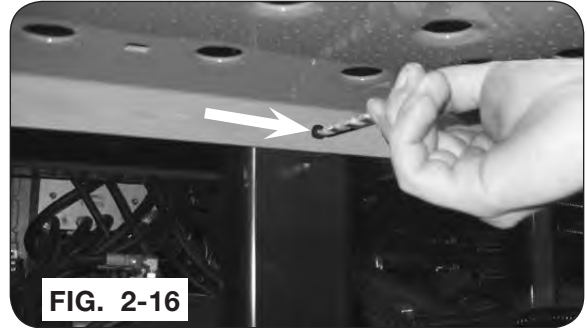

**Pivot Car Support Brackets  
For JD 1770/1775 & DB 20/22" Row Spacing Planters**

1. Install the rail support extension post (24413B) and secure using four 5/16"-18UNC x 1" cap-screws (9390-030) and 5/16"-18UNC lock nuts (9807).

**NOTE:** Loosely install all hardware until all components of the support arm are installed.

**IMPORTANT**

- *Not all planters assemble the same and it may be necessary to modify the components provided with this mounting to fit properly.*



2. Locate one of the shorter 2" x 3" posts with a single plate on the end (24340B) and mount it to the rail support installed in the previous step. Position the post so that it is under the step facing towards the front of the planter. Secure using a single plate (23751B), four 1/2"-13UNC x 3-1/2" capscrews (9390-109), eight flat washers (9405-086) and four lock nuts (9800).

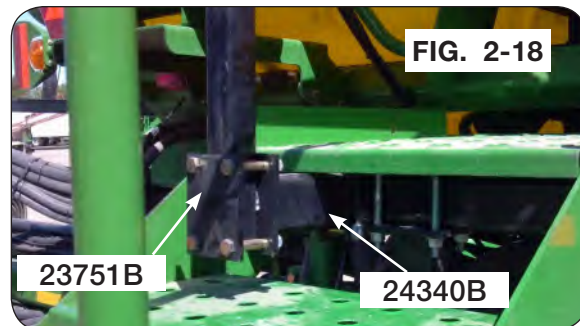

**Pivot Car Support Brackets  
For JD 1770/1775 & DB 20/22" Row Spacing Planters (continued)**

3. Assemble the lower vertical post (2000014B) and the longer vertical post (28442B) to each other using four 1/2"-13UNC x 1-1/2" bolts (9390-101), eight washers (9405-086) and four lock nuts (9800). (FIG. 2-19A & FIG. 2-19B)

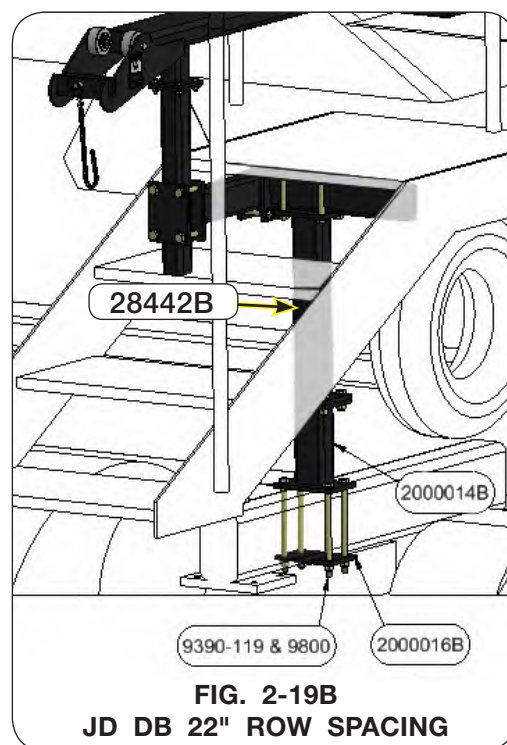
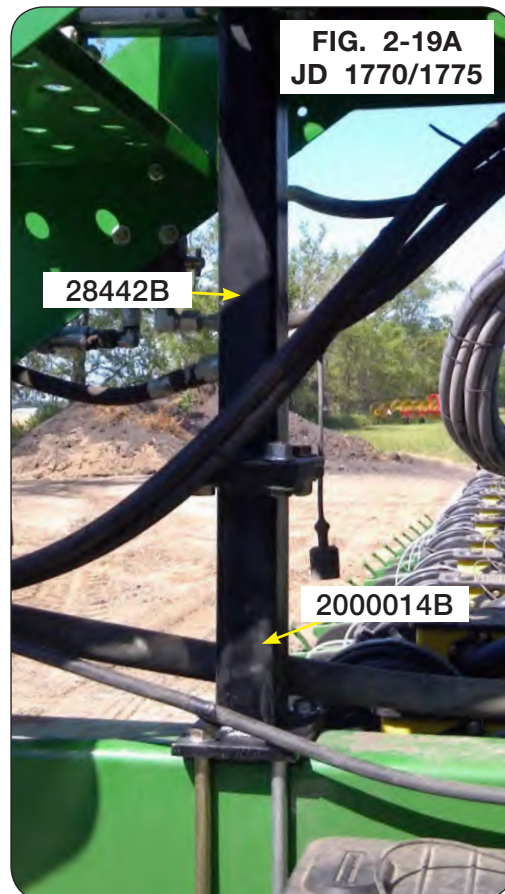

**Pivot Car Support Brackets  
For JD 1770/1775 & DB 20/22" Row Spacing Planters (continued)**

4. Position the tube assembly from step 3 onto the planter center tube and secure using a plate (2000016B), four 1/2"-13UNC x 8" capscrews (9390-119), eight flat washers (9405-086) and four lock nuts (9800) as shown in FIG. 2-20.

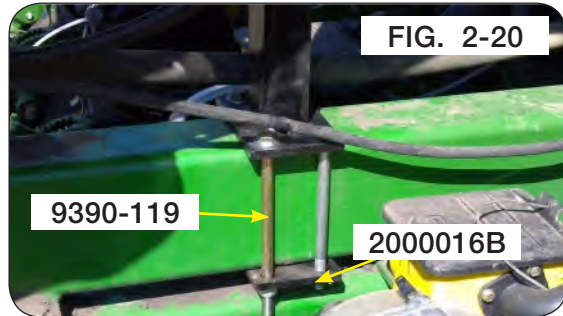

5. Mount the second 2" x 3" tube (24340B) on top of the vertical post assembly as shown. Secure using a plate (23751B), four 1/2"-13UNC x 4-1/2" capscrews (9390-112), eight flat washers (9405-086) and four lock nuts (9800).

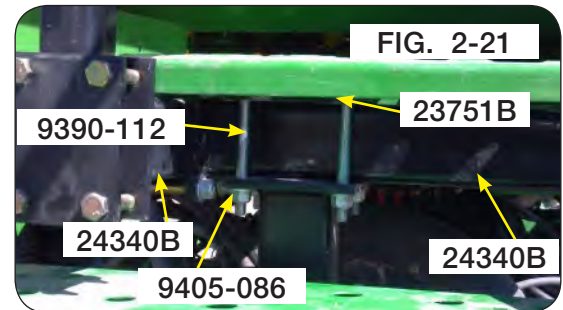

6. Make the final tube connection by adjoining the second 2" x 3" tube positioned in step 2. Secure using a plate (23751B), four 1/2"-13UNC x 3-1/2" capscrews (9390-109), eight flat washers (9405-086) and four lock nuts (9800). (FIG. 2-21)

7. Position all tubes so that they do not rub the planter and tighten all hardware securely.

## Pivot Car Support Brackets For JD 1770/1775 & DB 15" Row Spacing Planters (Prior to 2016)

1. Install the rail support extension post (24413B) and secure using four 5/16"-18UNC x 1" cap-screws (9390-030) and 5/16"-18UNC lock nuts (9807).

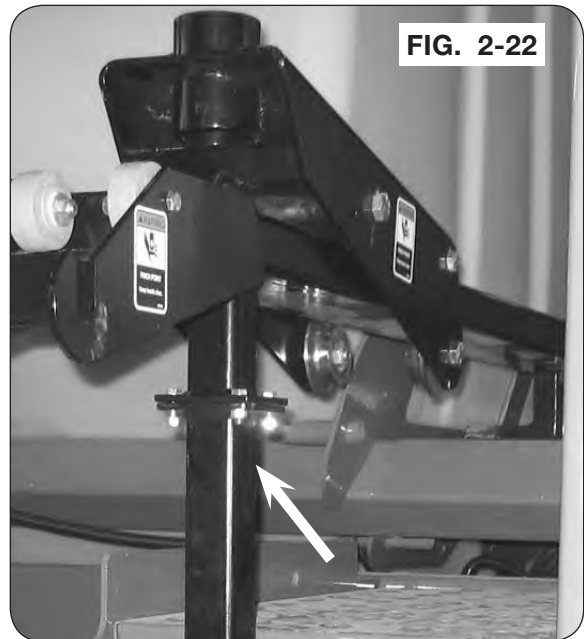

2. The horizontal post (24340B) is the shorter 2"x3" tube with a plate on the end. Locate the post between the steps and secure using two 3/8"-16UNC x 3" U-bolts (900077), 3/8" flat washers (9405-074), and 3/8"-16UNC lock nuts (9928). Install U-bolts on furthest set of holes on left.





## Pivot Car Support Brackets

For JD 1770/1775 & DB 15" Row Spacing Planters (Prior to 2016)

3. Attach the vertical post (24338B - the longer 2x3" tube with plate on end) using 3/8"-16UNC x 4" U-bolts (900076), 3/8" flat washers (9405-074), and 3/8"-16UNC lock nuts (9928). Position tube under platform and slide the U-bolts over the horizontal tube. The gusset on the vertical post should be facing to the left and should come in contact with the frame tube on the planter.

**NOTE:** Vertical post may interfere with planter steps. If this occurs, cut bottom of vertical post to shorten the length to avoid interference with planter steps.

4. Tighten all post hardware according to "Torque Chart".

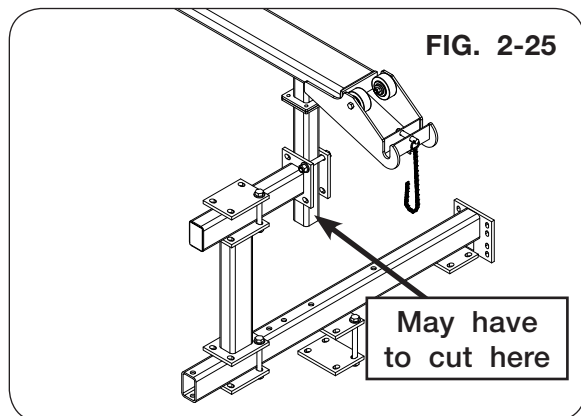

## Pivot Car Support Brackets - For JD DB60-24 Row Split 15" Row Spacing Planters (Produced 2016 & After)

1. Install the rail support extension post (24413B) and secure using four 5/16"-18UNC x 1" cap-screws (9390-030) and 5/16"-18UNC lock nuts (9807).

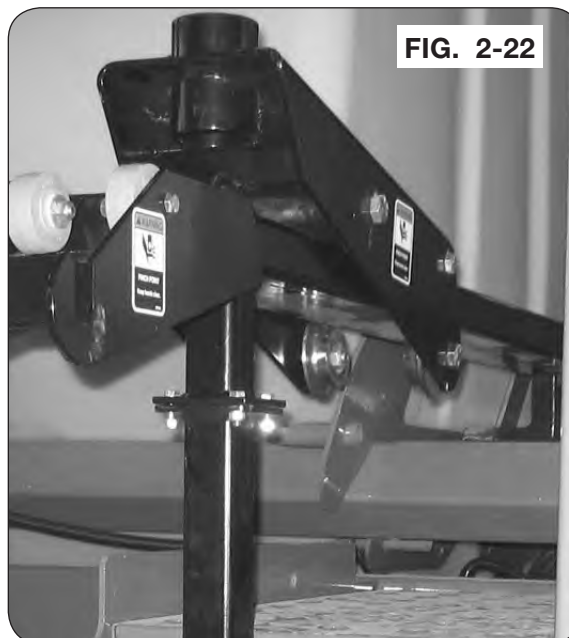

2. The horizontal tube weldment (2000014B) is the shorter 2"x3" tube with plates on the end. Locate the post between the steps and secure using a plate (23751B), four 1/2"-13UNC x 3 1/2" capscrews (9390-109), eight 1/2" SAE flat washer (9405-086), and four 1/2"-13UNC lock nuts (9800).

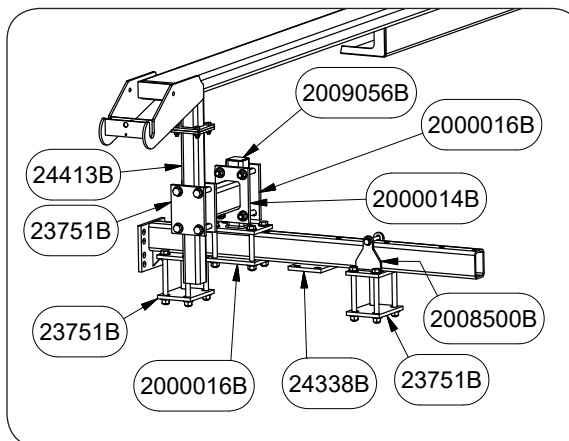

3. Attach the vertical 2"x2" tube weldment (2009056B - tube with plate on end) using plate (2000016B), four 1/2"-13UNC x 3 1/2" capscrews (9390-109), eight 1/2" SAE flat washer (9405-086), and four 1/2"-13UNC locknuts (9800).

4. Secure the vertical 2"x2" tube weldment (2009056B - tube with plate on end) to the horizontal tube weldment with mounting plates (24338B) with plate (2000016B), four 1/2"-13UNC x 4 1/2" capscrews (9390-112), eight 1/2" SAE flat washer (9405-086), and four 1/2"-13UNC locknuts (9800).



**Pivot Car Support Brackets - For JD DB60-24 Row Split  
15" Row Spacing Planters (Produced 2016 & After) (Continued)**

5. Attach the left-hand side of the horizontal tube weldment with mounting plates (24338B) to the planter with plate (23751B), four 1/2"-13UNC x 5 1/2" capscrews (9390-114), eight 1/2" SAE flat washer (9405-086), and four 1/2"-13UNC locknuts (9800).

6. Loosely secure the bracket weldment (2008500B) to the right-hand side of the horizontal tube weldment (24338B) with a 3/8"-16UNC x 3 1/4" capscrew, two 3/8" SAE flat washers (9405-074), and a 3/8"-16UNC locknut (9928).

7. Secure the bracket weldment (2008500B) to the planter with plate (23751B), four 1/2"-13UNC x 5 1/2" capscrews (9390-114), eight 1/2" SAE flat washer (9405-086), and four 1/2"-13UNC locknuts (9800).

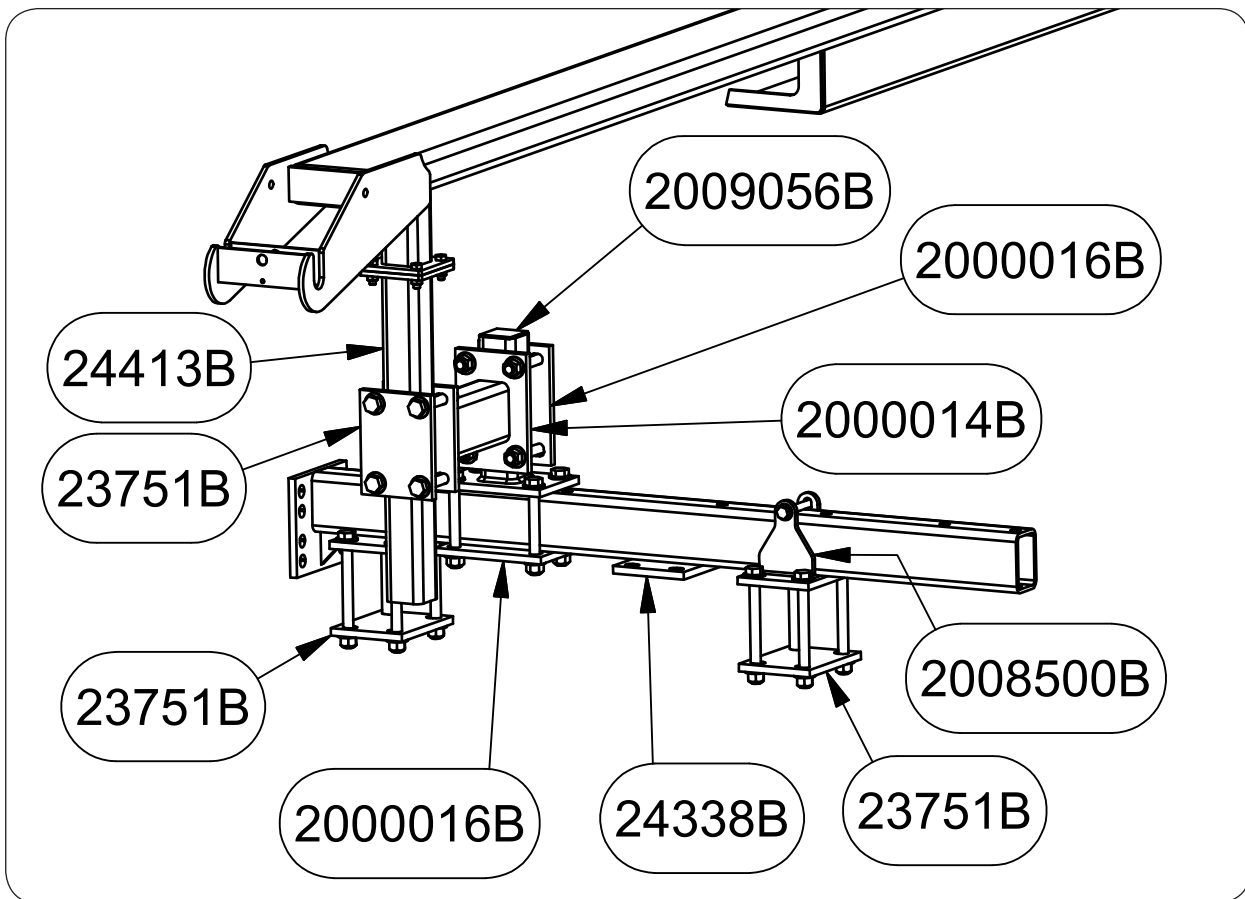
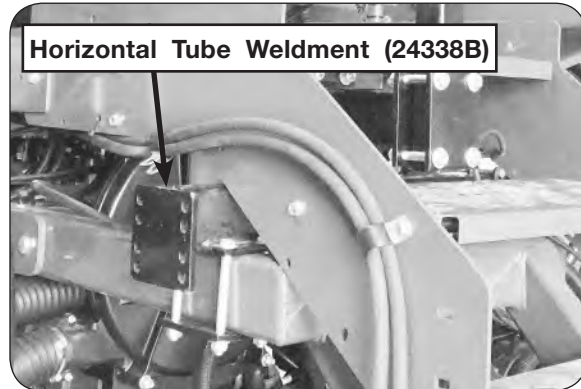

**NOTE:** Tube weldment (24413B) may interfere with planter steps. If this occurs, cut bottom of vertical post to shorten the length to avoid interference with planter steps.

8. Tighten all post hardware according to "Torque Chart".



## Tube Conveyor

1. Raise tube conveyor using a safe lifting device rated for 500 lbs. min.
2. Place tube conveyor on properly rated jack stands.
3. Insert tube/bushing (25307) into pivot weldment (25160B). Attach the pivot weldment and tube/bushing to the channel weldment (26564B) using 3/4"-10UNC x 9" capscrew (9390-449) and 3/4"-10UNC lock nut (96732) as shown in FIG. 2-27.
4. Attach the transport mount weldments (25155B) to tube conveyor in the standard position using 3/8"-16UNC x 1" screw/large flange (91262) as shown in Fig. 2-28.

### IMPORTANT

- Planters which have the optional fertilizer tanks will have to position the conveyor transport plates as shown in FIG. 2-28 and will increase the overall length when the conveyor is in the transport position by approximately 24".

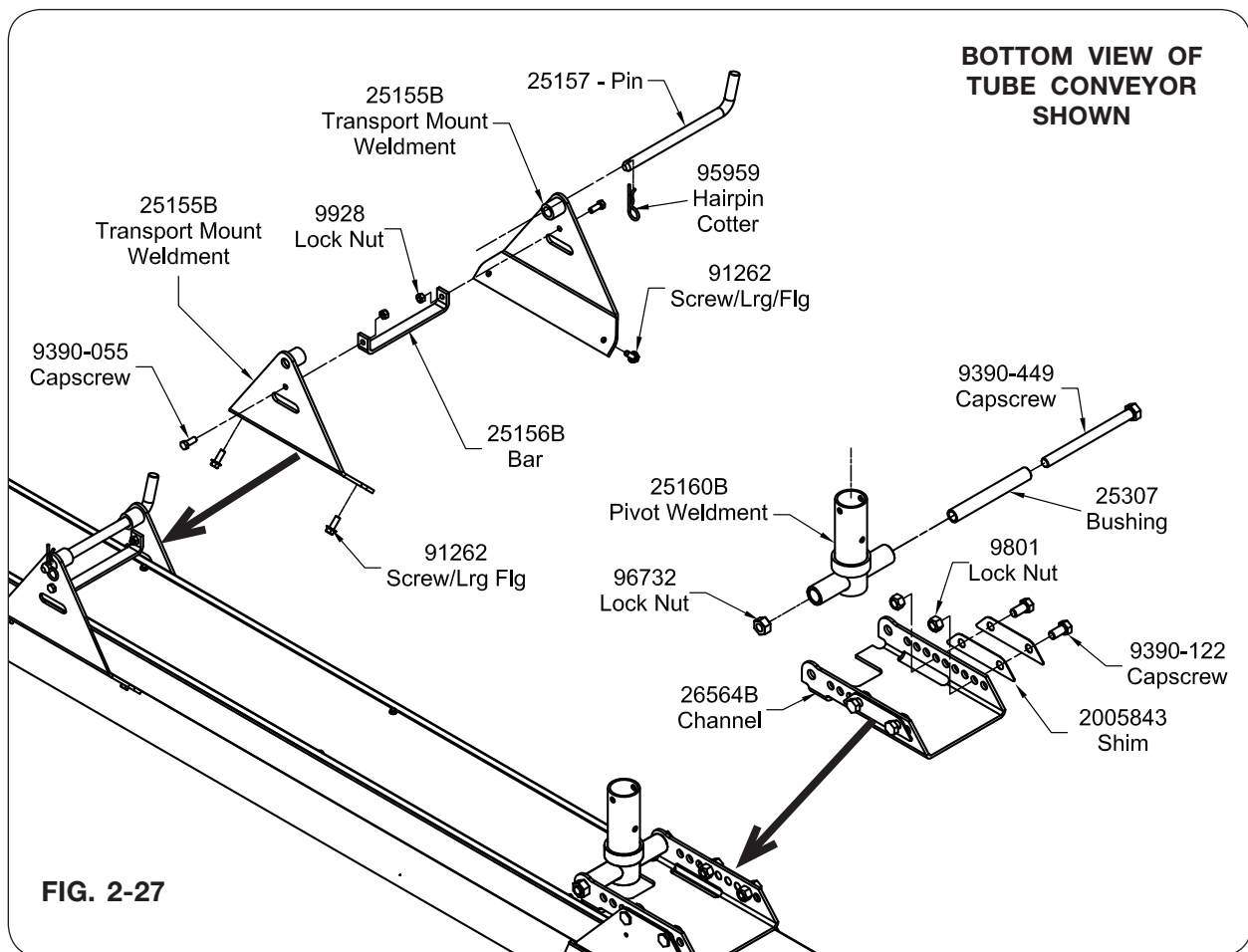

## Tube Conveyor (continued)

- Using 3/8"-16UNC x 1" capscrews (9390-055) and 3/8"-16UNC lock nuts (9928) attach the formed bar (25156B) (Fig. 2-27).

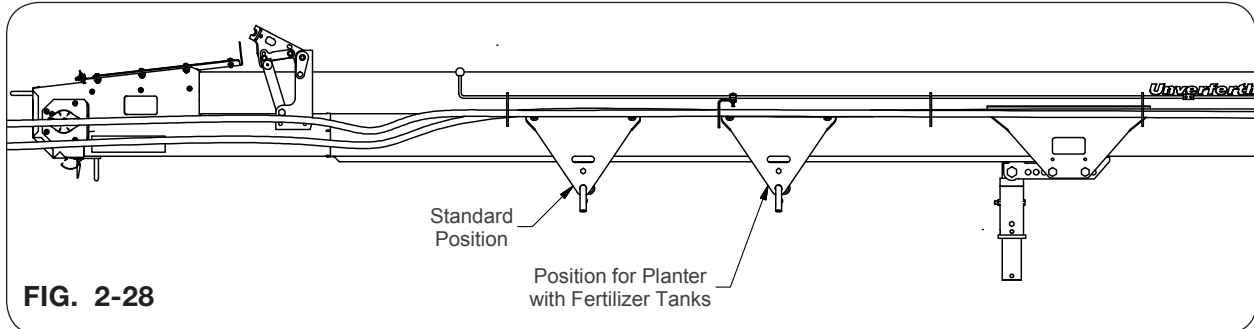

- Insert the formed pin (25157) through the transport mount weldments (25155B) and retain into position using hairpin cotter (95959) (Fig. 2-27).

## Hopper

1. Attach the pivot weldment (24554B) to the tube conveyor using pin weldment (24578), 3/8"-16UNC x 1" capscrew (9390-055), and 3/8"-16UNC lock nut (9928) (FIG. 2-29).
2. Attach the shim plate (25434B) to the pivot weldment (24554B) using 5/16"-18UNC x 1" screws/small flange (901044) and 5/16"-18UNC hex nuts (91257) (FIG. 2-29).
3. Push the grips (92928) onto the ends of the handle weldment (24576B). Attach the handle weldment (24576B) to the tube conveyor using 1/2"-13UNC x 1-1/2" capscrews (9390-101), bushings (24550), flat washers (9405-088) and 1/2"-13UNC lock nuts (9800) (FIG. 2-29).

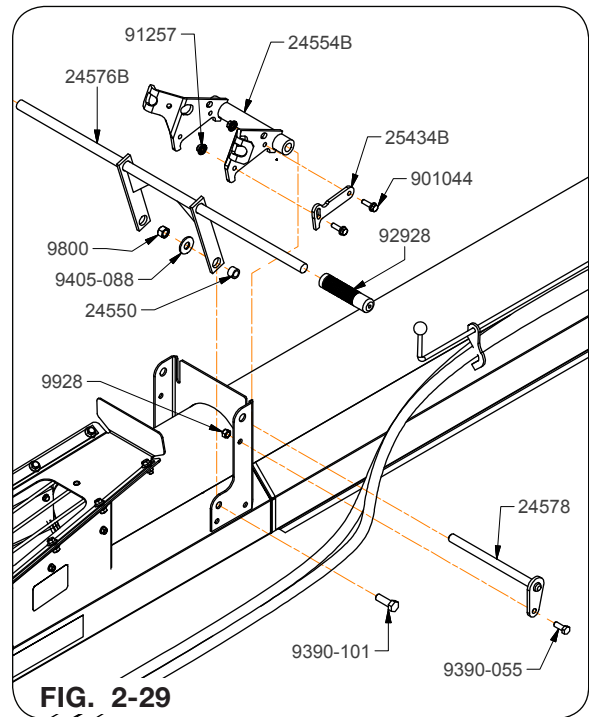

4. Spray lubricant inside the vinyl before installation. Insert the formed tube (26918B) into the vinyl hopper (902421) as shown in FIG. 2-30. Attach the formed tube (26918B) ends to the pivot weldment (24554B) using 5/16"-18UNC x 1 1/2" capscrews (9390-032) and 5/16"-18UNC lock nuts (9807).

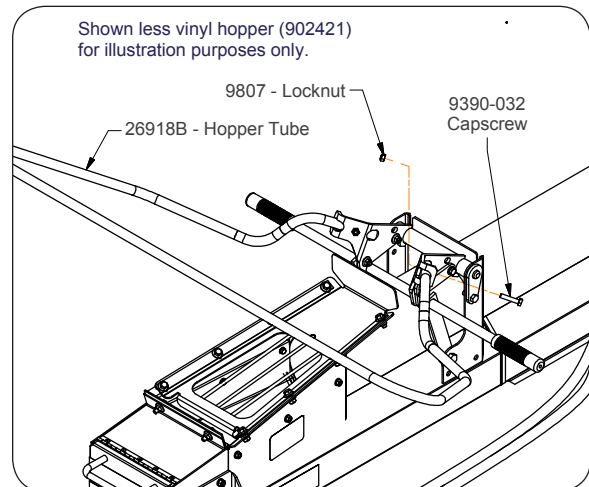
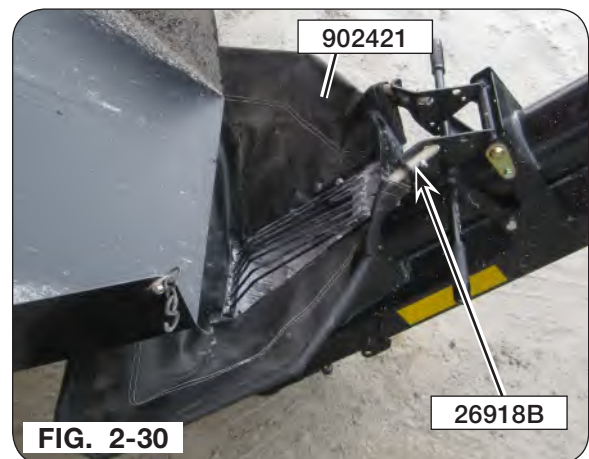

**Hopper (continued)**

5. Remove the 5/16"-18UNC hex nuts (91257), 5/16"-18UNC x 3/4" screws/large flange (91256), straps (24620B), and grate (28400B). Also remove the 5/16"-18UNC hex nuts (91257), capscrews (9390-030), strap (28486B), brush holder (24964) with nylon brush (901111), and seal (26865). See FIG. 2-31.

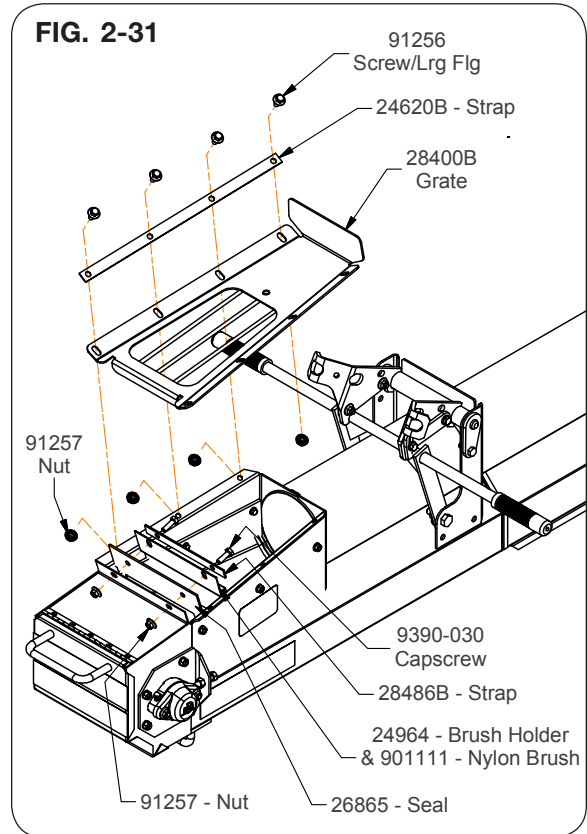

**Hopper (continued)**

6. Attach the vinyl hopper (902421) to the bottom of the tube conveyor with the previously removed parts (capscrews - 9390-030; strap - 28486B; brush holder - 24964 & nylon brush - 901111; seal - 26865; and nuts - 91257) and two poly strips (24986) as shown in FIG. 2-32 & FIG. 2-33.

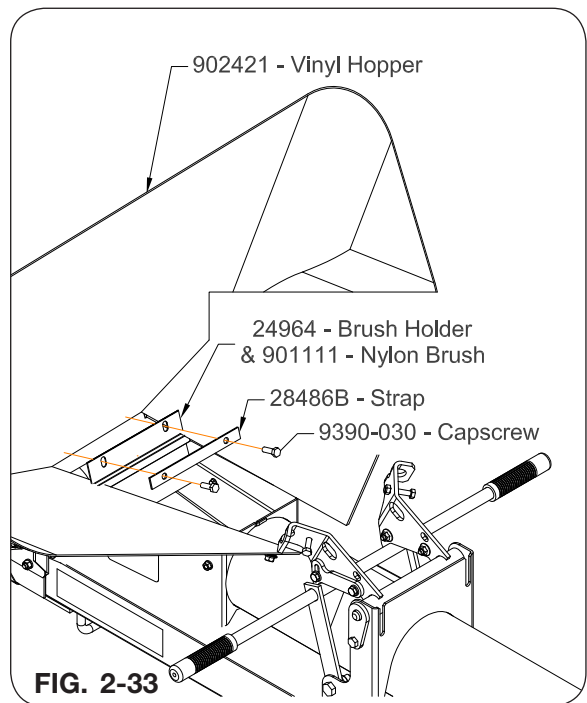
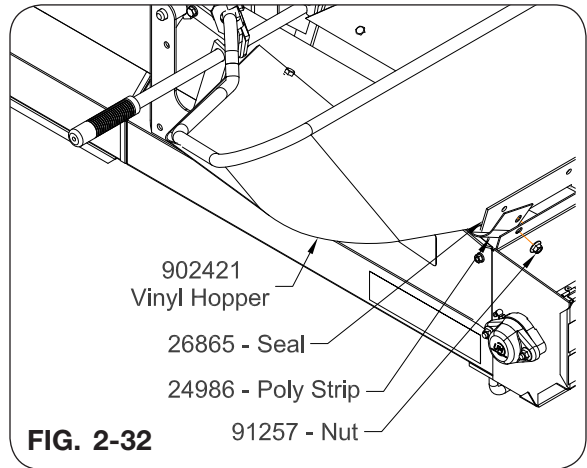

## Hopper (continued)

7. Attach the sides of the vinyl hopper to the tube conveyor with the previously removed parts (screws/lrg fig - 91256; straps - 24620B; grate - 28400B; and nuts - 91257) as shown in FIG. 2-34.

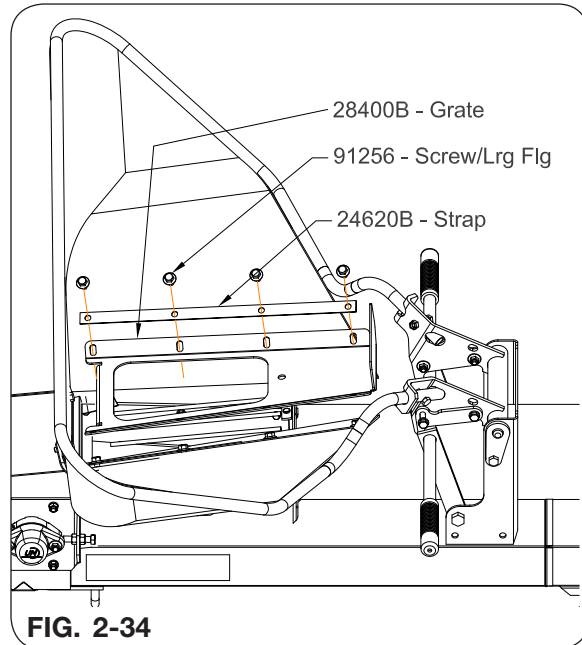

8. Secure the hopper lid/cover with bungee cord (27715) to the conveyor (FIG. 2-35).

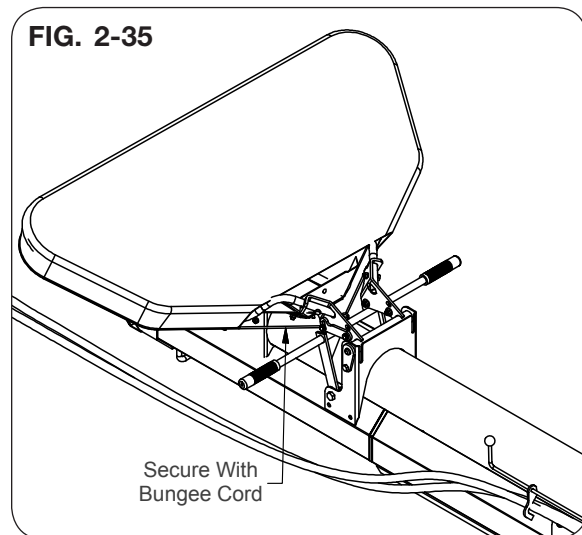

## Attaching The Conveyor

**NOTE:** Park the unit on a firm, level surface. Block the tires on the machine to keep it from moving. Set the tractor's parking brake, shut-off the engine and remove the ignition key.

1. Using a safe lifting device rated at 500 lbs. minimum, lift the conveyor assembly into the mounting position as shown in FIG. 2-36 & FIG. 2-37.
  - a. The conveyor assembly will rest in the pivot car/slide rail assembly (2003135B).
  - b. Place collar (25376B) onto the bottom of the pivot car/slide rail assembly (2003135B). Secure collar (25376B) with 3/8"-16UNC x 3-1/2" capscrew (9390-065). Tighten hardware according to "Torque Chart".

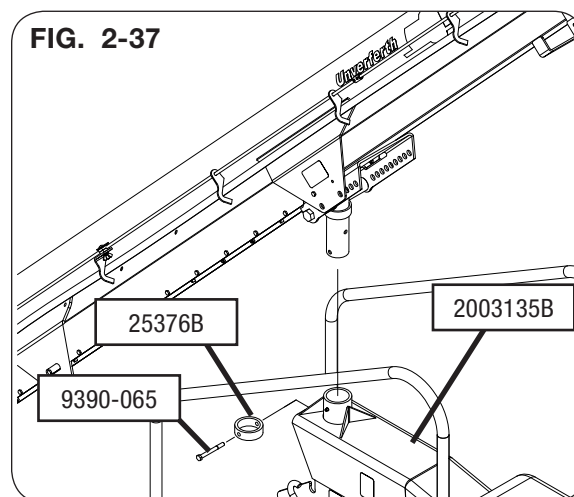
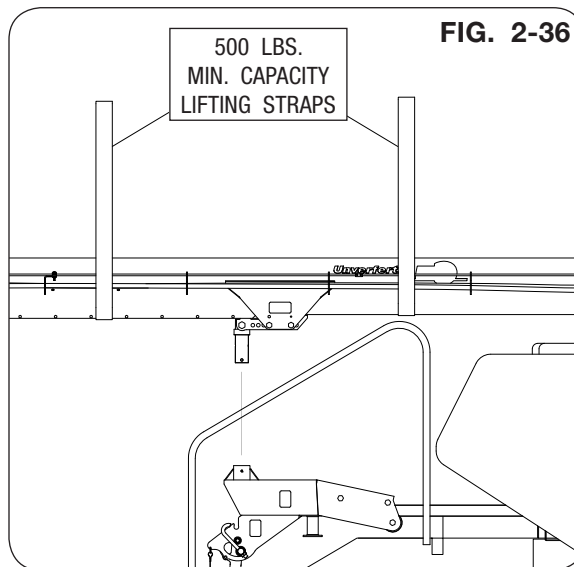

### Telescopic Spout Assembly

1. Remove the spout weldment with metal latch (26620B) and attach it to the discharge end/upper conveyor end.
2. Attach the telescopic spout assembly (27629) to the discharge end/upper conveyor using clamp (98060). Slide the spout on until it connects with the main conveyor and secure. Place spout on the spout hanger when not in use.

Spout holder may need to be readjusted to securely hold the telescopic spout. Adjust holder as needed and retighten hardware.

**Telescopic Spout Assembly  
For Planters With Refuge Tanks**

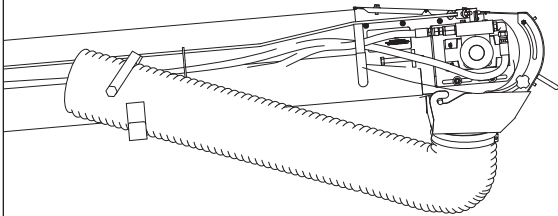

**FIG. 2-39**

**Telescopic Spout Assembly  
For Non-Refuge Tank Planters**

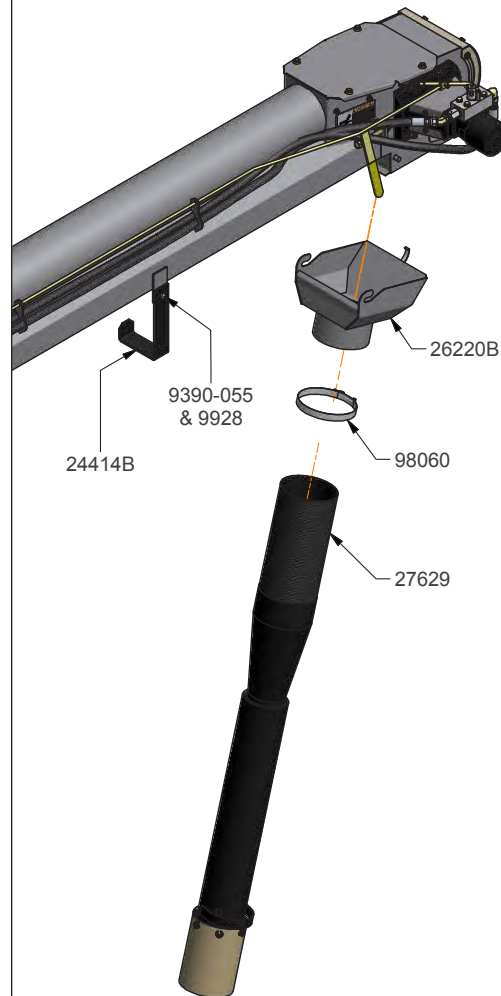

**FIG. 2-40**



**Optional Hopper Lift Stand Bundle #26588B**

**⚠ WARNING**

- **EXCESSIVE WEIGHT ON HOPPER LIFT STAND CAN CAUSE LIFT STAND TO COLLAPSE RESULTING IN SERIOUS INJURY OR DEATH. DO NOT PLACE BULK SEED BAGS OR CONTAINERS DIRECTLY ON OR IN HOPPER.**

1. Raise hopper end of tube conveyor using a safe lifting device rated for 200 lbs. min.
2. Place tube conveyor on properly rated jack stands.
5. Attach the hopper lift stand using four 3/8"-16UNC x 3/4" capscrews (9390-053) and four 3/8"-16UNC lock nuts (9928). See FIG. 2-41.

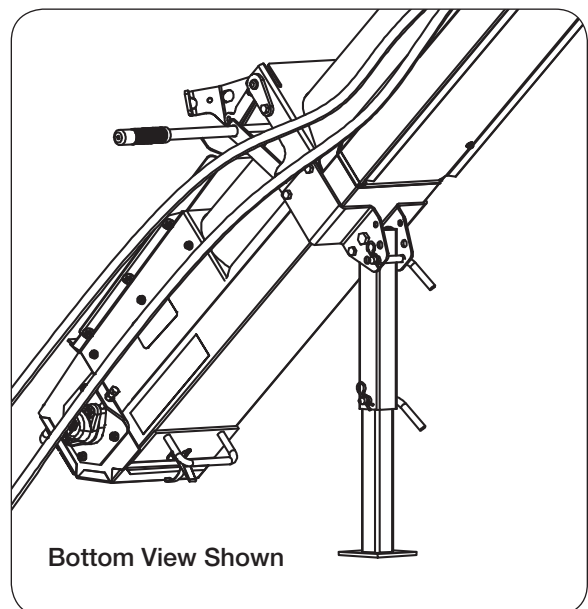
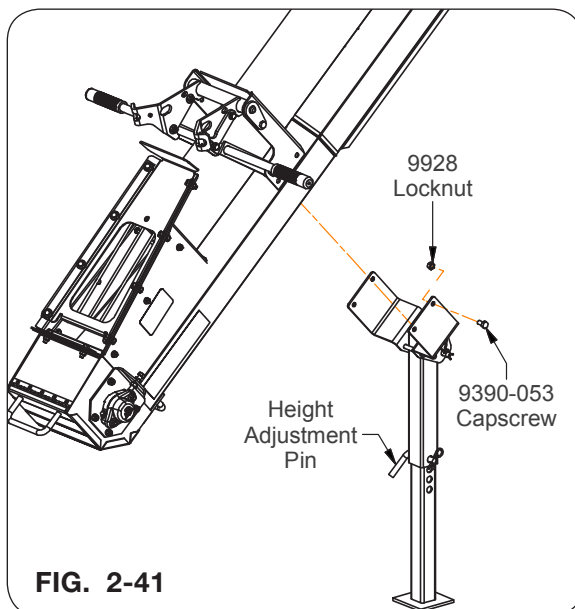

**Hopper Lift Stand Bundle (continued)**

6. Bent pin (900803) location:

Place bent pin (900803) into bottom hole of plate (26586B) when conveyor is in use. See FIG. 2-42.

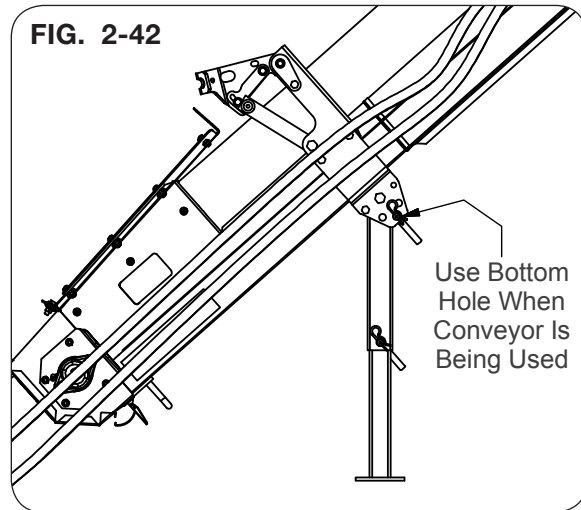

Place bent pin (900803) into upper hole of plate 26586B) when conveyor is in transport position. See FIG. 2-43.

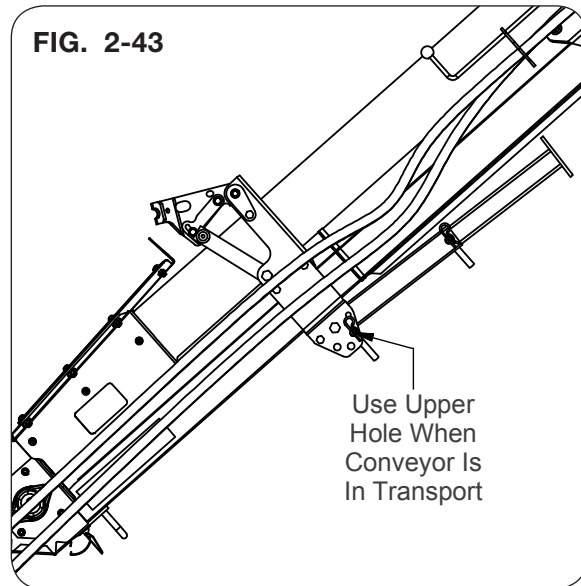

## Relocating SMV

1. The SMV Emblem and bracket have to be moved for optimum visibility. Move the SMV bracket from the original mounting position at the top of the railing steps and reattach it to the new mounting position on the vertical post weldment as shown in FIG. 2-44 & FIG. 2-46.
2. Drill a 13/32" hole in the SMV mounting bracket as shown in FIG. 2-45.
3. Using the SMV bracket as a template, mark the position for the additional holes as shown in FIG. 2-45.
4. Drill 3/16" holes at the marked location and secure using self-drilling screws (96972) as shown in FIG. 2-45.

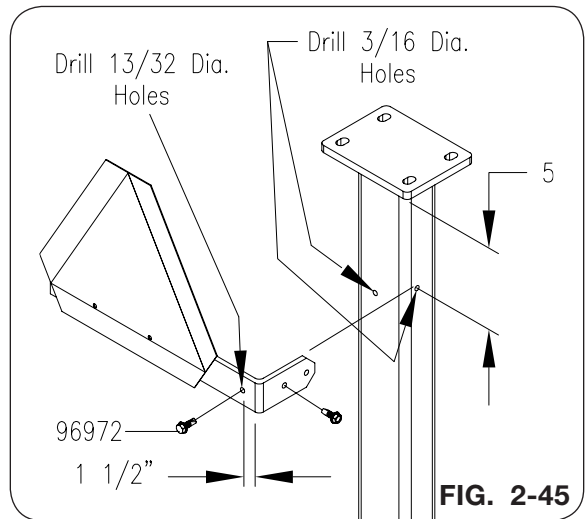
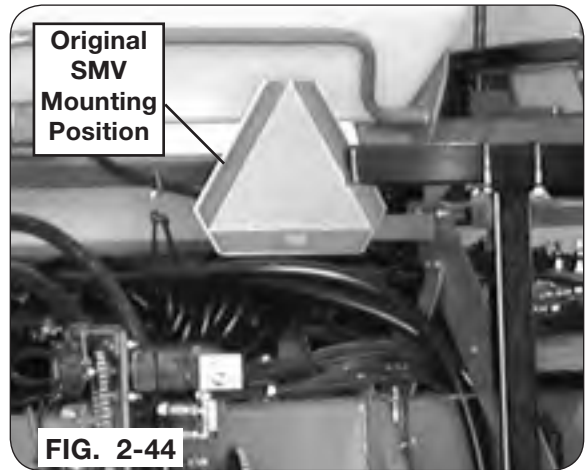

### Relocating SMV (continued)

5. Planters which have the optional fertilizer tanks will have to reposition the conveyor transport plates as shown in FIG. 2-47.

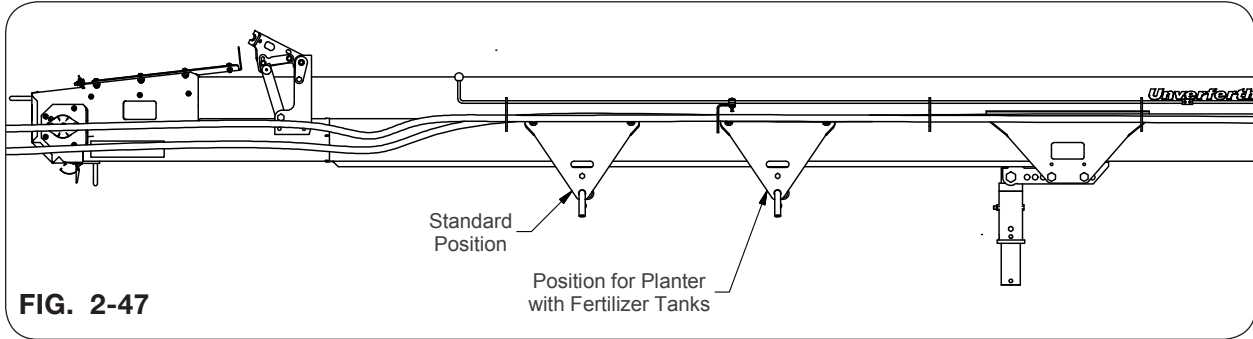

FIG. 2-47

### IMPORTANT

- *Repositioning the conveyor will increase the overall length when the conveyor is in the transport position by approximately 24".*
6. Be certain clearance to rafters, walls, machinery, etc. exists before lowering the conveyor. With a tractor hooked to the unit, activate the conveyor to make sure everything moves freely. Do not pinch or kink hoses.
  7. Check for and correct any leaks. Make sure hoses are not kinked, stretched, or twisted. Secure hoses to prevent cuts or chafing during operation.

## Hydraulics

### **WARNING**

- **HYDRAULIC SYSTEM MUST BE PURGED OF AIR BEFORE OPERATING TO PREVENT SERIOUS INJURY OR DEATH.**
  - **RELIEVE THE HYDRAULIC SYSTEM OF ALL PRESSURE BEFORE ADJUSTING OR SERVICING. SEE THE HYDRAULIC POWER UNIT OPERATOR'S MANUAL FOR PROPER PROCEDURES.**
  - **HIGH-PRESSURE FLUIDS CAN PENETRATE THE SKIN AND CAUSE SERIOUS INJURY OR DEATH. USE CARDBOARD OR WOOD TO DETECT LEAKS IN THE HYDRAULIC SYSTEM. SEEK MEDICAL TREATMENT IMMEDIATELY IF INJURED BY HIGH-PRESSURE FLUIDS.**
1. Route the hydraulic hoses around the slide rail arms as shown in FIG. 2-48 & FIG. 2-49. Be sure the hoses are not kinked or rubbing any sharp edges. Secure with 32" cable ties (94038).

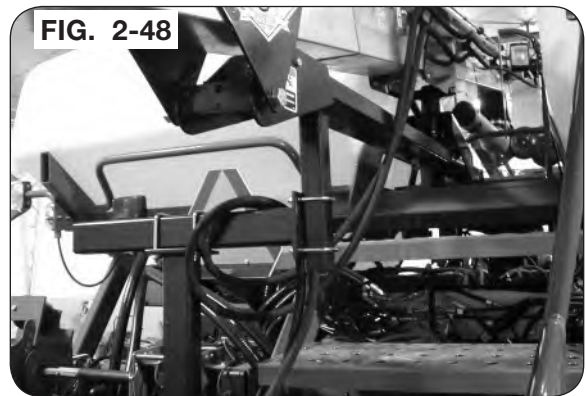

### Hydraulics (continued)

2. Attach the adapters (9864) to the opposite ends of the hoses (96758) (FIG. 2-50). Attach the hoses to the side of the conveyor using the hose retainers.
3. Thread the hoses through the loop on the dust cap (91511) (FIG. 2-50).
4. Attach the male tip couplings (91383) to the adapter end of the hoses (FIG. 2-50). Tighten all the fittings completely.

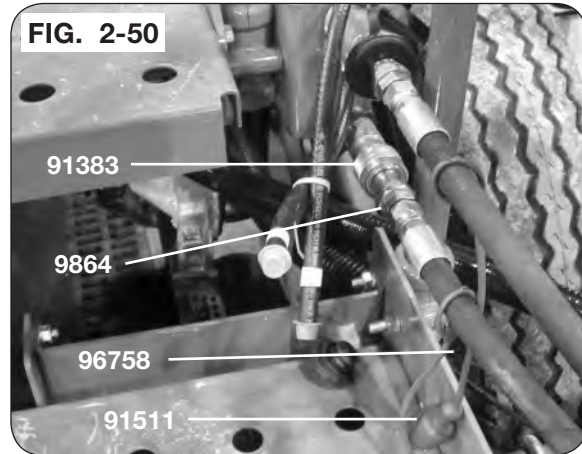

5. Insert the coupling end of the hoses into the planter auxiliary valve with a maximum 12 GPM. If not using an auxiliary valve, attach additional lines directly to the tractor ports.

### IMPORTANT

- Hoses are provided to the optional John Deere auxiliary ports on the rear of the planter. It is not recommended that you tie into the planter hydraulics without this option. Contact your JD dealer for more information. Hoses may be lengthened to tie directly into the tractor ports (these hoses are not provided).

**Rear View Layout**

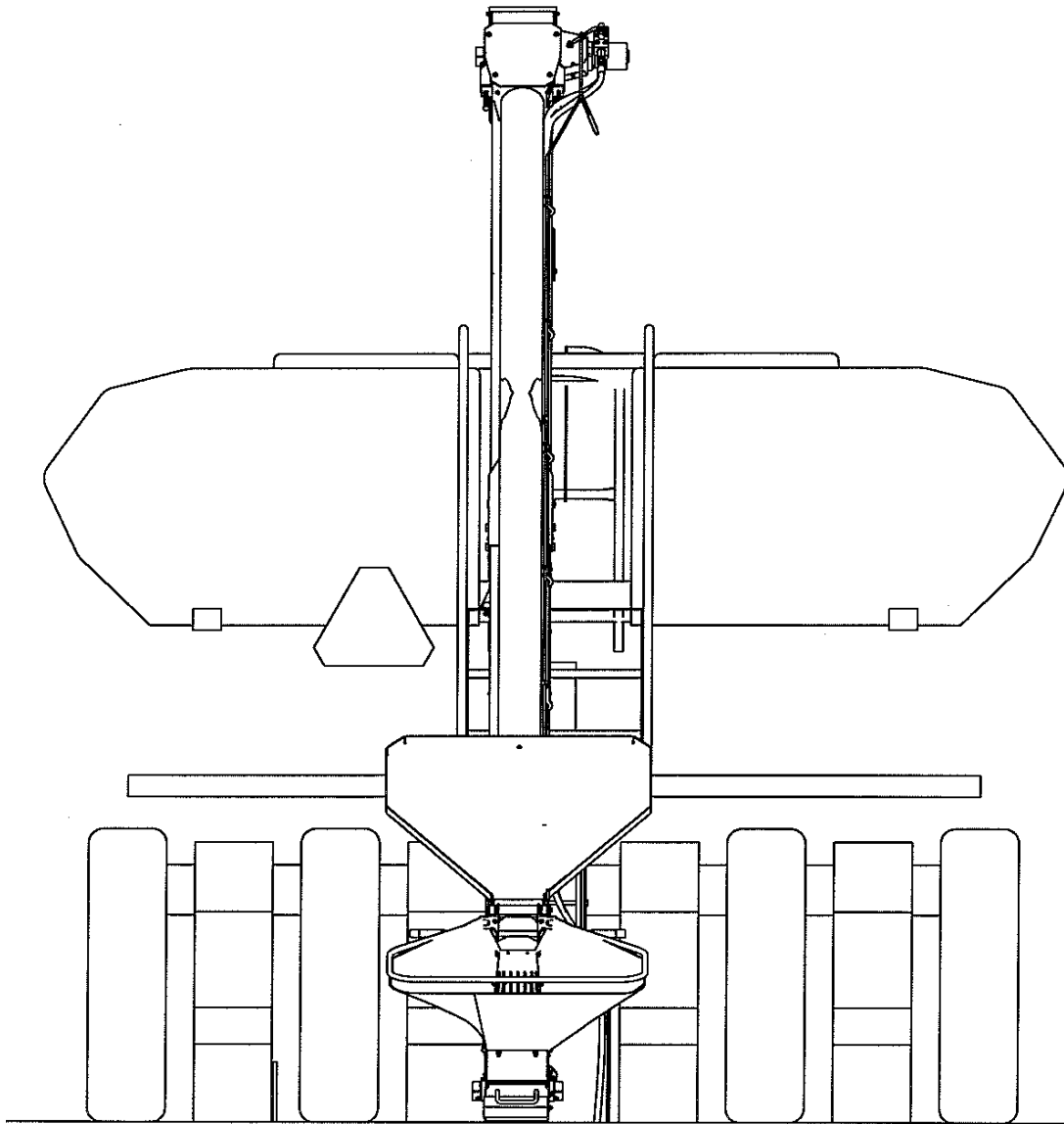

### Reattach Light

1. With the conveyor in the transport position, raise the hand rail up so that the conveyor will clear it. Tighten hardware according to Torque Chart.
2. Attach the light previously removed as shown in FIG. 2-51 using the existing hardware. Be sure that when the conveyor is maneuvered, it will clear the light. Secure the wiring harness with 6" cable ties.



FIG. 2-51



## Hydraulic Flow Control Valve Kit #23669

Tractors having high-capacity hydraulic systems with 12 to 20 GPM flow, may cause your conveyor to run too fast, resulting in:

- A. Excess Vibration
- B. Excess Wear
- C. Loss of Performance

To eliminate these problems, an adjustable flow control valve is offered for installation into the conveyor hydraulic system. This valve will allow the operator to adjust the flow to obtain the proper speed for your application.

### **⚠ WARNING**

- **EYE PROTECTION AND OTHER APPROPRIATE PERSONAL PROTECTIVE EQUIPMENT MUST BE WORN WHILE SERVICING IMPLEMENT.**
- **RELIEVE THE HYDRAULIC SYSTEM OF ALL PRESSURE BEFORE ADJUSTING OR SERVICING. SEE THE HYDRAULIC POWER UNIT OPERATOR'S MANUAL FOR PROPER PROCEDURES.**
- **HIGH-PRESSURE FLUIDS CAN PENETRATE THE SKIN AND CAUSE SERIOUS INJURY OR DEATH. USE CARDBOARD OR WOOD TO DETECT LEAKS IN THE HYDRAULIC SYSTEM. SEEK MEDICAL TREATMENT IMMEDIATELY IF INJURED BY HIGH-PRESSURE FLUIDS.**

1. Determine the type of hydraulic system and plumb according to the diagrams below. Contact your local dealer to identify which system your tractor is equipped with.

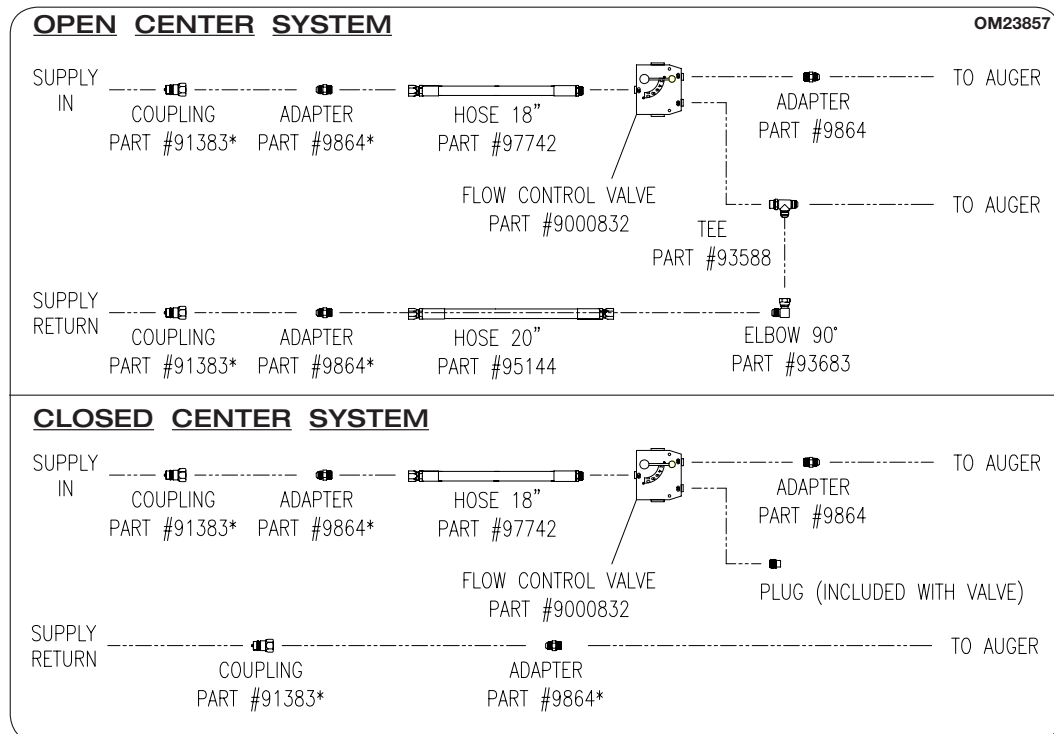

\* Parts are included with conveyor.

### Hydraulic Flow Control Valve Kit #23669 (continued)



2. Once hydraulics are assembled, position valve on outside of stairs and mark holes for drilling. Drill two 9/32" holes.
3. Mount valve and secure using two 1/4" bolts and locknuts provided.
4. Install handle onto valve as shown.

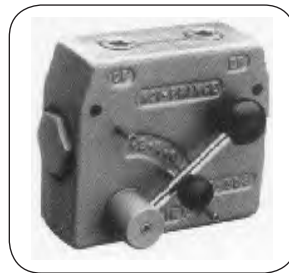

5. Once the control valve is installed, the conveyor speed can be set as follows:
  - A. Set flow control valve approximately 1/2 way on flow indicator (lock into position).
  - B. Start oil flow and run conveyor to check speed. Belt should run smooth, not lag or fluctuate in speed, adjust speed control valve if necessary.

**NOTE:** When conveyor is loaded with material, it should not stall. Adjust speed to allow for smooth, even feeding of material through the unit.

## Optional Anti-Reverse Check Valve Kit #23336

The optional check valve kit (23336) will allow the auger to only run forward.

### **⚠ WARNING**

- RELIEVE THE HYDRAULIC SYSTEM OF ALL PRESSURE BEFORE ADJUSTING OR SERVICING. SEE THE HYDRAULIC POWER UNIT OPERATOR'S MANUAL FOR PROPER PROCEDURES.
- HIGH-PRESSURE FLUIDS CAN PENETRATE THE SKIN AND CAUSE SERIOUS INJURY OR DEATH. USE CARDBOARD OR WOOD TO DETECT LEAKS IN THE HYDRAULIC SYSTEM. SEEK MEDICAL TREATMENT IMMEDIATELY IF INJURED BY HIGH-PRESSURE FLUIDS.

**NOTE:** Be sure to disconnect hydraulics while working in an environment clean of dirt and debris. If dirt should enter into system, flush system. Failure to remove dirt could result in motor failure or damage to system supply.

**NOTE:** "A" port will be located on the right-hand side of the auger. To determine the right-hand side, stand at the hopper end of the auger and look towards the motor end.

**NOTE:** The Check Valve must be installed on the return side of the motor in order to work properly.

1. Relieve hydraulic pressure and disconnect hydraulic line from PORT "A" on top of auger tube.
2. Connect 3/4"-16 male/male adapter (9864) to PORT "A".
3. Insert the check valve (97740) onto adapter in direction shown in FIG. 2-52.
4. Insert 3/4"-16 male/female adapter (96935) into check valve and reconnect return line.

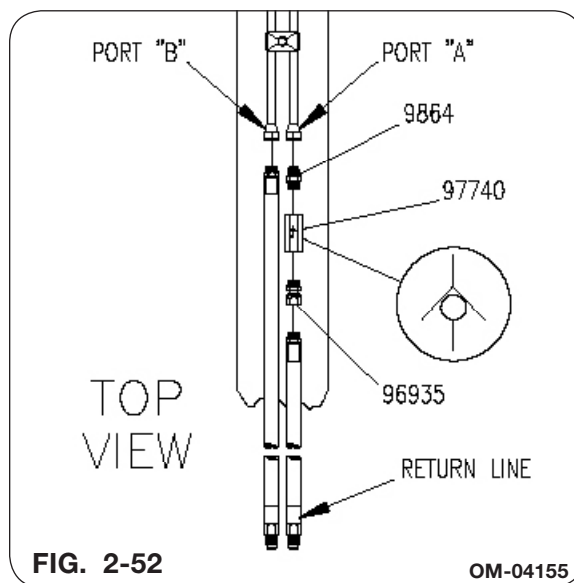

**Optional Planter Fill-Conveyor Belt Stretcher  
For Replacement of Cleated Belts**

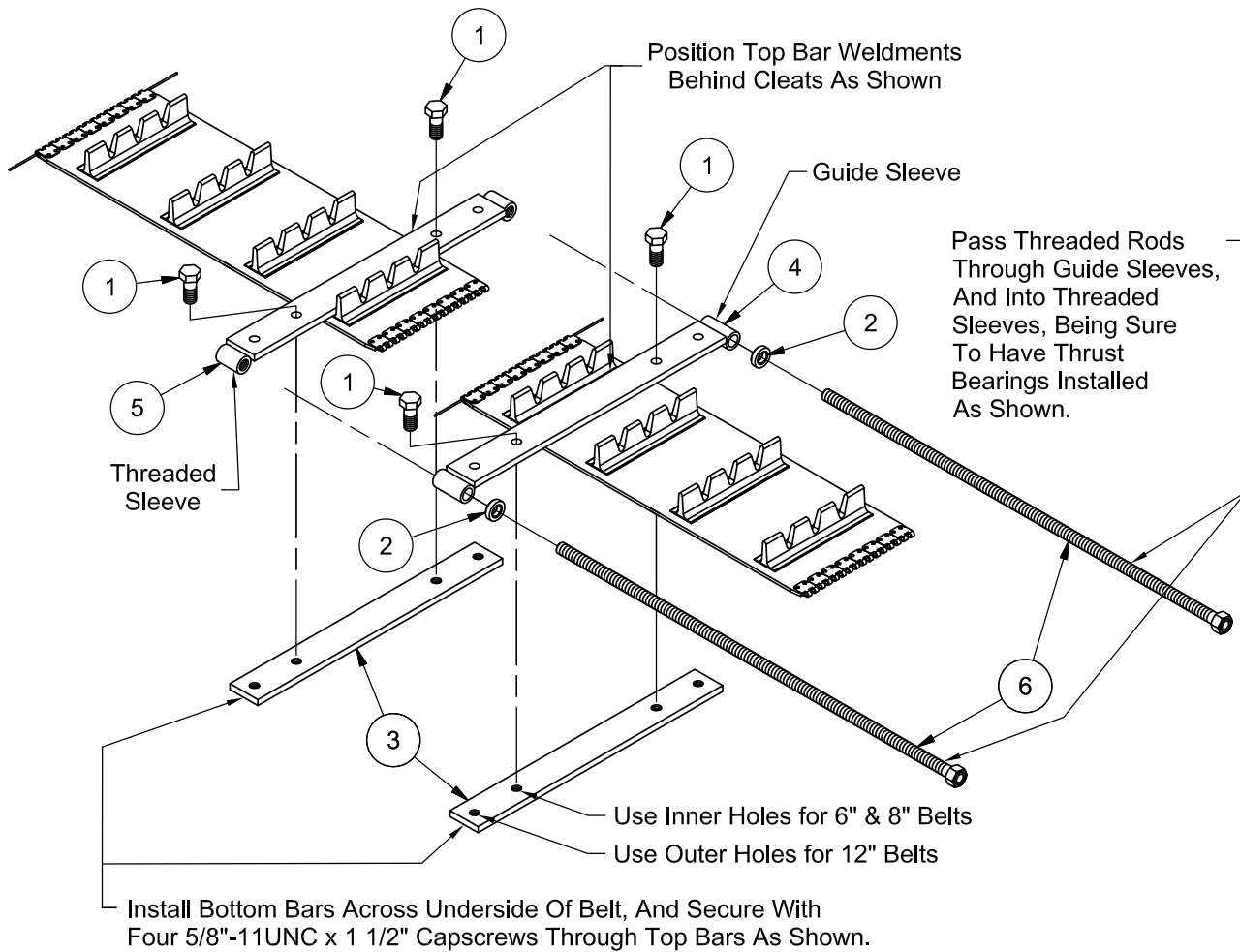

Parts List			
ITEM	P/N	QTY	DESCRIPTION
1	9390-122	4	HCS 5/8X1 1/2 UNC GR5
2	TA0-903118-0	2	BALL BEARING
3	OMTA1-114401-0	2	BOTTOM BAR
4	OMTA2-114404-0	2	PLAIN TOP BAR WELDMENT
5	OMTA2-114406-0	2	THREADED TOP BAR WELDMENT
6	OMTA2-114408-0	2	THREADED ROD WELDMENT

**Stretcher Assembled to Belt**

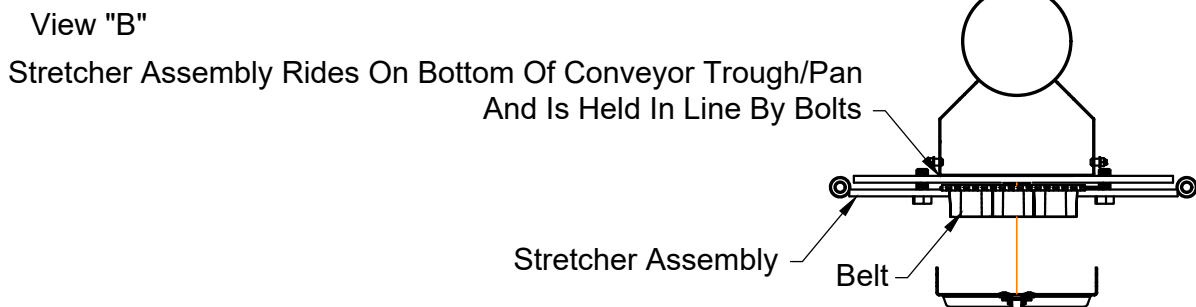
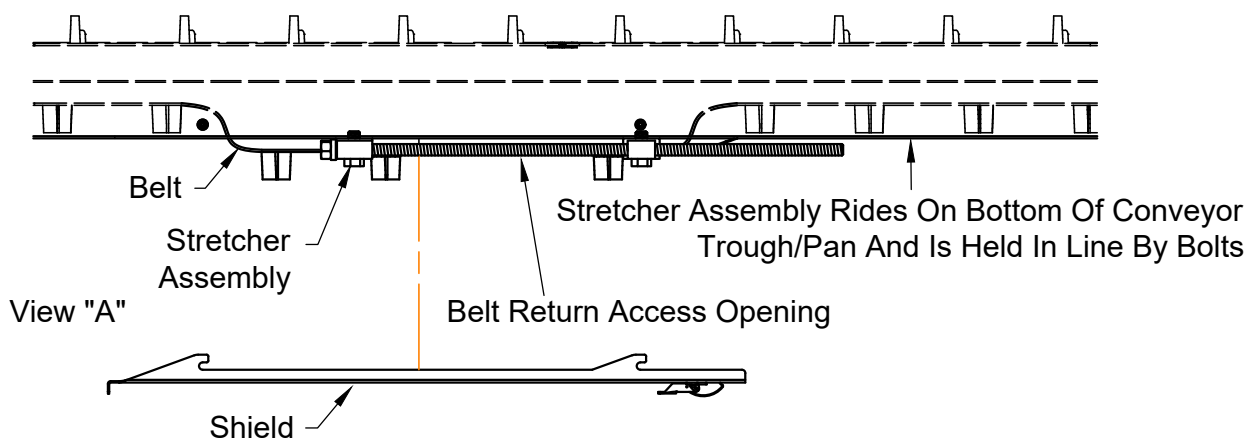
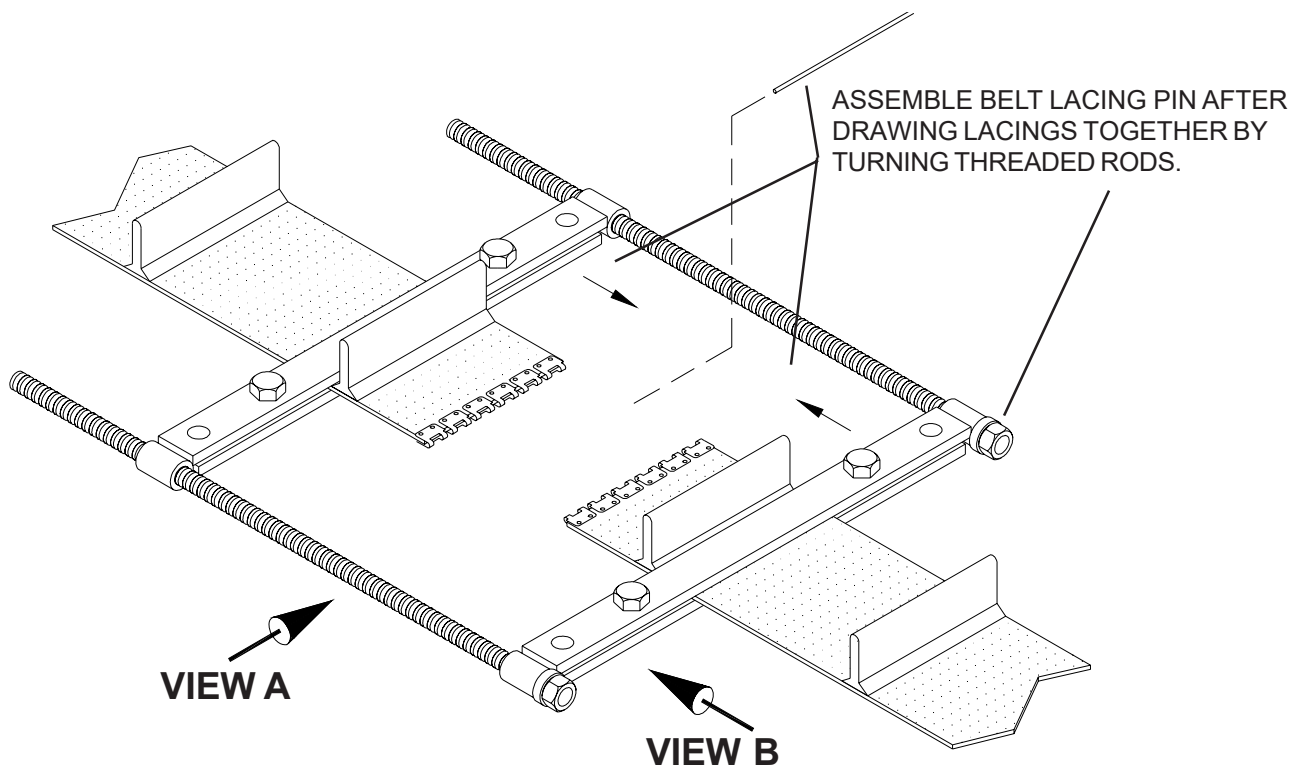

**Notes**

# **SECTION III**

# **Operation**

Preparing Planter .....	3-2
Operating Procedures.....	3-2
Transporting.....	3-6
Hydraulics .....	3-7
Clean-Out Doors .....	3-8



## Preparing Planter

### **WARNING**

- READ AND UNDERSTAND SAFETY RULES BEFORE OPERATING OR SERVICING THIS MACHINE. REVIEW "SAFETY" SECTION IN THIS MANUAL IF NECESSARY.

Read this operation section thoroughly. Acquaint yourself with the adjustments required to obtain efficient and trouble-free operations.

## Preparing Planter

### **IMPORTANT**

- Before attempting to attach the planter to the tractor, familiarize yourself with operations and adjustments of the unit. To insure safe operating conditions, obey all "Safety" and "Cautions" outlined in the planter's operator's manual.

## Operating Procedures

### **CAUTION**

- KEEP ALL UNAUTHORIZED PEOPLE CLEAR OF WORK AREA.

1. Pull tractor and planter into position, shift tractor into park (or neutral) and lock brakes on tractor. Planter must be lowered to the ground to fill.
2. Open the lid on the planter tanks to allow the conveyor to be positioned.
3. Remove the lynch pin (9951) from the transport bracket as shown in FIG. 3-1.
4. Lift up on the transport handle to release the hooks retaining the conveyor.

FIG. 3-1

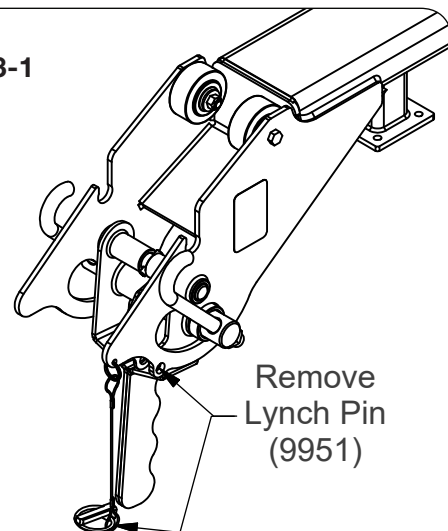

**Operating Procedures (continued)**

5. Lower the conveyor into operating position as shown in FIG. 3-2.



## Operating Procedures (continued)

**NOTE:** Adjust the position of the conveyor using the hole settings in the conveyor channel to determine the spout height and bushel flow (reference FIG. 3-3).

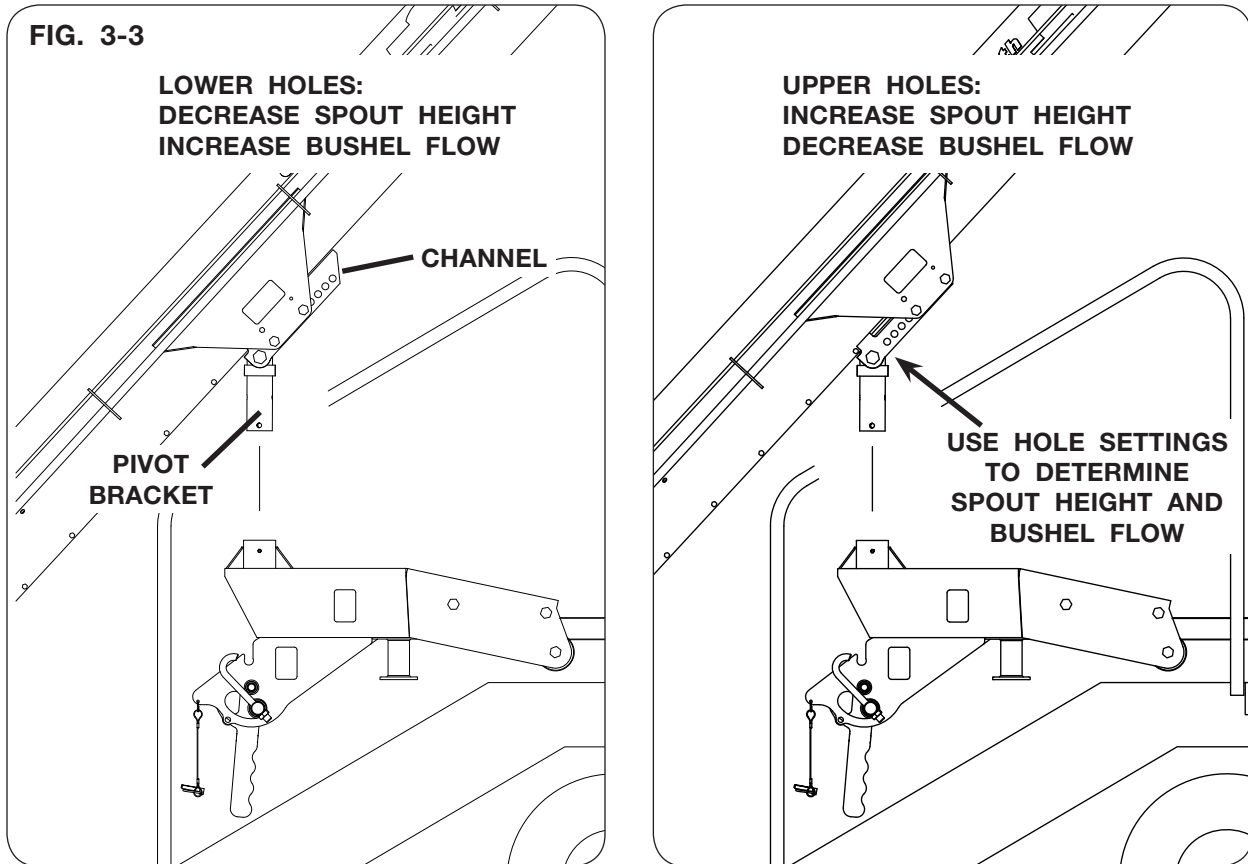

### IMPORTANT

- Do not let telescoping spout rest in bottom of seed box. Seed will rapidly build up and plug conveyor, resulting in potential damage to belt.
  - Be sure shims are assembled to minimize gap between channel and side plates. Do not draw bolts to minimize gaps, else premature belt wear might occur. Refer to SET UP section for details.
6. Engage the tractor hydraulic system to allow the hydraulic oil to flow to the conveyor. Turn on conveyor by sliding manual control lever to on position. Make sure the conveyor belt is moving in a forward direction. If the belt is moving in a backward direction, either reverse the hoses going into the tractor or move the tractor control hydraulic lever in the opposite direction to reverse the flow.

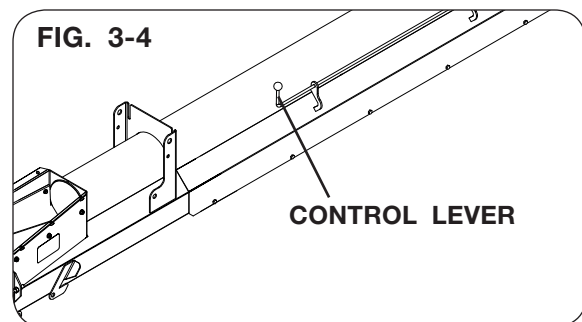

### Operating Procedures (continued)

#### **WARNING**

- SEED MAY BE TREATED WITH HAZARDOUS MATERIAL. AVOID CONTACTING SEED WITH SKIN, EYES, AND AVOID BREATHING DUST. FOLLOW MANUFACTURER'S RECOMMENDATIONS.

7. Begin the flow of seed into the conveyor. Adjust the seed flow for a smooth, even flow of seed through the conveyor.
8. Fill the tank evenly by moving the adjustable spout from side-to-side while the conveyor is running. When the desired level is reached in the tank(s), close the transfer wagon door and empty out the conveyor.

#### **IMPORTANT**

- *When rotating conveyor from side-to-side, be sure to not over-rotate. Gas shock may be bent resulting in loss of pressure.*

## Transporting

1. Remove the lynch pin from the transport latch bracket. Place the conveyor back into the transport latch bracket. Lift the latch handle. Place the hooks on the conveyor bracket. Lower the latch handle and replace the lynch pin to keep the conveyor in place. (FIG. 3-5)



2. Place the spout in the spout holder as shown in FIG. 3-6.

### IMPORTANT

- Always position the conveyor in transport position when not filling the planter.

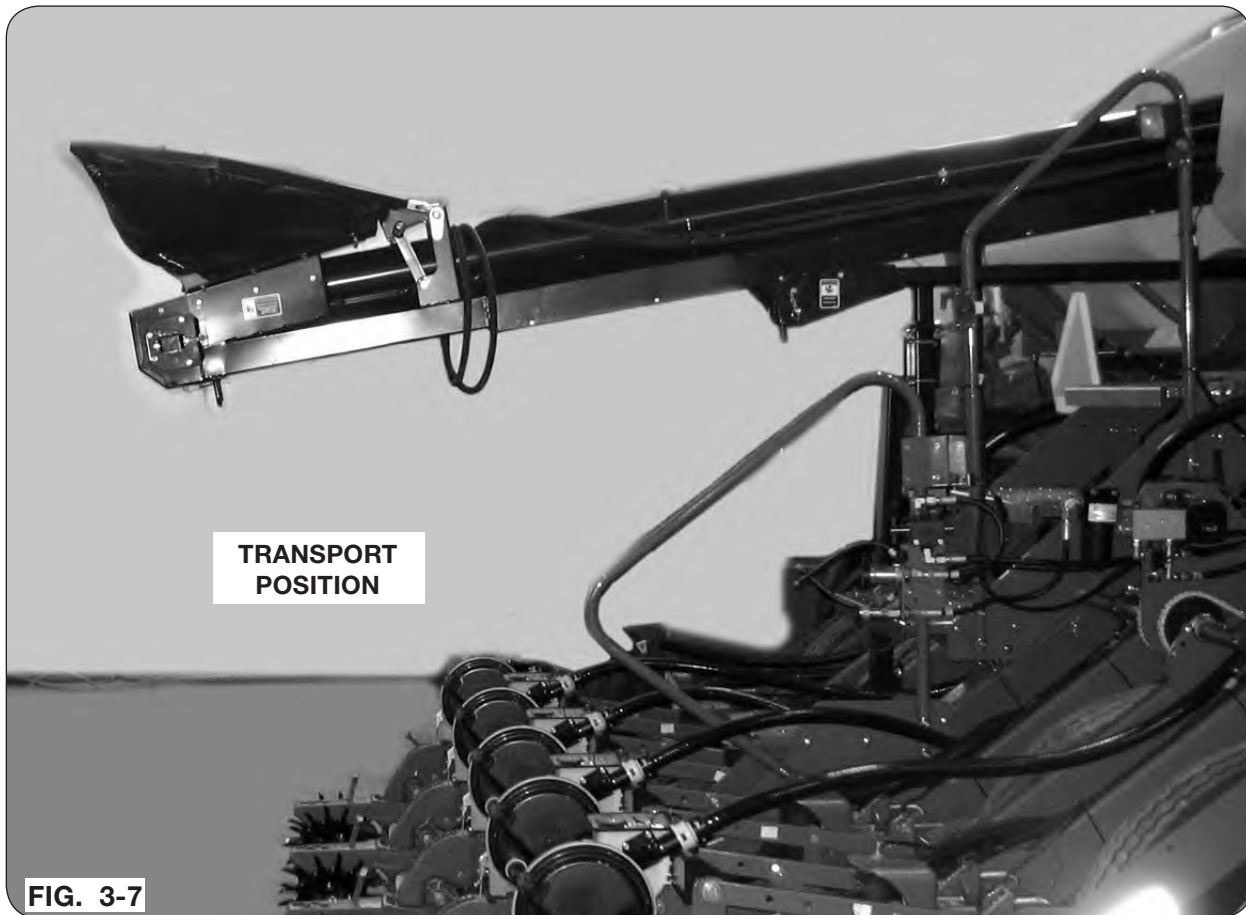
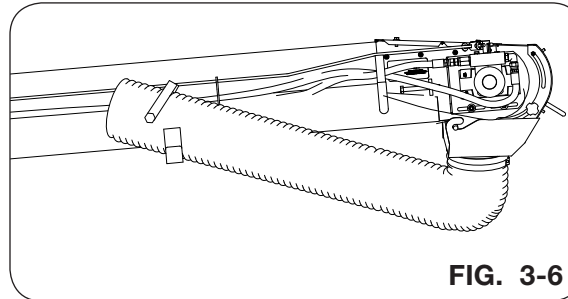

## Hydraulics

### **WARNING**

- **HYDRAULIC SYSTEM MUST BE PURGED OF AIR BEFORE OPERATING TO PREVENT SERIOUS INJURY OR DEATH.**

---

- **RELIEVE THE HYDRAULIC SYSTEM OF ALL PRESSURE BEFORE ADJUSTING OR SERVICING. SEE THE HYDRAULIC POWER UNIT OPERATOR'S MANUAL FOR PROPER PROCEDURES.**

---

- **HIGH-PRESSURE FLUIDS CAN PENETRATE THE SKIN AND CAUSE SERIOUS INJURY OR DEATH. USE CARDBOARD OR WOOD TO DETECT LEAKS IN THE HYDRAULIC SYSTEM. SEEK MEDICAL TREATMENT IMMEDIATELY IF INJURED BY HIGH-PRESSURE FLUIDS.**

---

Check routing of all hydraulic hoses. Hoses should not be kinked, twisted, or rubbing against sharp edges. Hoses should be secured with tie straps. Check hose fittings for hydraulic leaks. Tighten and/or repair or replace as required (FIG. 3-8).

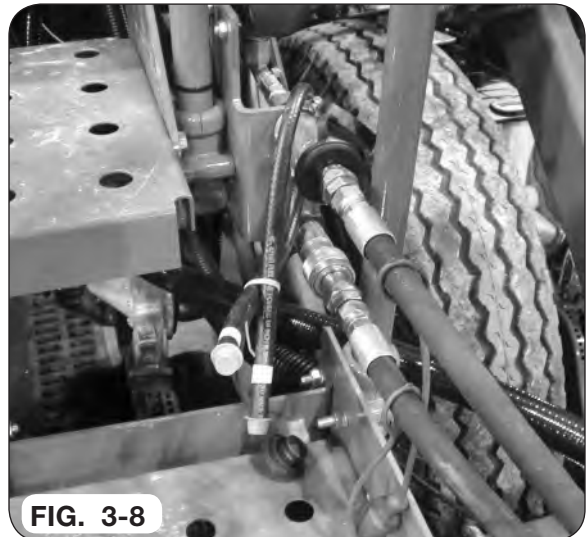

## Clean-Out Doors

### **⚠ WARNING**

- **MOVING OR ROTATING COMPONENTS CAN CAUSE SERIOUS INJURY OR DEATH. ALWAYS DISCONNECT POWER SOURCE BEFORE SERVICING. ENSURE SERVICE COVERS, CHAIN/BELT COVERS AND CLEAN-OUT DOOR(S) ARE IN PLACE AND SECURELY FASTENED BEFORE OPERATING MACHINE.**

The hopper end of the conveyor can be cleaned by releasing the latch and opening the clean-out door (FIG. 3-9). The conveyor discharge head can be cleaned by releasing the latch and opening the clean-out door (FIG. 3-9).

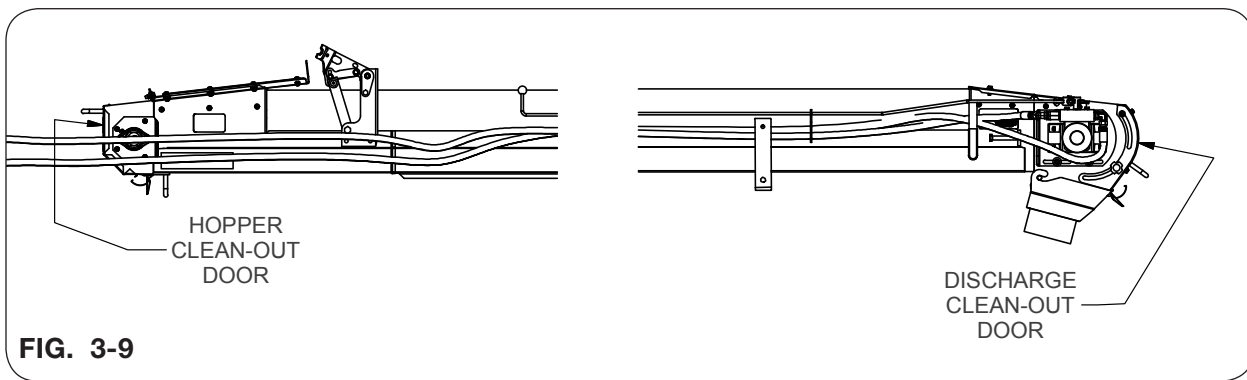



# **SECTION IV**

# **Maintenance**

Lubrication .....	4-2
Conveyor Bearings.....	4-2
Miscellaneous Lube Points .....	4-2
Storage/Maintenance .....	4-2
Hydraulic System.....	4-3
Conveyor Belt .....	4-4
Belt Tension.....	4-4
Belt Tracking.....	4-5
Belt Replacement .....	4-7
Troubleshooting .....	4-8
Torque Chart .....	4-10
Hydraulic Fittings.....	4-10

### Lubrication

Lubricate with an SAE multi-purpose grease. All fittings must be free from dirt and paint to insure entry of lubricant inside bearing.

### Conveyor Bearings

Lubricate this bearing every 100 hours of operation and at the end of each season before storage. Use only one stroke of grease per bearing.



### CAUTION

- DO NOT USE A HIGH-PRESSURE GREASE GUN TO LUBRICATE THIS BEARING, AS DAMAGE TO BEARING SEAL COULD OCCUR.

NOTE: Excessive lubrication of these bearings will result in premature failure.

### Miscellaneous Lube Points

Oil or grease periodically (or as needed) the following:

- Hinge for clean-out door.
- Swivel base on conveyor.
- Latch pin housing.
- Pivot bracket and arm.
- On/Off control rod.

### Storage/Maintenance

Your conveyor is an important investment. Spend a little time to protect it from destructive rust and corrosion. You will be repaid in longer service life and better performance.

#### DO THE FOLLOWING AFTER USE:

1. Clean out conveyor/hopper. Use pressurized water to wash out conveyor and hopper after use.
2. Wipe off the following:
  - Hydraulic valve, motor, hoses, and fittings.
  - Swivel base, cradle.
  - Reflectors and warning/caution decals.
3. Check the following:
  - Mounting bolts for tightness.
  - Cable ties for tightness.
  - Valve, motor, hoses, and fittings for leaks, etc.
  - Hydraulic hoses for wear-abuse.

#### DO THE FOLLOWING BEFORE PLACING THE CONVEYOR IN STORAGE:

- Repaint any chipped or scraped areas.
- Inspect for damaged or worn parts. Replace before next season.
- Store unit inside, away from livestock.

### Hydraulic System

#### **WARNING**

- RELIEVE THE HYDRAULIC SYSTEM OF ALL PRESSURE BEFORE ADJUSTING OR SERVICING. SEE THE HYDRAULIC POWER UNIT OPERATOR'S MANUAL FOR PROPER PROCEDURES.
- HIGH-PRESSURE FLUIDS CAN PENETRATE THE SKIN AND CAUSE SERIOUS INJURY OR DEATH. USE CARDBOARD OR WOOD TO DETECT LEAKS IN THE HYDRAULIC SYSTEM. SEEK MEDICAL TREATMENT IMMEDIATELY IF INJURED BY HIGH-PRESSURE FLUIDS.

Refer to parts section for hydraulic component detail listing.

When properly assembled and maintained, the hydraulic system of the conveyor requires little maintenance.

#### Replacing Hoses/Fittings/Cylinders:

1. Use replacement hoses, fittings, and cylinders from your Unverferth Manufacturing dealer which are rated for 3000 psi.
2. Do not use hoses, fittings and cylinders that have pipe threads.
3. Do not use Teflon tape or thread sealant on JIC or O-ring fittings. Tighten fittings per "Torque Chart".
4. When replacing hoses, always allow sufficient slack to permit hoses to move through the full range of motion of the cylinders.
5. Always purge the hydraulic system after servicing.

## Conveyor Belt

Proper belt tension and correct ‘tracking’ of the belt are critical to maintaining the belt for years of worry-free use. Belt tension and tracking should be checked at the beginning of each season. Belt alignment should be checked after the very first initial use then after the first 2 hours of initial use or after every adjustment of belt tension/alignment. Once belt tracking is set, it will be necessary to check alignment after every 8 hours of use.

### **⚠ WARNING**

- AVOID PERSONAL ATTIRE SUCH AS LOOSE FITTING CLOTHING, SHOESTRINGS, DRAWSTRINGS, PANTS CUFFS, LONG HAIR, ETC., THAT MAY BECOME ENTANGLED IN MOVING PARTS
- MOVING OR ROTATING COMPONENTS CAN CAUSE SERIOUS INJURY OR DEATH. USE EXTREME CARE WHEN INSPECTING AND ADJUSTING BELT TRACKING.

## Belt Tension

Belt tension is inspected by removing lower intake panel/guard from conveyor, and gently pull on the conveyor belt. The belt should have approximately 1 1/2-2” of slack at the center.

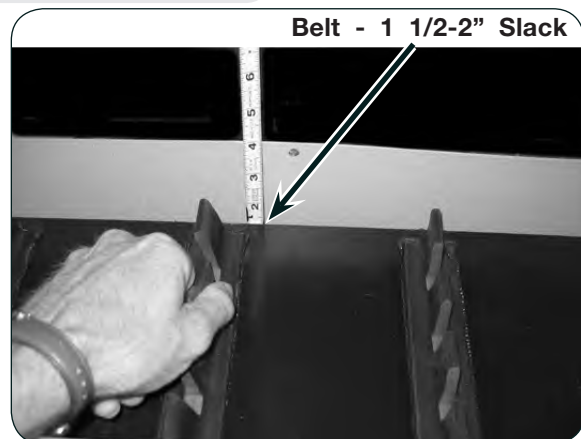

Belt tension is adjusted at the discharge end of the conveyor. Loosen, DO NOT REMOVE, the four 3/8" bolts on each side of the conveyor. Use the two adjusting bolts to adjust the belt to the proper tension.

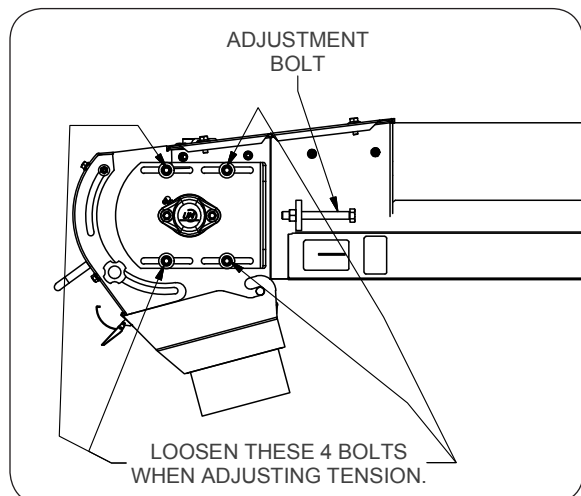

It is important to move both sides the same distance. Too much tension on the belt will stretch the splice link and greatly reduce belt life. Too little tension on the belt could result in belt slipping on drive pulley. Replace the bottom cover panel and continue to check belt tracking before re-tightening the four bolts on each side of the conveyor.

## Conveyor Belt (continued)

### IMPORTANT

- *Belt tracking must be done every time tension is adjusted.*

### Belt Tracking

Conveyor belt must always run at the center of the pulley on both the intake and discharge end. Improper tracking of the belt will result in excessive wear to the edge of the belt, and will greatly reduce belt life. Check belt tracking every 8 hours of use, and every time belt tension is adjusted.

Inspect tracking of belt at discharge end by removing lower spout, pivoting deflector up, and looking up at the belt and pulley. Belt should be in center of pulley.

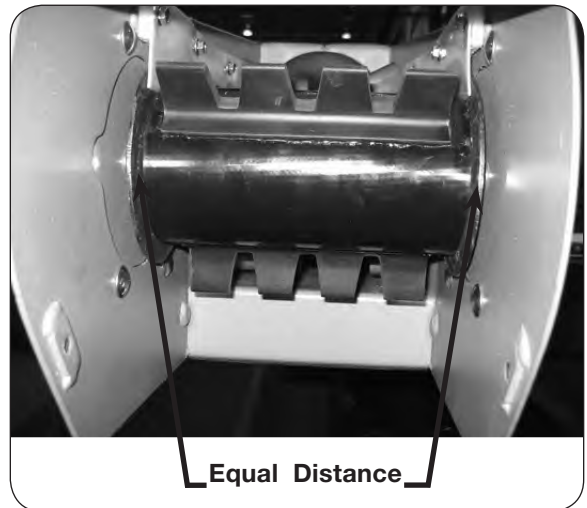

Adjust by loosening, **DO NOT REMOVE**, the four bolts on the side of the conveyor. Operate conveyor at slow speed, and tighten or loosen the adjustment bolt until belt is running in the center of the pulley.

**Conveyor Belt (continued)**

**Belt Tracking (continued)**

Tighten all bolts on side of conveyor, and lock adjustment bolts into place.

Inspect tracking of belt at intake end by opening bottom inspection door on conveyor. Belt should be in the center of the pulley.

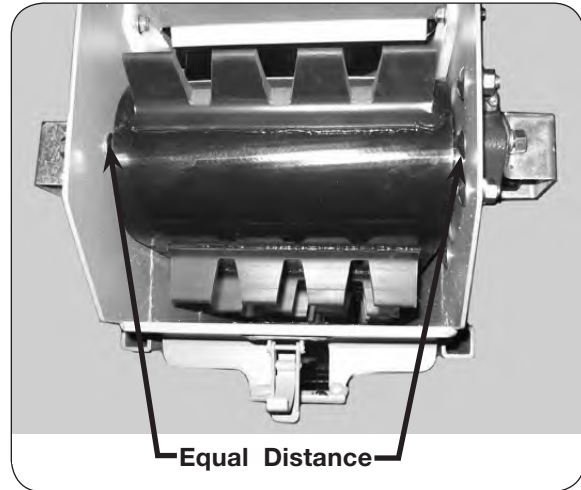

Adjust by loosening (Do Not Remove) the four bolts (two on each side) on the adjusting plate.

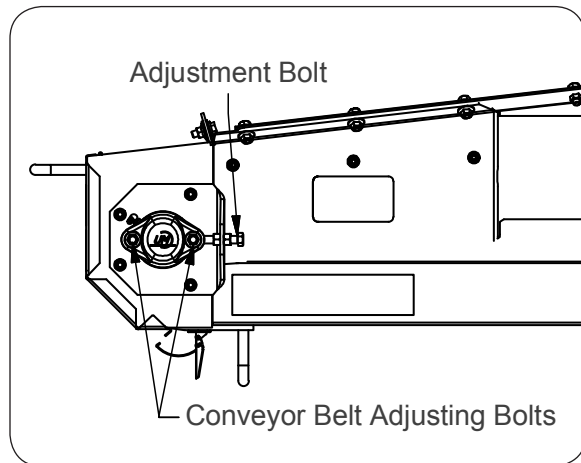

Operate conveyor at slow speed, and tighten or loosen adjustment bolt until belt is running in the center of the pulley.

Tighten the two bolts on the adjustment plate, and lock the adjustment bolt into place.

### Belt Replacement

1. Remove the access panel from the underside near the center of the conveyor housing.
2. Run the conveyor belt until the splice is positioned in the access opening.
3. Reduce tension from the belt by turning the tensioning bolts on the end of the conveyor.
4. Attach the belt stretcher to the belt to remove tension on the belt splice. Remove connecting wire from the splice.
5. Attach the new belt to the original belt splice using a length of small diameter wire.
6. Pull the original belt out of the conveyor. When finished, the new belt should be routed through the conveyor, remove the temporary splice wire and discard.
7. Reinstall the belt stretcher to the new belt to draw the splice together. Insert the vinyl coated cable through the splice, attach the small bent washers on each end of the cable by crimping tight with pliers. Remove the belt stretcher from the new belt.
8. Increase tension on the new belt by adjusting the tensioning bolts on the end of the conveyor housing, making sure the belt tracking is centered.
9. Install access panel door removed in step 1.



**Troubleshooting**

Occasionally when a conveyor has been connected into an auxiliary hydraulic system, it may not operate or convey the material being handled. When hydraulic pressure and flow gauges are not available, it may be difficult to determine if there is a fault in the source, hydraulic system, or the conveyor. A convenient method of determining this is to connect the conveyor hydraulic hoses to another tractor system and check the operation. If, for example, the conveyor operates from the other tractor system but not from the original tractor there is a fault in the original tractor connection, or the original tractor system is not adequate. If the conveyor fails to operate; however, there is probably a fault with the conveyor control valve, motor, or the conveyor itself. In this case, refer to the trouble shooting guide.

**PROBABLE CAUSE**

**CORRECTION**

**Conveyor Will Not Turn Over or Develop Proper Speed/Torque**

Pump does not deliver sufficient pressure or volume	Check output and delivery-repair if necessary
Conveyor mechanism binding	Check for cause and correct
Wrong hose hook-up to tractor control levers	Refer to Tractor Operator's Manual for valve and control lever arrangement
Insufficient tractor hydraulic pressure	See the following: A. Check hydraulic reservoir oil level B. See assembly section "Hydraulic Hook-Up Recommendations"
Hydraulic components leaking oil	Find cause and correct
Hydraulic hoses kinked or twisted	Find cause and correct
Malfunction of hydraulic components	Isolate problem area-repair as necessary

**Conveyor Runs Too Slow**

Pump is worn	Repair or replace pump
Internal leak in controls or motor	Replace seals; repair or replace valves or motors
Air in system	Bleed system and tighten connections
If conveyor starts slowly and speed increases after oil heats up; oil is too heavy weight. If conveyor slows down after oil heats up; oil is too light weight	Use proper weight hydraulic oil

**Troubleshooting (continued)**

PROBABLE CAUSE	CORRECTION
<b>Conveyor is Turning in Wrong Direction</b>	
Incorrect piping between source and control valve	Reverse piping connections
Improperly installed check valve plate	Reposition (As shown in SET-UP section)
<b>Oil Heat Excessively</b>	
Too light weight in hot climate	Drain and refill with proper weight oil.
Oil too heavy weight	Use recommended weight oil.
Dirty oil	Drain, flush, and refill with clean oil and filter
Oil level too low	Fill to proper level
Relief valve pressure too high or low; does not operate	Adjust and repair or replace relief valve
Oil slipping through worn pump	Repair or replace pump
Hoses or valves too small	Use larger hoses or valves
Restricted lines or piping	Reroute lines to eliminate restrictions
Reservoir too small to provide adequate cooling	Replace with larger reservoir or install oil cooler
<b>Pump/Motors/Seals Blow - Shaft/Housing Breaks - Hose Burst</b>	
When a standard control valve is returned to neutral to stop or start a motor, sudden excess pressure is created which will break seals, tear off motor shafts, burst housing or hoses, (Especially at speed under load.) This sudden shock cannot be relieved through the primary relief valve in the system.	Avoid sudden rapid starting and stopping
<b>Belt Edges Showing Excessive Wear</b>	
Belt tracking incorrect	Adjust tracking as detailed in MAINTENANCE section
Poly seals on intake and/or discharge end worn	Replace poly seals

**Complete Torque Chart - Capscrews - Grade 5**

**IMPORTANT**

- Grade 5 capscrews can be identified by three radial dashes on head.
- Tighten U-bolts evenly and equally to have the same number of threads exposed on each end.

SIZE	FOOT POUNDS	NEWTON METERS	SIZE	FOOT POUNDS	NEWTON METERS
1/4-20	8-10	11-13	3/4-10	200-220	270-300
1/4-28	9-11	12-15	3/4-16	210-230	285-310
5/16-18	15-17	20-23	7/8-9	330-350	425-475
5/16-24	17-19	23-26	7/8-14	360-380	460-515
3/8-16	25-28	34-38	1-8	500-525	675-710
3/8-24	28-31	38-42	1-14	540-560	730-760
7/16-14	40-45	54-61	1 1/8-7	600-635	815-860
7/16-20	45-50	61-68	1 1/8-12	665-700	920-950
1/2-13	62-68	84-92	1 1/4-7	850-895	1150-1215
1/2-20	68-75	92-102	1 1/4-12	940-990	1275-1340
9/16-12	90-98	22-133	1 3/8-6	1125-1175	1525-1590
9/16-18	100-110	134-148	1 3/8-12	1280-1335	1735-1810
5/8-11	120-135	162-183	1 1/2-6	1500-1560	2035-2115
5/8-18	124-137	168-186	1 1/2-12	1685-1755	2285-2380

**Hydraulic Fittings - Torque and Installation**

**SAE FLARE CONNECTION (J.I.C.)**

1. Tighten nut with finger until it bottoms the seat.
2. Using a wrench, rotate nut to tighten. Turn nut 1/3 turn to apply proper torque.

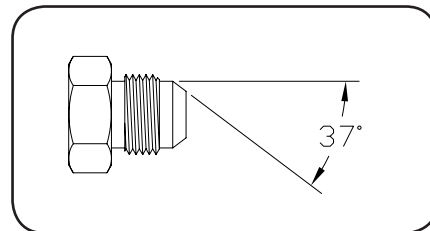

**SAE STRAIGHT THREAD O-RING SEAL**

1. Insure jam nut and washer are backed up to the back side of smooth portion of elbow adapter.
2. Lubricate o-ring -- VERY IMPORTANT!
3. Thread into port until washer bottoms onto spot face.
4. Position elbows by backing up adapter.
5. Tighten jam nut.

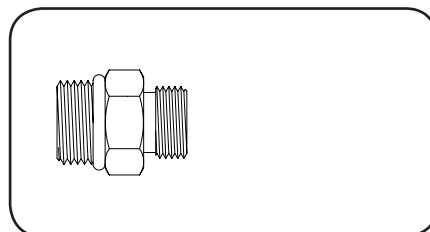

# **SECTION V**

## **Parts**

Idler End Components .....	5-2
Hopper Components .....	5-4
Mounting Brackets & Pivot Cart/Slide Rail Components	
Pivot Car/Slide Rail Components .....	5-6
Extension, Horizontal, & Vertical Post For JD 1770/1775 & DB 30" Row Spacing Planter.....	5-8
Extension, Horizontal, & Vertical Post For JD 1770/1775 & DB 15" Row Spacing Planters.....	5-9
Discharge Spout Components .....	5-12
Telescopic Spout Components.....	5-12
Hydraulic Components .....	5-14
Optional Flow Control Valve Kit Components .....	5-15
Ladder Bundle .....	5-16
Conveyor Options .....	5-17

Idler End Components

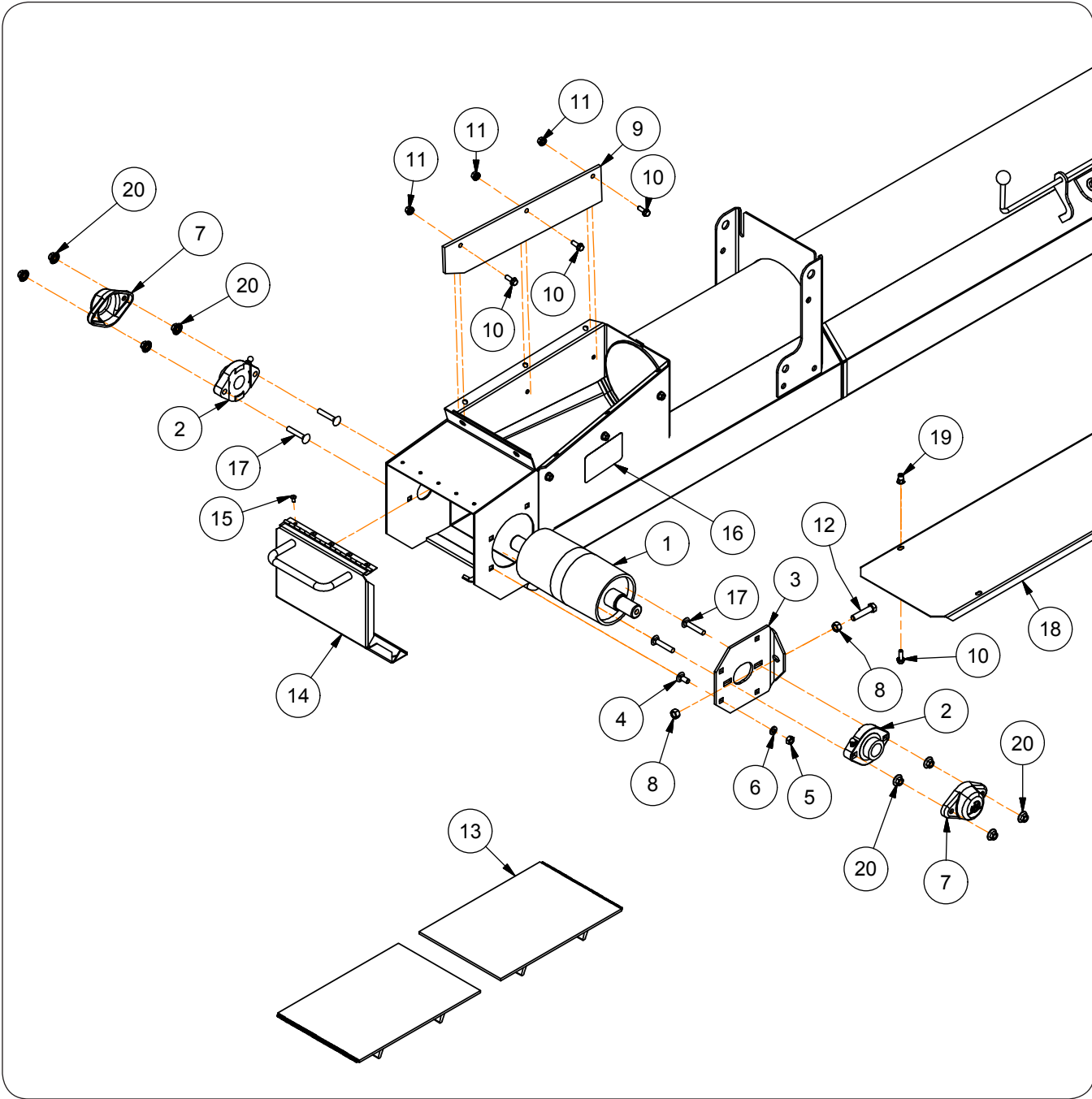

## PLANTER TUBE-CONVEYOR — Parts

### Idler End Components

ITEM	PART NO.	DESCRIPTION	QTY	NOTES
1	900608	Idler Pulley	1	
2	TA0-903088-0	Bearing w/Zerk	4	
3	23912B	Adjustment Plate	1	
4	9388-024	Carriage Bolt, 5/16-18UNC x 3/4	4	Grade 5
5	9394-004	Hex Nut, 5/16-18	16	Grade 5
6	9404-019	Lock Washer, 5/16	20	
7	9500310	Idler Cover	3	
8	9394-006	Hex Nut, 3/8-16UNC	10	Grade 5
9	24756	Poly Strip	2	
10	97420	Flange Screw, 1/4-20UNC x 3/4	20	Grade 5
11	97189	Hex Nut/Large Flange, 1/4-20UNC	20	
12	TA0-907104-0	Capscrew, 3/8"-16UNC x 1 3/4 (Full Threaded)	1	Grade 5
13	900779	Conveyor Belt 8" x 37'-1"	1	
	9501506	Splice Kit	-	
14	23923B	Cleanout Door Weldment	1	
15	TA0-908335-0	Rivet, 3/16 x 3/8	5	
16	TA1-906109-0	Decal, "Warning (Moving Parts)"	2	
17	9388-027	Carriage Bolt, 5/16-18UNC x 1 1/2	8	Grade 5
18	27165B	Bottom Shield	1	
19	902340	Rivet Nut 1/4-20UNC	8	
20	91257	Flange Nut 5/16-18UNC	24	

# PLANTER TUBE-CONVEYOR — Parts

## Hopper Components

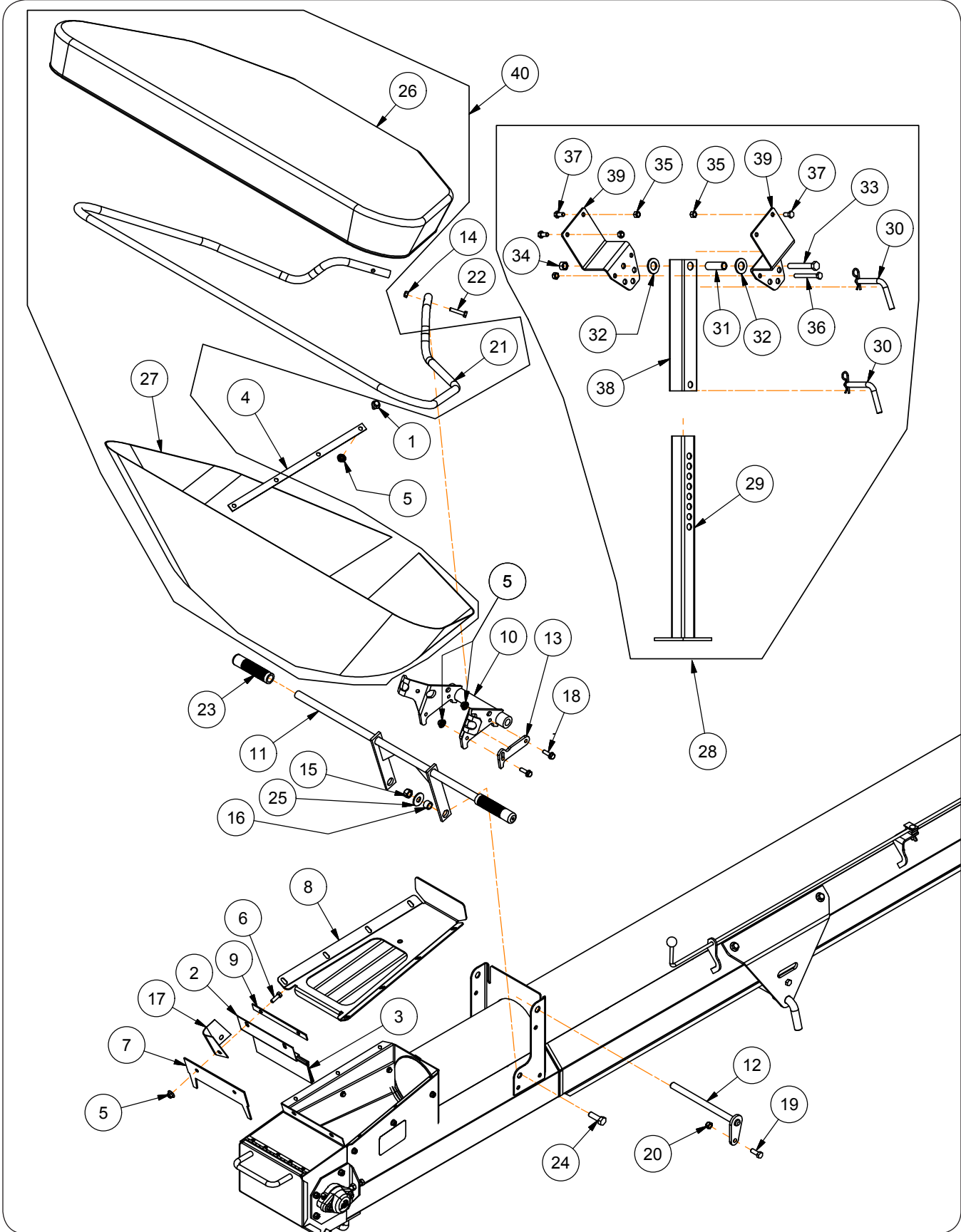

# PLANTER TUBE-CONVEYOR — Parts

## Hopper Components

ITEM	PART NO.	DESCRIPTION	QTY	NOTES
1	91256	Screw/Large Flange, 5/16-18UNC x 3/4	12	GRADE 5
2	24964	Brush Holder	1	
3	901111	Nylon Brush	1	
4	24620B	Strap 3/4 x 17 1/2	2	
5	91257	Hex Nut/ Large Flange, 5/16-18UNC	14	GRADE 5
6	9090-030	Capscrew, 5/16-18UNC x 1	2	GRADE 5
7	26865	Seal	1	
8	28400B	Guard	1	
9	28486B	Strap 3/4 x 7 1/2	1	
10	24554B	Pivot Weldment	1	
11	24576B	Handle Weldment	1	
12	24578	Pin Weldment	1	
13	25434B	Shim Plate	2	
14	9807	Locknut, 5/16-18UNC	2	
15	9800	Locknut, 1/2-13UNC	2	
16	24550	Bushing	2	
17	24986	Poly Strip	2	
18	901044	Screw/Small Flange, 5/16-18UNC x 1	4	GRADE 5
19	9390-055	Capscrew, 3/8"-16UNC x 1	6	GRADE 5
20	9928	Locknut, 3/8-16UNC	3	
21	26918B	Upper Hopper Frame Tube	1	S/N A53950100 & Up
	24549B	Upper Hopper Frame Tube	1	S/N A53950100 & Below
22	9390-032	Capscrew, 5/16-16UNC x 1 1/2	2	GRADE 5
23	92928	Grip/Handle Bar, 3/4 ID x 4.8	2	
24	9390-101	Capscrew, 1/2-13UNC x 1 1/2	2	GRADE 5
25	9405-088	Flat Washer, 1/2 USS Plt	2	
26	27715	Hopper Cover, Vinyl w/Bungee Cord	1	S/N A53950100 & Up
	901472	Hopper Cover, Vinyl		S/N A53950100 & Below
27	902421	Hopper, Vinyl	1	S/N A53950100 & Up
	901058	Hopper, Vinyl		S/N A53950100 & Below
28	26588B	Hopper Lift Stand Bundle (Optional)	1	Includes Items 29-39
29	26574B	Post Weldment	1	
30	900803	Bent Pin w/Hairpin Cotter	2	
31	26587	Bushing	1	
32	9405-104	Flat Washer, 3/4	2	
33	9390-109	Capscrew, 1/2-13UNC x 3 1/2	1	
34	9800	Locknut, 1/2-13UNC	1	
35	9928	Locknut, 3/8-16UNC	5	
36	9390-064	Capscrew, 3/8"-16UNC x 3 1/4	1	
37	9390-053	Capscrew, 3/8"-16UNC x 3/4	4	
38	26572B	Tube w/Holes	1	
39	26586B	Bracket w/Holes	2	
40	27717B	Hopper Bundle	-	Includes Items 21, 26, 27



# PLANTER TUBE-CONVEYOR — Parts

## Mounting Brackets & Pivot Car/Slide Rail Components

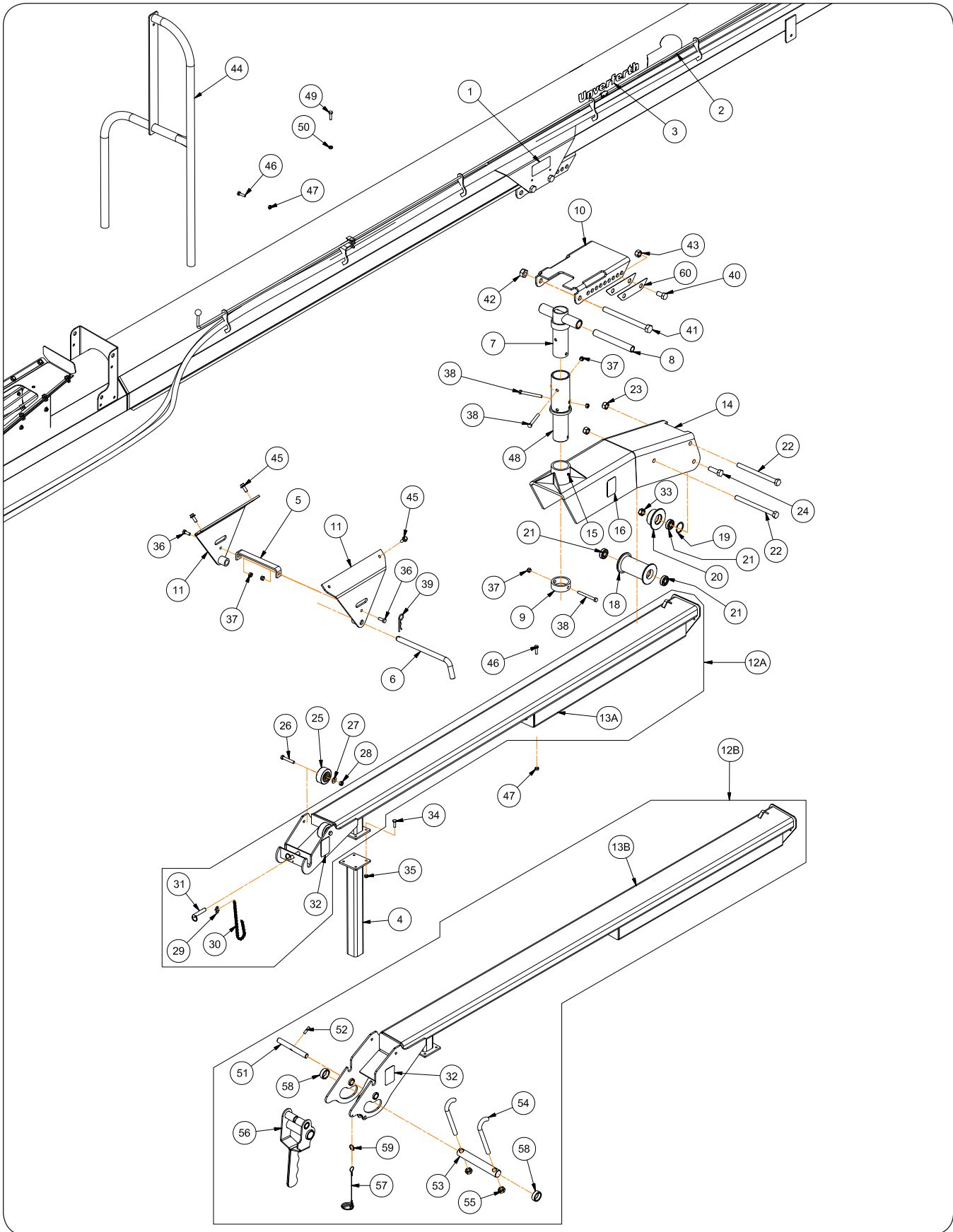

## PLANTER TUBE-CONVEYOR — Parts

### Mounting Brackets & Pivot Car/Slide Rail Components

ITEM	DESCRIPTION	PART NO.
1	Decal, WARNING (Pinch Point)	95839
2	Decal UM Oval	901607
3	Decal UNVERFERTH Logo	901725
4	Post Weldment 14 3/4" Lg.	24413B
5	Bracket/Bent Bar	25156B
6	Bent Pin 3/4" Dia.	25157
7	Pivot Tube Weldment	25160B
8	Tube 7 3/4" Lg.	25307
9	Pivot Collar Weldment	25376B
10	Channel Weldment	26564B
11	Transport Mount Weldment	25155B
12A	Rail Assembly Includes Items: 13A, 14 through 33	26579B
12B	Rail Assembly With Latch Handle Includes Items: 13B, 14 through 28, 32, 33, 51 through 59	2003135B
13A	Slide Rail Weldment	NA
13B	Slide Rail Weldment	2003115B
14	Pivot Car Weldment with Decal	26566B
15	Grease Zerk	91160
16	Decal WARNING (Pinch Point)	97048
17	Roller & Bearing Assembly Includes Items: 18 & 21 NOT SHOWN	27178
18	Roller	24254
19	Retaining Ring	900161
20	Roller Assembly	24247
21	Bearing	95789
22	Capscrew (Grade 5) 5/8-11 x 8" Lg.	9390-140
23	Locknut 5/8-11	9801
24	Capscrew (Grade 5) 5/8-11 x 2" Lg.	9390-124
25	Rubber Wheel with Bearing	99918
26	Capscrew (Grade 5) 3/8"-16UNC x 2 1/4" Lg.	9390-060
27	Flat Washer 3/8" USS	9405-076
28	Locknut 3/8-16	9928
29	S-Hook	98054
30	Sash Chain	23660
31	Hitch Pin 1/2" Dia. x 2 3/4"	99836

ITEM	DESCRIPTION	PART NO.
32	Decal WARNING (Pinch Point)	97048
33	Locknut 5/8-11	95905
34	Capscrew (Grade 5) 5/16-18 x 1" Lg.	9390-030
35	Locknut 5/16-18	9807
36	Capscrew (Grade 5) 3/8"-16UNC x 1	9390-055
37	Locknut 3/8-16	9928
38	Capscrew (Grade 5) 3/8"-16UNC x 3 1/2" Lg.	9390-065
39	Hairpin Cotter 3" Lg.	95959
40	Flange Capscrew (Grade 5) 5/8-11 x 1 1/2" Lg.	9390-122
41	Capscrew (Grade 5) 3/4-10 x 8" Lg.	9390-449
42	Locknut 3/4-10	96732
43	Locknut 5/8-11UNC	9801
44	Hand Rail Weldment	23730G
45	Screw/Large Flange (Grade 5) 3/8"-16UNC x 1	91262
46	Capscrew M8-1.25Px30 For Securing Slide Rail	94917-073
47	Hex Nut M8-1.25P For Securing Slide Rail	97692
48	Refuge Tank Post Kit For Service ONLY Includes Pivot Tube Weldment & Items: 10, 37, 38	26618B
49	Capscrew 1/4-20UNC x 3/4 For Battery Access Door Hinge	9390-003
50	Large Flange Hex Nut 1/4-20UNC For Battery Access Door Hinge	97189
51	Shaft 3/4" Dia. x 6 1/4	2003128
52	Roll Pin 5/16" Dia. x 1 1/4	9392-153
53	Shaft 1 1/4" Dia. x 8 1/2	2003119
54	Draw Hook 5/8" Dia.	2003118
55	Hex Jam Nut 5/8-18UNF	9395-013
56	Latch Handle Weldment	2003123B
57	Lynch/Klik Pin 7/16" Dia.	901170
58	Bushing 1 5/8" Dia.	2003138
59	Split Ring 15/16" Dia.	9501116
60	Shim	2005843B
	Shim Kit	2006141B

# PLANTER TUBE-CONVEYOR — Parts

## Extension, Horizontal, & Vertical Post For JD 1770/1775 & DB 30" Row Spacing Planters

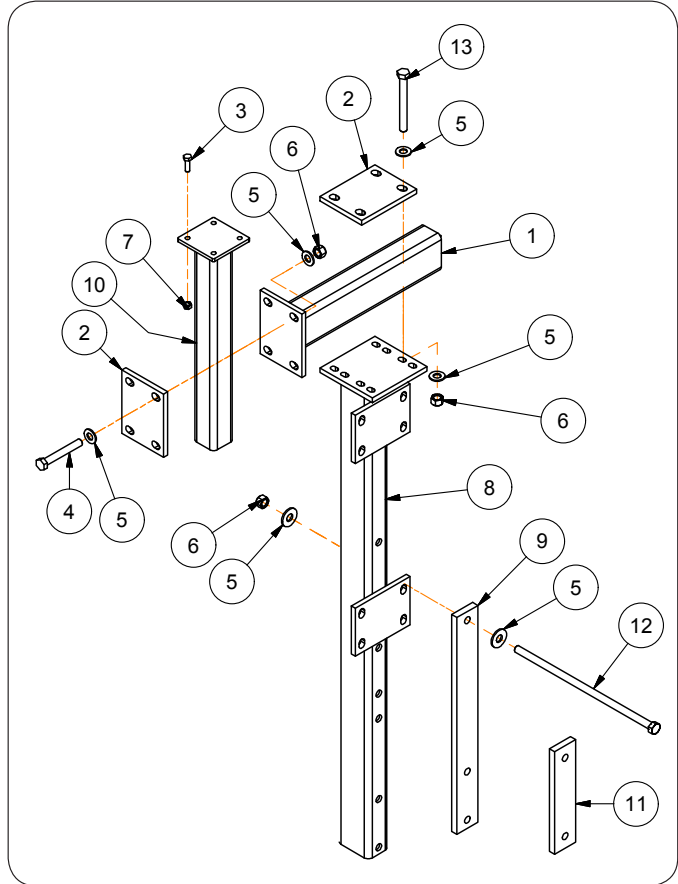
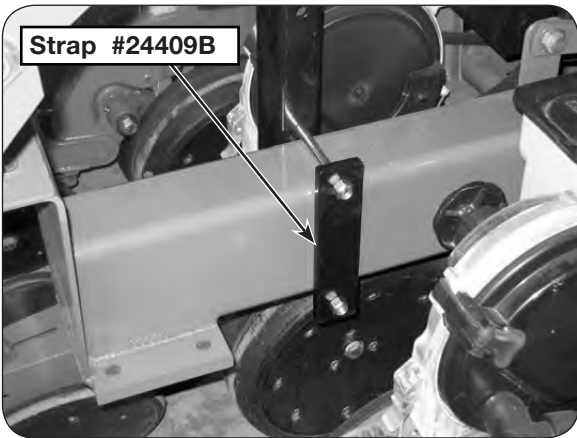

ITEM	PART NO.	DESCRIPTION	QTY	NOTES
1	24340B	Extension Post	1	
2	23751B	Plate 4 x 5 1/4 with Slots	2	
3	9390-030	Capscrew 5/16-18UNC x 1	4	Grade 5
4	9390-109	Capscrew 1/2-13UNC x 3 1/2	4	Grade 5
5	9405-086	Flat Washer 1/2" SAE	20	
6	9800	Locknut 1/2-13UNC	10	
7	9807	Locknut 5/16-18UNC	4	
8	24338B	Vertical Post with Mounting Plates	1	
9	24341B	Strap 2 x 18	1	For JD 1770/1775 CCS Planter
10	24413B	Bolt-On Post Weldment 16 3/4" Long	1	
11	24409B	Strap 2 x 8 1/2	1	For JD DB CCS Planter
12	9390-901012	Capscrew 1/2-13UNC x 13	2	Grade 5
13	9390-112	Capscrew 1/2-13UNC x 4 1/2	4	Grade 5

# PLANTER TUBE-CONVEYOR — Parts

## Extension, Horizontal, & Vertical Post — For JD DB60 24 Row, 15" Spacing Planters (Produced 2016 & After)

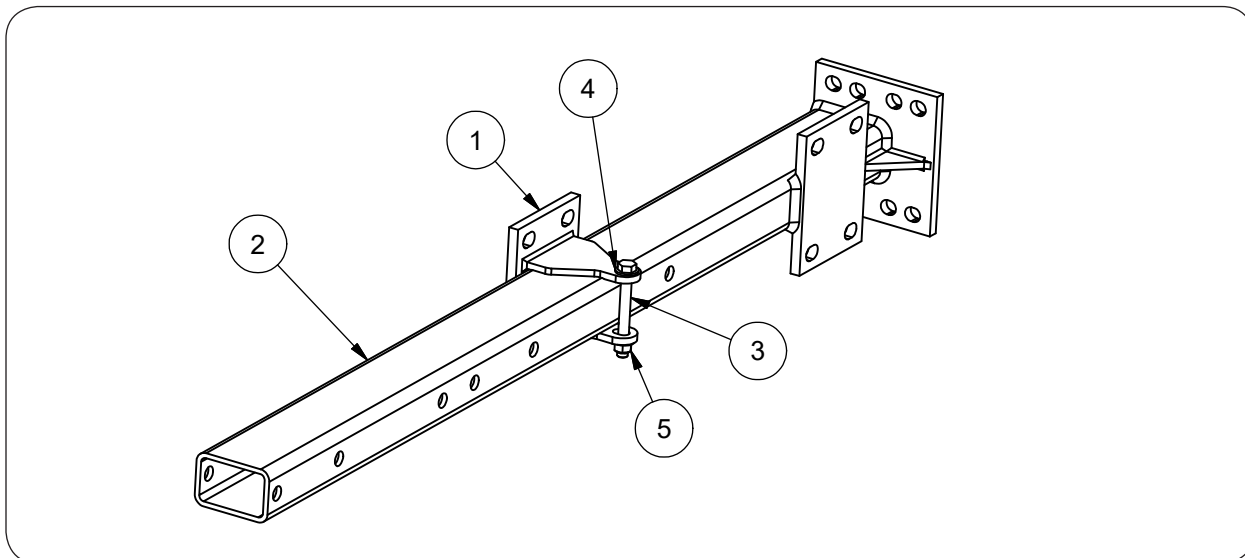

ITEM	PART NO.	DESCRIPTION	QTY	NOTES
	2009303B	Conveyor Mounting Kit For DB60 Planters with 24 Rows; 15" Spacing	-	
1	2008500B	Bracket Weldment	1	
2	2009062B	Vertical Post	1	
3	9390-064	Capscrew, 3/8"-16UNC x 3 1/4" G5	1	
4	9405-074	Flat Washer 3/8" SAE	2	
5	9928	Lock Nut 3/8"-16UNC	1	

# PLANTER TUBE-CONVEYOR — Parts

## Extension, Horizontal, & Vertical Post — For JD 1770/1775 & DB 20/22" Row Spacing Planters (Produced 2016 & After)

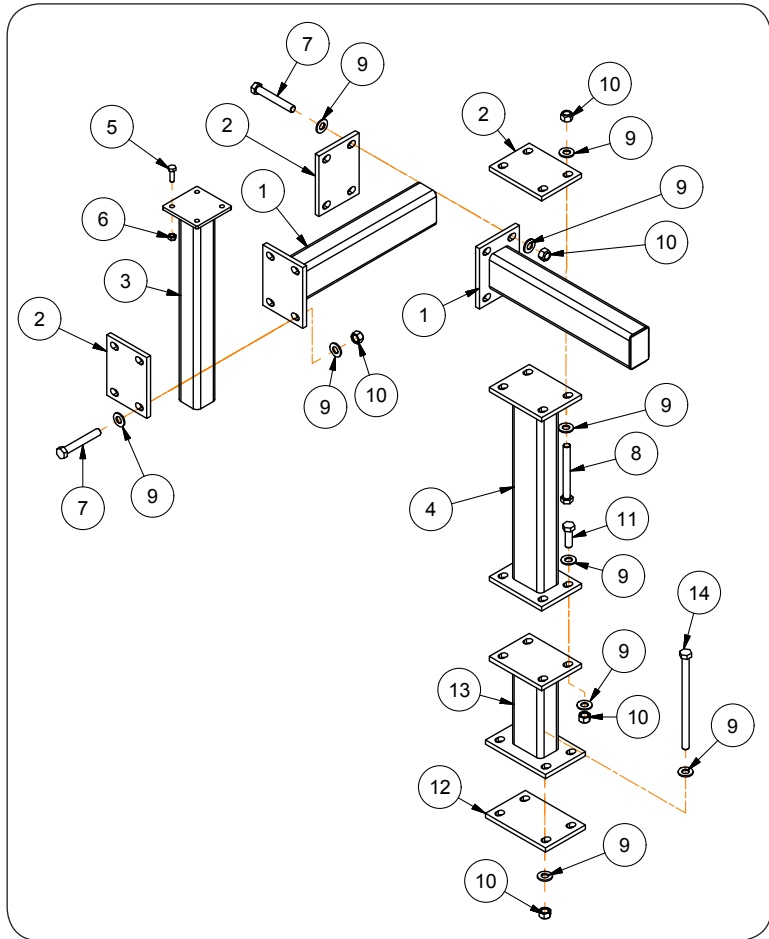
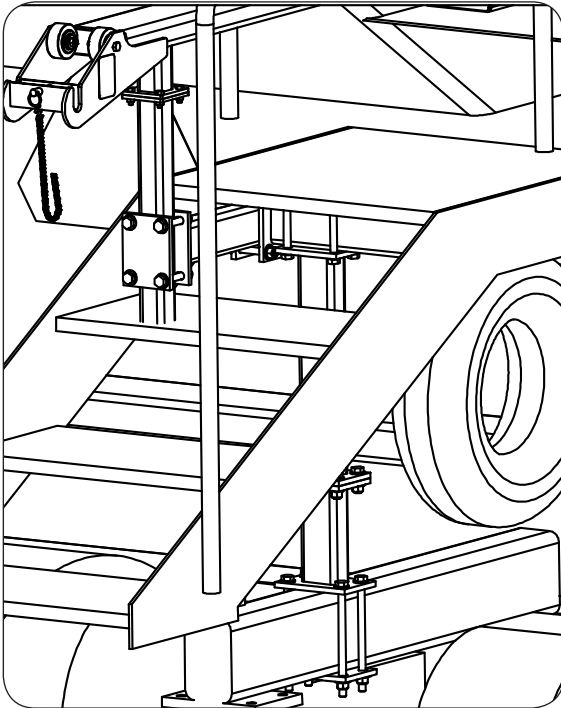

ITEM	PART NO.	DESCRIPTION	QTY	NOTES
	29754B	Conveyor Mounting Kit For DB Planters with 20/22" Rows	-	Includes Items 1, 2, 7, 9, 10, 11, 12, 13, 14
1	24340B	Extension Post	1	
2	23751B	Plate 4 x 5 1/4 with Slots	1	
3	24413B	Bolt-On Post Weldment 16 3/4" Long	1	
4	28442B	Post Weldment	2	
5	9390-030	Capscrew 5/16-18UNC x 1	4	Grade 5
6	9807	Locknut 5/16-18UNC	4	
7	9390-109	Capscrew 1/2-13UNC x 3 1/2	8	Grade 5
8	9390-112	Capscrew 1/2-13UNC x 4 1/2	4	
9	9405-086	Flat Washer 1/2" SAE	24	
10	9800	Locknut 1/2-13UNC	1	
11	9390-101	Capscrew 1/2-13UNC x 1 1/2	4	Grade 5
12	2000016B	Plate 4 x 6 with Slots	1	
13	2000014B	Post Weldment	1	
14	9390-119	Capscrew 1/2-13UNC x 8	4	Grade 5

# PLANTER TUBE-CONVEYOR — Parts

## Extension, Horizontal, & Vertical Post — For JD 1770/1775 & DB 15" Row Spacing Planters (Produced 2016 & After)

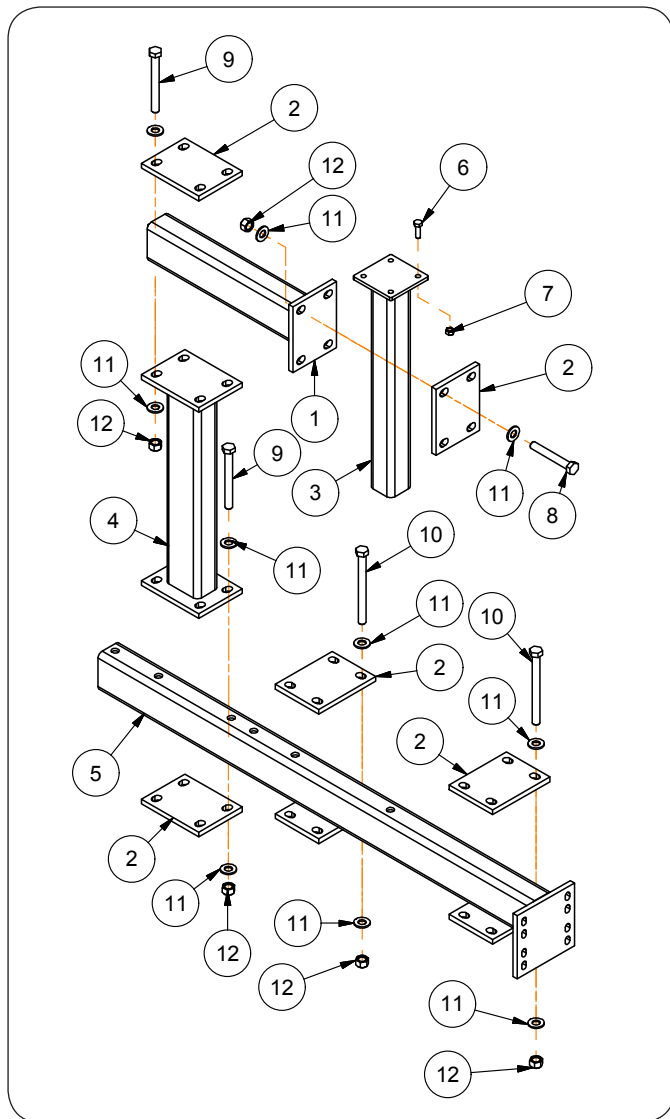
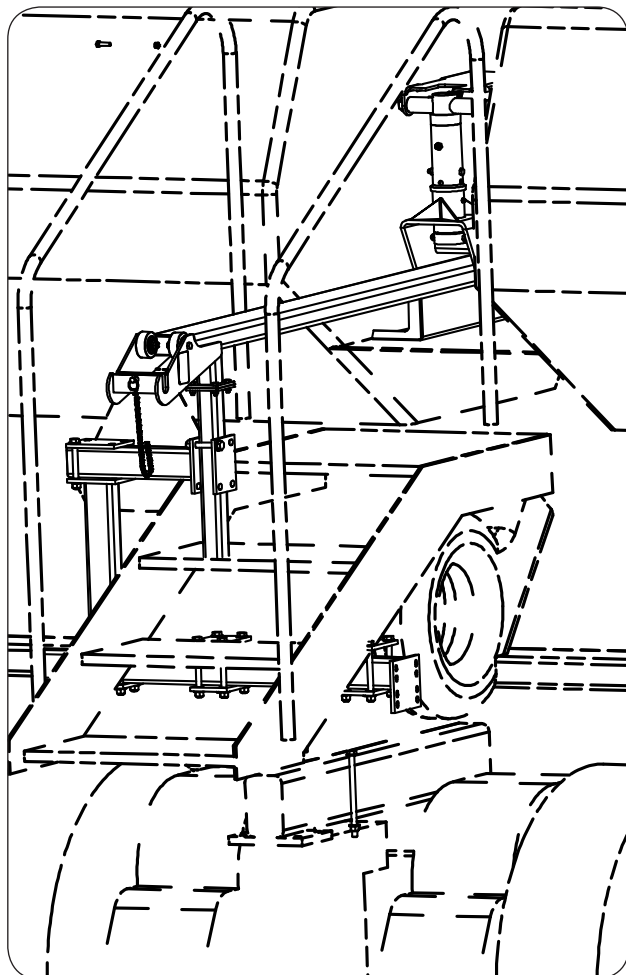

ITEM	PART NO.	DESCRIPTION	QTY	NOTES
1	24340B	Extension Post	3	
2	23751B	Plate	8	
3	24413B	Post Weldment	1	
4	28442B	Post Weldment	2	
5	24338B	Vertical Post	1	
6	9390-030	Capscrew 5/16-18UNC x 1	4	Grade 5
7	9807	Locknut 5/16-18UNC	4	
8	9390-109	Capscrew 1/2-13UNC x 3 1/2	4	Grade 5
9	9390-112	Capscrew 1/2-13UNC x 4 1/2	8	Grade 5
10	9390-114	Capscrew 1/2-13UNC x 5 1/2	8	Grade 5
11	9405-086	Flat Washer 1/2 SAE	40	
12	9800	Locknut 1/2-13UNC	20	

**Discharge Spout Components**

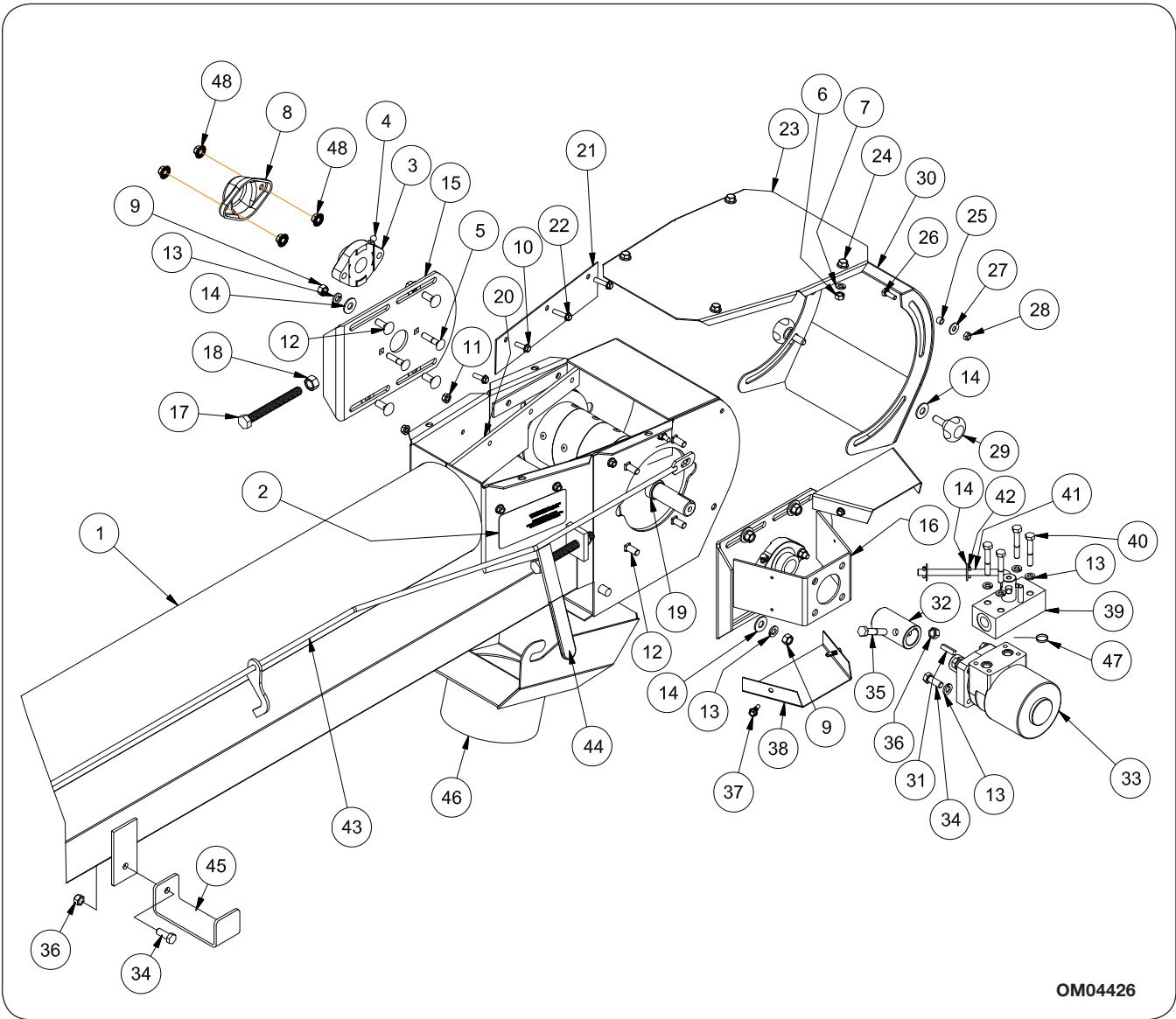

OM04426

**Telescopic Spout Components**

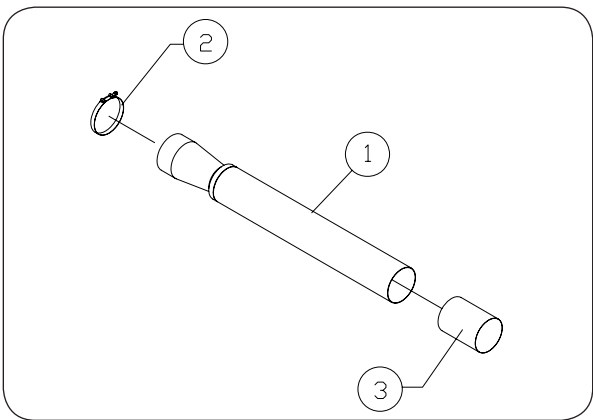

ITEM	PART NO.	DESCRIPTION
1	27629	5' Telescopic Spout w/Sock
	21759	Flexible Hose 6" OD x 18" (For Repairs)
2	98060	Clamp
3	22577	Sock, 5 3/4" Dia. x 8" Lg



# PLANTER TUBE-CONVEYOR — Parts

## Discharge Spout Components

ITEM	PART NO.	DESCRIPTION	QTY	NOTES
1	2005362B	Conveyor Weldment with Decals	1	
2	TA1-906109-0	Decal, "WARNING (Moving Parts)"	2	
3	TA0-903088-0	Bearing w/Zerk	4	
4	93415	Grease Zerk 90°	2	
5	9388-027	Carriage Bolt, 5/16-18UNC x 1 1/2 (Gr. 5)	8	
6	9394-004	Hex Nut, 5/16-18UNC (Gr. 5)	16	
7	9404-019	Lock Washer, 5/16	16	
8	9500310	Idler Cover	3	
9	9394-006	Hex Nut, 3/8"-16UNC (Gr. 5)	10	
10	97420	Flange Screw, 1/4-20UNC x 3/4 (Gr. 5)	14	
11	97189	Large Flange Hex Nut, 1/4-20UNC (Gr. 5)	18	
12	9388-051	Carriage Bolt, 3/8"-16UNC x 1 (Gr. 5)	8	
13	9404-021	Lock Washer, 3/8	16	
14	9405-076	Flat Washer, 3/8 USS PLT	12	
15	23994B	Adjustment Plate	1	
16	24091B	Bracket Weldment	1	
17	93400	Capscrew, 1/2-13UNC x 4 1/2 (Gr. 5)	2	
18	9394-010	Hex Nut, 1/2-12UNC (Gr. 5)	2	
19	901077	Drive Pulley	1	
20	24755	Poly Strip	2	
21	24260	Seal	2	
22	901101	Flange Screw, 1/4-20UNC x 1 (Gr. 5)	4	
23	23918B	Top Shield	1	
24	91256	Large Flange Screw, 5/16-18UNC x 3/4	14	
25	22018	Bushing	2	
26	9390-003	Capscrew, 1/4-20UNC x 3/4 (Gr. 5)	3	
27	9405-064	Flat Washer, 1/4 USS	4	
28	9936	Locknut, 1/4-20UNC	19	
29	901046	Knob	2	
30	26214B	Deflector Weldment	1	
	901723	Neoprene Sheet	1	
	902006	Elevator Bolt 1/4"-20UNC x 3/4"	4	
	97189	Hex Nut/Large Flange 1/4"-20UNC	4	
31	9001501	Keystock, 1/4 x 1/4 x 1	1	
32	23690	Coupler	1	
33	91604B	Hydraulic Motor	1	
34	9390-055	Capscrew, 3/8"-16UNC x 1 (Gr. 5)	6	
35	9390-059	Capscrew, 3/8"-16UNC x 2 (Gr. 5)	1	
36	9928	Locknut, 3/8-16UNC	3	
37	9473	Self-Drilling Screw, 1/4-20UNC x 3/4	4	
38	24399B	Shield	2	
39	95488	Hydraulic Valve Control	1	
40	9390-034	Capscrew, 5/16-18UNC x 2 (Gr. 5)	4	
41	23693	Handle, 3/8" Dia.	1	
42	9392-056	Roll Pin, 1/8D x 3/4	2	
43	24077	Control Rod Weldment	1	
44	900209	Cap/Vinyl Handle	1	
45	24414B	Bracket	1	
46	26673B	Spout Weldment	1	
47	91306	O-Rings	2	
48	91257	Flange Nut 5/16-18UNC	24	



# PLANTER TUBE-CONVEYOR — Parts

## Hydraulic Components

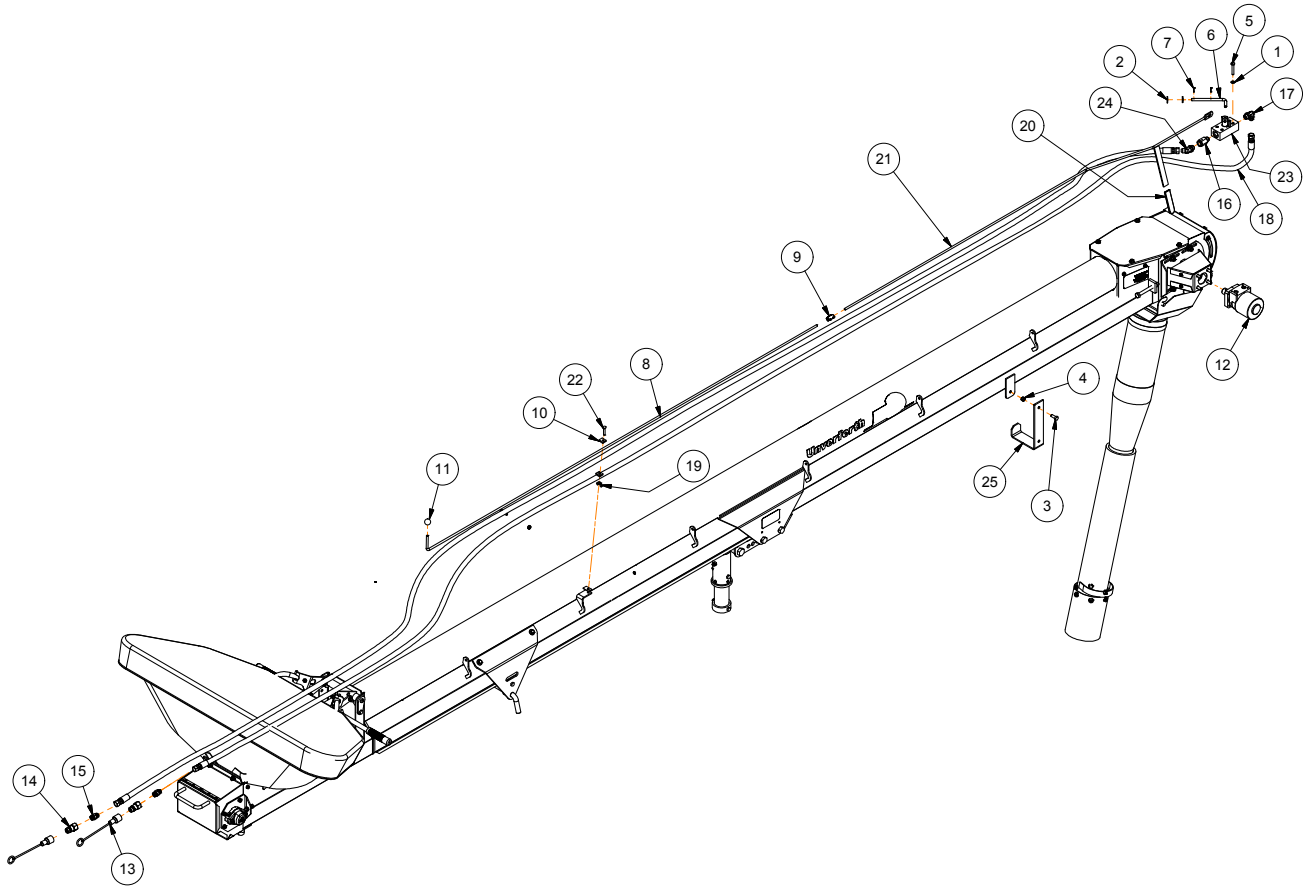

ITEM	PART NO.	DESCRIPTION
1	9404-019	Lock Washer, 5/16"
2	9405-076	Flat Washer 3/8 USS
3	9390-055	Capscrew (Grade 5) 3/8"-16UNC x 1
4	9928	Locknut 3/8-16UNC
5	9390-034	Capscrew (Grade 5) 5/16-18UNC x 2"
6	23693	Handle
7	9392-056	Roll Pin 1/8" Dia. x 3/4"
8	23698	Control Rod 92 3/16" Long
9	23701	Coupler 1 1/4" Long
10	24266	Friction Block
11	TA0-914793-0	Knob 1" Dia. Plastic, 5/16-18 Threaded
12	91604B	Hydraulic Motor 6 CU. IN.
	91687	Seal Kit for Hyd Motor
13	91511	Dust Cap

ITEM	PART NO.	DESCRIPTION
14	91383	Coupling 3/4-16 O-Ring Female
15	9864	Adapter 3/4-16 JIC Male x 3/4-16 O-Ring Male
16	94909	In-Line Check Valve with 3/4-16 O-Ring Ports
17	9863	Elbow 90°
18	23851	Hose 1/2 x 240" Long
19	901056	Wing Nut Nylon 1/4-20UNC
20	900209	Vinyl Handle
21	24077	Control Rod Weldment (Includes Item 20)
22	9388-005	Carriage Bolt (Grade 5) 1/4-20UNC x 1 1/2
23	95488	Hyd Control Valve with 3/4-16 Ports
	96918	Seal Kit for Hyd Control Valve
24	93586	Elbow 45°
25	24414B	Telescopic Spout Bracket

**Flow Control Valve Kit Components**

**OPEN CENTER SYSTEM**

OM23886

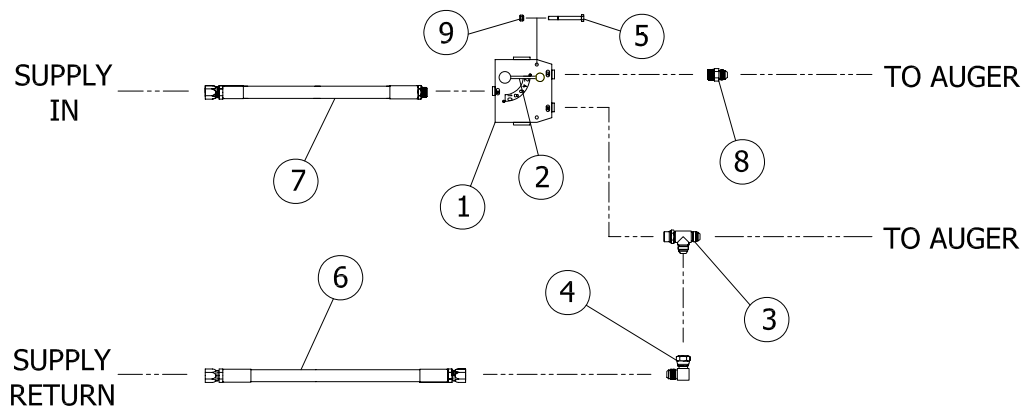

**CLOSED CENTER SYSTEM**

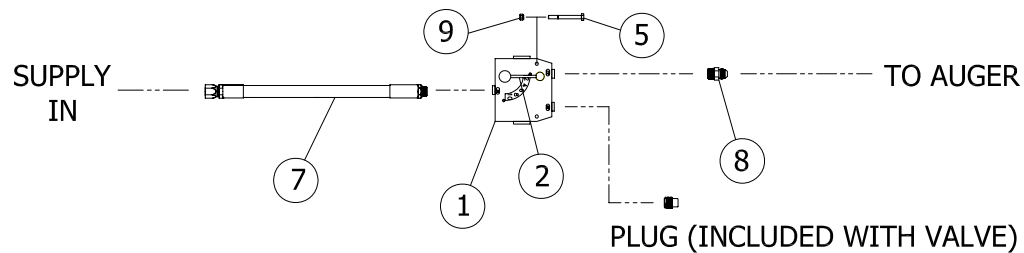

ITEM	PART NO.	DESCRIPTION
	23669	Flow-Control Valve Kit For Open-Center Systems & Closed-Center Systems
1	9000832	Flow Control Valve Less Handle
2	900241	Handle
3	93588	Tee
4	93683	Elbow 90°
5	9390-011	Capscrew 1/4-20 x 2 1/2" Lg.
6	95144	Hose 1/2 x 20" Lg.
7	97742	Hose 1/2 x 18" Lg.
8	9864	Adapter
9	9936	Locknut 1/4-20

**Ladder Bundle**

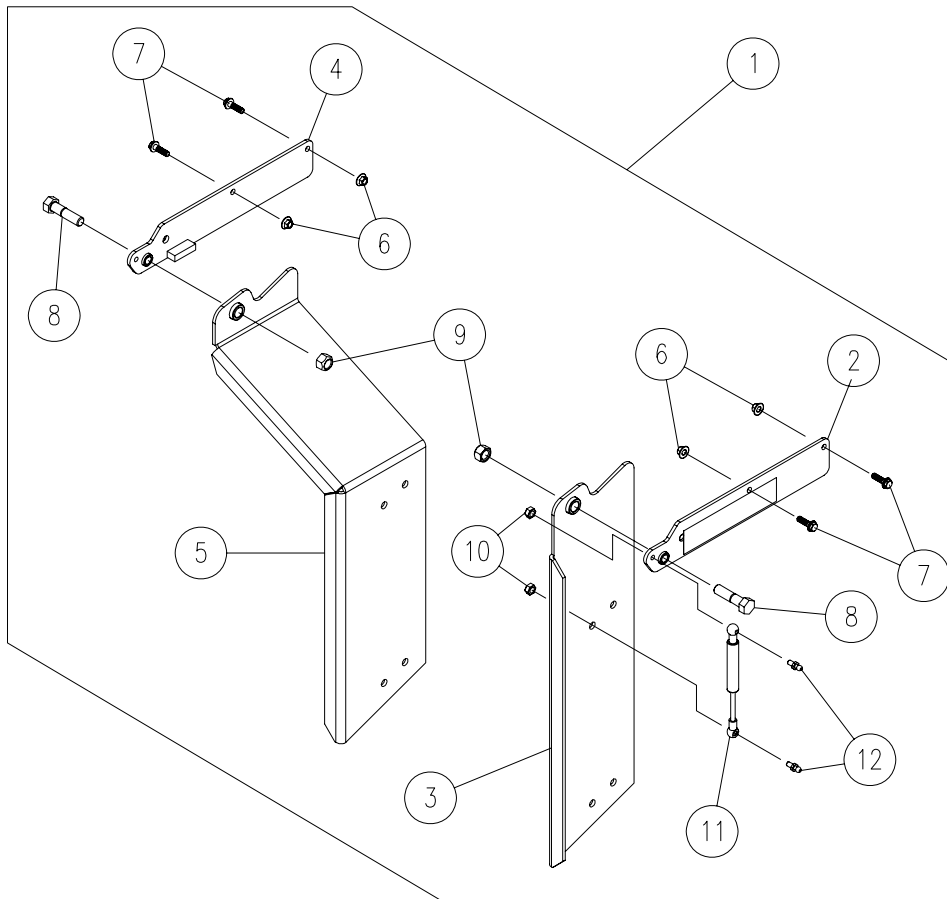

ITEM	PART NO.	DESCRIPTION	QTY
1	24516	Ladder Bundle	-
2	24344G	Plate Assembly LH w/Reflector	1
	9003127	Reflector =Amber=	-
3	24346G	Ladder Side Rail Weldment	1
4	24348G	Plate Assembly RH w/Reflector	1
	9003127	Reflector =Amber=	-
5	24350G	Side Rail	1
6	91263	Nut/Large Flange, 3/8-16UNC	4
7	9003259	Capscrew/Flange, 3/8"-16UNC x 1 1/4	4
8	9390-103	Capscrew, 1/2-13UNC x 2	2
9	9800	Locknut, 1/2-13UNC	2
10	9807	Locknut, 5/16-18UNC	2
11	98086	Gas Spring Assembly w/Clevis	1
12	98088	Ball Stud, 5/16-18UNC Threaded End	2

**Conveyor Options**

**Belt Stretcher**  
(Part No. TA4-114400-0)

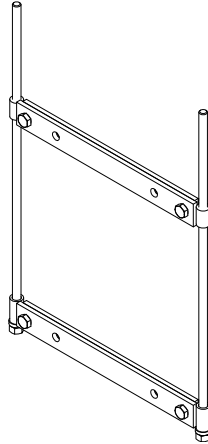



***Unverferth***<sup>®</sup>  
***Manufacturing Company, Inc.***

[www.unverferth.com](http://www.unverferth.com)